

MEMS motion sensor: two-axis digital output gyroscope for optical image stabilization

Datasheet - production data

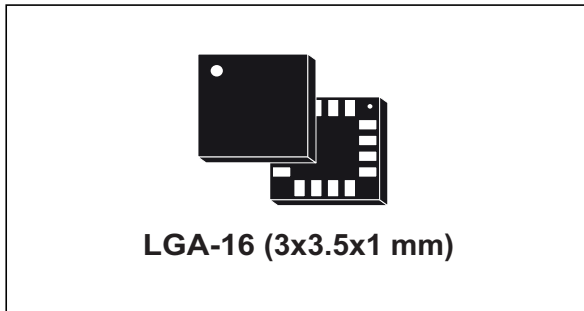

Description

The L2G3IS is a two-axis MEMS gyroscope for optical image stabilization applications.

It includes a sensing element and an IC interface capable of providing the measured angular rate to the external world through an SPI digital interface.

The unique sensing element is manufactured using a dedicated micromachining process developed by STMicroelectronics to produce inertial sensors and actuators on silicon wafers.

The IC interface is manufactured using a CMOS process that allows a high level of integration to design a dedicated circuit which is trimmed to better match the sensing element characteristics.

The L2G3IS is available in a plastic land grid array (LGA) package and can operate over a temperature range of -40 °C to +85 °C.

Features

- ± 65 dps / ± 130 dps full-scale range
- SPI digital interface
- Embedded temperature sensor
- Integrated low- and high-pass filters with user-selectable bandwidth
- Wide supply voltage range: 2.4 V to 3.6 V
- Low-voltage compatible IOs (1.8 V)
- Power-down and sleep modes for smart power saving
- ECOPACK[®], RoHS and “Green” compliant

Applications

- Optical image stabilization

Table 1. Device summary

Order code	Temperature range (°C)	Package	Packing
L2G3IS	-40 to +85	LGA-16 (3x3.5x1)	Tray
L2G3ISTR	-40 to +85	LGA-16 (3x3.5x1)	Tape and reel

Contents

1	Block diagrams and pin description	6
1.1	Digital block diagram	6
1.2	Pin description	7
2	Terminology & functionality	8
2.1	Sensitivity	8
2.2	Zero-rate level	8
2.3	Synchronous reading	8
2.4	Temperature sensor	8
3	Mechanical and electrical characteristics	9
3.1	Mechanical characteristics	9
3.2	Electrical characteristics	10
3.3	Temperature sensor characteristics	11
3.4	SPI - serial peripheral interface	12
3.5	Absolute maximum ratings	13
4	Application hints	14
5	Digital interfaces	15
5.1	SPI bus interface	15
5.1.1	SPI write	15
5.1.2	SPI read	16
6	Output register mapping	17
7	Register description	18
7.1	OUT_X_L (03h), OUT_X_H (04h)	18
7.2	OUT_Y_L (05h), OUT_Y_H (06h)	18
7.3	STATUS_REG (09h)	18
7.4	CTRL_REG1 (0Bh)	18
7.5	CTRL_REG2 (0Ch)	19
7.6	CTRL_REG3 (0Dh)	19

7.7	ORIENT_CONFIG (10h)	20
7.8	CTRL_REG4 (15h)	20
7.9	CTRL_REG5 (1Fh)	21
7.10	CTRL_TEMP (20h)	22
7.11	OUT_TEMP (26h)	22
8	Soldering information	23
9	Package information	24
10	Revision history	25

List of tables

Table 1.	Device summary	1
Table 2.	Pin description	7
Table 3.	Mechanical characteristics	9
Table 4.	Electrical characteristics	10
Table 5.	Temperature sensor characteristics	11
Table 6.	SPI slave timing values	12
Table 7.	External components	14
Table 8.	Serial interface pin description	15
Table 9.	Register address map	17
Table 10.	STATUS_REG register	18
Table 11.	STATUS_REG description	18
Table 12.	CTRL_REG1 register	18
Table 14.	Operating mode selection	19
Table 13.	CTRL_REG1 description	19
Table 15.	CTRL_REG2 register	19
Table 16.	CTRL_REG2 description	19
Table 17.	CTRL_REG3 register	19
Table 19.	Low-pass filter cutoff frequency	20
Table 18.	CTRL_REG3 description	20
Table 20.	ORIENT_CONFIG register	20
Table 21.	ORIENT_CONFIG description	20
Table 22.	Directional orientation selection	20
Table 23.	CTRL_REG4 register	20
Table 24.	CTRL_REG4 description	21
Table 25.	CTRL_REG5 register	21
Table 26.	CTRL_REG5 description	21
Table 27.	High-pass filter cutoff frequency selection	21
Table 28.	CTRL_TEMP register	22
Table 29.	CTRL_TEMP description	22
Table 30.	OUT_TEMP register	22
Table 31.	OUT_TEMP description	22
Table 32.	Document revision history	25

List of figures

Figure 1.	Block diagram	6
Figure 2.	Digital block diagram	6
Figure 3.	Pin connections	7
Figure 4.	SPI slave timing diagram	12
Figure 5.	L2G3IS electrical connections and external component values	14
Figure 6.	SPI write protocol	15
Figure 7.	Multiple byte SPI write protocol (2-byte example).	16
Figure 8.	SPI read protocol	16
Figure 9.	LGA-16: mechanical data and package dimensions.	24

1 Block diagrams and pin description

Figure 1. Block diagram

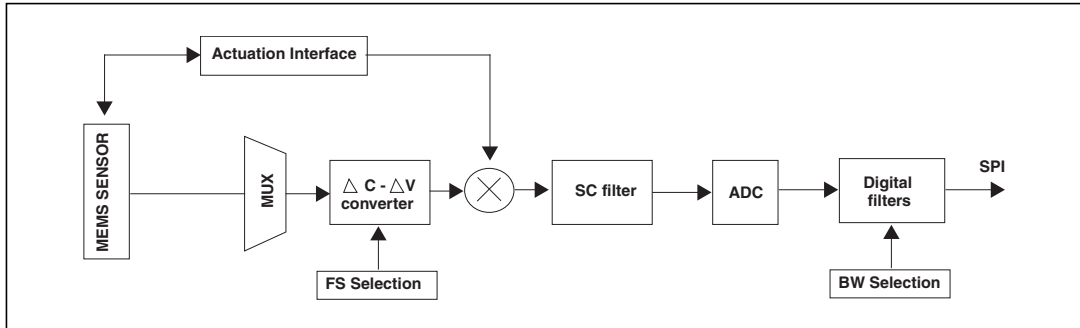

1.1 Digital block diagram

Figure 2. Digital block diagram

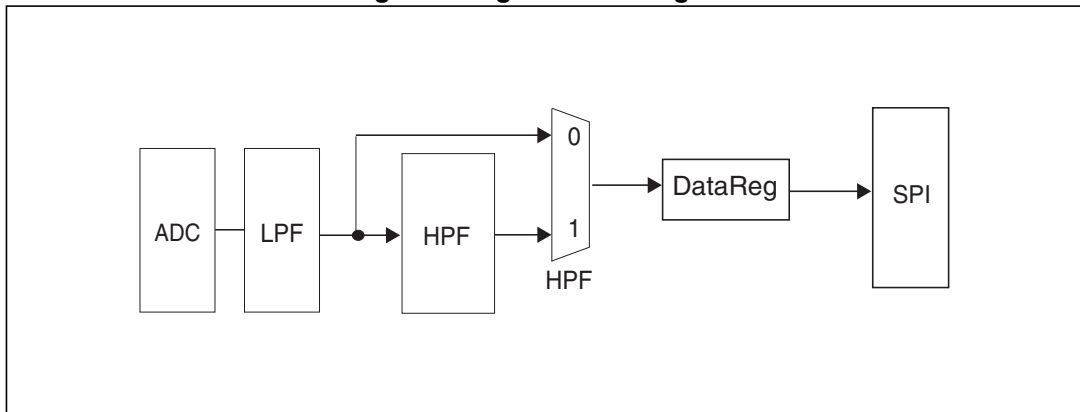

1.2 Pin description

Figure 3. Pin connections

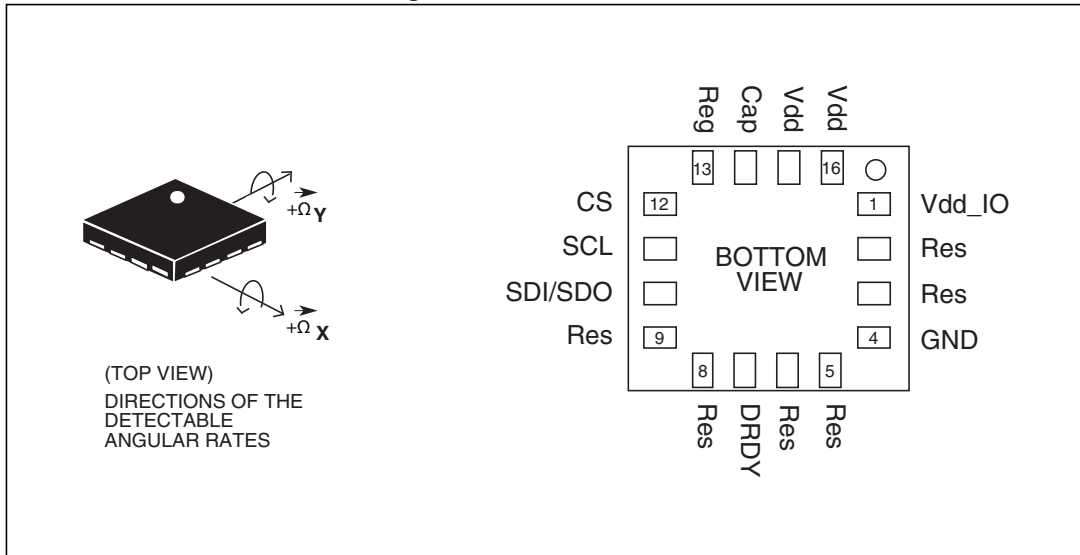

Table 2. Pin description

Pin#	Name	Function
1	Vdd_IO	Power supply for I/O pins
2	Res	Connect to GND
3	Res	Connect to GND
4	GND	0 V power supply
5	Res	Leave unconnected
6	Res	Connect to GND
7	DRDY	Data ready signal (open-drain pad)
8	Res	Leave unconnected
9	Res	Leave unconnected
10	SDI/SDO	Data-in, data-out line
11	SCL	Clock line for SPI interface
12	CS	SPI chip-select line
13	Reg	Capacitance connection pin for internal regulator
14	Cap	Capacitance connection pin for internal charge pump
15	Vdd	Power supply
16	Vdd	Power supply

2 Terminology & functionality

2.1 Sensitivity

An angular rate gyroscope is a device that produces a positive-going digital output for counterclockwise rotation around the sensitive axis considered. Sensitivity describes the gain of the sensor and can be determined by applying a defined angular velocity to it. This value changes very little over temperature and time.

2.2 Zero-rate level

The zero-rate level describes the actual output signal if there is no angular rate present. The zero-rate level of highly accurate MEMS sensors is, to some extent, a result of stress to the sensor and therefore the zero-rate level can slightly change after mounting the sensor on a printed circuit board or after exposing it to extensive mechanical stress. This value changes very little over temperature and time.

2.3 Synchronous reading

On the L2G3IS the angular rate data can be retrieved using a synchronous read. This functionality is recommended to improve the sensor performance.

To perform a synchronous read when using the SPI interface, the REG_EN bit in [CTRL_REG1 \(0Bh\)](#) has to be set to '1'. Then the DRDY_EN bit in [CTRL_REG4 \(15h\)](#) has to be set to '1' in order to enable the data ready interrupt on the DRDY pin (refer to [Figure 5](#)).

To properly perform a synchronous read, the angular rate data have to be read every time the DRDY pin goes low.

2.4 Temperature sensor

To retrieve the temperature data, the gyroscope has to be in sleep mode (PW<1:0> bit in [CTRL_REG1 \(0Bh\)](#) set to '10'), the REG_EN bit in [CTRL_REG1 \(0Bh\)](#) has to be set to '1' and the temperature sensor can be enabled by setting the TEMP_EN bit to '1' in [CTRL_TEMP \(20h\)](#).

The temperature data can be retrieved from the [OUT_TEMP \(26h\)](#) register, as two's complement data in 8-bit format left-justified. The output of the temperature sensor is 0 at 25 °C.

Once the temperature data have been acquired, the temperature sensor has to be turned off to restart the acquisition of the angular rate data. The TEMP_EN bit in [CTRL_TEMP \(20h\)](#) has to be set to '0' and the gyroscope operative mode has to be changed to normal mode (PW<1:0> bit in [CTRL_REG1 \(0Bh\)](#) set to '11').

3 Mechanical and electrical characteristics

3.1 Mechanical characteristics

V_{dd} = 3.3 V and T = 25 °C unless otherwise noted^(a).

Table 3. Mechanical characteristics

Symbol	Parameter	Test condition	Min.	Typ. ⁽¹⁾	Max.	Unit
FS	Measurement range		±65			dps
			±130			
So	Sensitivity	FS = ±65 dps		225		LSb/dps
		FS = ±130 dps		112.5		
SoDr	Sensitivity change vs. temperature	From -40 °C to +85 °C		±3		%
DVoff	Digital zero-rate level			±5		dps
OffDr	Zero-rate level change vs. temperature	From -40 °C to +85 °C		±9		dps
NL	Non-linearity ⁽²⁾	Best-fit straight line		±0.1		% FS
Rn	Rate noise density ⁽²⁾	0 - 20 Hz bandwidth		0.006		dps/(√Hz)
BW	Internal bandwidth	LPF set to '1'		370		Hz
PhDI	Phase delay	At 20 Hz (370 Hz BW selected)		4.5		deg
ODR	Digital output data rate			9.5		kHz
Top	Operating temperature range		-40		+85	°C

1. Typical specifications are not guaranteed.
2. Guaranteed by design.

a. The product is factory calibrated at 3.3 V. The operational power supply range is specified in [Table 4](#).

3.2 Electrical characteristics

@ Vdd = 3.3 V, T = 25 °C unless otherwise noted^(b).

Table 4. Electrical characteristics

Symbol	Parameter	Test condition	Min.	Typ. ⁽¹⁾	Max.	Unit
Vdd	Supply voltage		2.42	3.3	3.6	V
Vdd_IO	I/O pins supply voltage ⁽²⁾		1.71		Vdd+0.1	V
Idd	Supply current in normal mode			6.4		mA
IddSL	Supply current in sleep mode ⁽³⁾			2.5		mA
IddPdn	Supply current in power-down mode			20		µA
VIH	Digital high-level input voltage		0.8*Vdd_IO			V
VIL	Digital low-level input voltage				0.2*Vdd_IO	V
Top	Operating temperature range		-40		+85	°C

1. Typical specifications are not guaranteed.
2. It is possible to remove Vdd maintaining Vdd_IO without blocking the communication busses, in this condition the measurement chain is powered off.
3. Sleep mode introduces a faster turn-on time relative to power-down mode.

b. The product is factory calibrated at 3.3 V.

3.3 Temperature sensor characteristics

@ AVdd = 3.3 V, T = 25 °C unless otherwise noted^(c).

Table 5. Temperature sensor characteristics

Symbol	Parameter	Test condition	Min.	Typ. ⁽¹⁾	Max.	Unit
TSDr	Temperature sensor output change vs. temperature			1		°C/digit
TODR	Temperature refresh rate			1		Hz
TACC	Temperature absolute accuracy ⁽²⁾			±4		°C
Top	Operating temperature range		-40		+85	°C

1. Typical specifications are not guaranteed.
2. The output of the temperature sensor is 0 at 25 °C. Refer to [Section 2.4: Temperature sensor](#) on how to enable and read the temperature sensor output data.

c. The product is factory calibrated at 3.3 V.

3.4 SPI - serial peripheral interface

Subject to general operating conditions for Vdd and Top.

Table 6. SPI slave timing values

Symbol	Parameter	Value ⁽¹⁾		Unit
		Min	Max	
$t_{c(SPC)}$	SPI clock cycle	100		ns
$f_{c(SPC)}$	SPI clock frequency		10	MHz
$t_{su(CS)}$	CS setup time	5		ns
$t_{h(CS)}$	CS hold time	8		
$t_{su(SI)}$	SDI input setup time	5		
$t_{h(SI)}$	SDI input hold time	15		
$t_{v(SO)}$	SDO valid output time		50	
$t_{h(SO)}$	SDO output hold time	6		
$t_{dis(SO)}$	SDO output disable time		50	

1. Values are guaranteed at 10 MHz clock frequency for SPI, based on characterization results, not tested in production.

Figure 4. SPI slave timing diagram

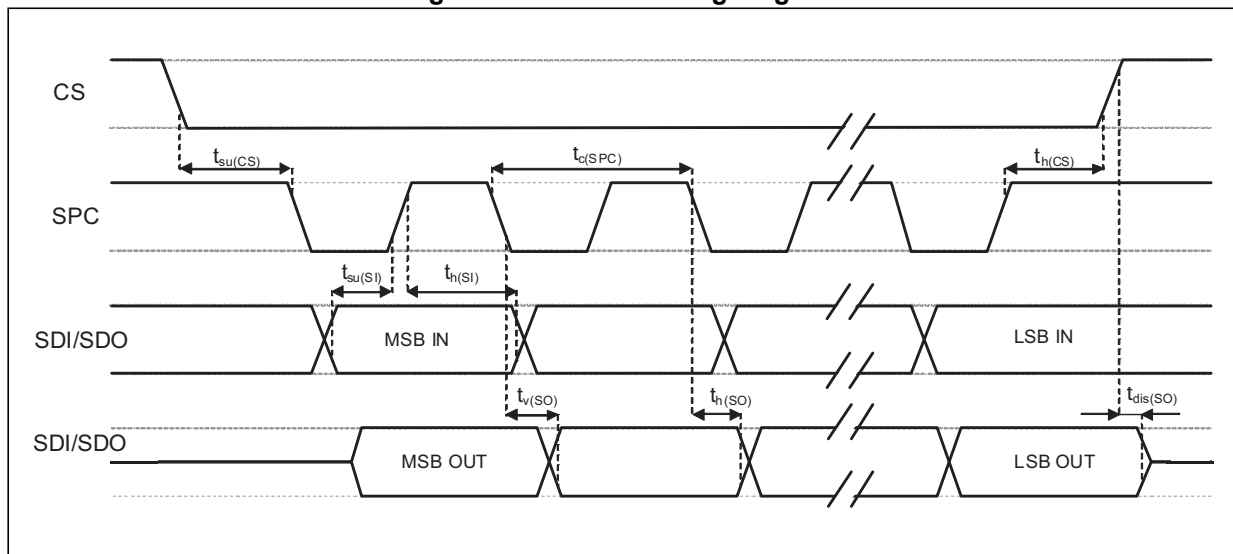

Note: Measurement points are done at $0.2 \cdot V_{dd_IO}$ and $0.8 \cdot V_{dd_IO}$, for both input and output ports.

3.5 Absolute maximum ratings

Stresses above those listed as “absolute maximum ratings” may cause permanent damage to the device. This is a stress rating only and functional operation of the device under these conditions is not implied. Exposure to maximum rating conditions for extended periods may affect device reliability.

Absolute maximum ratings

Symbol	Ratings	Maximum value	Unit
AVdd	Supply voltage	-0.3 to 4.8	V
HAVdd	Supply voltage	-0.3 to 4.8	V
Vdd_IO	Vdd IO	-0.3 to Vdd	V
Vin	Input voltage on: (CS, SDI/SDO, SCL)	-0.3 to Vdd_IO +0.1	V
T _{STG}	Storage temperature range	-40 to +125	°C
Sg	Acceleration <i>g</i> for 0.1 ms	10,000	<i>g</i>
ESD	Electrostatic discharge protection	2 (HBM)	kV

Note: Supply voltage on any pin should never exceed 4.8 V.



This device is sensitive to mechanical shock, improper handling can cause permanent damage to the part.



This device is sensitive to electrostatic discharge (ESD), improper handling can cause permanent damage to the part.

4 Application hints

Figure 5. L2G3IS electrical connections and external component values

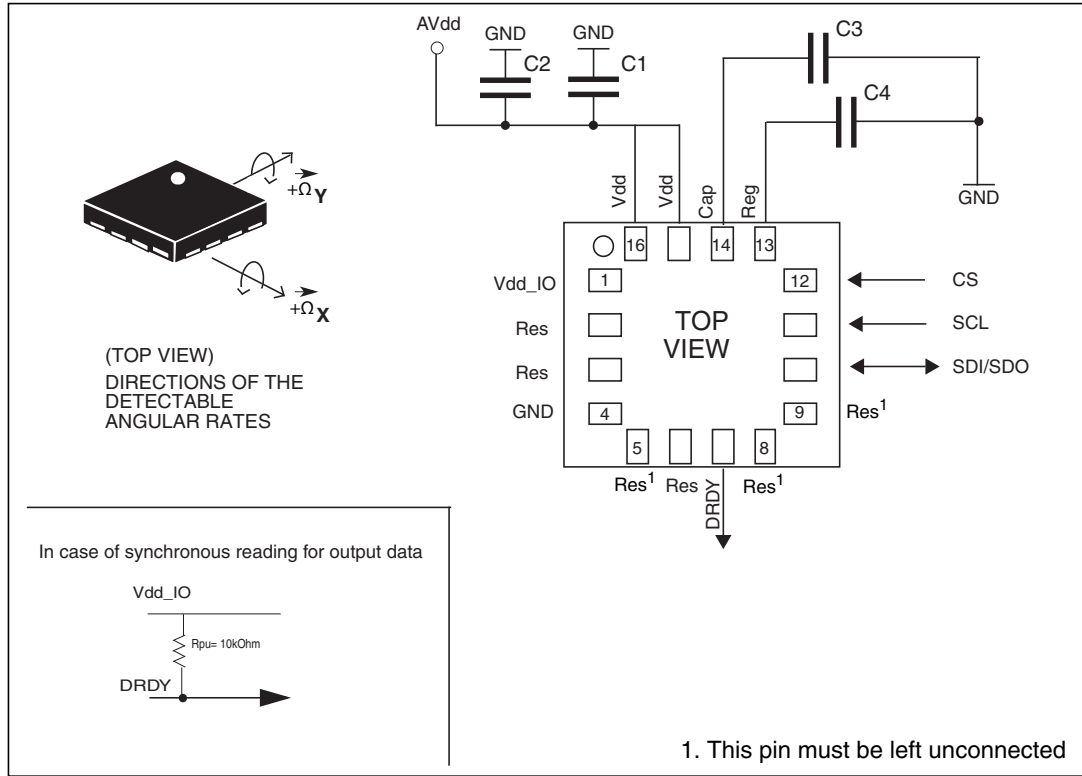

Table 7. External components

Type description	Value	Purpose
C1	1 μF	Decoupling
C2	100 pF	Decoupling
C3 ⁽¹⁾	10 nF (16 V class)	Charge pump
C4	220 nF (5 V class)	Internal regulator

1. This value must guarantee a minimum of 1 nF value under 12 V bias condition.

Power supply decoupling capacitors (100 pF + 1 μF) should be placed as near as possible to the device (common design practice). A pull-up resistor must be added to the DRDY line (open-drain pad).

5 Digital interfaces

The registers embedded inside the L2G3IS may be accessed through the SPI serial interfaces.

Table 8. Serial interface pin description

Pin name	Pin description
CS	Chip-select line
SCL	SPI serial port clock
SDI/SDO	SPI serial data input/output

5.1 SPI bus interface

The SPI is a bus slave. The SPI allows to write and read the registers of the device.

The serial interface interacts with the outside world with 3 wires: **CS**, **SCL**, **SDI/SDO**.

CS is the serial port enable and it is controlled by the SPI master. It goes low at the start of the transmission and goes back high at the end. **SCL** is the serial port clock and it is controlled by the SPI master. It is stopped high when **CS** is high (no transmission). **SDI/SDO** is the serial port data input and output. This line is driven at the falling edge of **SCL** and should be captured at the rising edge of **SCL**.

Both the read register and write register commands are completed in 16 clock pulses or in multiples of 8 in case of multiple read/write bytes. Bit duration is the time between two falling edges of **SCL**. The first bit (bit 0) starts at the first falling edge of **SCL** after the falling edge of **CS** while the last bit (bit 15, bit 23, ...) starts at the last falling edge of **SCL** just before the rising edge of **CS**.

5.1.1 SPI write

Figure 6. SPI write protocol

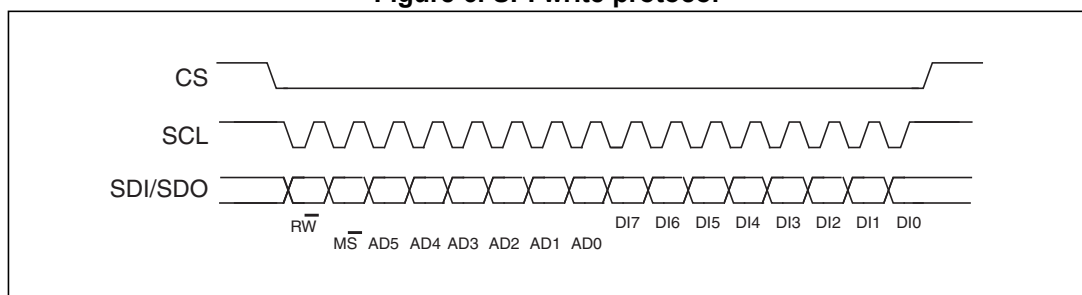

The SPI write command is performed with 16 clock pulses. A multiple byte write command is performed by adding blocks of 8 clock pulses to the previous one.

bit 0: WRITE bit. The value is 0.

bit 1: \overline{MS} bit. When 0, does not increment the address; when 1, increments the address in multiple writes.

bit 2 -7: address AD(5:0). This is the address field of the indexed register.

bit 8-15: data DI(7:0) (write mode). This is the data that will be written inside the device (MSb first).

bit 16-... : data DI(...-8). Further data in multiple byte writes.

Figure 7. Multiple byte SPI write protocol (2-byte example)

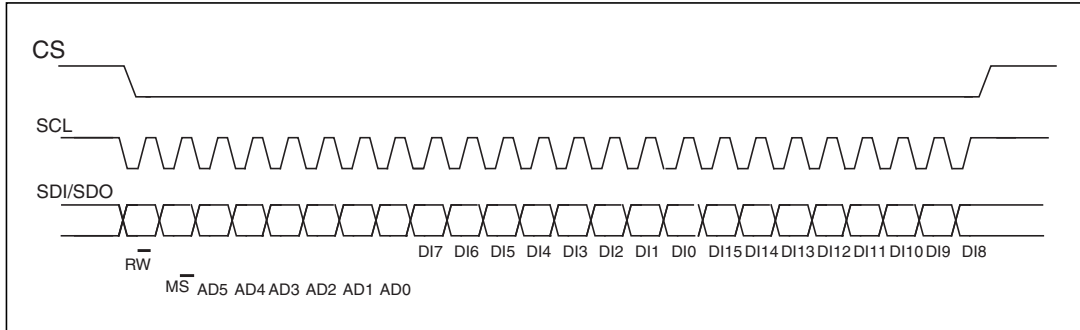

5.1.2 SPI read

Figure 8. SPI read protocol

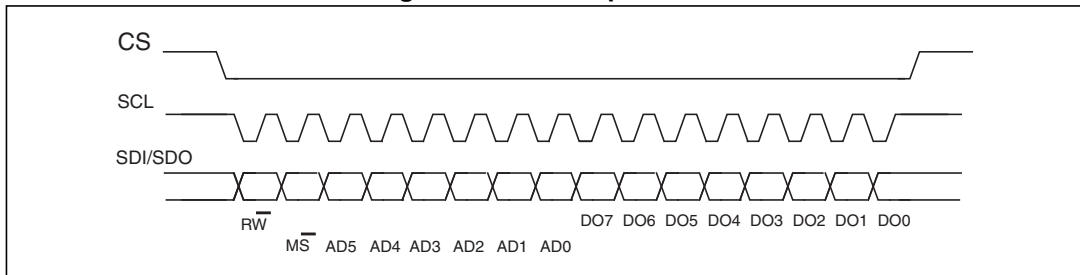

The SPI read command is performed with 16 clock pulses:

bit 0: READ bit. The value is 1.

bit 1: \overline{MS} bit. When 0, does not increment the address; when 1, increments the address in multiple reads.

bit 2-7: address AD(5:0). This is the address field of the indexed register.

bit 8-15: data DO(7:0) (read mode). This is the data that will be read from the device (MSb first).

A multiple read command is also available.

6 Output register mapping

The table given below provides a listing of the 8-bit registers embedded in the device and the related addresses.

Table 9. Register address map

Name	Type	Register address [Hex]	Default [Hex]	Comment
Reserved	--	00-02	--	Reserved
OUT_X_L	r	03	output	
OUT_X_H	r	04	output	
OUT_Y_L	r	05	output	
OUT_Y_H	r	06	output	
Reserved	r	07-08	--	Reserved
STATUS_REG	r	09	output	
Reserved	--	0A	--	Reserved
CTRL_REG1	rw	0B	01	
CTRL_REG2	rw	0C	00	
CTRL_REG3	rw	0D	00	
ORIENT_CONFIG	rw	10	00	
Reserved	--	11-14	--	Reserved
CTRL_REG4	rw	15	00	
Reserved	--	16-1E	--	Reserved
CTRL_REG5	rw	1F	00	
CTRL_TEMP	rw	20	04	
Reserved	--	21-25	--	Reserved
OUT_TEMP	r	26	output	

Registers marked as Reserved must not be changed. Writing to those registers may cause permanent damage to the device.

To guarantee proper behavior of the device, all register addresses not listed in the above table must not be accessed and the content stored in those registers must not be changed.

The content of the registers that are loaded at boot should not be changed. They contain the factory calibration values. Their content is automatically restored when the device is powered up.

7 Register description

The device contains a set of registers which are used to control its behavior and to retrieve angular rate data. The register address, consisting of 7 bits, is used to identify them and to write the data through the serial interface.

7.1 OUT_X_L (03h), OUT_X_H (04h)

X-axis angular rate data. The value is expressed as two's complement.

7.2 OUT_Y_L (05h), OUT_Y_H (06h)

Y-axis angular rate data. The value is expressed as two's complement.

7.3 STATUS_REG (09h)

Table 10. STATUS_REG register

YXOR	XOR	YOR	0	YXDA	XDA	YDA	0
------	-----	-----	---	------	-----	-----	---

Table 11. STATUS_REG description

YXOR	X, Y-axis data overrun. Default value: 0 (0: no overrun has occurred; 1: new data has overwritten the previous data before it was read)
XOR	X-axis data overrun. Default value: 0 (0: no overrun has occurred; 1: new data for the X-axis has overwritten the previous data)
YOR	Y-axis data overrun. Default value: 0 (0: no overrun has occurred; 1: new data for the Y-axis has overwritten the previous data)
YXDA	X, Y-axis new data available. Default value: 0 (0: a new set of data is not yet available; 1: a new set of data is available)
XDA	X-axis new data available. Default value: 0 (0: new data for the X-axis is not yet available; 1: new data for the X-axis is available)
YDA	Y-axis new data available. Default value: 0 (0: new data for the Y-axis is not yet available; 1: new data for the Y-axis is available)

7.4 CTRL_REG1 (0Bh)

Table 12. CTRL_REG1 register

0 ⁽¹⁾	0 ⁽¹⁾	0 ⁽¹⁾	0 ⁽¹⁾	BDU	REG_EN	PW1	PW0
------------------	------------------	------------------	------------------	-----	--------	-----	-----

1. These bits must be set to '0' for proper operation of the device.

Table 13. CTRL_REG1 description

BDU	Block data update. Default value: 0. (0: output registers not updated until MSB and LSB have been read; 1: output registers updated continuously)
REG_EN	Enables writing to <i>CTRL_REG4 (15h)</i> , <i>CTRL_REG5 (1Fh)</i> and <i>CTRL_TEMP (20h)</i> . Default value: 0 (1: enable write values in <i>CTRL_REG4 (15h)</i> , <i>CTRL_REG5 (1Fh)</i>) and <i>CTRL_TEMP (20h)</i>)
PW[1:0]	Operating mode selection. Default: 01. Refer to <i>Table 14: Operating mode selection</i> .

Table 14. Operating mode selection

PW1	PW0	Operating mode selection
0	0	Power-down
0	1	Power-down
1	0	Sleep mode
1	1	Normal mode

7.5 CTRL_REG2 (0Ch)

Table 15. CTRL_REG2 register

0 ⁽¹⁾	0 ⁽¹⁾	0 ⁽¹⁾	HPFreset0	HPFreset1	0 ⁽¹⁾	SWreset	HPF
------------------	------------------	------------------	-----------	-----------	------------------	---------	-----

1. These bits must be set to '0' for proper operation of the device.

Table 16. CTRL_REG2 description

HPFreset0	High-pass filter reset. Default: 0 To reset the HPF, HPFreset1 or HPFreset0 has to be set to 1. (1: HPF reset on X-axis and Y-axis)
HPFreset1	High-pass filter reset. Default: 0 To reset the HPF, HPFreset1 or HPFreset0 has to be set to 1. (1: HPF reset on X-axis and Y-axis)
SWreset	Software reset. Default: 0. (1: all control and output register values are restored to default values).
HPF	High-pass filter enable. Default: 0. (0: high-pass filter is disabled; 1: high-pass filter is enabled)

7.6 CTRL_REG3 (0Dh)

Table 17. CTRL_REG3 register

0 ⁽¹⁾	0 ⁽¹⁾	0 ⁽¹⁾	0 ⁽¹⁾	0 ⁽¹⁾	0 ⁽¹⁾	0 ⁽¹⁾	LPF
------------------	------------------	------------------	------------------	------------------	------------------	------------------	-----

1. These bits must be set to '0' for proper operation of the device.

Table 18. CTRL_REG3 description

LPF	Low-pass filter cutoff frequency selection. Default value 0. (0: 120 Hz; 1: 370 Hz). If LPF2 in CTRL_REG5 (1Fh) is set to '1', the cutoff frequency is set to 240 Hz, independently of the value of LPF.
-----	---

Table 19. Low-pass filter cutoff frequency

LPF	LPF2 (CTRL_REG5 (1Fh))	Low-pass filter cutoff frequency selection
0	0	120 Hz
1	0	370 Hz
0	1	240 Hz
1	1	240 Hz

7.7 ORIENT_CONFIG (10h)

Table 20. ORIENT_CONFIG register

0 ⁽¹⁾	0 ⁽¹⁾	Sign_x	Sign_y	0 ⁽¹⁾	Orient_2	Orient_1	Orient_0
------------------	------------------	--------	--------	------------------	----------	----------	----------

1. These bits must be set to '0' for proper operation of the device.

Table 21. ORIENT_CONFIG description

Sign_x	X-axis angular rate sign. Default 0. (0: sign unvaried; 1: sign inverted)
Sign_y	Y-axis angular rate sign. Default 0. (0: sign unvaried; 1: sign inverted)
Orient[2:0]	Directional orientation selection. Default 000. Refer to Table 22: Directional orientation selection .

Table 22. Directional orientation selection

Orient_2	Orient_1	Orient_0	Directional orientation selection
0	0	0	x-axis - y-axis
0	1	0	y-axis - x-axis

7.8 CTRL_REG4 (15h)

To enable writing to the [CTRL_REG4 \(15h\)](#) register, the REG_EN bit in [CTRL_REG1 \(0Bh\)](#) has to be set to '1'.

Table 23. CTRL_REG4 register

0 ⁽¹⁾	0 ⁽¹⁾	0 ⁽¹⁾	0 ⁽¹⁾	0 ⁽¹⁾	0 ⁽¹⁾	0 ⁽¹⁾	DRDY_EN
------------------	------------------	------------------	------------------	------------------	------------------	------------------	---------

1. These bits must be set to '0' for proper operation of the device

Table 24. CTRL_REG4 description

DRDY_EN	Data ready enable on DRDY pin. Default 0. (1: DRDY on pin). Refer to Section 2.3: Synchronous reading .
---------	--

7.9 CTRL_REG5 (1Fh)

To enable writing to the [CTRL_REG5 \(1Fh\)](#) register, the REG_EN bit in [CTRL_REG1 \(0Bh\)](#) has to be set to '1'.

Table 25. CTRL_REG5 register

--	--	--	--	FS	LPF2	HPF_BW1	HPF_BW0
----	----	----	----	----	------	---------	---------

Table 26. CTRL_REG5 description

FS	Full-scale selection. Default value: 0 (0: ± 65 dps; 1: ± 130 dps)
LPF2	Enable low-pass filter 240 Hz. Default 0. If LPF2 is enabled, the cutoff frequency is set to 240 Hz, independently of the value of the LPF bit in CTRL_REG3 (0Dh) . Refer to Table 19: Low-pass filter cutoff frequency .
HPF_BW[1:0]	Digital high-pass filter cutoff frequency selection. Default value 00. Refer to Table 27: High-pass filter cutoff frequency selection

Table 27. High-pass filter cutoff frequency selection

HPF_BW1	HPF_BW0	HP cutoff frequency selection
0	0	0.02 Hz
0	1	0.08 Hz
1	0	4.85 Hz
1	1	39.6 Hz

7.10 CTRL_TEMP (20h)

To enable writing to the *CTRL_TEMP (20h)* register, the REG_EN bit in *CTRL_REG1 (0Bh)* has to be set to '1'.

Table 28. CTRL_TEMP register

0 ⁽¹⁾	0 ⁽¹⁾	0 ⁽¹⁾	0 ⁽¹⁾	TEMP_EN	1 ⁽²⁾	0 ⁽¹⁾	0 ⁽¹⁾
------------------	------------------	------------------	------------------	---------	------------------	------------------	------------------

1. These bits must be set to '0' for proper operation of the device.
2. This bit must be left at '1' for proper operation of the device.

Table 29. CTRL_TEMP description

TEMP_EN	Temperature sensor enable. Default 0 (0: temperature sensor is disabled; 1: temperature sensor is enabled). Refer to: Section 2.4: Temperature sensor on how to enable and read the temperature sensor output data.
---------	---

7.11 OUT_TEMP (26h)

Table 30. OUT_TEMP register

Temp7	Temp6	Temp5	Temp4	Temp3	Temp2	Temp1	Temp0
-------	-------	-------	-------	-------	-------	-------	-------

Table 31. OUT_TEMP description

Temp7-Temp0	Temperature data. The value is expressed as two's complement left-justified. The output of the temperature sensor is 0 at 25 °C. Refer to: Section 2.4: Temperature sensor on how to enable and read the temperature sensor output data.
-------------	--

8 Soldering information

The LGA package is compliant with the ECOPACK[®], RoHS and “Green” standard. It is qualified for soldering heat resistance according to JEDEC J-STD-020.

Leave “Pin 1 Indicator” unconnected during soldering.

Land pattern and soldering recommendations are available at www.st.com/mems.

9 Package information

In order to meet environmental requirements, ST offers these devices in different grades of ECOPACK® packages, depending on their level of environmental compliance. ECOPACK specifications, grade definitions and product status are available at: www.st.com. ECOPACK is an ST trademark.

Figure 9. LGA-16: mechanical data and package dimensions

Dimensions (mm)			
Ref.	Min.	Typ.	Max.
A1			1
A2		0.785	
A3		0.200	
D1	2.850	3.000	3.150
E1		3.500	
L		1.750	
N		0.500	
M	0.040	0.100	0.160
M1	0.290	0.350	0.410
P		1.200	
T1	0.290	0.350	0.410
T2	0.190	0.250	0.310
d		0.150	
k		0.050	

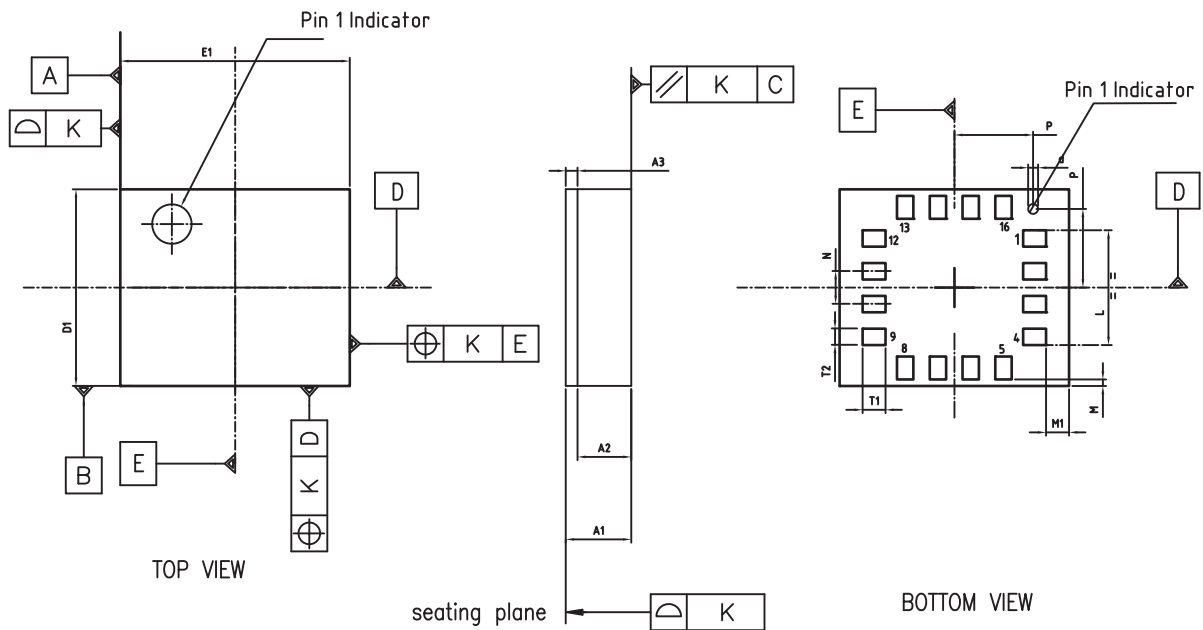

8409170_A

10 Revision history

Table 32. Document revision history

Date	Revision	Changes
16-Jul-2013	1	Initial release
28-Aug-2013	2	Updated <i>Figure 5: L2G3IS electrical connections and external component values</i> Moved <i>Figure 2: Digital block diagram</i>
05-Dec-2013	3	Document status promoted from preliminary data to production data; updated <i>Table 15: CTRL_REG2 register</i> and <i>Table 16: CTRL_REG2 description</i>

Please Read Carefully:

Information in this document is provided solely in connection with ST products. STMicroelectronics NV and its subsidiaries ("ST") reserve the right to make changes, corrections, modifications or improvements, to this document, and the products and services described herein at any time, without notice.

All ST products are sold pursuant to ST's terms and conditions of sale.

Purchasers are solely responsible for the choice, selection and use of the ST products and services described herein, and ST assumes no liability whatsoever relating to the choice, selection or use of the ST products and services described herein.

No license, express or implied, by estoppel or otherwise, to any intellectual property rights is granted under this document. If any part of this document refers to any third party products or services it shall not be deemed a license grant by ST for the use of such third party products or services, or any intellectual property contained therein or considered as a warranty covering the use in any manner whatsoever of such third party products or services or any intellectual property contained therein.

UNLESS OTHERWISE SET FORTH IN ST'S TERMS AND CONDITIONS OF SALE ST DISCLAIMS ANY EXPRESS OR IMPLIED WARRANTY WITH RESPECT TO THE USE AND/OR SALE OF ST PRODUCTS INCLUDING WITHOUT LIMITATION IMPLIED WARRANTIES OF MERCHANTABILITY, FITNESS FOR A PARTICULAR PURPOSE (AND THEIR EQUIVALENTS UNDER THE LAWS OF ANY JURISDICTION), OR INFRINGEMENT OF ANY PATENT, COPYRIGHT OR OTHER INTELLECTUAL PROPERTY RIGHT.

ST PRODUCTS ARE NOT DESIGNED OR AUTHORIZED FOR USE IN: (A) SAFETY CRITICAL APPLICATIONS SUCH AS LIFE SUPPORTING, ACTIVE IMPLANTED DEVICES OR SYSTEMS WITH PRODUCT FUNCTIONAL SAFETY REQUIREMENTS; (B) AERONAUTIC APPLICATIONS; (C) AUTOMOTIVE APPLICATIONS OR ENVIRONMENTS, AND/OR (D) AEROSPACE APPLICATIONS OR ENVIRONMENTS. WHERE ST PRODUCTS ARE NOT DESIGNED FOR SUCH USE, THE PURCHASER SHALL USE PRODUCTS AT PURCHASER'S SOLE RISK, EVEN IF ST HAS BEEN INFORMED IN WRITING OF SUCH USAGE, UNLESS A PRODUCT IS EXPRESSLY DESIGNATED BY ST AS BEING INTENDED FOR "AUTOMOTIVE, AUTOMOTIVE SAFETY OR MEDICAL" INDUSTRY DOMAINS ACCORDING TO ST PRODUCT DESIGN SPECIFICATIONS. PRODUCTS FORMALLY ESCC, QML OR JAN QUALIFIED ARE DEEMED SUITABLE FOR USE IN AEROSPACE BY THE CORRESPONDING GOVERNMENTAL AGENCY.

Resale of ST products with provisions different from the statements and/or technical features set forth in this document shall immediately void any warranty granted by ST for the ST product or service described herein and shall not create or extend in any manner whatsoever, any liability of ST.

ST and the ST logo are trademarks or registered trademarks of ST in various countries.

Information in this document supersedes and replaces all information previously supplied.

The ST logo is a registered trademark of STMicroelectronics. All other names are the property of their respective owners.

© 2013 STMicroelectronics - All rights reserved

STMicroelectronics group of companies

Australia - Belgium - Brazil - Canada - China - Czech Republic - Finland - France - Germany - Hong Kong - India - Israel - Italy - Japan - Malaysia - Malta - Morocco - Philippines - Singapore - Spain - Sweden - Switzerland - United Kingdom - United States of America

www.st.com