

General Purpose Amplifier NPN Silicon Transistor

This NPN transistor is designed for general purpose amplifier applications. This device is housed in the SOT-723 package which is designed for low power surface mount applications, where board space is at a premium.

- Reduces Board Space
- High h_{FE} , 210–460 (typical)
- Low $V_{CE(sat)}$, < 0.5 V
- ESD Performance: Human Body Model; > 2000 V, Machine Model; > 200 V
- Available in 8 mm, 7-inch/3000 Unit Tape and Reel
- This is a Pb-Free Device
- We declare that the material of product compliance with RoHS requirements.

L2SC5658M3T5G

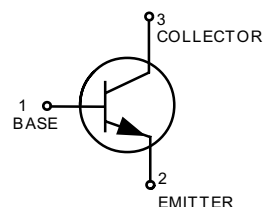
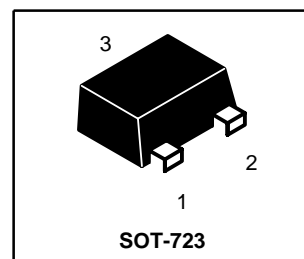

MAXIMUM RATINGS ($T_A = 25^\circ\text{C}$)

Rating	Symbol	Value	Unit
Collector-Base Voltage	$V_{(BR)CBO}$	50	Vdc
Collector-Emitter Voltage	$V_{(BR)CEO}$	50	Vdc
Emitter-Base Voltage	$V_{(BR)EBO}$	5.0	Vdc
Collector Current – Continuous	I_C	100	mAdc

THERMAL CHARACTERISTICS

Rating	Symbol	Max	Unit
Power Dissipation (Note 1)	P_D	260	mW
Junction Temperature	T_J	150	$^\circ\text{C}$
Storage Temperature Range	T_{stg}	-55 ~ +150	$^\circ\text{C}$

1. Device mounted on a FR-4 glass epoxy printed circuit board using the minimum recommended footprint.

ORDERING INFORMATION

Device	Marking	Shipping
L2SC5658M3T5G	139	5000/Tape & Reel

L2SC5658M3T5G

ELECTRICAL CHARACTERISTICS ($T_A = 25^\circ\text{C}$)

Characteristic	Symbol	Min	Typ	Max	Unit
Collector-Base Breakdown Voltage ($I_C = 50 \mu\text{Adc}$, $I_E = 0$)	$V_{(BR)CBO}$	50	–	–	Vdc
Collector-Emitter Breakdown Voltage ($I_C = 1.0 \text{ mAdc}$, $I_B = 0$)	$V_{(BR)CEO}$	50	–	–	Vdc
Emitter-Base Breakdown Voltage ($I_E = 50 \mu\text{Adc}$, $I_C = 0$)	$V_{(BR)EBO}$	5.0	–	–	Vdc
Collector-Base Cutoff Current ($V_{CB} = 30 \text{ Vdc}$, $I_E = 0$)	I_{CBO}	–	–	0.5	μA
Emitter-Base Cutoff Current ($V_{EB} = 4.0 \text{ Vdc}$, $I_B = 0$)	I_{EBO}	–	–	0.5	μA
Collector-Emitter Saturation Voltage (Note 2) ($I_C = 60 \text{ mAdc}$, $I_B = 5.0 \text{ mAdc}$)	$V_{CE(sat)}$	–	–	0.4	Vdc
DC Current Gain (Note 2) ($V_{CE} = 6.0 \text{ Vdc}$, $I_C = 1.0 \text{ mAdc}$)	h_{FE}	120	–	560	–
Transition Frequency ($V_{CE} = 12 \text{ Vdc}$, $I_C = 2.0 \text{ mAdc}$, $f = 30 \text{ MHz}$)	f_T	–	180	–	MHz
Output Capacitance ($V_{CB} = 12 \text{ Vdc}$, $I_C = 0 \text{ Adc}$, $f = 1.0 \text{ MHz}$)	C_{OB}	–	2.0	–	pF

2. Pulse Test: Pulse Width $\leq 300 \mu\text{s}$, D.C. $\leq 2\%$.

TYPICAL ELECTRICAL CHARACTERISTICS

L2SC5658M3T5G

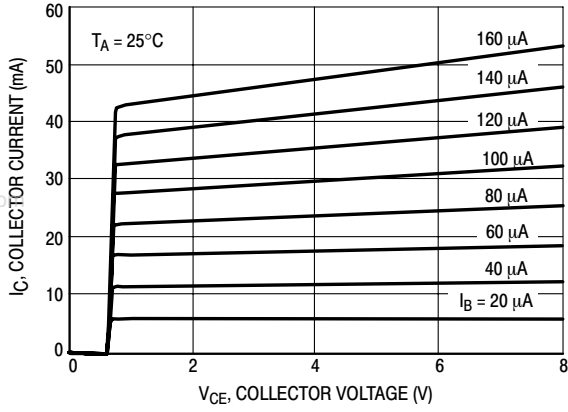

Figure 1. $I_C - V_{CE}$

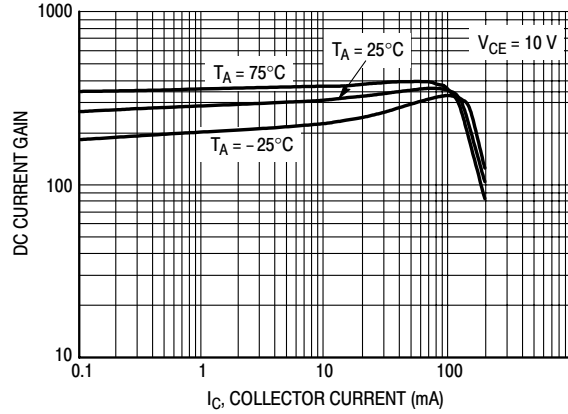

Figure 2. DC Current Gain

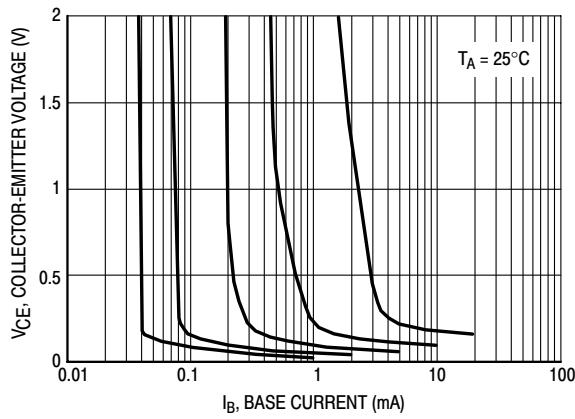

Figure 3. Collector Saturation Region

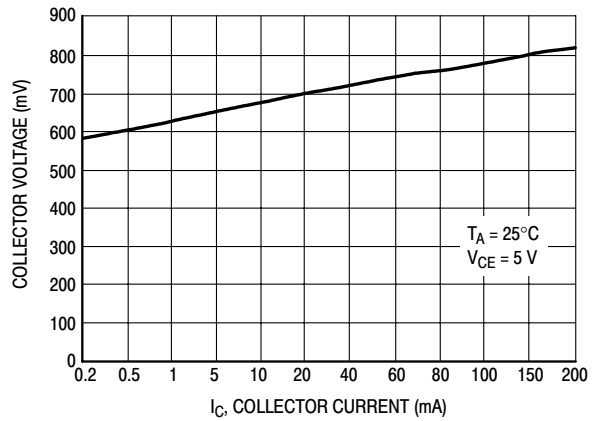

Figure 4. On Voltage

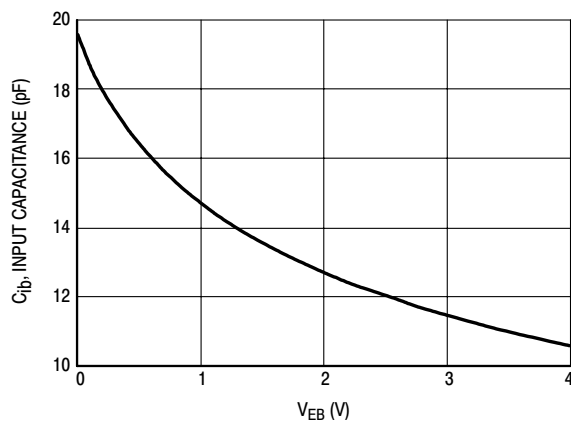

Figure 5. Capacitance

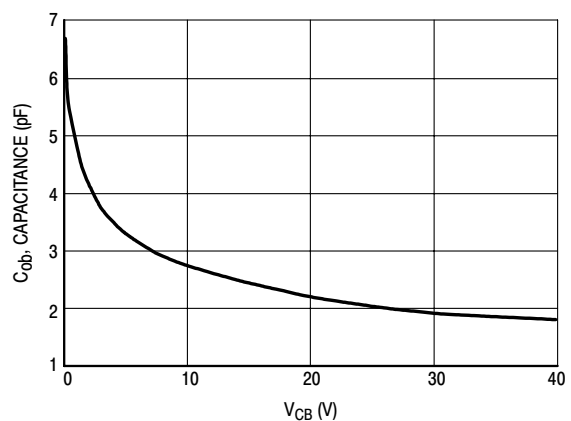

Figure 6. Capacitance

L2SC5658M3T5G

PACKAGE DIMENSIONS

SOT-723

www.DataSheet4U.com

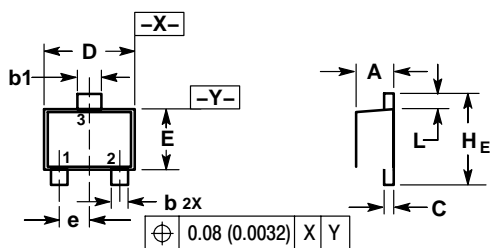

NOTES:

1. DIMENSIONING AND TOLERANCING PER ANSI Y14.5M, 1982.
2. CONTROLLING DIMENSION: MILLIMETERS.
3. MAXIMUM LEAD THICKNESS INCLUDES LEAD FINISH. MINIMUM LEAD THICKNESS IS THE MINIMUM THICKNESS OF BASE MATERIAL.
4. DIMENSIONS D AND E DO NOT INCLUDE MOLD FLASH, PROTRUSIONS OR GATE BURRS.

DIM	MILLIMETERS			INCHES		
	MIN	NOM	MAX	MIN	NOM	MAX
A	0.45	0.50	0.55	0.018	0.020	0.022
b	0.15	0.20	0.27	0.0059	0.0079	0.0106
b1	0.25	0.3	0.35	0.010	0.012	0.014
C	0.07	0.12	0.17	0.0028	0.0047	0.0067
D	1.15	1.20	1.25	0.045	0.047	0.049
E	0.75	0.80	0.85	0.03	0.032	0.034
e	0.40 BSC			0.016 BSC		
H E	1.15	1.20	1.25	0.045	0.047	0.049
L	0.15	0.20	0.25	0.0059	0.0079	0.0098

- PIN 1. BASE
 2. EMITTER
 3. COLLECTOR

SOLDERING FOOTPRINT

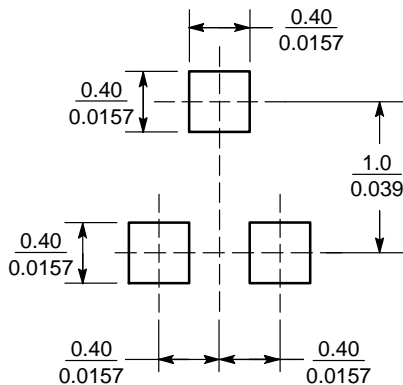

(mm)
 (inches)

EMBOSSED TAPE AND REEL DATA FOR DISCRETES

www.DataSheet4U.com

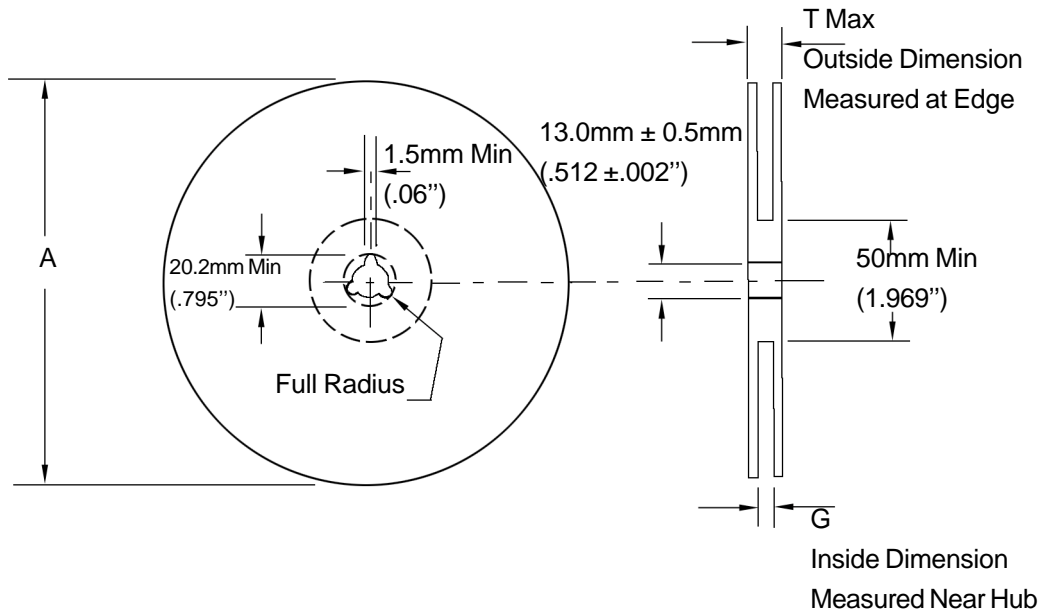

Size	A Max	G	T Max
8 mm	330mm (12.992")	8.4mm+1.5mm, -0.0 (.33"+.059", -0.00)	14.4mm (.56")

Reel Dimensions

Metric Dimensions Govern — English are in parentheses for reference only

Storage Conditions

Temperature: 5 to 40 Deg.C (20 to 30 Deg. C is preferred)

Humidity: 30 to 80 RH (40 to 60 is preferred)

Recommended Period: One year after manufacturing

(This recommended period is for the soldering condition only. The characteristics and reliabilities of the products are not restricted to this limitation)

Shipment Specification

