

◆ABSOLUTE MAXIMUM RATING:(Ta=25°C)

PARAMETER	Test Conditions	Symbol	Value	Unit
Supply Voltage	-	Vcc	3~5	V
Output Voltage	-	Vout	3~5	V
Output Current	-	Io	2.5	mA
Junction Temperature	-	Tj	100	°C
Storage Temperature Range	-	Tstg	-25°C to 85°C	°C
Operating Temperature Range	-	Totr	-25°C to 85°C	°C
Power Consumption	(Tamb ≧ 85°C)	Ptot	50	mw
Soldering Temperature	t ≦ 10s, 1mm from case	Tsd	260	°C

◆ELECTRO-OPTICAL CHARACTERISTICS:(Ta=25°C)

Parameter	Symbol	Min	Typ	Max	Unit	Conditions
Supply Current	Icc	-	0.8	1.5	mA	Iin=0 uA
Max. Input Current	Iin	0.3	-	0.8	mA	Vin=0 V
Max. Voltage Gain	Av	80	95	110	dB	Fin=37.9 KHz Vin=30 uVp-p AGC off
Frequency Range	f	-	37.9	-	KHz	-
Output Pulse Width	tPW1	500	600	700	us	Fin=37.9 KHz burst wave Vin=500 uVp-p
	tPW2	500	600	700	us	Fin=37.9 KHz burst wave Vin=50 uVp-p
Low Level Output Voltage	Vol	-	0.2	0.4	V	-
High Level Output Voltage	Voh	2.8	3.0	-	V	-
Arrival Distance	d	-	16	-	m	L-514EIR1C If=300 mA

1.All dimension are in millimeters(inches).

2.Tolerance is ±0.25mm(0.01")unless otherwise specified.

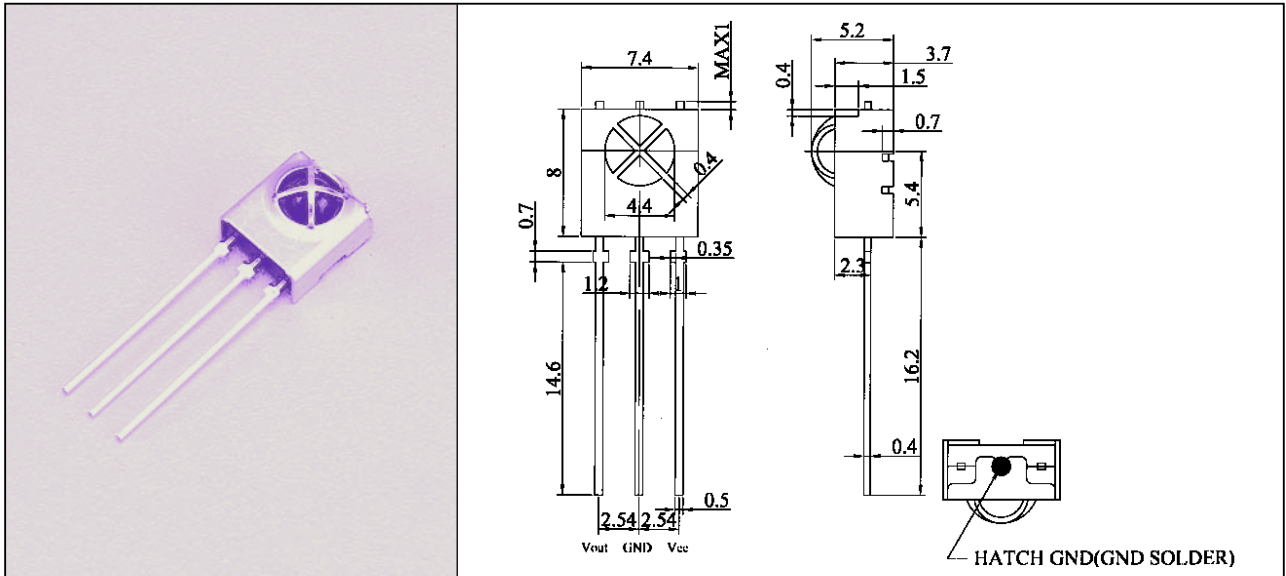

◆ABSOLUTE MAXIMUM RATING:(Ta=25°C)

PARAMETER	Test Conditions	Symbol	Value	Unit
Supply Voltage	-	Vcc	4.5~5.5	V
Output Voltage	-	Vout	4.5~5.5	V
Output Current	-	Io	5	mA
Junction Temperature	-	Tj	100	°C
Storage Temperature Range	-	Tstg	-25°C to 85°C	°C
Operating Temperature Range	-	Totr	-25°C to 85°C	°C
Power Consumption	-	Ptot	50	mw
Soldering Temperature	t ≤10s, 1mm from case	Tsd	260	°C

◆ELECTRO-OPTICAL CHARACTERISTICS:(Ta=25°C)

Parameter	Symbol	Min	Typ	Max	Unit	Conditions
Supply Current	Icc	0.9	1.2	1.5	mA	Iin=0 uA
Max. Input Current	Iin	-	1.0	-	mA	Vin=0 V
Max. Voltage Gain	Av	50	52	53	dB	Fin=37.9 KHz Vin=30 uVp-p AGC off
Frequency Range	f	-	38.0	-	KHz	-
Output Pulse Width	tPW1	500	600	700	us	Fin=37.9 KHz burst wave Vin=500 uVp-p
	tPW2	500	600	700	us	Fin=37.9 KHz burst wave Vin=50 uVp-p
Low Level Output Voltage	Vol	-	0.20	0.25	V	-
High Level Output Voltage	Voh	4.5	-	5.5	V	-
Arrival Distance	d	-	35	-	m	L-514EIR1C If=300 mA

1.All dimension are in millimeters(inches).

2.Tolerance is ±0.25mm(0.01")unless otherwise specified.

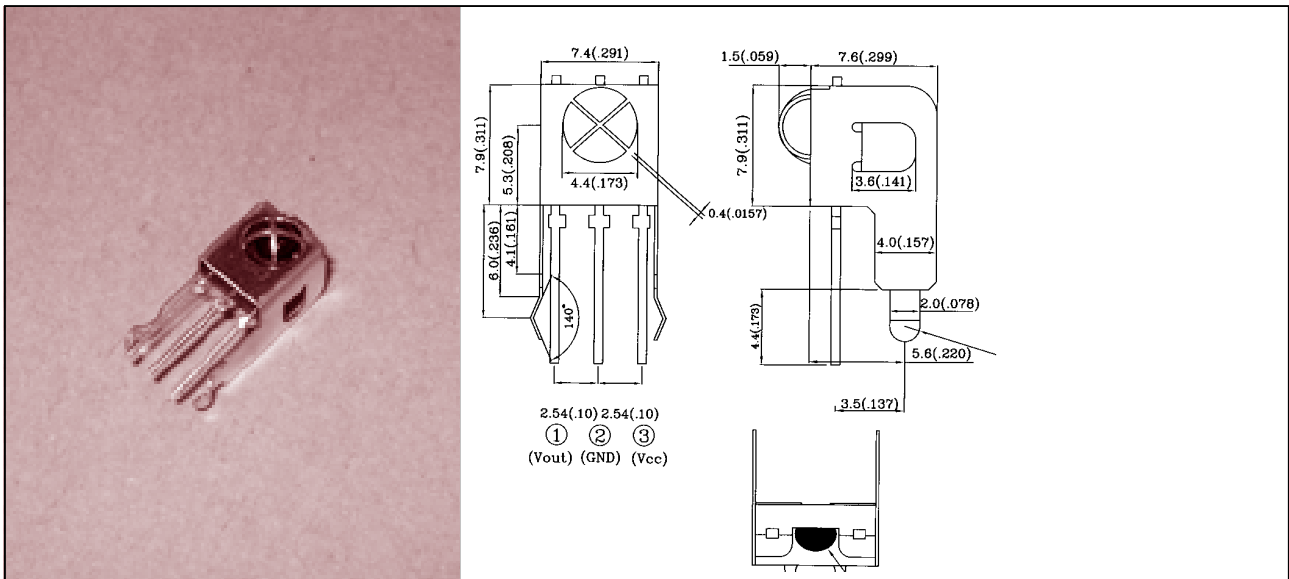

◆ABSOLUTE MAXIMUM RATING:(Ta=25°C)

PARAMETER	Test Conditions	Symbol	Value	Unit
Supply Voltage	-	Vcc	4.5~5.5	V
Output Voltage	-	Vout	4.5~5.5	V
Output Current	-	Io	5	mA
Junction Temperature	-	Tj	100	°C
Storage Temperature Range	-	Tstg	-25°C to 85°C	°C
Operating Temperature Range	-	Totr	-25°C to 85°C	°C
Power Consumption	-	Ptot	50	mw
Soldering Temperature	t ≤ 10s, 1mm from case	Tsd	260	°C

◆ELECTRO-OPTICAL CHARACTERISTICS:(Ta=25°C)

Parameter	Symbol	Min	Typ	Max	Unit	Conditions
Supply Current	Icc	0.9	1.2	1.5	mA	Iin=0 uA
Max. Input Current	Iin(max)	-	1	-	mA	Vin ≥ 0V ; Vs=5V Tamb=25°C
Max. Voltage Gain	Av	50	52	53	dB	Fin=37.9 KHz Vin=30 uVp-p AGC off
Frequency Range	f	-	38.0	-	KHz	-
Output Pulse Width	tPW1	500	600	700	us	Fin=37.9 KHz burst wave Vin=500 uVp-p
	tPW2	500	600	700	us	Fin=37.9 KHz burst wave Vin=50 uVp-p
Low Level Output Voltage	Vol	-	0.20	0.25	V	-
Hight Level Output Voltage	Voh	4.5	-	5.5	V	-
Arrival Distance	d	-	35	-	m	L-514EIR1C IF=300 mA

1.All dimension are in millimeters(inches).

2.Tolerance is ±0.25mm(0.01")unless otherwise specified.

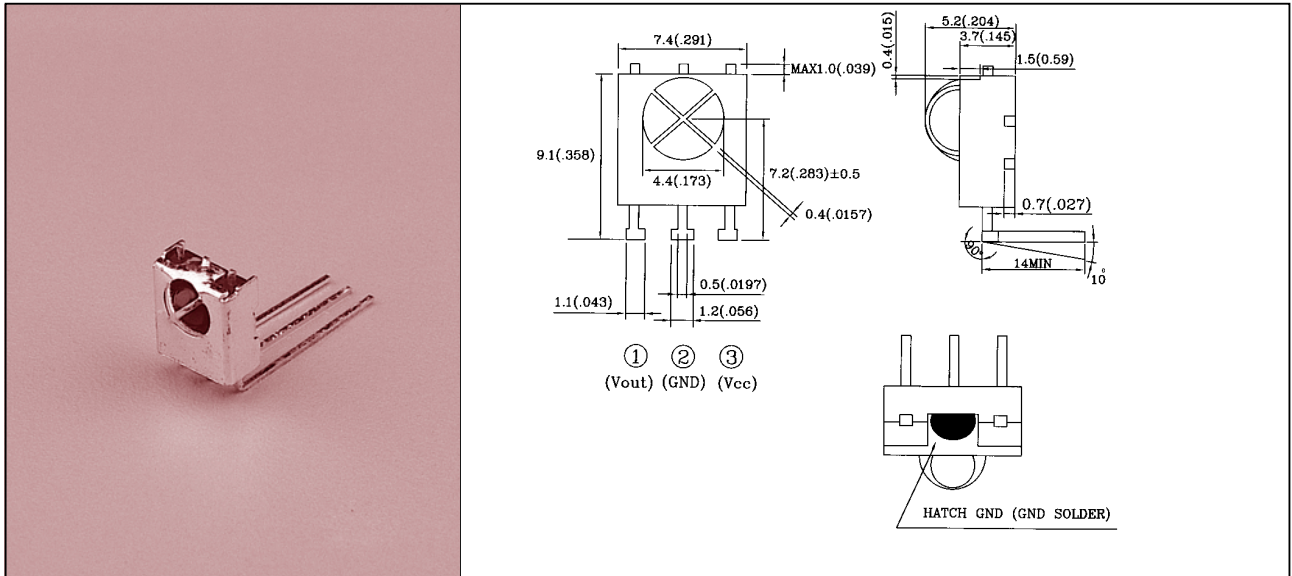

◆ABSOLUTE MAXIMUM RATING:(Ta=25°C)

PARAMETER	Test Conditions	Symbol	Value	Unit
Supply Voltage	-	Vcc	4.5~5.5	V
Output Voltage	-	Vout	4.5~5.5	V
Output Current	-	Io	5	mA
Junction Temperature	-	Tj	100	°C
Storage Temperature Range	-	Tstg	-25°C to 85°C	°C
Operating Temperature Range	-	Totr	-25°C to 85°C	°C
Power Consumption	-	Ptot	50	mw
Soldering Temperature	t ≤ 10s, 1mm from case	Tsd	260	°C

◆ELECTRO-OPTICAL CHARACTERISTICS:(Ta=25°C)

Parameter	Symbol	Min	Typ	Max	Unit	Conditions
Supply Current	Icc	0.9	1.2	1.5	mA	Iin=0 uA
Max. Input Current	Iin(max)	-	1	-	mA	Vin ≥ 0V ; VS=5V Tamb=25°C
Max. Voltage Gain	Av	50	52	53	dB	Fin=37.9 KHz Vin=30 uVp-p AGC off
Frequency Range	f	-	38.0	-	KHz	-
Output Pulse Width	tPW1	500	600	700	us	Fin=37.9 KHz burst wave Vin=500 uVp-p
	tPW2	500	600	700	us	Fin=37.9 KHz burst wave Vin=50 uVp-p
Low Level Output Voltage	Vol	-	0.20	0.25	V	-
Hight Level Output Voltage	Voh	4.5	-	5.5	V	-
Arrival Distance	d	-	35	-	m	L-514EIR1C IF=300 mA

1.All dimension are in millimeters(inches).

2.Tolerance is ±0.25mm(0.01")unless otherwise specified.

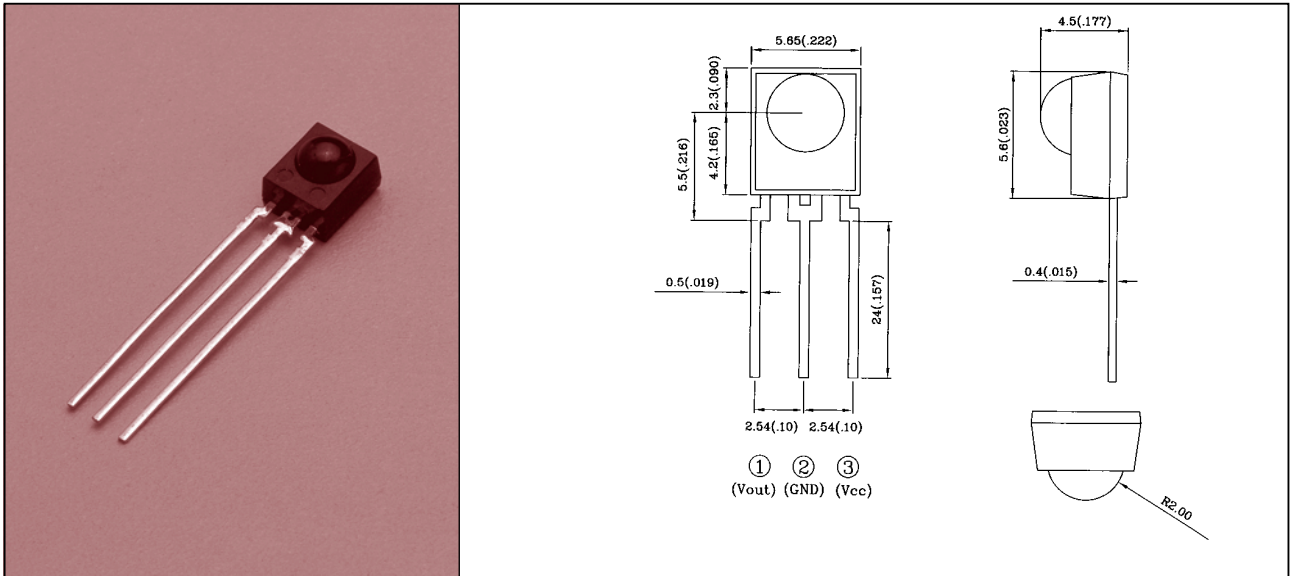

◆ABSOLUTE MAXIMUM RATING:(Ta=25°C)

PARAMETER	Test Conditions	Symbol	Value	Unit
Supply Voltage	-	Vcc	4.5~5.5	V
Output Voltage	-	Vout	4.5~5.5	V
Output Current	-	Io	5	mA
Junction Temperature	-	Ti	100	°C
Storage Temperature Range	-	Tstg	-25°C to 85°C	°C
Operating Temperature Range	-	Totr	-25°C to 85°C	°C
Power Consumption	-	Ptot	50	mw
Soldering Temperature	t ≤ 10s, 1mm from case	Tsd	260	°C

◆ELECTRO-OPTICAL CHARACTERISTICS:(Ta=25°C)

Parameter	Symbol	Min	Typ	Max	Unit	Conditions
Supply Current	Icc	0.9	1.2	1.5	mA	Iin=0 uA
Max. Input Current	Iin(max)	-	1	-	mA	Vin ≥ 0V ; VS=5V Tamb=25°C
Max. Voltage Gain	Av	50	52	53	dB	Fin=37.9 KHz Vin=30 uVp-p AGC off
Frequency Range	f	-	38.0	-	KHz	-
Output Pulse Width	tPW1	500	600	700	us	Fin=37.9 KHz burst wave Vin=500 uVp-p
	tPW2	500	600	700	us	Fin=37.9 KHz burst wave Vin=50 uVp-p
Low Level Output Voltage	Vol	-	0.20	0.25	V	-
Hight Level Output Voltage	Voh	4.5		5.5	V	-
Arrival Distance	d	-	35	-	m	L-514EIR1C IF=300 mA

1.All dimension are in millimeters(inches).

2.Tolerance is ±0.25mm(0.01")unless otherwise specified.

L-31ROPT1XX 3.0mm PHOTOTRANSISTOR

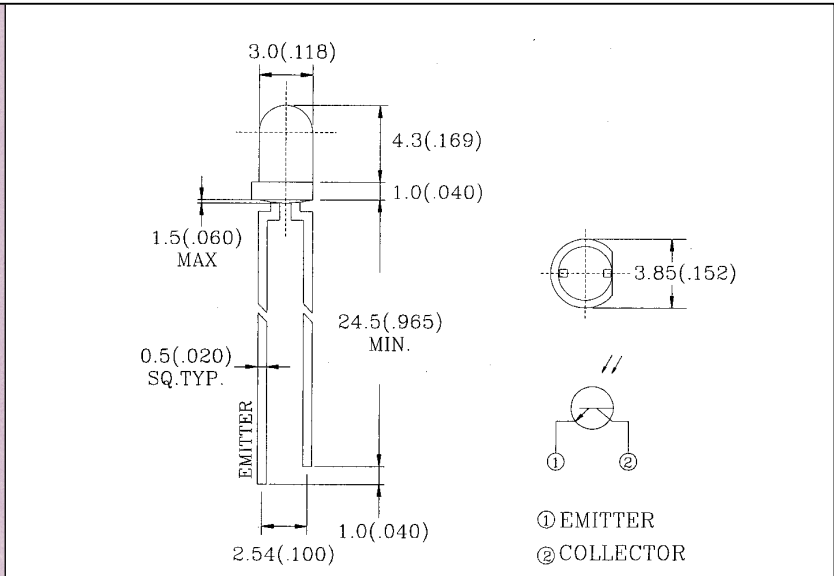

◆ **ABSOLUTE MAXIMUM RATING:(Ta=25°C)**

Part No.	P _D (mw)	V _{(BR)R} (V)	Topr	Tstg
L-31ROPT1XX	10	5	-35°C to 85°C	-35°C to 85°C
PARAMETER	Power Dissipation	Reverse break down voltage	Operating Temperature Range	Storage Temperature Range
Lead Soldering Temperature {1.6mm(0.063 inch)From Body}250°C ±5°C For 3 Seconds				

◆ **ELECTRO-OPTICAL CHARACTERISTICS:(Ta=25°C)**

Part No.	BV _{CEO} (V)			BV _{ECO} (V)			I _{CEO} (nA)			V _{CE(s)} (V)			t _r /t _f (uS)			I _c (mA)			C _{CB} (pF)			λ (nm)		
	MIN	TYP	MAX	MIN	TYP	MAX	MIN	TYP	MAX	MIN	TYP	MAX	MIN	TYP	MAX	MIN	TYP	MAX	MIN	TYP	MAX	MIN	PEAK	MAX
L-31ROPT1C	30			5					100			0.4	15	15		0.9	1.8				6.4	400		1050
L-31ROPT1D1	30			5					100			0.4	15	15		0.8	1.6				6.4	900	940	
L-31ROPT1D2	30			5					100			0.4	15	15		0.8	1.6				6.4	800	870	
TEST CONDITION	I _C =100uA E _e =0mW/cm ²			I _E =100uA E _e =0mW/cm ²			V _E =20V E _e =0mW/cm ²			I _C =2mA E _e =0.5mW/cm ²			V _{CE} =5V I _C =1mA R _L =1000Ω			V _{CE} =5V E _e =0.1mW/cm ²			f=1MHZ V _{CB} =3V E _e =0mW/cm ²					
PARAMETER	COLLECTOR-EMITTER BREAKDOWN VOLTAGE			EMITTER-COLLECTOR BREAKDOWN VOLTAGE			COLLECTOR DARK CURRENT			COLLECTOR-EMITTER SATURATION VOLTAGE			RISE/FALL TIME			ON STATE COLLECTOR CURRENT			COLLECTOR -BASE CAPACITANCE			SPECTRAL SENSITIVITY WAVELENGTH		

D1,D2=BLACK

1.All dimension are in millimeters (inches).

2.Tolerance is ± 0.25 mm (0.01") unless otherwise specified.

L-32XOPT1XX 3.0mm PHOTOTRANSISTOR

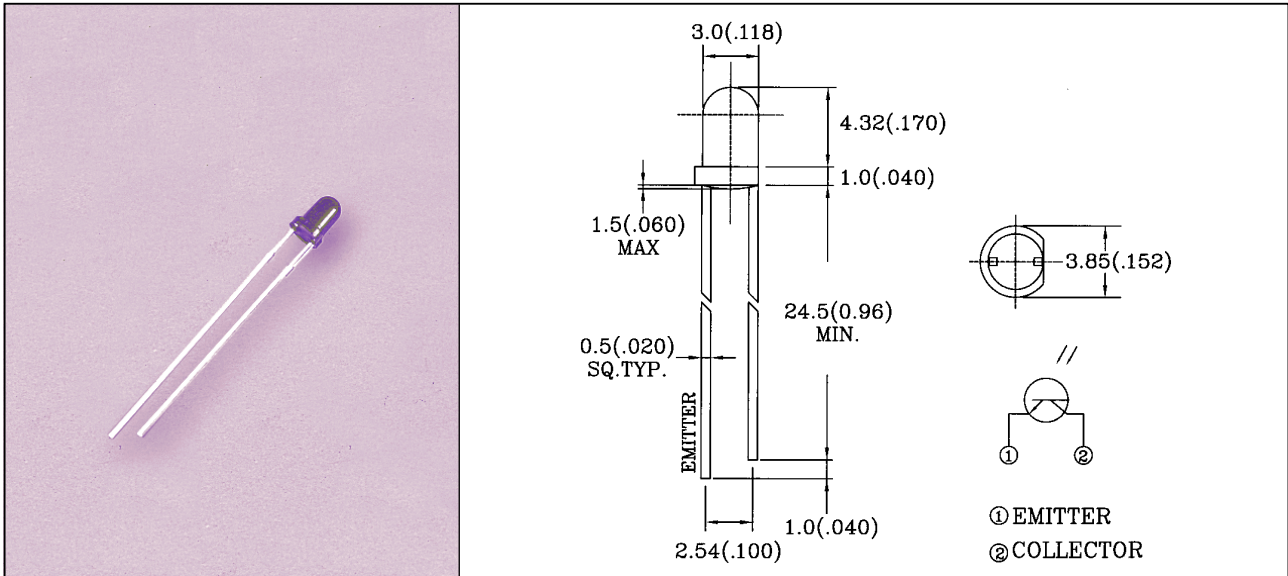

◆ **ABSOLUTE MAXIMUM RATING:(Ta=25°C)**

Part No.	P _D (mw)	V _{(BR)R} (V)	Topr	Tstg
L-32XOPT1XX	10	5	-35°C to 85°C	-35°C to 85°C
PARAMETER	Power Dissipation	Reverse Voltage	Operating Temperature Range	Storage Temperature Range
Lead Soldering Temperature {1.6mm(0.063 inch)From Body}250°C ±5°C For 3 Seconds				

◆ **ELECTRO-OPTICAL CHARACTERISTICS:(Ta=25°C)**

Part No.	BV _{CEO} (V)			BV _{ECO} (V)			I _{CEO} (nA)			V _{CE} (s)(V)			tr/t _f (uS)			I _c (mA)			Δλ (nm)		
	MIN	TYP	MAX	MIN	TYP	MAX	MIN	TYP	MAX	MIN	TYP	MAX	MIN	TYP	MAX	MIN	TYP	MAX	MIN	TYP	MAX
L-32ROPT1D1	30			5					100			0.4		15/15		0.2	0.6		900	940	
L-32AOPT1D1	30			5					100			0.4		15/15		0.6	1.0		900	940	
TEST CONDITION	I _C =100uA E _e =0mW/cm ²			I _E =100uA E _e =0mW/cm ²			V _E =20V E _e =0mW/cm ²			I _C =2mA E _e =0.5mW/cm ²			V _{CE} =5V I _C =1mA R _L =1000Ω			V _{CE} =5V E _e =0.1mW/cm ²					
PARAMETER	COLLECTOR-EMITTER BREAKDOWN VOLTAGE			EMITTER-COLLECTOR BREAKDOWN VOLTAGE			COLLECTOR DARK CURRENT			COLLECTOR-EMITTER SATURATION VOLTAGE			RISE/FALL TIME			ON STATE COLLECTOR CURRENT			SPECTRAL SENSITIVITY WAVELENGTH		

D1,D2=BLACK

1.All dimension are in millimeters(inches).

2.Tolerance is ±0.25mm(0.01")unless otherwise specified.

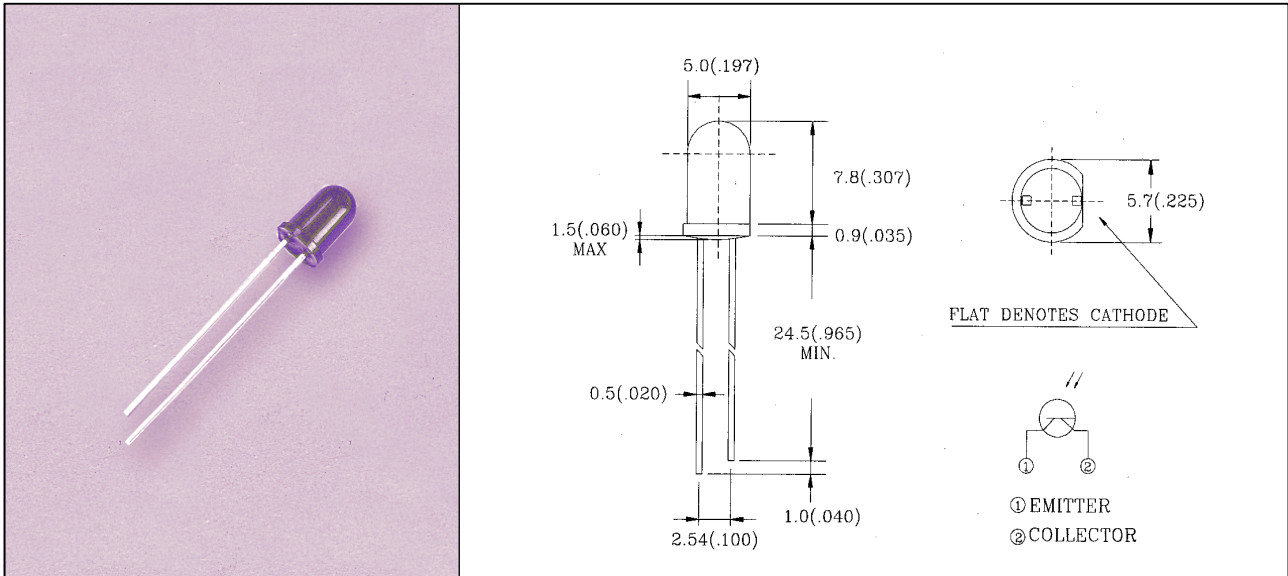

◆ **ABSOLUTE MAXIMUM RATING:(Ta=25°C)**

Part No.	P _D (mw)	V _{(BR)R} (V)	Topr	Tstg
L-51ROPT1XX	10	5	-35°C to 85°C	-35°C to 85°C
PARAMETER	Power Dissipation	Reverse break down voltage	Operating Temperature Range	Storage Temperature Range
Lead Soldering Temperature {1.6mm(0.063 inch)From Body}250°C ± 5°C For 3 Seconds				

◆ **ELECTRO-OPTICAL CHARACTERISTICS:(Ta=25°C)**

Part No.	BV _{CEO} (V)			BV _{ECO} (V)			I _{CEO} (nA)			V _{CE(s)} (V)			t _r /t _f (uS)			I _c (mA)			C _{CB} (pF)			λ (nm)			
	MIN	TYP	MAX	MIN	TYP	MAX	MIN	TYP	MAX	MIN	TYP	MAX	MIN	TYP	MAX	MIN	TYP	MAX	MIN	TYP	MAX	MIN	PEAK	MAX	
L-51ROPT1C	30			5					100			0.4	15	15		1.8	2.4				6.4			400	1050
L-51ROPT1D1	30			5					100			0.4	15	15		1.7	2.2				6.4			900	940
L-51ROPT1D2	30			5					100			0.4	15	15		1.7	2.2				6.4			800	870
TEST CONDITION	I _C =100uA E _e =0mW/cm ²			I _E =100uA E _e =0mW/cm ²			V _E =20V E _e =0mW/cm ²			I _C =2mA E _e =0.5mW/cm ²			V _{CE} =5V I _C =1mA R _L =1000Ω			V _{CE} =5V E _e =0.1mW/cm ²			f=1MHZ V _{CB} =3V E _e =0mW/cm ²						
PARAMETER	COLLECTOR-EMITTER BREAKDOWN VOLTAGE			EMITTER-COLLECTOR BREAKDOWN VOLTAGE			COLLECTOR DARK CURRENT			COLLECTOR-EMITTER SATURATION VOLTAGE			RISE/FALL TIME			ON STATE COLLECTOR CURRENT			COLLECTOR -BASE CAPACITANCE			SPECTRAL SENSITIVITY WAVELENGTH			

D1,D2=BLACK

1.All dimension are in millimeters (inches).

2.Tolerance is ± 0.25 mm (0.01") unless otherwise specified.



L-SB1R9PD1XX PHOTODIODE

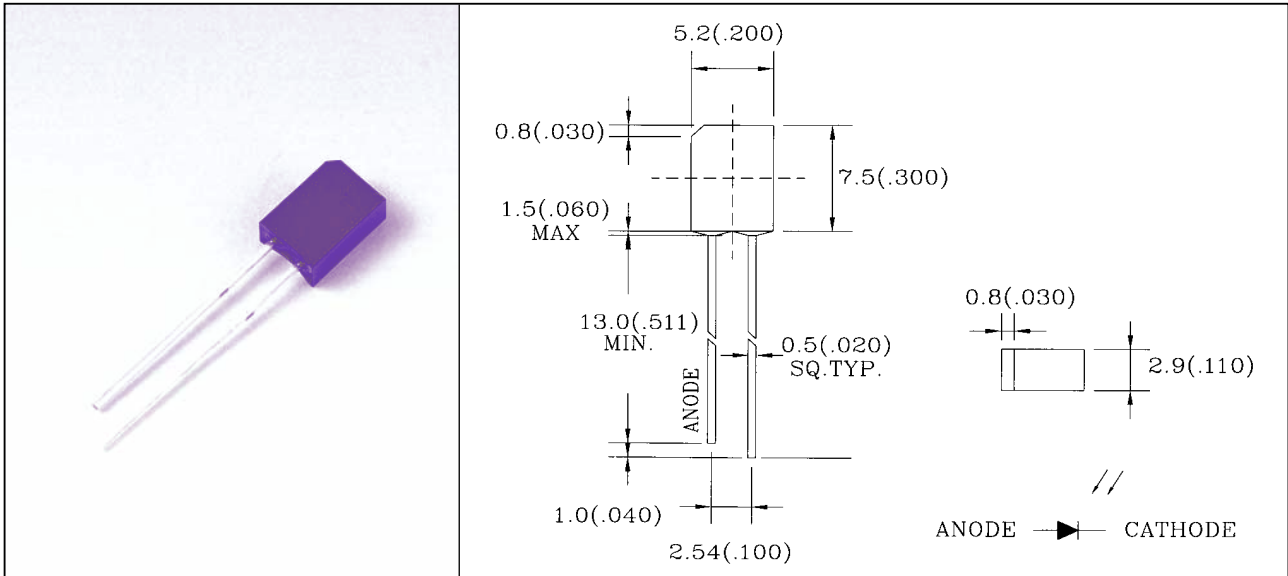

◆ABSOLUTE MAXIMUM RATING:(Ta=25°C)

Part No.	P _D (mw)	V _{(BR)R} (V)	Topr	Tstg
L-SB1R9PD1XX	0.1	30	-35°C to 85°C	-35°C to 85°C
PARAMETER	Power Dissipation	Reverse Voltage	Operating Temperature Range	Storage Temperature Range
Lead Soldering Temperature {1.6mm(0.063 inch)From Body}250°C ±5°C For 3 Seconds				

◆ELECTRO-OPTICAL CHARACTERISTICS:(Ta=25°C)

Part No.	I _D (nA)			V _{(BR)R} (V)			V _{OC} (mV)			I _L (uA)			ton/toff (nS)			C _T (pF)			λ (nm)		
	MIN	TYP	MAX	MIN	TYP	MAX	MIN	TYP	MAX	MIN	TYP	MAX	MIN	TYP	MAX	MIN	TYP	MAX	MIN	PEAK	MAX
L-SB1R9PD1C		5	30	33	170			390		30	40			45/45		18			400		1050
L-SB1R9PD1D1		5	30	33	170			390		30	40			45/45		18			900	940	
L-SB1R9PD1D2		5	30	33	170			390		30	40			45/45		18			800	870	
TEST CONDITION	V _R =10V Ee=0mW/cm ²			I _R =100uA Ee=0mW/cm ²			λ _c =940nm Ee=0.5mW/cm ²			V _R =5V Ee=0.1mW/cm ²			V _R =10V R _L =100Ω			f=1MHZ V _R =5V Ee=0mW/cm ²					
PARAMETER	REVERSE DARK CURRENT			REVERSE BREAKDOWN VOLTAGE			OPEN CIRCUIT VOLTAGE			LIGHT CURRENT			TURN-ON TURN-OFF TIME			TOTAL CAPACITANCE			SPECTRAL SENSITIVITY WAVELENGTH		

D1,D2=BLACK

1.All dimension are in millimeters (inches).

2.Tolerance is ± 0.25 mm (0.01") unless otherwise specified.

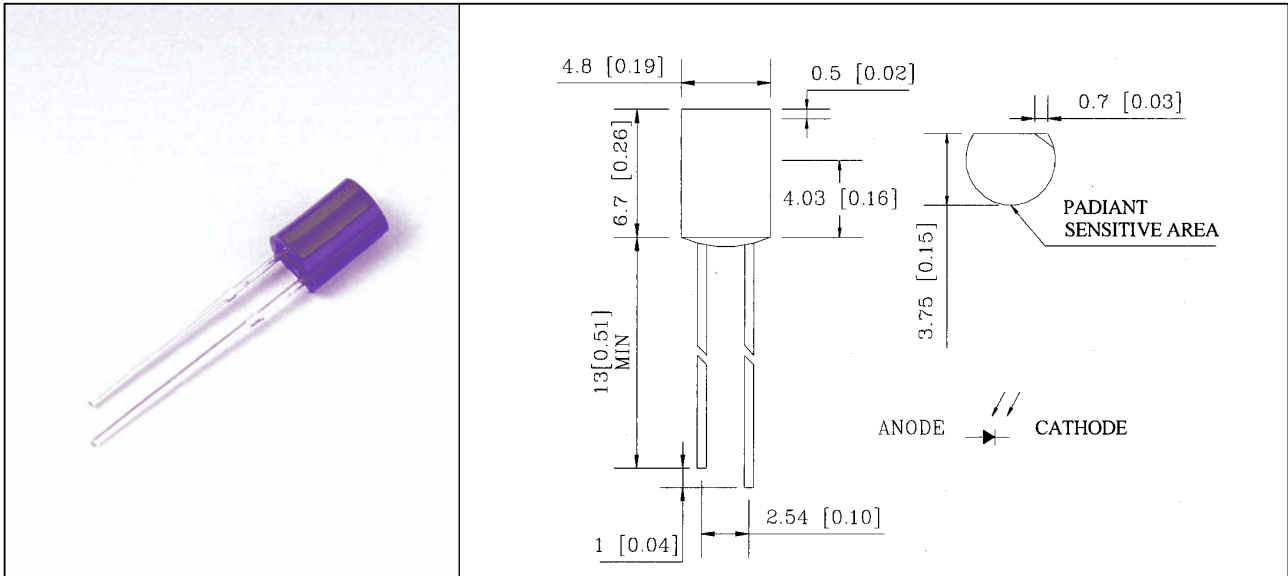

◆ **ABSOLUTE MAXIMUM RATING:(Ta=25°C)**

Part No.	P _D (mw)	V _{(BR)R} (V)	Topr	Tstg
L-SC1R9PD1XX	0.1	30	-35°C to 85°C	-35°C to 85°C
PARAMETER	Power Dissipation	Reverse Voltage	Operating Temperature Range	Storage Temperature Range
Lead Soldering Temperature {1.6mm(0.063 inch)From Body}250°C ±5°C For 3 Seconds				

◆ **ELECTRO-OPTICAL CHARACTERISTICS:(Ta=25°C)**

Part No.	I _D (nA)			V _{(BR)R} (V)			V _{OC} (mV)			I _L (uA)			t _{ON} /t _{OFF} (nS)			C _T (pF)			λ (nm)		
	MIN	TYP	MAX	MIN	TYP	MAX	MIN	TYP	MAX	MIN	TYP	MAX	MIN	TYP	MAX	MIN	TYP	MAX	MIN	PEAK	MAX
L-SC1R9PD1C		5	30	33	170			390		30	40			45/45		18		400		1050	
L-SC1R9PD1D1		5	30	33	170			390		30	40			45/45		18		900	940		
L-SC1R9PD1D2		5	30	33	170			390		30	40			45/45		18		800	870		
TEST CONDITION	V _R =10V E _e =0mW/cm ²			I _R =100uA E _e =0mW/cm ²			λ _c =940nm E _e =0.5mW/cm ²			V _R =5V E _e =0.1mW/cm ²			V _R =10V R _L =100Ω			f=1MHZ V _R =5V E _e =0mW/cm ²					
PARAMETER	REVERSE DARK CURRENT			REVERSE BREAKDOWN VOLTAGE			OPEN CIRCUIT VOLTAGE			LIGHT CURRENT			TURN-ON TURN-OFF TIME			TOTAL CAPACITANCE			SPECTRAL SENSITIVITY WAVELENGTH		

D1,D2=BLACK

1.All dimension are in millimeters (inches).

2.Tolerance is ± 0.25 mm (0.01") unless otherwise specified.

L-31XXIR1XX 3.0mm INFRARED EMITTING DIODE

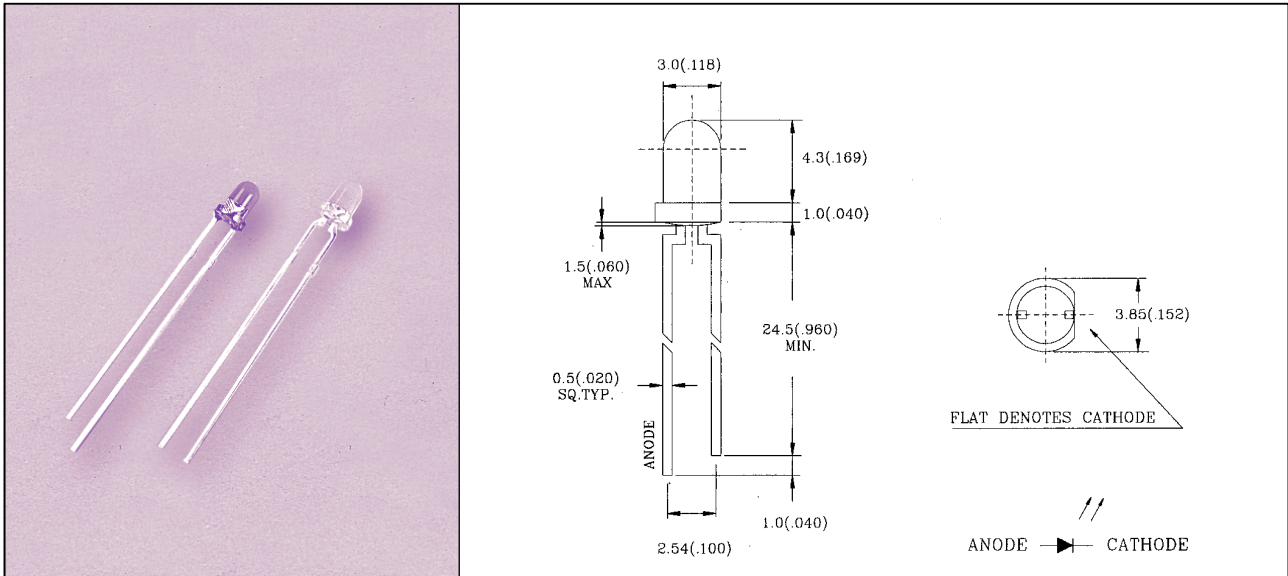

◆ **ABSOLUTE MAXIMUM RATING:(Ta=25°C)**

Part No.	P _D (mw)	V _R (V)	T _{opr}	T _{stg}
L-31XXIR1XX	100	5	-35°C to 85°C	-35°C to 85°C
PARAMETER	Power Dissipation	Reverse Voltage	Operating Temperature Range	Storage Temperature Range
Lead Soldering Temperature {1.6mm(0.063 inch)From Body}250°C ±5°C For 3 Seconds				

◆ **ELECTRO-OPTICAL CHARACTERISTICS:(Ta=25°C)**

Part No.	V _F (V)			I _R (μA)			λ _p (nm)			2 θ _{1/2} (dgc)			I _e (mw/sr)		
	MIN	TYP	MAX	MIN	TYP	MAX	MIN	TYP	MAX	MIN	TYP	MAX	MIN	TYP	MAX
L-314EIR1C		1.2 1.4	1.6			10		940			20		7	14	
L-315EIR1C		1.2 1.4	1.6			10		940			25		6	12	
L-316EIR1C		1.2 1.4	1.6			10		940			30		6	12	
L-314EIR1BC		1.2 1.4	1.6			10		940			20		5	10	
L-315EIR1BC		1.2 1.4	1.6			10		940			25		6	12	
L-316EIR1BC		1.2 1.4	1.6			10		940			30		6	12	
L-318EIR1BC		1.2 1.4	1.6			10		940			40		6	10	
TEST CONDITION	I _F =20mA I _F =100mA			V _R =5V			I _F =20mA			I _F =20mA			I _F =20mA		

BC=BLUE CLEAR

1.All dimension are in millimeters (inches).

2.Tolerance is ± 0.25 mm (0.01") unless otherwise specified.

L-32XXIRXX 3.0mm INFRARED EMITTING DIODE

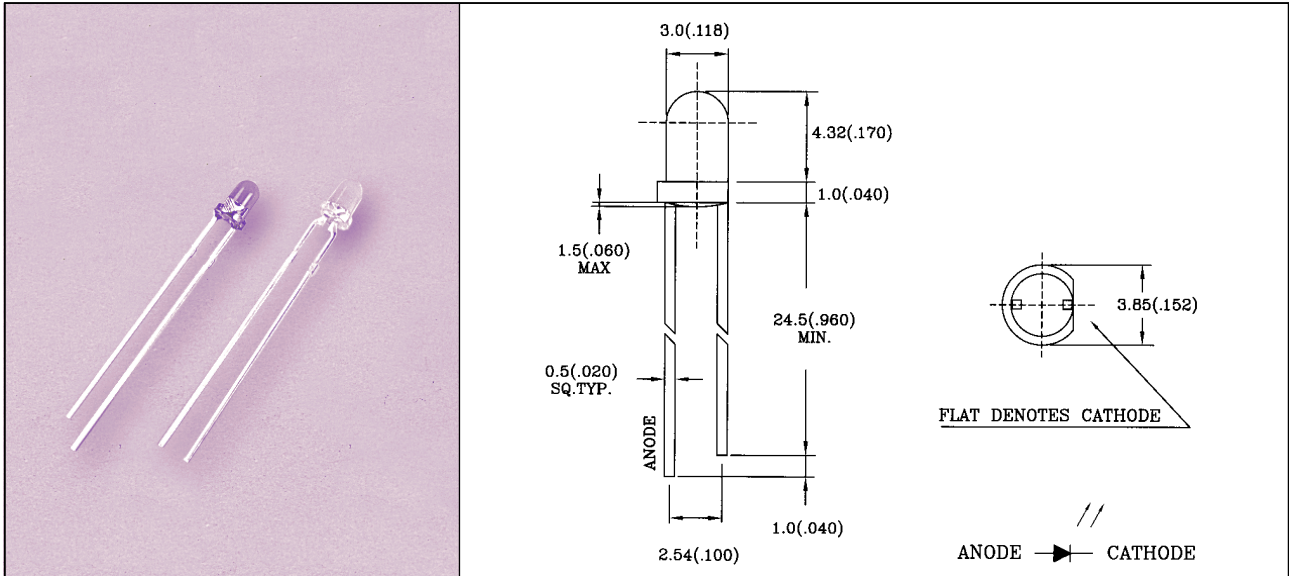

◆ **ABSOLUTE MAXIMUM RATING:(Ta=25°C)**

Part No.	P _D (mw)	V _R (V)	Topr	Tstg
L-32XXIRXX	100	5	-35°C to 85°C	-35°C to 85°C
PARAMETER	Power Dissipation	Reverse Voltage	Operating Temperature Range	Storage Temperature Range
Lead Soldering Temperature {1.6mm(0.063 inch)From Body}250°C ±5°C For 3 Seconds				

◆ **ELECTRO-OPTICAL CHARACTERISTICS:(Ta=25°C)**

Part No.	V _F (V)			I _R (μA)			λ _p (nm)			2 θ _{1/2} (dgr)			I _e (mw/sr)		
	MIN	TYP	MAX	MIN	TYP	MAX	MIN	TYP	MAX	MIN	TYP	MAX	MIN	TYP	MAX
L-327EIR1C	-	1.2	1.6	-	-	10	-	940	-		35		7.5	15	-
L-327EIR1BC	-	1.2	1.6	-	-	10	-	940	-		35		7.5	15	-
L-32AEIR1C	-	1.2	1.6	-	-	10	-	940	-		50		6	10	-
TEST CONDITION	I _F =20mA I _F =100mA			V _R =5V			I _F =20mA			I _F =20mA			I _F =20mA		

BC=BLUE CLEAR

- 1.All dimension are in millimeters (inches).
- 2.Tolerance is ± 0.25 mm (0.01") unless otherwise specified.

L-51XXIR1C 5.0mm INFRARED EMITTING DIODE

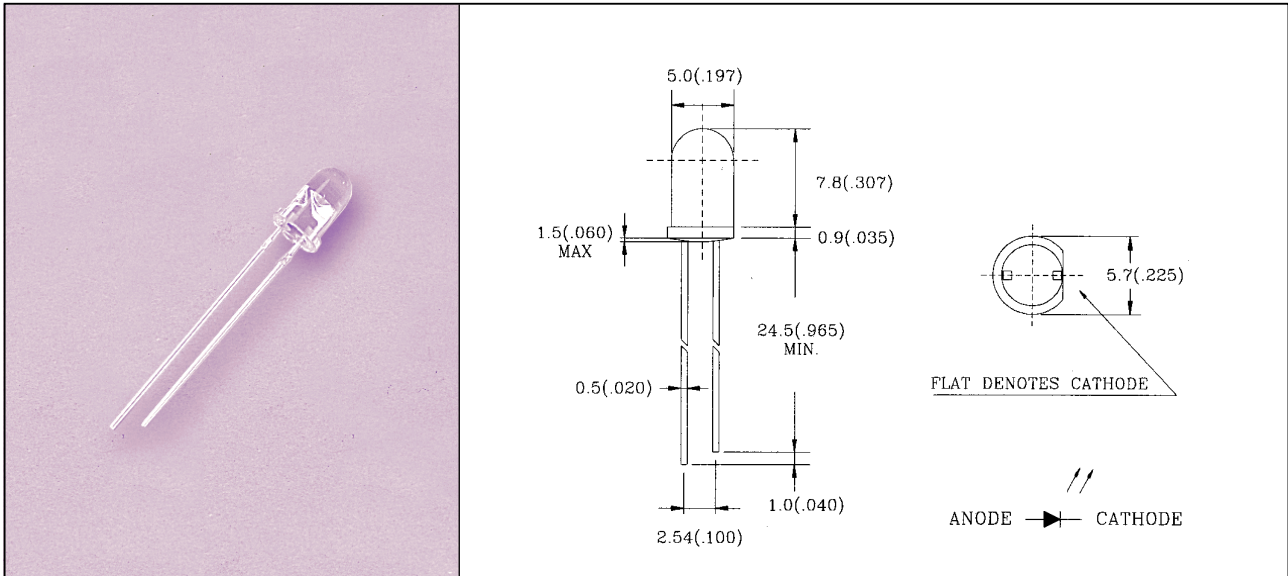

◆ **ABSOLUTE MAXIMUM RATING:(Ta=25°C)**

Part No.	P _D (mw)	V _R (V)	T _{opr}	T _{stg}
L-51XXIR1C	100	5	-35°C to 85°C	-35°C to 85°C
PARAMETER	Power Dissipation	Reverse Voltage	Operating Temperature Range	Storage Temperature Range
Lead Soldering Temperature {1.6mm(0.063 inch)From Body}250°C ±5°C For 3 Seconds				

◆ **ELECTRO-OPTICAL CHARACTERISTICS:(Ta=25°C)**

Part No.	V _F (V)			I _R (μA)			λ _p (nm)			2 θ _{1/2} (dgc)			I _e (mw/sr)		
	MIN	TYP	MAX	MIN	TYP	MAX	MIN	TYP	MAX	MIN	TYP	MAX	MIN	TYP	MAX
L-514EIR1C		1.2 1.4	1.6			10		940			20		17	30	
L-515EIR1C		1.2 1.4	1.6			10		940			25		14	25	
L-516EIR1C		1.2 1.4	1.6			10		940			30		12	23	
L-517EIR1C		1.2 1.4	1.6			10		940			35		10	20	
L-518EIR1C		1.2 1.4	1.6			10		940			40		8	18	
L-51AEIR1C		1.2 1.4	1.6			10		940			50		6	12	
L-514CIR1C		1.3 1.6	1.8			10		940			20		13	25	
TEST CONDITION	I _F =20mA I _F =100mA			V _R =5V			I _F =20mA			I _F =20mA			I _F =20mA		

- 1.All dimension are in millimeters (inches).
- 2.Tolerance is ± 0.25 mm (0.01") unless otherwise specified.

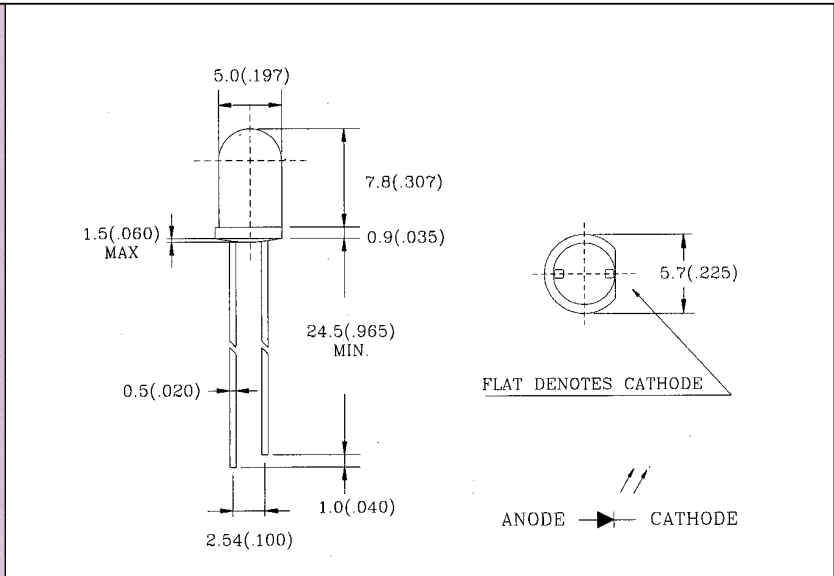

◆ **ABSOLUTE MAXIMUM RATING:(Ta=25°C)**

Part No.	P _D (mw)	V _R (V)	Topr	Tstg
L-51XXIR1BC	100	5	-35°C to 85°C	-35°C to 85°C
PARAMETER	Power Dissipation	Reverse Voltage	Operating Temperature Range	Storage Temperature Range
Lead Soldering Temperature {1.6mm(0.063 inch)From Body}250°C ±5°C For 3 Seconds				

◆ **ELECTRO-OPTICAL CHARACTERISTICS:(Ta=25°C)**

Part No.	V _F (V)			I _R (μA)			λ _p (nm)			2 θ1/2 (dgc)			I _e (mw/sr)		
	MIN	TYP	MAX	MIN	TYP	MAX	MIN	TYP	MAX	MIN	TYP	MAX	MIN	TYP	MAX
L-514EIR1BC		1.2 1.4	1.6			10		940			20		17	30	
L-515EIR1BC		1.2 1.4	1.6			10		940			25		14	25	
L-516EIR1BC		1.2 1.4	1.6			10		940			30		12	23	
L-517EIR1BC		1.2 1.4	1.6			10		940			35		10	20	
L-518EIR1BC		1.2 1.4	1.6			10		940			40		8	18	
L-51AEIR1BC		1.2 1.4	1.6			10		940			50		6	12	
L-514CIR1BC		1.3 1.6	1.8			10		940			20		13	25	
TEST CONDITION	I _F =20mA I _F =100mA			V _R =5V			I _F =20mA			I _F =20mA			I _F =20mA		

BC=BLUE CLEAR

1.All dimension are in millimeters (inches).

2.Tolerance is ± 0.25 mm (0.01") unless otherwise specified.