

## Half bridge gate driver

Datasheet - production data

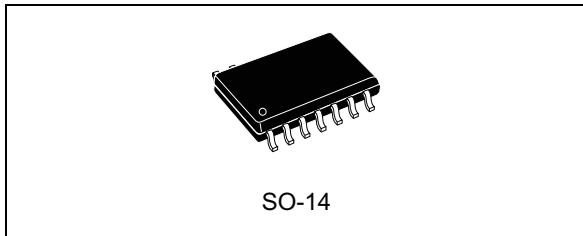

### Features

- High voltage rail up to 600 V
- $dV/dt$  immunity  $\pm 50$  V/nsec in full temperature range
- Driver current capability:
  - 290 mA source,
  - 430 mA sink
- Switching times 75/35 nsec rise/fall with 1 nF load
- 3.3 V, 5 V CMOS/TTL input comparators with hysteresis
- Integrated bootstrap diode
- Uncommitted comparator
- Adjustable deadtime
- Compact and simplified layout
- Bill of material reduction
- Flexible, easy and fast design

### Application

- Motor driver for home appliances
- Factory automation
- Industrial drives and fans
- HID ballasts
- Power supply units

### Description

The L6393 is a high voltage device manufactured with the BCD™ “offline” technology. It is a single chip half bridge gate driver for the N-channel power MOSFET or IGBT.

The high-side (floating) section is designed to stand a voltage rail up to 600 V.

The logic inputs are CMOS/TTL compatible down to 3.3 V for the easy interfacing microcontroller/DSP.

The IC embeds an uncommitted comparator available for protections against overcurrent, overtemperature, etc.

# Contents

<b>1</b>	<b>Block diagram</b> .....	<b>3</b>
<b>2</b>	<b>Pin connection</b> .....	<b>4</b>
<b>3</b>	<b>Truth table</b> .....	<b>5</b>
<b>4</b>	<b>Electrical data</b> .....	<b>6</b>
	4.1 Absolute maximum ratings .....	6
	4.2 Thermal data .....	6
	4.3 Recommended operating conditions .....	7
<b>5</b>	<b>Electrical characteristics</b> .....	<b>8</b>
	5.1 AC operation .....	8
	5.2 DC operation .....	10
<b>6</b>	<b>Waveform definition</b> .....	<b>12</b>
<b>7</b>	<b>Typical application diagram</b> .....	<b>13</b>
<b>8</b>	<b>Bootstrap driver</b> .....	<b>14</b>
	C <sub>BOOT</sub> selection and charging .....	14
<b>9</b>	<b>Package information</b> .....	<b>16</b>
	SO-14 package information .....	16
<b>10</b>	<b>Order codes</b> .....	<b>18</b>
<b>11</b>	<b>Revision history</b> .....	<b>18</b>

# 1 Block diagram

Figure 1. Block diagram

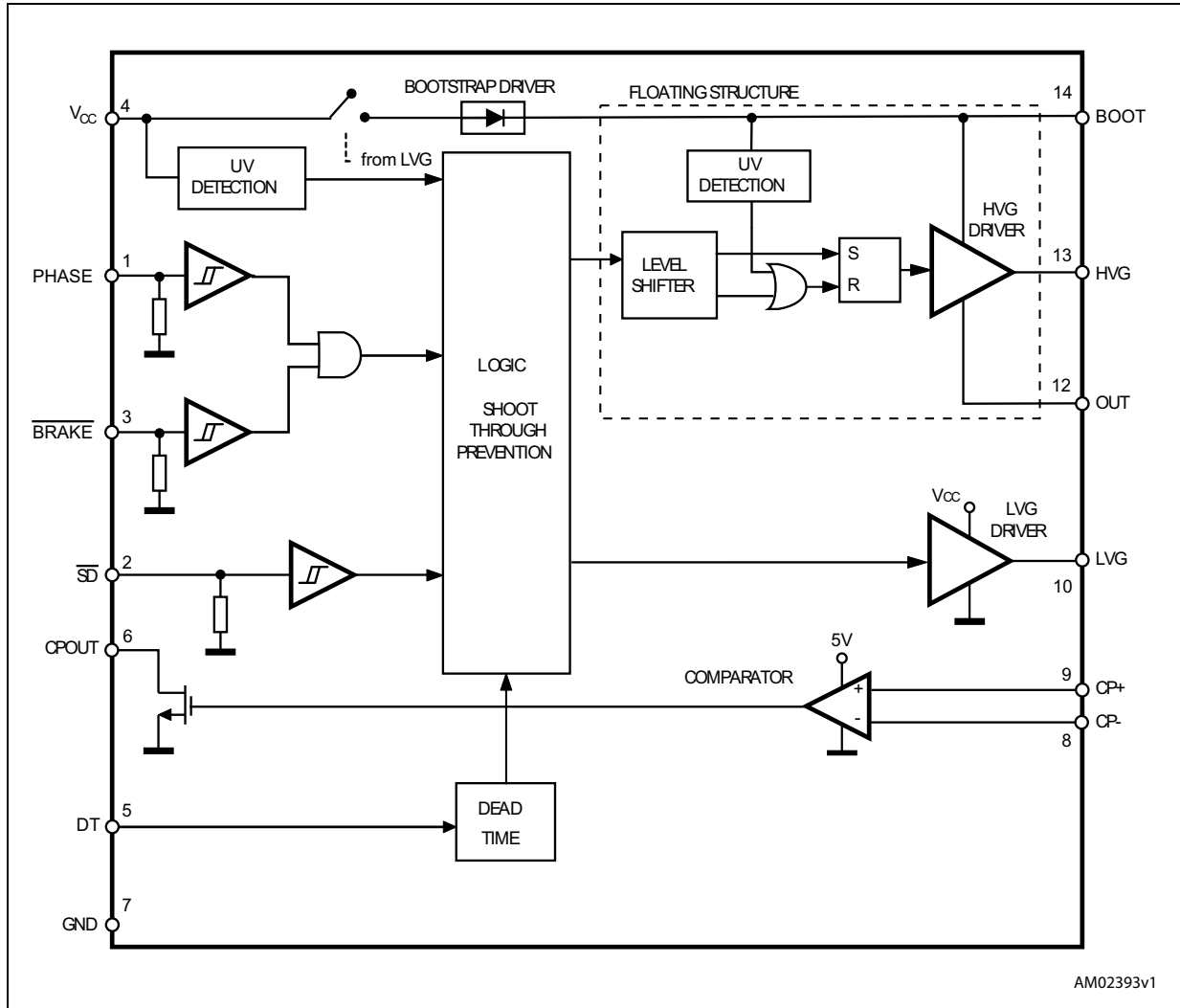

## 2 Pin connection

Figure 2. Pin connection (top view)

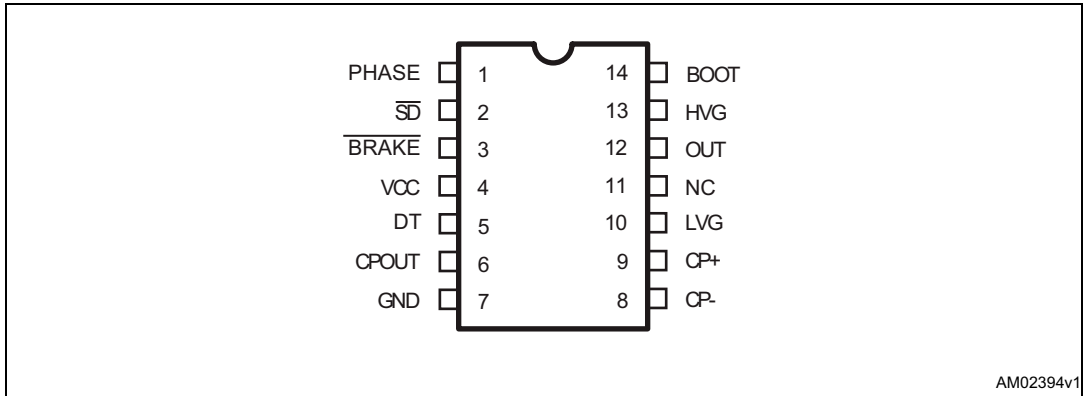

Table 1. Pin description

Pin no.	Pin name	Type	Function
1	PHASE	I	Driver logic input (active high)
2	$\overline{SD}^{(1)}$	I	Shutdown input (active low)
3	$\overline{BRAKE}$	I	Driver logic input (active low)
4	VCC	P	Lower section supply voltage
5	DT	I	Deadtime setting
6	CPOUT	O	Comparator output (open drain)
7	GND	P	Ground
8	CP-	I	Comparator negative input
9	CP+	I	Comparator positive input
10	LVG <sup>(1)</sup>	O	Low-side driver output
11	NC		Not connected
12	OUT	P	High-side (floating) common voltage
13	HVG <sup>(1)</sup>	O	High-side driver output
14	BOOT	P	Bootstrapped supply voltage

1. The circuit provides less than 1 V on the LVG and HVG pins (at  $I_{sink} = 10 \text{ mA}$ ), with  $V_{CC} > 3 \text{ V}$ . This allows omitting the “bleeder” resistor connected between the gate and the source of the external MOSFET normally used to hold the pin low; the gate driver assures low impedance also in SD condition.

### 3 Truth table

Table 2. Truth table

Inputs			Outputs	
$\overline{\text{SD}}$	PHASE	$\overline{\text{BRAKE}}$	LVG	HVG
L	X <sup>(1)</sup>	X <sup>(1)</sup>	L	L
H	L	L	H	L
H	L	H	H	L
H	H	L	H	L
H	H	H	L	H

1. X: don't care.

In the L6393 IC the two input signals PHASE and  $\overline{\text{BRAKE}}$  are fed into an AND logic port and the resulting signal is in phase with the high-side output HVG and in opposition of phase with the low-side output LVG. This means that if  $\overline{\text{BRAKE}}$  is kept to a high level, the PHASE signal drives the half bridge in phase with the HVG output and in opposition of phase with the LVG output. If  $\overline{\text{BRAKE}}$  is set to a low level, the low-side output LVG is always ON and the high-side output HVG is always OFF, whatever the PHASE signal. This kind of logic interface provides the possibility to control the power stages using the PHASE signal to select the current direction in the bridge and the BRAKE signal to perform current slow decay on the low-sides.

From the point of view of the logic operations the two signals PHASE and  $\overline{\text{BRAKE}}$  are completely equivalent, that means the two signals can be exchanged without any change in the behavior on the resulting output signals (see [Figure 1](#)).

*Note:* The deadtime between the turn-OFF of one power switch and the turn-ON of the other power switch is defined by the resistor connected between the DT pin and the ground.

## 4 Electrical data

### 4.1 Absolute maximum ratings

Table 3. Absolute maximum ratings

Symbol	Parameter	Value		Unit
		Min.	Max.	
$V_{CC}$	Supply voltage	-0.3	21	V
$V_{OUT}$	Output voltage	$V_{BOOT} - 21$	$V_{BOOT} + 0.3$	V
$V_{BOOT}$	Bootstrap voltage	-0.3	620	V
$V_{hvg}$	High-side gate output voltage	$V_{OUT} - 0.3$	$V_{BOOT} + 0.3$	V
$V_{lvg}$	Low-side gate output voltage	-0.3	$V_{CC} + 0.3$	V
$V_{CP+}$	Comparator positive input voltage	-0.3	$V_{CC} + 0.3$	V
$V_{CP-}$	Comparator negative input voltage	-0.3	$V_{CC} + 0.3$	V
$V_i$	Logic input voltage	-0.3	15	V
$V_{od}$	Open drain voltage	-0.3	15	V
$dV_{OUT}/dt$	Allowed output slew rate		50	V/ns
$P_{tot}$	Total power dissipation ( $T_A = 25\text{ °C}$ )		800	mW
$T_J$	Junction temperature		150	°C
$T_{STG}$	Storage temperature	-50	150	°C
ESD	Human body model	2		kV

### 4.2 Thermal data

Table 4. Thermal data

Symbol	Parameter	SO-14	Unit
$R_{th(JA)}$	Thermal resistance junction to ambient max.	120	°C/W

### 4.3 Recommended operating conditions

Table 5. Recommended operating conditions

Symbol	Pin	Parameter	Test condition	Min.	Max.	Unit
$V_{CC}$	4	Supply voltage		10	20	V
$V_{BO}^{(1)}$	14 - 12	Floating supply voltage		9.8	20	V
$V_{OUT}$	12	DC output voltage		- 9 <sup>(2)</sup>	580	V
$V_{CP-}$	8	Comparator negative input voltage	$V_{CP+} \leq 2.5\text{ V}$		$V_{CC}^{(3)}$	V
$V_{CP+}$	9	Comparator positive input voltage	$V_{CP-} \leq 2.5\text{ V}$		$V_{CC}^{(3)}$	V
$f_{sw}$		Switching frequency	HVG, LVG load $C_L = 1\text{ nF}$		800	kHz
$T_J$		Junction temperature		-40	125	°C

1.  $V_{BO} = V_{BOOT} - V_{OUT}$

2. LVG off.  $V_{CC} = 10\text{ V}$ . Logic is operational if  $V_{BOOT} > 5\text{ V}$ , refer to AN2785 for more details.

3. At least one of the comparator's input must be lower than 2.5 V to guarantee proper operation.

## 5 Electrical characteristics

### 5.1 AC operation

Table 6. AC operation electrical characteristics ( $V_{CC} = 15\text{ V}$ ,  $T_J = +25\text{ °C}$ )

Symbol	Pin	Parameter	Test condition	Min.	Typ.	Max.	Unit
<b>AC operation</b>							
$t_{on}$	1, 3 vs. 10, 13	High/low-side driver turn-on propagation delay	$V_{OUT} = 0\text{ V}$ $V_{BOOT} = V_{CC}$ $C_L = 1\text{ nF}$ $V_i = 0\text{ to }3.3\text{ V}$ see <a href="#">Figure 3</a>	50	125	200	ns
$t_{off}$		High/low-side driver turn-off propagation delay		50	125	200	ns
$t_{sd}$	2 vs. 10, 13	Shutdown to high/low-side propagation delay		50	125	200	ns
MT		Delay matching, HS and LS turn-on/off				30	ns
DT	5	Deadtime setting range <sup>(1)</sup>	$R_{DT} = 0, C_L = 1\text{ nF}$	0.1	0.18	0.25	$\mu\text{s}$
			$R_{DT} = 37\text{ k}\Omega, C_L = 1\text{ nF}, C_{DT} = 100\text{ nF}$	0.48	0.6	0.72	
			$R_{DT} = 136\text{ k}\Omega, C_L = 1\text{ nF}, C_{DT} = 100\text{ nF}$	1.35	1.6	1.85	
			$R_{DT} = 260\text{ k}\Omega, C_L = 1\text{ nF}, C_{DT} = 100\text{ nF}$	2.6	3.0	3.4	
MDT		Matching deadtime <sup>(2)</sup>	$R_{DT} = 0\ \Omega; C_L = 1\text{ nF}$			80	ns
			$R_{DT} = 37\text{ k}\Omega; C_L = 1\text{ nF}; C_{DT} = 100\text{ nF}$			120	
			$R_{DT} = 136\text{ k}\Omega; C_L = 1\text{ nF}; C_{DT} = 100\text{ nF}$			250	
			$R_{DT} = 260\text{ k}\Omega; C_L = 1\text{ nF}; C_{DT} = 100\text{ nF}$			400	
$t_r$	10, 13	Rise time	$C_L = 1\text{ nF}$		75	120	ns
$t_f$		Fall time	$C_L = 1\text{ nF}$		35	70	ns

1. See [Figure 4](#).

2.  $MDT = |DT_{LH} - DT_{HL}|$  see [Figure 5 on page 12](#).



Figure 3. Timing

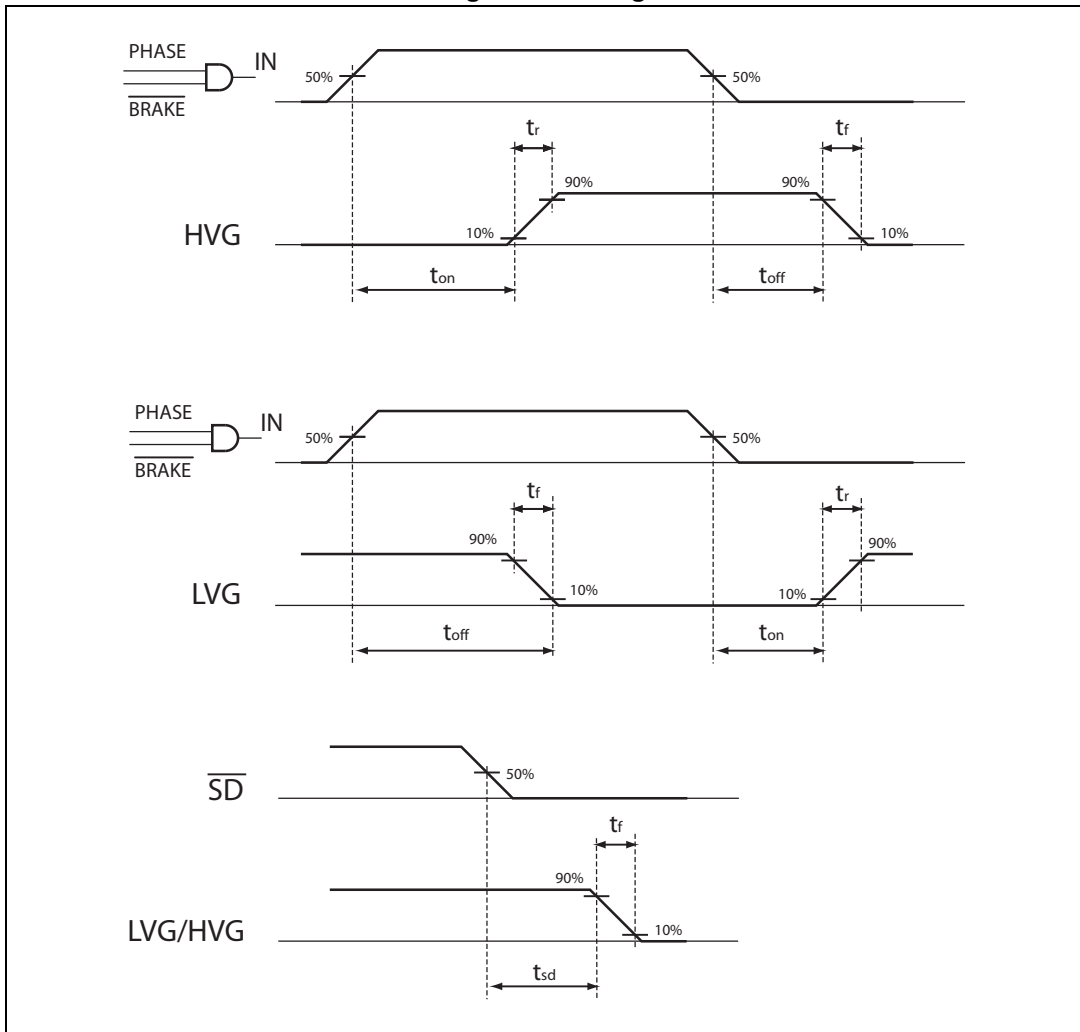
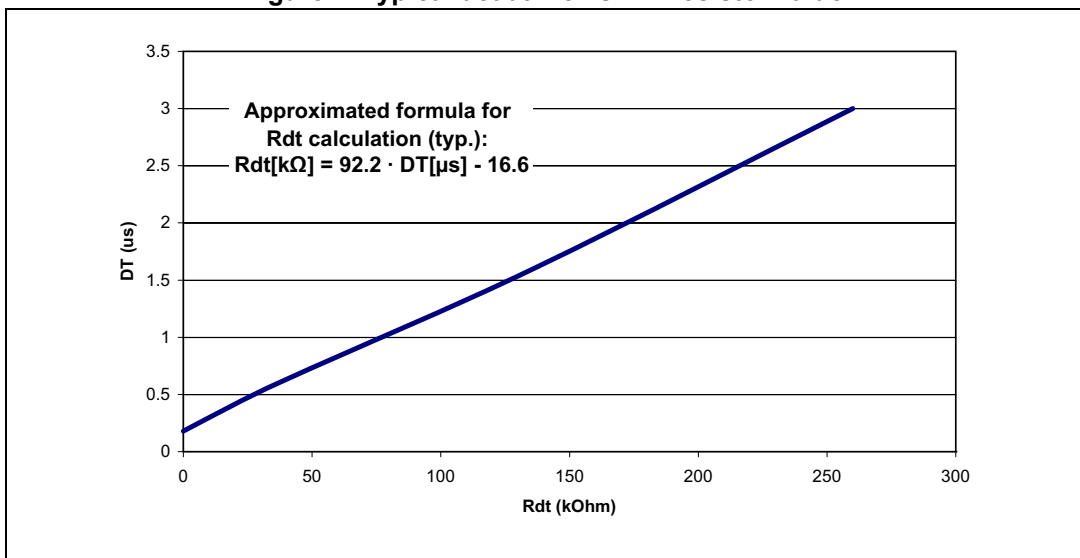

Figure 4. Typical deadtime vs. DT resistor value



## 5.2 DC operation

Table 7. DC operation electrical characteristics ( $V_{CC} = 15\text{ V}$ ;  $T_J = +25\text{ °C}$ )

Symbol	Pin	Parameter	Test condition	Min.	Typ.	Max.	Unit	
<b>Low supply voltage section</b>								
$V_{CC\_hys}$	4	$V_{CC}$ UV hysteresis		1.2	1.5	1.8	V	
$V_{CC\_thON}$		$V_{CC}$ UV turn-ON threshold		9	9.5	10	V	
$V_{CC\_thOFF}$		$V_{CC}$ UV turn-OFF threshold		7.6	8	8.4		
$I_{QCCU}$		Undervoltage quiescent supply current	$V_{CC} = 7\text{ V}$ ; $\overline{SD} = 5\text{ V}$ ; PHASE and BRAKE = GND; $R_{DT} = 0\ \Omega$ ; CP + = GND; CP - = 0.5 V			110	150	$\mu\text{A}$
$I_{QCC}$	Quiescent current	$V_{CC} = 15\text{ V}$ ; $\overline{SD} = 5\text{ V}$ ; PHASE and BRAKE = GND; $R_{DT} = 0\ \Omega$ ; CP + = GND; CP - = 0.5 V			600	1000		
<b>Bootstrapped supply voltage section<sup>(1)</sup></b>								
$V_{BO\_hys}$	14	$V_{BO}$ UV hysteresis		0.8	1.0	1.2	V	
$V_{BO\_thON}$		$V_{BO}$ UV turn-ON threshold		8.2	9	9.8	V	
$V_{BO\_thOFF}$		$V_{BO}$ UV turn-OFF threshold		7.3	8	8.7	V	
$I_{QBOU}$	14	Undervoltage $V_{BOOT}$ quiescent current	$V_{BO} = 7\text{ V}$ ; $\overline{SD} = 5\text{ V}$ ; PHASE and BRAKE = 5 V; $R_{DT} = 0\ \Omega$ ; CP + = GND; CP - = 0.5 V			40	100	$\mu\text{A}$
$I_{QBO}$		$V_{BOOT}$ quiescent current	$V_{BO} = 15\text{ V}$ ; $\overline{SD} = 5\text{ V}$ ; PHASE and BRAKE = 5 V; $R_{DT} = 0\ \Omega$ ; CP + = GND; CP - = 0.5 V			140	210	
$I_{LK}$		High voltage leakage current	$V_{hvg} = V_{OUT} = V_{BOOT} = 600\text{ V}$			10		
$R_{Dson}$		Bootstrap driver on resistance <sup>(2)</sup>	LVG ON		120		$\Omega$	
<b>Driving buffers section</b>								
$I_{so}$	10, 13	High/low-side source short-circuit current	$V_{IN} = V_{ih}$ ( $t_p < 10\ \mu\text{s}$ )	200	290		mA	
$I_{si}$		High/low-side sink short-circuit current	$V_{IN} = V_{il}$ ( $t_p < 10\ \mu\text{s}$ )	250	430		mA	
<b>Logic inputs</b>								
$V_{il}$	1, 2, 3	Low level logic threshold voltage		0.8		1.1	V	
$V_{ih}$		High level logic threshold voltage		1.9		2.25	V	

Table 7. DC operation electrical characteristics ( $V_{CC} = 15\text{ V}$ ;  $T_J = +25\text{ °C}$ ) (continued)

Symbol	Pin	Parameter	Test condition	Min.	Typ.	Max.	Unit
$I_{PHASEh}$	1	PHASE logic "1" input bias current	PHASE = 15 V	20	40	100	$\mu\text{A}$
$I_{PHASEl}$		PHASE logic "0" input bias current	PHASE = 0 V			1	
$I_{BRAKEh}$	3	$\overline{\text{BRAKE}}$ logic "1" input bias current	$\overline{\text{BRAKE}} = 15\text{ V}$	20	40	100	
$I_{BRAKEl}$		$\overline{\text{BRAKE}}$ logic "0" input bias current	$\overline{\text{BRAKE}} = 0\text{ V}$			1	
$I_{SDh}$	2	$\overline{\text{SD}}$ logic "1" input bias current	$\overline{\text{SD}} = 15\text{ V}$	10	30	100	
$I_{SDl}$		$\overline{\text{SD}}$ logic "0" input bias current	$\overline{\text{SD}} = 0\text{ V}$			1	

1.  $V_{BO} = V_{BOOT} - V_{OUT}$ .

2.  $R_{DSon}$  is tested in the following way:

$$R_{DSon} = \frac{(V_{CC} - V_{BOOT1}) - (V_{CC} - V_{BOOT2})}{[I_1(V_{CC}, V_{BOOT1}) - I_2(V_{CC}, V_{BOOT2})]}$$

where  $I_1$  is the pin 14 current when  $V_{BOOT} = V_{BOOT1}$ ,  $I_2$  when  $V_{BOOT} = V_{BOOT2}$ .

Table 8. Sense comparator ( $V_{CC} = 15\text{ V}$ ,  $T_J = +25\text{ °C}$ )(<sup>1</sup>)

Symbol	Pin	Parameter	Test conditions	Min.	Typ.	Max.	Unit
$V_{io}$	8, 9	Input offset voltage		-15		15	mV
$I_{ib}$		Input bias current	$V_{CP+} = 1\text{ V}$			1	$\mu\text{A}$
$V_{ol}$	6	Open drain low level output voltage	$I_{od} = -3\text{ mA}$			0.5	V
$t_{d\_comp}$		Comparator delay	$R_{pu} = 100\text{ k}\Omega$ to 5 V; $V_{CP-} = 0.5\text{ V}$		90	130	ns
SR	6	Slew rate	$C_L = 180\text{ pF}$ , $R_{pu} = 5\text{ k}\Omega$		60		V/ $\mu\text{s}$

1. The comparator is disabled when  $V_{CC}$  is in UVLO condition.

## 6 Waveform definition

Figure 5. Deadtime waveform definition

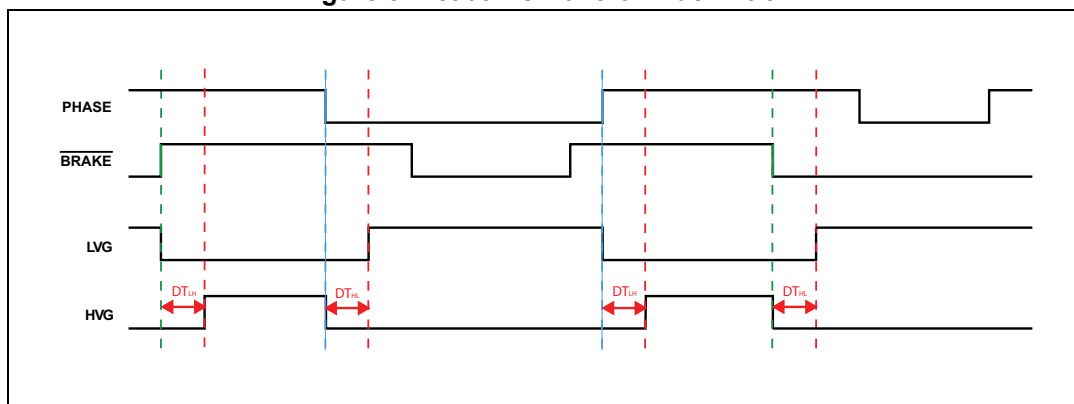

# 7 Typical application diagram

Figure 6. Application diagram

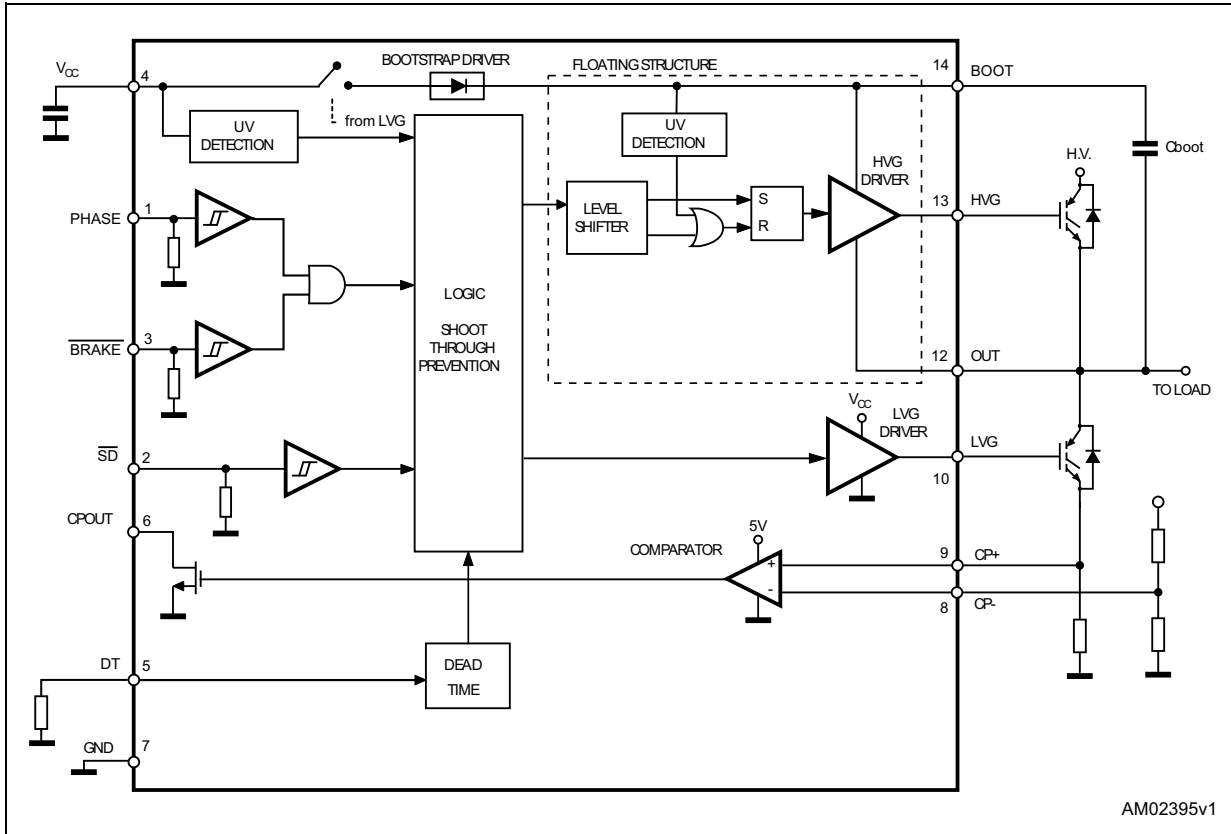

## 8 Bootstrap driver

A bootstrap circuitry is needed to supply the high voltage section. This function is normally accomplished by a high voltage fast recovery diode (*Figure 7.a*). In the L6393 device a patented integrated structure replaces the external diode. It is realized by a high voltage DMOS, driven synchronously with the low-side driver (LVG), with a diode in series, as shown in *Figure 7.b*. An internal charge pump (*Figure 7.b*) provides the DMOS driving voltage.

### $C_{BOOT}$ selection and charging

To choose the proper  $C_{BOOT}$  value the external MOSFET can be seen as an equivalent capacitor. This capacitor  $C_{EXT}$  is related to the MOSFET total gate charge:

#### Equation 1

$$C_{EXT} = \frac{Q_{gate}}{V_{gate}}$$

The ratio between the capacitors  $C_{EXT}$  and  $C_{BOOT}$  is proportional to the cyclical voltage loss. It has to be:

$$C_{BOOT} \gg C_{EXT}$$

E.g.: if  $Q_{gate}$  is 30 nC and  $V_{gate}$  is 10 V,  $C_{EXT}$  is 3 nF. With  $C_{BOOT} = 100$  nF the drop would be 300 mV.

If HVG has to be supplied for a long time, the  $C_{BOOT}$  selection has to take into account also the leakage and quiescent losses.

E.g.: HVG steady state consumption is lower than 200  $\mu$ A, so if HVG  $T_{ON}$  is 5 ms,  $C_{BOOT}$  has to supply 1  $\mu$ C to  $C_{EXT}$ . This charge on a 1  $\mu$ F capacitor means a voltage drop of 1 V.

The internal bootstrap driver gives a great advantage: the external fast recovery diode can be avoided (it usually has a great leakage current).

This structure can work only if  $V_{OUT}$  is close to GND (or lower) and in the meanwhile the LVG is on. The charging time ( $T_{charge}$ ) of the  $C_{BOOT}$  is the time in which both conditions are fulfilled and it has to be long enough to charge the capacitor.

The bootstrap driver introduces a voltage drop due to the DMOS  $R_{DSon}$  (typical value: 120  $\Omega$ ). At low frequency this drop can be neglected. Anyway increasing the frequency it must be taken in to account.

The following equation is useful to compute the drop on the bootstrap DMOS:

#### Equation 2

$$V_{drop} = I_{charge} R_{dson} \rightarrow V_{drop} = \frac{Q_{gate}}{T_{charge}} R_{dson}$$

where  $Q_{gate}$  is the gate charge of the external power MOSFET,  $R_{DSon}$  is the on resistance of the bootstrap DMOS, and  $T_{charge}$  is the charging time of the bootstrap capacitor.

For example: using a power MOSFET with a total gate charge of 30 nC the drop on the bootstrap DMOS is about 1 V, if the  $T_{charge}$  is 5  $\mu s$ . In fact:

**Equation 3**

$$V_{drop} = \frac{30nC}{5\mu S} \cdot 120\Omega \sim 0.7V$$

$V_{drop}$  has to be taken into account when the voltage drop on  $C_{BOOT}$  is calculated: if this drop is too high, or the circuit topology doesn't allow a sufficient charging time, an external diode can be used.

**Figure 7. Bootstrap driver**

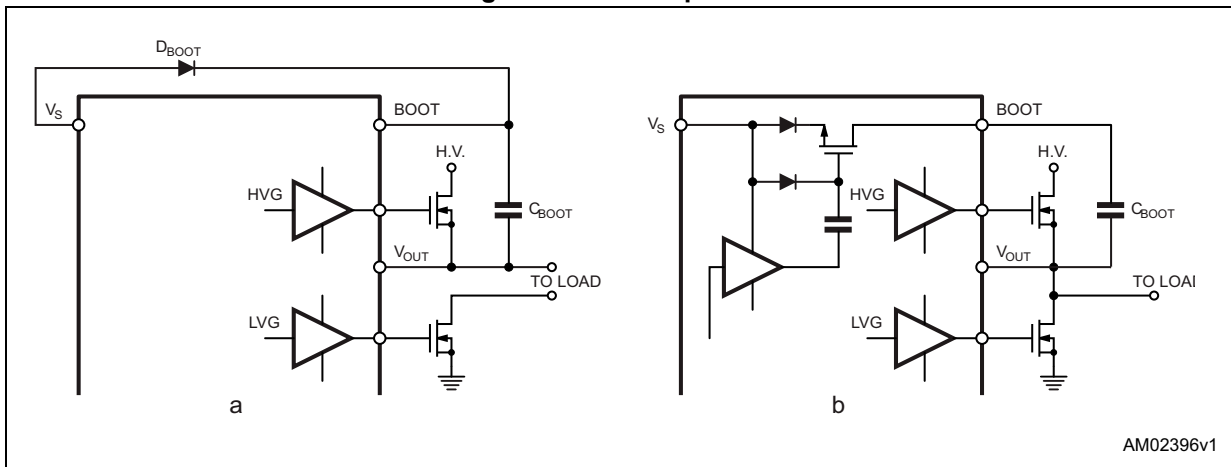

AM02396v1

## 9 Package information

In order to meet environmental requirements, ST offers these devices in different grades of ECOPACK<sup>®</sup> packages, depending on their level of environmental compliance. ECOPACK<sup>®</sup> specifications, grade definitions and product status are available at: [www.st.com](http://www.st.com). ECOPACK<sup>®</sup> is an ST trademark.

### SO-14 package information

Figure 8. SO-14 package outline

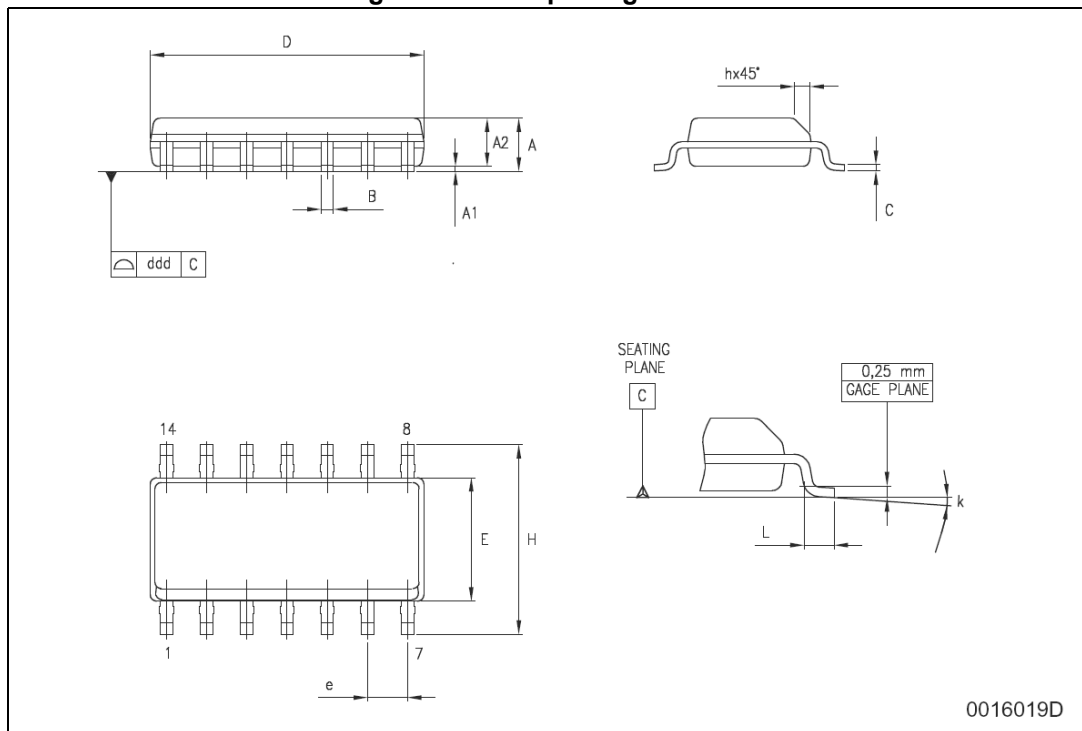
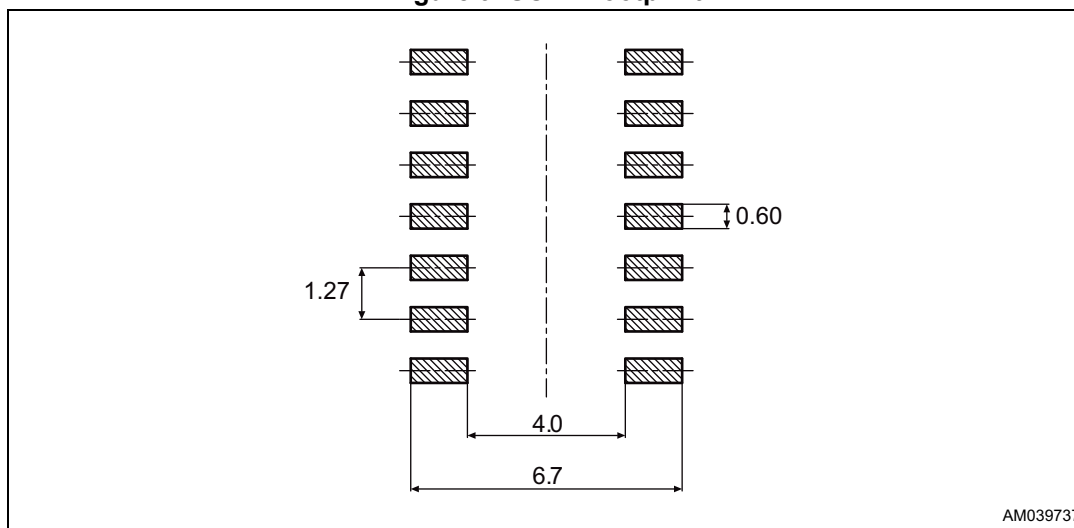



Table 9. SO-14 package mechanical data

Symbol	Dimensions					
	mm			inch		
	Min.	Typ.	Max.	Min.	Typ.	Max.
A			1.75			0.068
a1	0.1		0.2	0.003		0.007
a2			1.65			0.064
b	0.35		0.46	0.013		0.018
b1	0.19		0.25	0.007		0.010
C		0.5			0.019	
c1	45° (typ.)					
D	8.55		8.75	0.336		0.344
E	5.8		6.2	0.228		0.244
e		1.27			0.050	
e3		7.62			0.300	
F	3.8		4.0	0.149		0.157
G	4.6		5.3	0.181		0.208
L	0.5		1.27	0.019		0.050
M			0.68			0.026
S	8° (max.)					

Figure 9. SO-14 footprint



## 10 Order codes

Table 10. Order codes

Order codes	Package	Packaging
L6393D	SO-14	Tube
L6393DTR		Tape and reel

## 11 Revision history

Table 11. Document revision history

Date	Revision	Changes
03-Mar-2008	1	Initial release
18-Mar-2008	2	Cover page updated
17-Nov-2009	3	Updated: Cover page, <a href="#">Table 4 on page 6</a> , <a href="#">Table 6 on page 7</a> , <a href="#">Table 7 on page 8</a> , <a href="#">Table 8 on page 10</a> , <a href="#">Table 9 on page 11</a>
11-Aug-2010	4	Updated: <a href="#">Table 1 on page 1</a> , <a href="#">Table 5 on page 7</a> and <a href="#">Table 7 on page 10</a> .
18-Sep-2015	5	<p>Removed DIP-14 package from the entire document.</p> <p>Updated <a href="#">Table 3 on page 6</a> (added ESD parameter and value, removed note below <a href="#">Table 3</a>).</p> <p>Updated <a href="#">Table 4 on page 6</a> (updated <math>R_{th(JA)}</math> value).</p> <p>Updated <a href="#">Table 7 on page 10</a> (updated <math>V_{il}</math> and <math>V_{ih}</math> parameters and values, updated note 2. below <a href="#">Table 7</a> - replaced <math>V_{CBOOTx}</math> by <math>V_{BOOTx}</math>).</p> <p>Updated <a href="#">Table 8 on page 11</a> (added conditions to title and note 1.).</p> <p>Named and numbered <a href="#">Equation 1 on page 14</a>, <a href="#">Equation 2 on page 14</a> and <a href="#">Equation 3 on page 15</a>.</p> <p>Updated <a href="#">Section 9 on page 16</a> (added/updated titles, reversed order of <a href="#">Figure 8</a> and <a href="#">Table 9</a>, updated header of <a href="#">Table 9</a>, added <a href="#">Figure 9</a>).</p> <p>Updated <a href="#">Table 10 on page 18</a> (moved from page 1 to page 18, added and updated titles).</p> <p>Updated cross-references throughout document.</p> <p>Minor modifications throughout document.</p>

**IMPORTANT NOTICE – PLEASE READ CAREFULLY**

STMicroelectronics NV and its subsidiaries (“ST”) reserve the right to make changes, corrections, enhancements, modifications, and improvements to ST products and/or to this document at any time without notice. Purchasers should obtain the latest relevant information on ST products before placing orders. ST products are sold pursuant to ST’s terms and conditions of sale in place at the time of order acknowledgement.

Purchasers are solely responsible for the choice, selection, and use of ST products and ST assumes no liability for application assistance or the design of Purchasers’ products.

No license, express or implied, to any intellectual property right is granted by ST herein.

Resale of ST products with provisions different from the information set forth herein shall void any warranty granted by ST for such product.

ST and the ST logo are trademarks of ST. All other product or service names are the property of their respective owners.

Information in this document supersedes and replaces information previously supplied in any prior versions of this document.

© 2015 STMicroelectronics – All rights reserved