



L7582 Tip Ring Access Switch

Features

- Small size/surface-mount packaging
- Monolithic IC reliability
- Low impulse noise
- Make-before-break, break-before-make operation
- Clean, bounce-free switching
- Low, matched ON-resistance
- Built-in current limiting, thermal shutdown, and SLIC protection
- 5 V only operation, very low power consumption
- Battery monitor, all OFF state upon loss of battery
- No EMI
- Latched logic level inputs, no drive circuitry
- Only one external protector required

Applications

- Central office
- DLC
- PBX
- DAML
- HFC/FITL

Description

The L7582 Tip Ring Access Switch is a monolithic solid-state device that provides the switching functionality of a 2 form C switch.

The L7582 is designed to provide power ringing access to tip and ring in central office, digital loop carrier, private branch exchange, digitally added main line, and hybrid fiber coax/fiber-in-the-loop analog line card applications.

An additional pair of solid-state contacts provides access to the telephone loop for line test access or message waiting in the PBX application.

The L7582 has four states: the idle talk state (line break switches closed, ringing and loop access switches open), the power ringing state (ringing access switches closed, line break and loop access switches open), loop access state (loop access switches closed, line break and ringing access switches open), and an all OFF state.

The L7582 offers break-before-make or make-before-break switching, with simple logic level input control. Because of the solid-state construction, voltage transients generated when switching into an inductive ringing load during ring cadence or ring trip are minimized, possibly eliminating the need for external zero cross switching circuitry. State control is via logic level inputs so no additional driver circuitry is required.

The line break switch is a linear switch that has exceptionally low ON-resistance and an excellent ON-resistance matching characteristic. The ringing access switch has a breakdown voltage rating >480 V which is sufficiently high, with proper protection, to prevent breakdown in the presence of a transient fault condition (i.e., passing the transient on to the ringing generator).

Incorporated into the L7582Ax is a diode bridge/SCR clamping circuit, current-limiting circuitry, and a thermal shutdown mechanism to provide protection to the SLIC device and subsequent circuitry during fault conditions (see Figure 1). Positive and negative lightning is reduced by the current-limiting circuitry and steered to ground via diodes and the integrated SCR. Power cross is also reduced by the current-limiting and thermal shutdown circuits.

Description (continued)

The L7582Bxx version provides only an integrated diode bridge along with current limiting and thermal shutdown as shown in Figure 2. This will cause positive faults to be directed to ground and negative faults to battery. In either polarity, faults are reduced by the current-limit and/or thermal shutdown mechanisms.

To protect the L7582 from an overvoltage fault condition, use of a secondary protector is required. The secondary protector must limit the voltage seen at the tip/ring terminals to prevent the breakdown voltage of the switches from being exceeded. To minimize stress on the solid-state contacts, use of a foldback- or crowbar- type secondary protector is recommended. With proper choice of secondary protection, a line card using the L7582 will meet all relevant ITU-T, LSSGR, FCC, or UL* protection requirements.

The L7582 operates from a 5 V supply only. This gives the device extremely low idle and active power dissipation and allows use with virtually any range of battery voltage. This makes the L7582 especially appropriate for remote power applications such as DAML or FOC/FITL or other Bellcore TA 909 applications where power dissipation is particularly critical.

A battery voltage is also used by the L7582, only as a reference for the integrated protection circuit. The L7582 will enter an all OFF state upon loss of battery.

During power ringing, to turn on and maintain the ON state, the ring access switch will draw a nominal 2 mA or 4 mA from the ring generator.

The L7582 device is packaged in a 16-pin, plastic DIP package (L7582AC/BC) and a 16-pin, plastic SOG package (L7582AAE/BAE). The L7582AAE/BAE are pin compatible with the L7542AAE/BAE.

*UL is a registered trademark of Underwriters Laboratories, Inc.

Pin Information

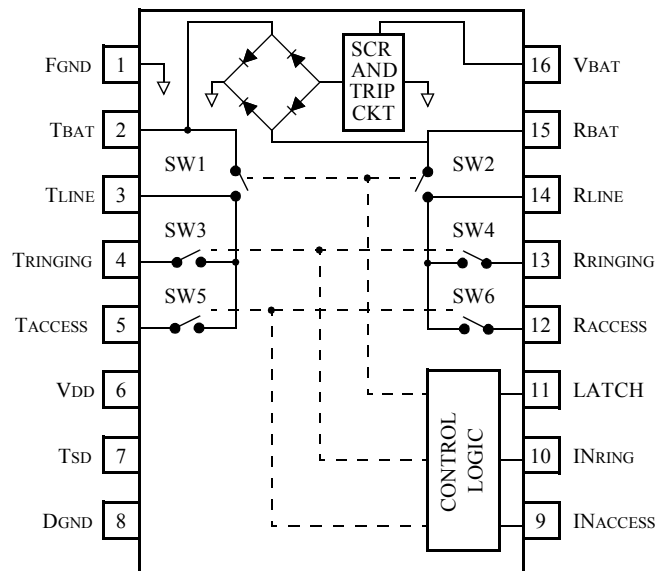

12-2306.i (F)

Note: Shown with A version protection. The 16-pin SOG is available with either A or B version protection.

Figure 1. 16-Pin, Plastic SOG

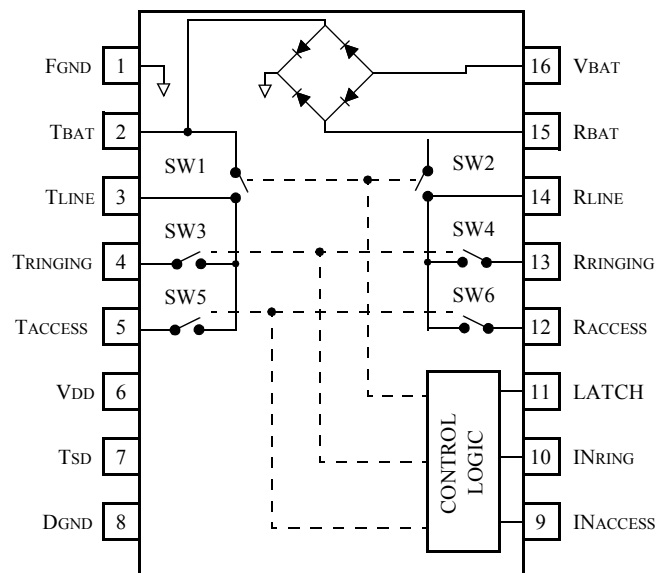

12-2306.e (F)

Note: Shown with B version protection. The 16-pin DIP is available with either A or B version protection.

Figure 2. 16-Pin, Plastic DIP

Pin Information (continued)

Table 1. Pin Descriptions

DIP	SOG	Symbol	Description	DIP	SOG	Symbol	Description
1	1	FGND	Fault ground.	16	16	VBAT	Battery voltage. Used as a reference for protection circuit.
2	2	TBAT	Connect to TIP on SLIC side.	15	15	RBAT	Connect to RING on SLIC side.
3	3	TLINE	Connect to TIP on line side.	14	14	RLINE	Connect to RING on line side.
4	4	TRINGING	Connect to return ground for ringing generator.	13	13	RRINGING	Connect to ringing generator.
5	5	TACCESS	Test access.	12	12	RACCESS	Test access.
6	6	VDD	5 V supply.	11	11	LATCH	Data latch control, active-high, transparent low.
7	7	TSD	Temperature shutdown pin. Can be used as a logic level input or output. See Table 13, Truth Table, and the Switching Behavior section of this data sheet for input pin description. As an output, will read 5 V when device is in its operational mode and 0 V in the thermal shutdown mode. To disable the thermal shutdown mechanism, tie this pin to 5 V (not recommended).	10	10	INRING	Logic level input switch control.
8	8	DGND	Digital ground.	9	9	INACCESS	Logic level input switch control.

Absolute Maximum Ratings

Stresses in excess of the absolute maximum ratings can cause permanent damage to the device. These are absolute stress ratings only. Functional operation of the device is not implied at these or any other conditions in excess of those given in the operational sections of the data sheet. Exposure to absolute maximum ratings for extended periods can adversely affect device reliability.

Table 2. Absolute Maximum Ratings Parameters

Parameter	Min	Max	Unit
Operating Temperature Range	-40	110	°C
Storage Temperature Range	-40	150	°C
Relative Humidity Range	5	95	%
Pin Soldering Temperature (t = 10 s max)	—	260	°C
5 V Power Supply	—	7	V
Battery Supply	—	-85	V
Logic Input Voltage	—	7	V
Input-to-output Isolation	—	330	V
Pole-to-pole Isolation	—	330	V

Handling Precautions

Although protection circuitry has been designed into this device, proper precautions should be taken to avoid exposure to electrostatic discharge (ESD) during handling and mounting. Legerity employs a human-body model (HBM) and a charged-device model (CDM) for ESD-susceptibility testing and protection design evaluation. ESD voltage thresholds are dependent on the circuit parameters used to define the model. No industry-wide standard has been adopted for CDM. However, a standard HBM (resistance = 1500 Ω, capacitance = 100 pF) is widely used and therefore can be used for comparison purposes. The HBM ESD threshold presented here was obtained by using these circuit parameters.

Table 3. HBM ESD Threshold Voltage

Device	Rating
L7582	1000 V

Electrical Characteristics

T_A = -40 °C to +85 °C, unless otherwise specified.

Minimum and maximum values are testing requirements. Typical values are characteristics of the device and are the result of engineering evaluations. Typical values are for information purposes only and are not part of the testing requirements.

Table 4. Power Supply Specifications

Supply	Min	Typ	Max	Unit
V _{DD}	4.5	5	5.5	V
V _{BAT} *	-19	—	-72	V

* V_{BAT} is used only as a reference for internal protection circuitry. If V_{BAT} rises above -10 V, the device will enter an all OFF state and will remain in the all OFF state until the battery voltage drops below -15 V.

Table 5. Break Switches, 1 and 2

Parameter	Test Condition	Measure	Min	Typ	Max	Unit
OFF-state Leakage Current:						
+25 °C	V _{switch (differential)} = -320 V to Gnd	I _{switch}	—	—	1	μA
+85 °C	V _{switch (differential)} = -60 V to +260 V	I _{switch}	—	—	1	μA
-40 °C	V _{switch (differential)} = -330 V to Gnd V _{switch (differential)} = -60 V to +270 V V _{switch (differential)} = -310 V to Gnd V _{switch (differential)} = -60 V to +250 V	I _{switch}	—	—	1	μA
ON-resistance (SW1, SW2):						
+25 °C	T _{LINE} = ±10 mA, ±40 mA, T _{BAT} = -2 V	Δ V _{ON}	—	19.5	—	Ω
+85 °C	T _{LINE} = ±10 mA, ±40 mA, T _{BAT} = -2 V	Δ V _{ON}	—	—	28	Ω
-40 °C	T _{LINE} = ±10 mA, ±40 mA, T _{BAT} = -2 V	Δ V _{ON}	—	14.5	—	Ω
ON-resistance Match	Per ON-resistance test condition of SW1, SW2	Magnitude R _{ON} SW1 – R _{ON} SW2	—	0.2	1.0	Ω
ON-state Voltage*	I _{switch} = I _{LIMIT} @ 50 Hz/60 Hz	V _{ON}	—	—	220	V
dc Current Limit:						
+85 °C	V _{switch (on)} = ±10 V	I _{switch}	80	—	—	mA
-40 °C	V _{switch (on)} = ±10 V	I _{switch}	—	—	250	mA
Dynamic Current Limit (t = < 0.5 μs)	Break switches in ON state; ringing access switches off; apply ±1000 V at 10/1000 μs pulse; appropriate secondary protection in place	I _{switch}	—	2.5	—	A
Isolation:						
+25 °C	V _{switch (both poles)} = ±320 V, Logic inputs = Gnd	I _{switch}	—	—	1	μA
+85 °C	V _{switch (both poles)} = ±330 V, Logic inputs = Gnd	I _{switch}	—	—	1	μA
-40 °C	V _{switch (both poles)} = ±310 V, Logic inputs = Gnd	I _{switch}	—	—	1	μA
dV/dt Sensitivity [†]	—	—	—	200	—	V/μs

* This parameter is not tested in production. Choice of secondary protector should ensure this rating is not exceeded.

† Applied voltage is 100 Vp-p square wave at 100 Hz.

Electrical Characteristics (continued)

Table 6. Ring Return Switch, 3

Parameter	Test Condition	Measure	Min	Typ	Max	Unit
OFF-state Leakage Current (SW3):						
+25 °C	Vswitch (differential) = -320 V to Gnd Vswitch (differential) = -60 V to +260 V	Iswitch	—	—	1	μA
+85 °C	Vswitch (differential) = -330 V to Gnd Vswitch (differential) = -60 V to +270 V	Iswitch	—	—	1	μA
-40 °C	Vswitch (differential) = -310 V to Gnd Vswitch (differential) = -60 V to +250 V	Iswitch	—	—	1	μA
dc Current Limit	Vswitch (on) = ±10 V	Iswitch	—	200	—	mA
Dynamic Current Limit (t = < 0.5 μs)	Break switches in ON state; ringing access switches off; apply ±1000 V at 10/1000 μs pulse; appropriate secondary protection in place	Iswitch	—	2.5	—	A
ON-resistance	Iswitch (on) = ±0 mA, ±10 mA	Δ V _{ON}	—	—	100	Ω
ON-state Voltage*	Iswitch = I _{LIMIT} @ 50 Hz/60 Hz	V _{ON}	—	—	130	V
Isolation:						
+25 °C	Vswitch (both poles) = ±320 V, Logic inputs = Gnd	Iswitch	—	—	1	μA
+85 °C	Vswitch (both poles) = ±330 V, Logic inputs = Gnd	Iswitch	—	—	1	μA
-40 °C	Vswitch (both poles) = ±310 V, Logic inputs = Gnd	Iswitch	—	—	1	μA
dV/dt Sensitivity [†]	—	—	—	200	—	V/μs

* This parameter is not tested in production. Choice of secondary protector should ensure this rating is not exceeded.

† Applied voltage is 100 Vp-p square wave at 100 Hz.

Table 7. Ringing Access Switch, 4

Parameter	Test Condition	Measure	Min	Typ	Max	Unit
OFF-state Leakage Current (SW4):						
+25 °C	Vswitch (differential) = -255 V to +210 V Vswitch (differential) = +255 V to -210 V	Iswitch	—	—	1	μA
+85 °C	Vswitch (differential) = -270 V to +210 V Vswitch (differential) = +270 V to -210 V	Iswitch	—	—	1	μA
-40 °C	Vswitch (differential) = -245 V to +210 V Vswitch (differential) = +245 V to -210 V	Iswitch	—	—	1	μA
ON Voltage	Iswitch (on) = ±1 mA	—	—	—	3	V
Ring Generator Current During Ring	V _{CC} = 5 V I _{NACCESS} = 0	I _{RINGSOURCE}	—	*	—	mA
Steady-state Current [†]	—	—	—	—	150	mA
Surge Current [†]	—	—	—	—	2	A
Release Current	—	—	—	500	—	μA
ON-resistance	Iswitch (on) = ±70 mA, ±80 mA	Δ V _{on}	—	—	12	Ω
Isolation:						
+25 °C	Vswitch (both poles) = ±320 V, Logic inputs = Gnd	Iswitch	—	—	1	μA
+85 °C	Vswitch (both poles) = ±330 V, Logic inputs = Gnd	Iswitch	—	—	1	μA
-40 °C	Vswitch (both poles) = ±310 V, Logic inputs = Gnd	Iswitch	—	—	1	μA
dV/dt Sensitivity [‡]	—	—	—	200	—	V/μs

* At the time of publication of this data sheet, the current device design will be a nominal 4 mA. Devices are being redesigned to reduce this current to less than 2 mA nominally. Consult your Legerity account executive for additional details.

† Choice of secondary protector and series current-limit resistor should ensure these ratings are not exceeded.

‡ Applied voltage is 100 Vp-p square wave at 100 Hz.

Electrical Characteristics (continued)

Table 8. Loop Access Switches, 5 and 6

Parameter	Test Condition	Measure	Min	Typ	Max	Unit
OFF-state Leakage Current: +25 °C	Vswitch (differential) = -320 V to Gnd	Iswitch	—	—	1	μA
+85 °C	Vswitch (differential) = -60 V to +260 V	Iswitch	—	—	1	μA
-40 °C	Vswitch (differential) = -330 V to Gnd Vswitch (differential) = -60 V to +270 V Vswitch (differential) = -310 V to Gnd Vswitch (differential) = -60 V to +250 V	Iswitch	—	—	1	μA
dc Current Limit: +85 °C	Vswitch (on) = ±10 V	Iswitch	80	—	—	mA
-40 °C	Vswitch (on) = ±10 V	Iswitch	—	—	250	mA
Dynamic Current Limit (t = <0.5 μs)	Break switches in ON state; ringing access switches off; apply ±1000 V at 10/1000 μs pulse; appropriate secondary protection in place	Iswitch	—	2.5	—	A
ON-resistance: +25 °C	Iswitch (on) = ±10 mA, ±40 mA	Δ V _{ON}	—	45	—	Ω
+85 °C	Iswitch (on) = ±10 mA, ±40 mA	Δ V _{ON}	—	—	70	Ω
-40 °C	Iswitch (on) = ±10 mA, ±40 mA	Δ V _{ON}	—	33	—	Ω
ON-state Voltage*	Iswitch = I _{LIMIT} @ 50 Hz/60 Hz	V _{ON}	—	—	130	V
Isolation: +25 °C	Vswitch (both poles) = ±320 V, Logic inputs = Gnd	Iswitch	—	—	1	μA
+85 °C	Vswitch (both poles) = ±330 V, Logic inputs = Gnd	Iswitch	—	—	1	μA
-40 °C	Vswitch (both poles) = ±310 V, Logic inputs = Gnd	Iswitch	—	—	1	μA
dV/dt Sensitivity†	—	—	—	200	—	V/μs

* This parameter is not tested in production. Choice of secondary protector should ensure this rating is not exceeded.

† Applied voltage is 100 Vp-p square wave at 100 Hz.

Electrical Characteristics (continued)

Table 9. Additional Electrical Characteristics

Parameter	Test Condition	Measure	Min	Typ	Max	Unit
Digital Input Characteristics:						
Input Low Voltage	—	—	—	—	1.5	V
Input High Voltage	—	—	3.5	—	—	V
Input Leakage Current (high)	$V_{DD} = 5.5\text{ V}$, $V_{BAT} = -75\text{ V}$, $V_{logicin} = 5\text{ V}$	I _{logicin}	—	—	1	μA
Input Leakage Current (low)	$V_{DD} = 5.5\text{ V}$, $V_{BAT} = -75\text{ V}$, $V_{logicin} = 0\text{ V}$	I _{logicin}	—	—	1	μA
Power Requirements:						
Power Dissipation	$V_{DD} = 5\text{ V}$, $V_{BAT} = -48\text{ V}$, idle/talk state or all OFF state, ringing state or access state	I _{DD} , I _{BAT}	—	3	5	mW
V _{DD} Current	$V_{DD} = 5\text{ V}$, idle/talk state or all OFF state, ringing state or access state	I _{DD}	—	560	900	μA
V _{BAT} Current	$V_{BAT} = -48\text{ V}$, idle/talk state or all OFF state, ringing state or access state	I _{BAT}	—	0.750	1.9	mA
Temperature Shutdown Requirements*:						
Shutdown Activation Temperature	—	—	110	125	150	°C
Shutdown Circuit Hysteresis	—	—	10	—	25	°C

* Temperature shutdown flag (TSD) will be high during normal operation and low during temperature shutdown state.

Zero Cross Current Turn Off

The ring access switch (SW4) is designed to turn off on the next zero current crossing after application of the appropriate logic input control. This switch requires a current zero cross to turn off. Switch 4, once on, will remain in the ON state (regardless of logic input) until a current zero cross. Therefore, to ensure proper operation of switch 4, this switch should be connected, via proper impedance, to the ringing generator or some other ac source. Do not attempt to switch pure dc with switch 4.

For a detailed explanation of the operation of switch 4, please refer to the *An Introduction to L758X Series of Line Card Access Switches* Application Note.

Switching Behavior

When switching from the power ringing state to the idle/talk state via simple logic level input control, the L7582 is able to provide control with respect to the timing when the ringing access contacts are released relative to the state of the line break contacts.

Make-before-break operation occurs when the line break switch contacts are closed (or made) before the ringing access switch contact is opened (or broken). Break-before-make operation occurs when the ringing access contact is opened (broken) before the line break switch contacts are closed (made).

Using the logic level input pins IN_{ring} and IN_{access}, either make-before-break or break-before-make operation of the L7582 is easily achieved. The logic sequences for either mode of operation are given in Table 10 and Table 11. See the Truth Table (Table 13) for an explanation of the logic states.

Switching Behavior (continued)

When using an L7582 in the make-before-break mode, during the ring-to-idle transition, for a period of up to one-half the ringing frequency, the ring break switch and the pnpn-type ring access switch can both be in the ON state. This is the maximum time after the logic signal at IN_{RING} has transitioned that the ring access switch is waiting for the next zero current cross, so it can close. During this interval, current that is limited to the dc break switch current-limit value will be sourced from the ring node of the SLIC.

This current is presented to the internal protection circuit.

The SCR may turn on if:

- The SCR-type protector is used (A code)
- By random probability the ring-to-idle transition occurs during a portion of the ring cycle when the ringing voltage exceeds the protection circuit SCR turn-on voltage.
- Current in excess of the SCR's turn-on current is also available.

Once the SCR is triggered on, if the SLIC is capable of supplying current in excess of the holding current, the SCR may be latched on by the SLIC.

The probability of this event depends on the characteristics of the given SLIC and of the holding current of the L7582A device. The SCR hold current distribution is designed to be safely away from the test limit of 80 mA. The higher the distribution, the lower the probability of the latch.

If this situation is of concern for a given board design, either use the A series device in the break-before-make mode (eliminates the original 25 ms current pulse) or use a B series device (eliminates the SCR).

Table 10. Make-Before-Break Operation

ACCESS	INPUT	TSD	State	Timing	Break Switches 1 & 2	Ring Return Switch 3	Ring Access Switch 4	Line Access Switches 5 & 6
0 V	5 V	Float	Power Ringing	—	Open	Closed	Closed	Open
0 V	0 V	Float	Make-before-break	SW4 waiting for next zero current crossing to turn off maximum time—one-half of ringing. In this transition state, current that is limited to the dc break switch current-limit value will be sourced from the ring node of the SLIC.	Closed	Open	Closed	Open
0 V	0 V	Float	Idle/Talk	Zero cross current has occurred.	Closed	Open	Open	Open

Switching Behavior (continued)

Table 11. Break-Before-Make Operation

ACCESS	INPUT	TSD	State	Timing	Break Switches 1 & 2	Ring Return Switch 3	Ring Access Switch 4	Line Access Switches 5 & 6
0 V	5 V	Float	Power Ringing	—	Open	Closed	Closed	Open
5 V	5 V	Float	All Off	Hold this state for ≤ 25 ms. SW4 waiting for zero current to turn off.	Open	Open	Closed	Open
5 V	5 V	Float	All Off	Zero current has occurred and SW4 has opened.	Open	Open	Open	Open
0 V	0 V	Float	Idle/Talk	Release break switches.	Closed	Open	Open	Open

Notes:

Break-before-make operation can also be achieved using TSD as an input. In lines two and three of Table 11, instead of using the logic input pins to force the all OFF state, force TSD to ground. This will override the logic inputs and also force the all OFF state. Hold this state for 25 ms. During this 25 ms all OFF state, toggle the inputs from 10 (ringing state) to 00 (idle/talk state). After 25 ms, release TSD to return switch control to the input pins which will set the idle talk state.

When using the L7582 in this mode, forcing TSD to ground will override the INPUT pins and force an all OFF state. Setting TSD to 5 V will allow switch control via the logic INPUT pins. However, setting TSD to 5 V will also disable the thermal shutdown mechanism. This is not recommended. Therefore, to allow switch control via the logic INPUT pins, allow TSD to float.

Thus, when using TSD as an input, the two recommended states are 0 (overrides logic input pins and forces all OFF state) and float (allows switch control via logic input pins and thermal shutdown mechanism is active). This may require use of an open collector buffer.

Also note that TSD operation in L7582 is different than TSD operation of the L7581, where application of 5 V does not disable the thermal shutdown mechanism.

Power Supplies

Both the 5 V and battery supply are brought onto the L7582. The L7582 requires only the 5 V supply for switch operation; that is, state control is powered exclusively off of the 5 V supply. Because of this, the L7582 offers extremely low power dissipation, both in the idle and active states.

The battery voltage is not used for switch state control. The battery is used as a reference voltage by the integrated secondary protection circuit. When the voltage at TBAT or RBAT drops 2 V to 4 V below the battery, the integrated SCR will trigger, thus preventing fault-induced overvoltage situations at the TBAT/RBAT nodes.

Loss of Battery Voltage

As an additional protection feature, the L7582 monitors the battery voltage. Upon loss of battery voltage, the L7582 will automatically enter an all OFF state and remain in that state until the battery voltage is restored. The L7582 is designed such that the device will enter the all OFF state if the battery rises above -10 V and will remain off until the battery drops

below -15 V.

Monitoring the battery for the automatic shutdown feature will draw a small current from the battery, typically $4 \mu\text{A}$. This will add slightly to the overall power dissipation of the device.

Impulse Noise

Using the L7582 will minimize and possibly eliminate the contribution to the overall system impulse noise that is associated with ringing access switches. Because of this characteristic of the L7582, it may not be necessary to incorporate a zero cross switching scheme. This ultimately depends upon the characteristics of the individual system and is best evaluated at the board level.

Protection

Integrated SLIC Protection

Diode Bridge/SCR

In the L7582A_{xx} version, protection to the SLIC device or other subsequent circuitry is provided by a combination of current-limited break switches, a diode bridge/SCR clamping circuit, and a thermal shutdown mechanism. In the L7582B_{xx} version, protection to the SLIC device or other subsequent circuitry is provided by a combination of current-limited break switches, a diode bridge, and a thermal shutdown mechanism.

In both versions, during a positive lightning event, fault current is directed to ground via steering diodes in the diode bridge. Voltage is clamped to a diode drop above ground. In the A version, negative lightning causes the SCR to conduct when the voltage goes 2 V to 4 V more negative than the battery. Fault currents are then directed to ground via the SCR and steering diodes in the diode bridge.

Note that for the SCR to foldback or crowbar, the ON voltage (see Table 11) of the SCR must be less negative than the battery reference voltage. If the battery voltage is less negative than the SCR ON voltage, the SCR will conduct fault currents to ground; however, it will not crowbar.

In the B version, negative lightning is directed to battery via steering diodes in the diode bridge.

For power cross and power induction faults, in both versions, the positive cycle of the fault is clamped a diode drop above ground and fault currents are steered to ground. In the A version, the negative cycle will cause the SCR to trigger when the voltage exceeds the battery reference voltage by 2 V to 4 V. When the SCR triggers, fault current is steered to ground. In the B version, the negative cycle of the power cross is steered to battery.

Current Limiting

During a lightning event, the current that is passed through the break switches and presented to the integrated protection circuit and subsequent circuitry is limited by the dynamic current-limit response of the break switches (assuming idle/talk state). When the voltage seen at the T_{LINE}/R_{LINE} nodes is properly clamped by an external secondary protector, upon application of a 1000 V 10 x 1000 pulse (LSSGR lightning), the current seen at the T_{BAT}/R_{BAT} nodes will typically be a pulse of magnitude 2.5 A and duration less than 0.5 μs.

During a power cross event, the current that is passed through the break switches and presented to the integrated protection circuit and subsequent circuitry is limited by the dc current-limit response of the break switches (assuming

idle/talk state). The dc current limit is specified over temperature between 100 mA and 250 mA.

Note that the current-limit circuitry has a negative temperature coefficient. Thus, if the device is subjected to an extended power cross, the value of current seen at T_{BAT}/R_{BAT} will decrease as the device heats due to the fault current. If sufficient heating occurs, the temperature shutdown mechanism will activate and the device will enter an all off mode.

Temperature Shutdown Mechanism

When the device temperature reaches a minimum of 110 °C, the thermal shutdown mechanism will activate and force the device into an all OFF state, regardless of the logic input pins. Pin TSD, when used as an output, will read 0 V when the device is in the thermal shutdown mode and +V_{DD} during normal operation.

During a lightning event, due to the relatively short duration, the thermal shutdown will not typically activate.

During an extended power cross, the device temperature will rise and cause the device to enter the thermal shutdown mode. This forces an all off mode, and the current seen at T_{BAT}/R_{BAT} drops to zero. Once in the thermal shutdown mode, the device will cool and exit the thermal shutdown mode, thus reentering the state it was in prior to thermal shutdown. Current, limited to the dc current-limit value, will again begin to flow and device heating will begin again. This cycle of entering and exiting thermal shutdown will last as long as the power-cross fault is present.

If the magnitude of power is great enough, the external secondary protector could trigger, thereby shunting all current to ground.

In the L7582, the thermal shutdown mechanism can be disabled by forcing the TSD pin to +V_{DD}. This functionality differs from the L7581, whose thermal shutdown mechanism cannot be disabled.

Protection (continued)

Integrated SLIC Protection (continued)

External Secondary Protector

With the above integrated protection features, only one over-voltage secondary protection device on the loop side of the L7582 is required. The purpose of this device is to limit fault voltages seen by the L7582 so as not to exceed the breakdown voltage or input-output isolation rating of the device. To minimize stress on the L7582, use of a foldback- or crowbar-type device is recommended. A detailed explanation and design equations on the choice of the external secondary protection device are given in the *An Introduction to L758X Series of Line Card Access Switches* Application Note. Basic design equations governing the choice of external secondary protector are given below:

- $|V_{BATmax}| + |V_{breakovermax}| < |V_{breakdownmin(break)}|$
- $|V_{ringingpeakmax}| + |V_{BATmax}| + |V_{breakovermax}| < |V_{breakdownmin(ring)}|$
- $|V_{ringingpeakmax}| + |V_{BATmax}| < |V_{breakovermin}|$

where:

V_{BATmax} —Maximum magnitude of battery voltage.

$V_{breakovermax}$ —Maximum magnitude breakover voltage of external secondary protector.

$V_{breakovermin}$ —Minimum magnitude breakover voltage of external secondary protector.

$V_{breakdownmin(break)}$ —Minimum magnitude breakdown voltage of L7582 break switch.

$V_{breakdownmin(ring)}$ —Minimum magnitude breakdown voltage of L7582 ring access switch.

$V_{ringingpeakmax}$ —Maximum magnitude peak voltage of ringing signal.

Series current-limiting fused resistors or PTCs should be chosen so as not to exceed the current rating of the external secondary protector. Refer to the manufacturer's data sheet for requirements.

Table 12. Electrical Specifications, Protection Circuitry

Parameters Related to Diodes (in Diode Bridge)						
Parameter	Test Condition	Measure	Min	Typ	Max	Unit
Voltage Drop @ Continuous Current (50 Hz/60 Hz)	Apply \pm dc current limit of break switches	Forward Voltage	—	—	3	V
Voltage Drop @ Surge Current	Apply \pm dynamic current limit of break switches	Forward Voltage	—	5	—	V
Parameters Related to Protection SCR						
Surge Current	—	—	—	—	‡	A
Gate Trigger Current*†	—	—	—	25	50	mA
Gate Trigger Current† Temperature Coefficient	—	—	—	-0.5	—	%/°C
Hold Current	—	—	70	—	—	mA
Gate Trigger Voltage	Trigger current	—	$V_{BAT} - 4$	—	$V_{BAT} - 2$	V
Reverse Leakage Current	V_{BAT}	—	—	—	1.0	μ A
ON-State Voltage§	0.5 A, t = 0.5 μ s	V_{ON}	—	-3	—	V
	2.0 A, t = 0.5 μ s	—	—	-5	—	V

* Previous versions of this data sheet specified a Trigger Current of 50 mA minimum. Trigger Current is defined as the minimum current drawn from tip and ring to turn on the SCR. The specification in this data sheet is Gate Trigger Current, which is defined as the maximum current that can flow into the battery before the SCR turns on.

† Typical at 25 °C.

‡ Twice \pm dynamic current limit of break switches.

§ In some instances, the typical ON-state voltage can range as low as -25 V.

Typical Performance Characteristics

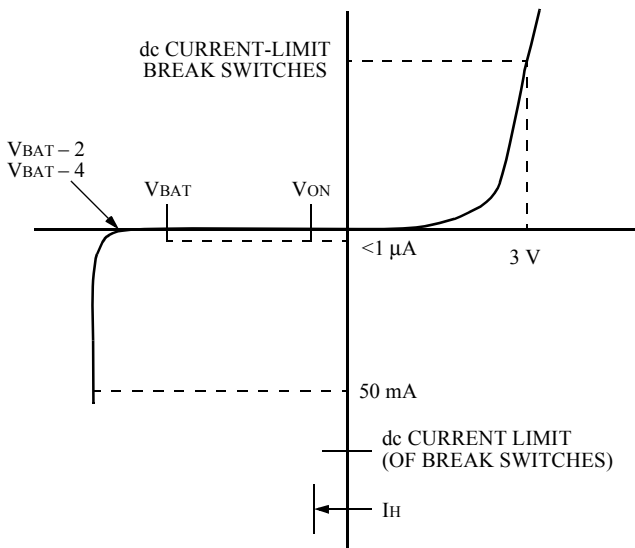

12-2309.f (F)

Figure 3. Protection Circuit A Version

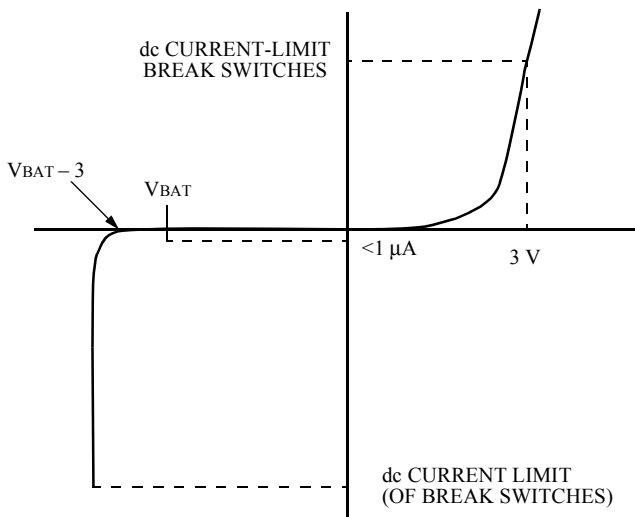

12-2309.b (F)

Figure 4. Protection Circuit B Version

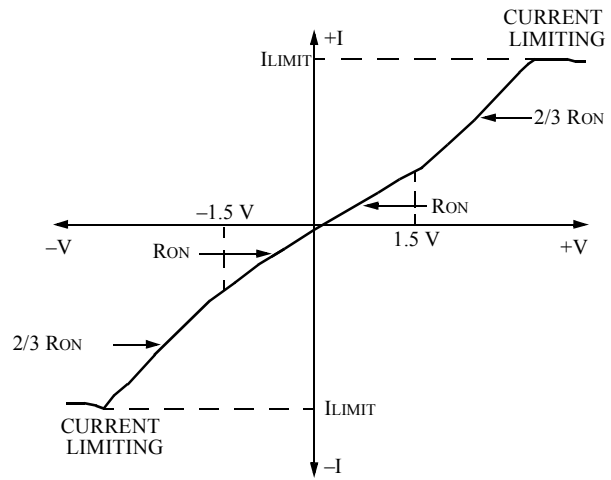

12-2311 (F)

Figure 5. Switches 1—3

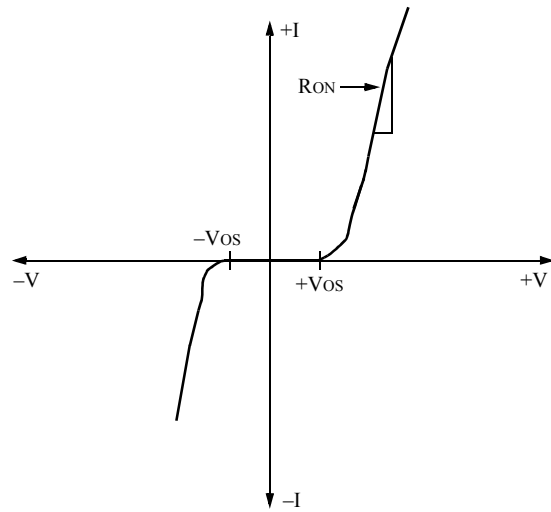

12-2312 (F)

Figure 6. Switch 4

Application

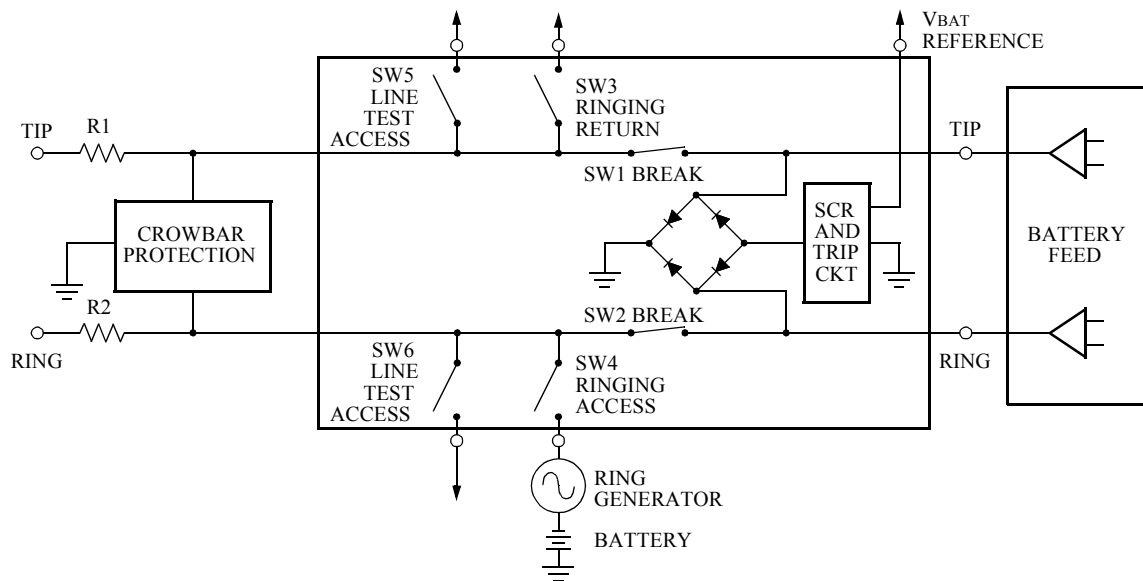

12-2366.c (F)

Figure 7. Typical TRAS Application, Idle, or Talk State Shown

Table 13. Truth Table

Input	Access	TSD	Tip Break Switch	Ring Break Switch	Ringing Return Switch	Ring Switch	Tip Access Switch	Ring Access Switch
0 V	0 V	5 V/Float ¹	On	On	Off	Off	Off	Off ³
5 V	0 V	5 V/Float ¹	Off	Off	On	On	Off	Off ⁴
0 V	5 V	5 V/Float ¹	Off	Off	Off	Off	On	On ⁵
5 V	5 V	5 V/Float ¹	Off	Off	Off	Off	Off	Off ⁶
Don't Care	Don't Care	0 V ²	Off	Off	Off	Off	Off	Off ⁶

1. If TSD = 5 V, the thermal shutdown mechanism is disabled. If TSD is floating, the thermal shutdown mechanism is active.
2. Forcing TSD to ground overrides the logic input pins and forces an all OFF state.
3. Idle/Talk state.
4. Power ringing state.
5. Test out or message waiting state.
6. All OFF state.

A parallel in/parallel out data latch is integrated into the L7582. Operation of the data latch is controlled by the logic level input pin LATCH. The data input to the latch is the INRING and INACCESS pins of the L7582, and the output of the data latch is an internal node used for state control.

When the LATCH control pin is at logic 0, the data latch is transparent and data control signals flow directly from INRING and INACCESS, through the data latch to state control. Any changes in INRING and INACCESS will be reflected in the state of the switches.

When the LATCH control pin is at logic 1, the data latch is

active—the L7582 will no longer react to changes at the INRING and INACCESS control pins. The state of the switches is now latched; that is, the state of the switches will remain as they were when the LATCH input transitioned from logic 0 to logic 1. The switches will not respond to changes in INRING and INACCESS as long as LATCH is held high.

Note that the TSD input is not tied to the data latch. TSD is not affected by the LATCH input. TSD input will override state control via INRING, INACCESS, and LATCH.

Outline Diagrams

16-Pin, Plastic SOG (L7582AAE/BAE)

Note: The dimensions in this outline diagram are intended for informational purposes only. For detailed schematics to assist your design efforts, please contact your Legerity Sales Representative.

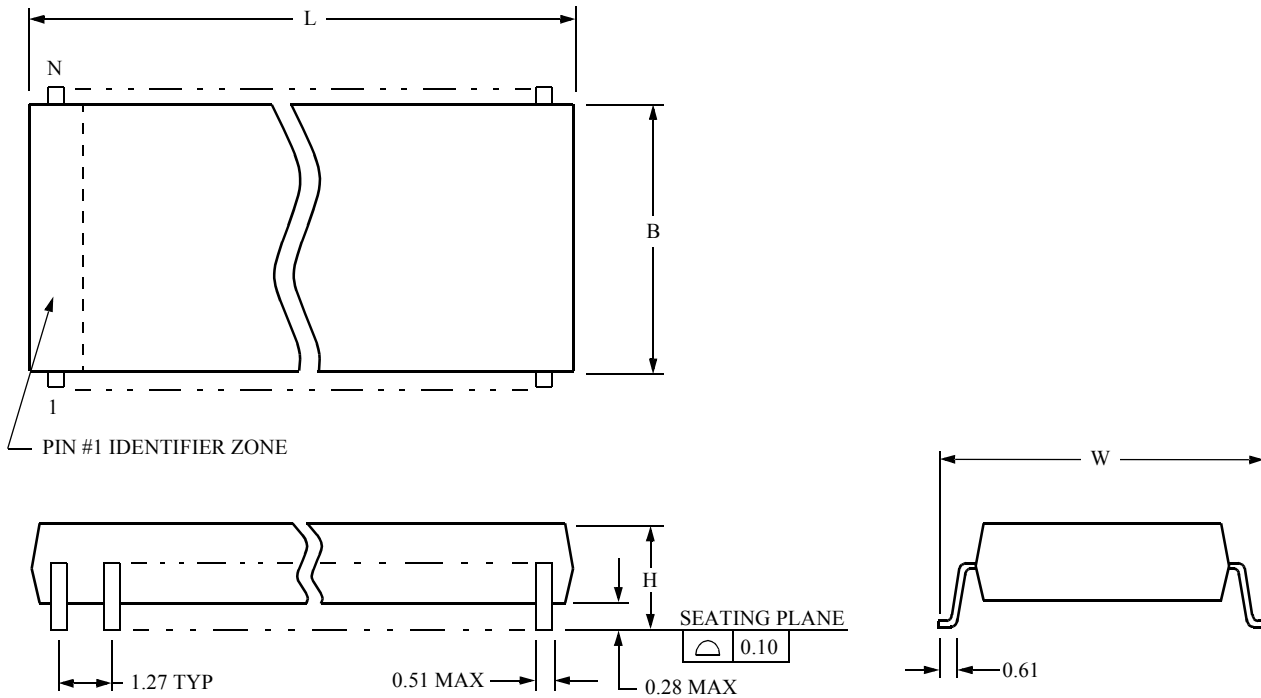

Number of Pins (N)	Maximum Length (L)	Maximum Width Without Leads (B)	Maximum Width Including Leads (W)	Maximum Height Above Board (H)
16	10.49	7.62	10.64	2.67

5-4414 (F)

Outline Diagrams (continued)

16-Pin, Plastic DIP (L7582AC/BC)

Note: The dimensions in this outline diagram are intended for informational purposes only. For detailed schematics to assist your design efforts, please contact your Legerity Sales Representative.

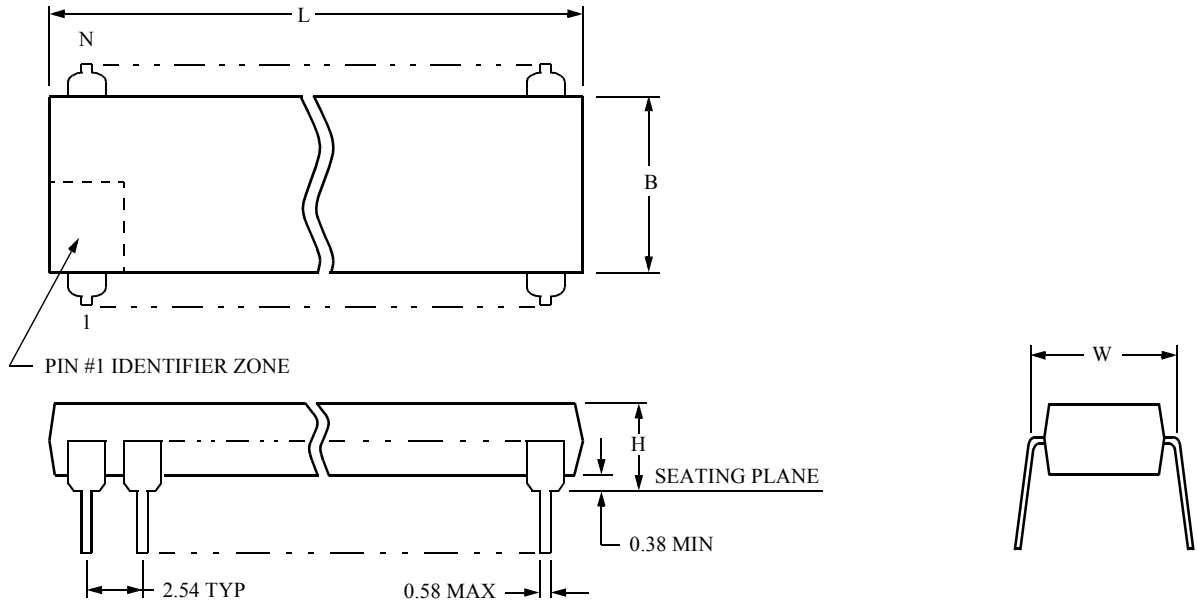

Number of Pins (N)	Maximum Length (L)	Maximum Width Without Leads (B)	Maximum Width Including Leads (W)	Maximum Height Above Board (H)
16	20.57	6.48	7.87	5.08

5-4410 (F)

Ordering Information

Device Part No.	Description	Package	Comcode
ATTL7582AAE	Tip Ring Access Switch	16-pin SOG	107338543
ATTL7582AAE-TR*	Tip Ring Access Switch	16-pin SOG (Tape & Reel)	107338576
ATTL7582AC	Tip Ring Access Switch	16-pin DIP	107394181
ATTL7582BAE	Tip Ring Access Switch	16-pin SOG	107394231
ATTL7582BAE-TR*	Tip Ring Access Switch	16-pin SOG (Tape & Reel)	107394256
ATTL7582BC	Tip Ring Access Switch	16-pin DIP	107394207

*Devices on tape and reel must be ordered in 1000-piece increments.

Legerity, Inc. reserves the right to make changes to the product(s) or information contained herein without notice. No liability is assumed as a result of their use or application. No rights under any patent accompany the sale of any such product(s) or information.



P.O. Box 18200
Austin, Texas 78760-8200

Telephone: (512) 228-5400
Fax: (512) 228-5508
North America Toll Free: (800) 432-4009

*To contact the Legerity Sales Office
nearest you, or to download or order
product literature, visit our website at
www.legerity.com.*

*To order literature in North America,
call:
(800) 432-4009, ext. 75592
or email:
americallit@legerity.com*

*To order literature in Europe or Asia,
call:
44-0-1179-341607
or email:
Europe — eurolit@legerity.com
Asia — asialit@legerity.com*