

Features

- Output current to 0.5 A
- Output voltages of 5; 6; 8; 9; 10; 12; 15; 24 V
- Thermal overload protection
- Short circuit protection
- Output transition SOA protection
- $\pm 2\%$ Output voltage tolerance
- Guaranteed in extended temperature range

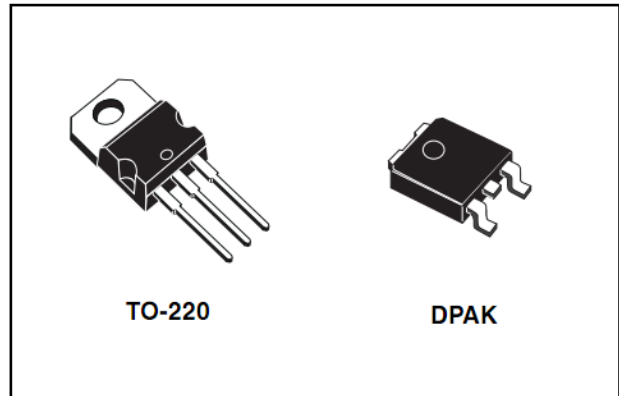

with external components to obtain adjustable voltage and currents.

DESCRIPTION

The L78MxxA series of three-terminal positive regulators is available in TO-220 and DPAK packages and with several fixed output voltages, making it useful in a wide range of applications. These regulators can provide local on-card regulation eliminating the distribution problems associated with single point regulation. Each type employs internal current limiting, thermal shutdown and safe area protection, making it essentially indestructible. If adequate heat sinking is provided, they can deliver over 0.5 A output current. Although designed primarily as fixed voltage regulators, these devices can be used

Table 1. Device summary

Part numbers	
L78M05AB	L78M12AB
L78M05AC	L78M12AC
L78M06AB	L78M15AB
L78M08AB	L78M24AB
L78M09AB	L78M24AC
L78M10AB	

Contents

1 Diagram	3
2 Pin configuration	4
3 Maximum ratings	5
4 Test circuits	6
5 Electrical characteristics	7
6 Typical performance	15
7 Applications information	17
7.1 Design considerations	17
8 Package mechanical data	19
9 Order codes	27
10 Revision history	28

1 Diagram

Figure 1. Block diagram

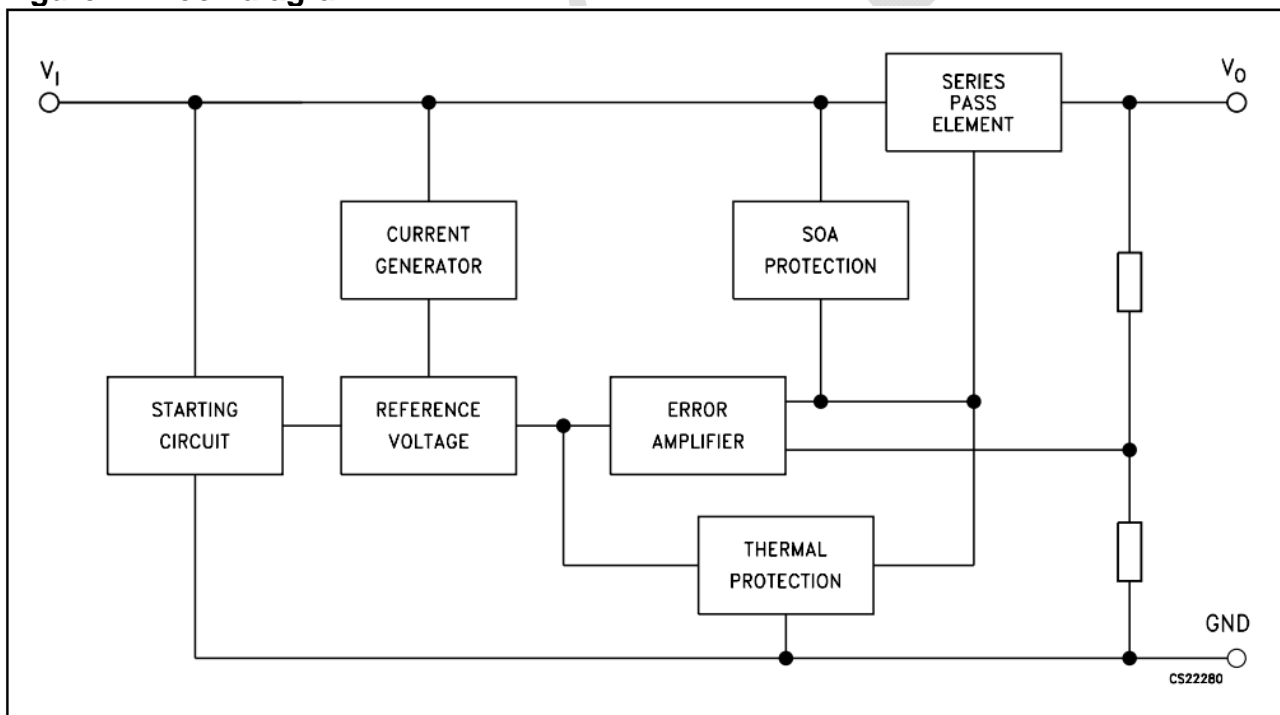

2 Pin configuration

Figure 2. Pin connections (top view)

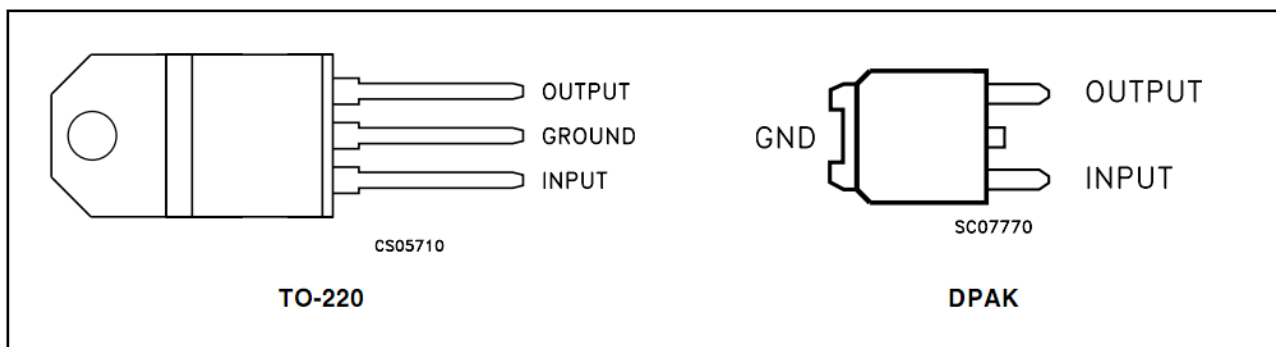
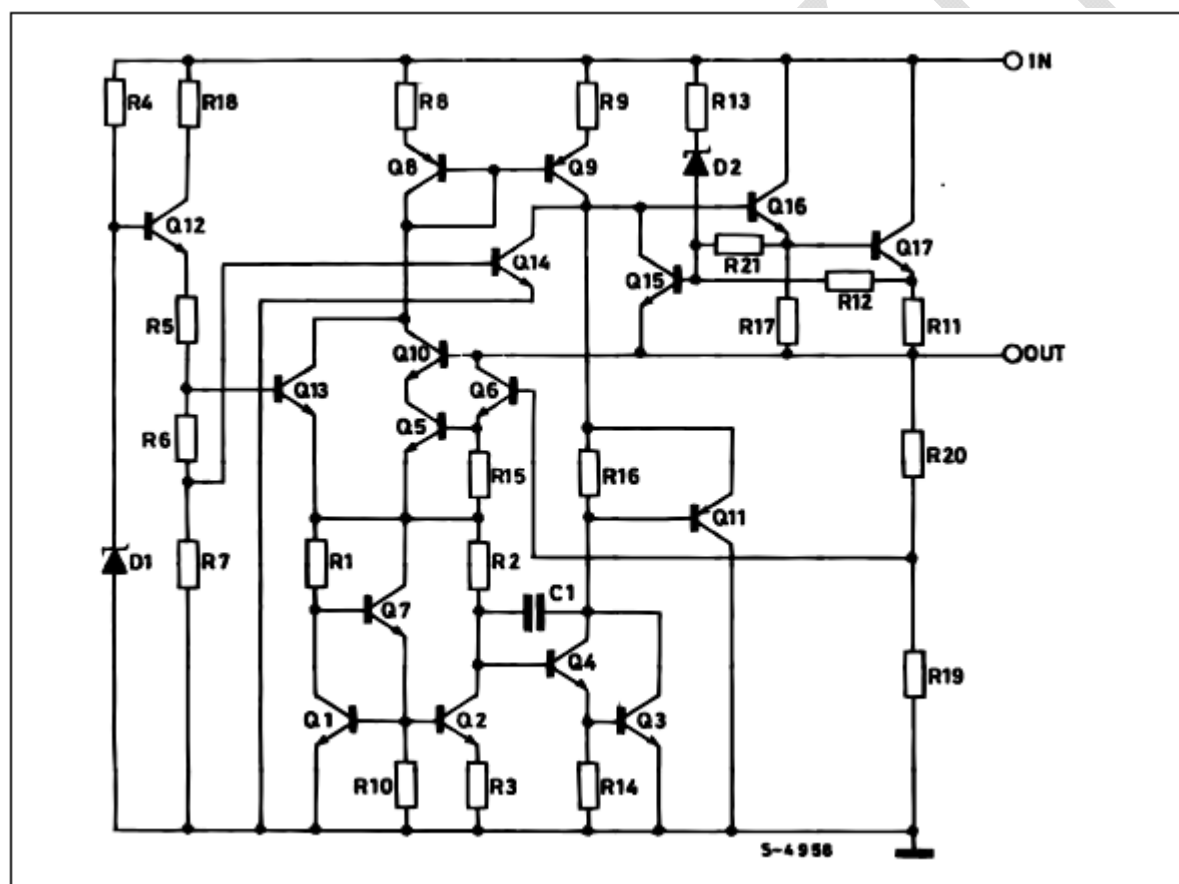

Figure 3. Schematic diagram



3 Maximum ratings

Table 2. Absolute maximum ratings

Symbol	Parameter		Value	Unit
V_I	DC input voltage	for $V_O = 5$ to 18 V	35	V
		for $V_O = 20, 24$ V	40	
I_O	Output current		Internally limited	mA
P_D	Power dissipation		Internally limited	mW
T_{STG}	Storage temperature range		-65 to 150	°C
T_{OP}	Operating junction temperature range	for L78M00AC	0 to 125	°C
		for L78M00AB	-40 to 125	

Note: Absolute maximum ratings are those values beyond which damage to the device may occur. Functional operation under these condition is not implied.

Table 3. Thermal data

Symbol	Parameter	TO-220	DPAK	Unit
R_{thJC}	Thermal resistance junction-case	3	8	° C/W
R_{thJA}	Thermal resistance junction-ambient	50	100	° C/W

Figure 4. Application circuit

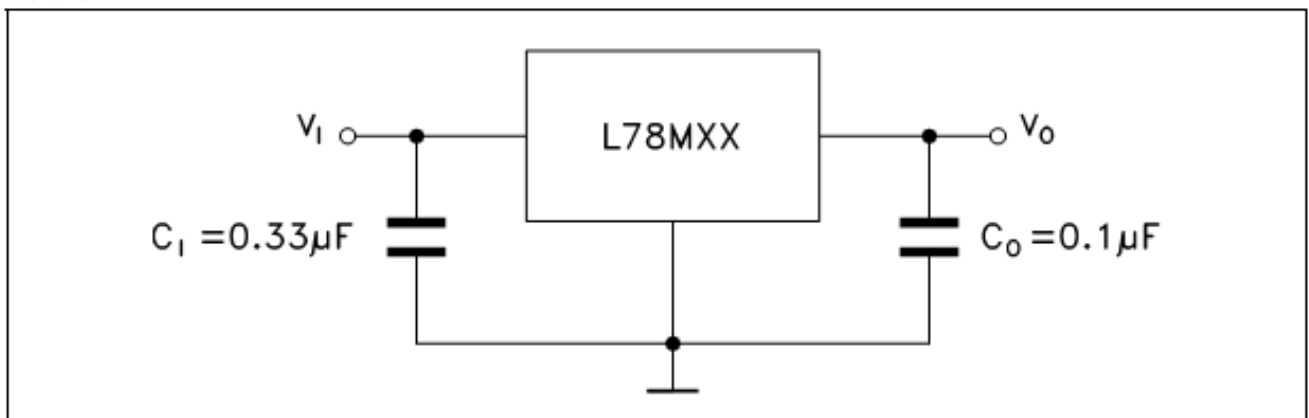

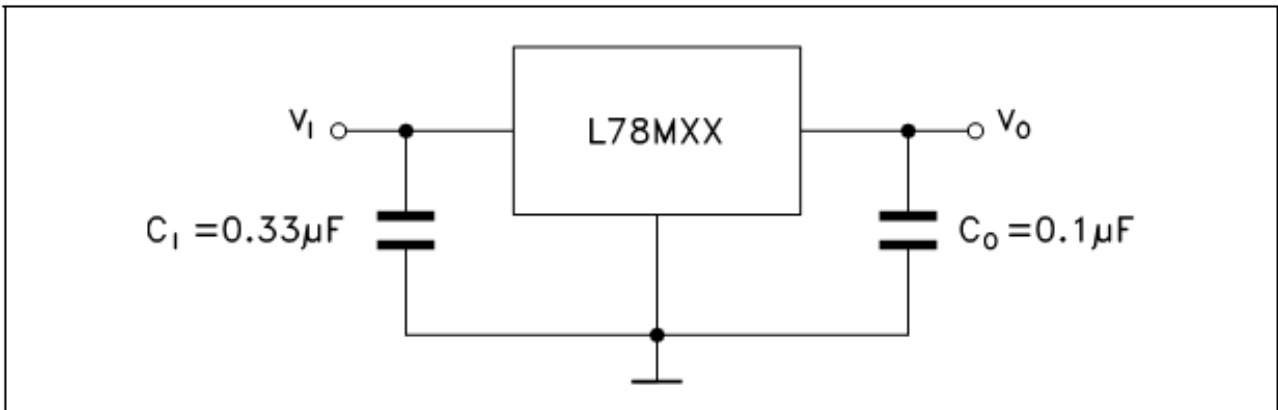
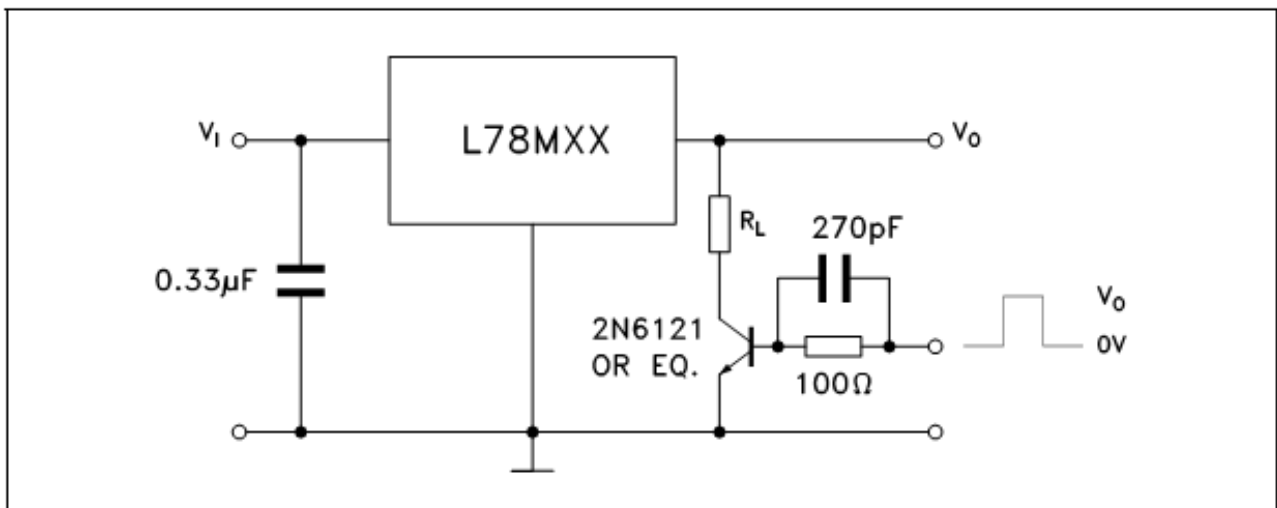
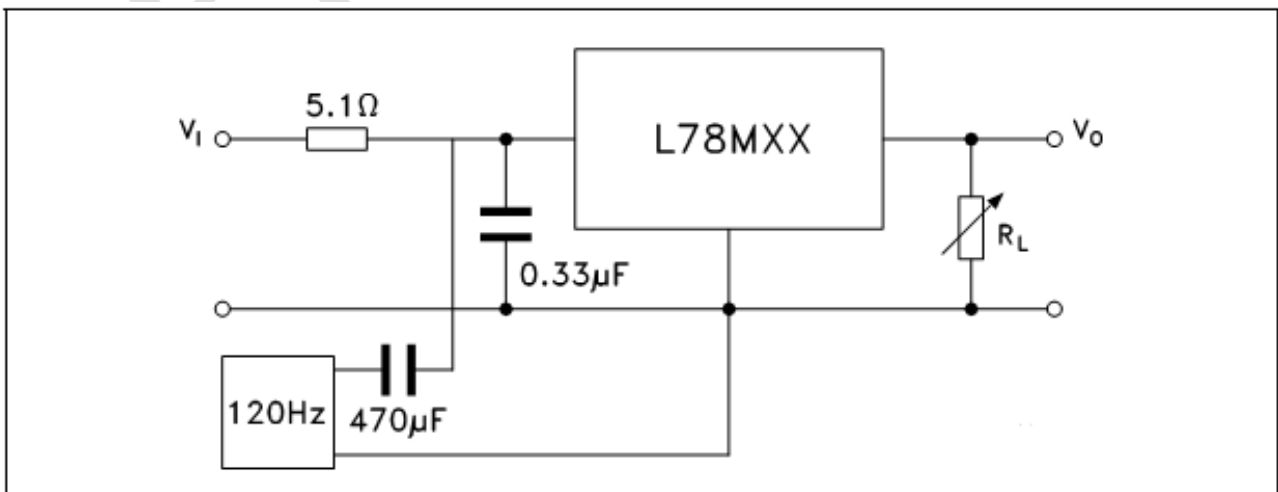
4 Test circuits**Figure 5. DC parameter****Figure 6. Load regulation****Figure 7. Ripple rejection**

5 Electrical characteristics

Refer to the test circuits, $V_I = 10\text{ V}$, $I_O = 350\text{ mA}$, $C_I = 0.33\text{ }\mu\text{F}$, $C_O = 0.1\text{ }\mu\text{F}$,
 $T_J = -40\text{ to }125\text{ }^\circ\text{C}$ (AB), $T_J = 0\text{ to }125\text{ }^\circ\text{C}$ (AC) unless otherwise specified.

Table 4. Electrical characteristics of L78M05XX

Symbol	Parameter	Test conditions	Min.	Typ.	Max.	Unit
V_O	Output voltage	$T_J = 25^\circ\text{C}$	4.9	5	5.1	V
V_O	Output voltage	$I_O = 5\text{ to }350\text{ mA}$, $V_I = 7\text{ to }20\text{ V}$	4.8	5	5.2	V
ΔV_O	Line regulation	$V_I = 7\text{ to }25\text{ V}$, $I_O = 200\text{ mA}$, $T_J = 25^\circ\text{C}$			100	mV
		$V_I = 8\text{ to }25\text{ V}$, $I_O = 200\text{ mA}$, $T_J = 25^\circ\text{C}$			50	
ΔV_O	Load regulation	$I_O = 5\text{ to }500\text{ mA}$, $T_J = 25^\circ\text{C}$			100	mV
		$I_O = 5\text{ to }200\text{ mA}$, $T_J = 25^\circ\text{C}$			50	
I_d	Quiescent current	$T_J = 25^\circ\text{C}$			6	mA
ΔI_d	Quiescent current change	$I_O = 5\text{ to }350\text{ mA}$			0.5	mA
		$I_O = 200\text{ mA}$, $V_I = 8\text{ to }25\text{ V}$			0.8	
$\Delta V_O/\Delta T$	Output voltage drift	$I_O = 5\text{ mA}$		-0.5		mV/ $^\circ\text{C}$
SVR	Supply voltage rejection	$V_I = 8\text{ to }18\text{ V}$, $f = 120\text{ Hz}$, $I_O = 300\text{ mA}$, $T_J = 25^\circ\text{C}$	62			dB
eN	Output noise voltage	$B = 10\text{ Hz to }100\text{ kHz}$, $T_J = 25^\circ\text{C}$		40		μV
V_d	Dropout voltage	$T_J = 25^\circ\text{C}$		2		V
I_{sc}	Short circuit current	$T_J = 25^\circ\text{C}$, $V_I = 35\text{ V}$		300		mA
I_{scp}	Short circuit peak current	$T_J = 25^\circ\text{C}$		700		mA

Refer to the test circuits, $V_I = 11\text{ V}$, $I_O = 350\text{ mA}$, $C_I = 0.33\text{ }\mu\text{F}$, $C_O = 0.1\text{ }\mu\text{F}$,
 $T_J = -40\text{ to }125\text{ }^\circ\text{C}$ (AB), $T_J = 0\text{ to }125\text{ }^\circ\text{C}$ (AC) unless otherwise specified

Table 5. Electrical characteristics of L78M06XX

Symbol	Parameter	Test conditions	Min.	Typ.	Max.	Unit
V_O	Output voltage	$T_J = 25^\circ\text{C}$	5.88	6	6.12	V
V_O	Output voltage	$I_O = 5\text{ to }350\text{ mA}$, $V_I = 8\text{ to }21\text{ V}$	5.75	6	6.3	V
ΔV_O	Line regulation	$V_I = 8\text{ to }25\text{ V}$, $I_O = 200\text{ mA}$, $T_J = 25^\circ\text{C}$			100	mV
		$V_I = 9\text{ to }25\text{ V}$, $I_O = 200\text{ mA}$, $T_J = 25^\circ\text{C}$			30	
ΔV_O	Load regulation	$I_O = 5\text{ to }500\text{ mA}$, $T_J = 25^\circ\text{C}$			120	mV
		$I_O = 5\text{ to }200\text{ mA}$, $T_J = 25^\circ\text{C}$			60	
I_d	Quiescent current	$T_J = 25^\circ\text{C}$			6	mA
ΔI_d	Quiescent current change	$I_O = 5\text{ to }350\text{ mA}$			0.5	mA
		$I_O = 200\text{ mA}$, $V_I = 9\text{ to }25\text{ V}$			0.8	
$\Delta V_O/\Delta T$	Output voltage drift	$I_O = 5\text{ mA}$		-0.5		mV/ $^\circ\text{C}$
SVR	Supply voltage rejection	$V_I = 9\text{ to }19\text{ V}$, $f = 120\text{ Hz}$, $I_O = 300\text{ mA}$, $T_J = 25^\circ\text{C}$	59			dB
eN	Output noise voltage	$B = 10\text{ Hz to }100\text{ kHz}$, $T_J = 25^\circ\text{C}$		45		μV
V_d	Dropout voltage	$T_J = 25^\circ\text{C}$		2		V
I_{sc}	Short circuit current	$T_J = 25^\circ\text{C}$, $V_I = 35\text{ V}$		270		mA
I_{scp}	Short circuit peak current	$T_J = 25^\circ\text{C}$		700		mA

Refer to the test circuits, $V_I = 14\text{ V}$, $I_O = 350\text{ mA}$, $C_I = 0.33\text{ }\mu\text{F}$, $C_O = 0.1\text{ }\mu\text{F}$, $T_J = -40\text{ to }125$

$^{\circ}\text{C}$ (AB), $T_J = 0\text{ to }125\text{ }^{\circ}\text{C}$ (AC) unless otherwise specified).

Table 6. Electrical characteristics of L78M08XX

Symbol	Parameter	Test conditions	Min.	Typ.	Max.	Unit
V_O	Output voltage	$T_J = 25^{\circ}\text{C}$	7.84	8	8.16	V
V_O	Output voltage	$I_O = 5\text{ to }350\text{ mA}$, $V_I = 10.5\text{ to }23\text{ V}$	7.7	8	8.3	V
ΔV_O	Line regulation	$V_I = 10.5\text{ to }25\text{ V}$, $I_O = 200\text{ mA}$, $T_J = 25^{\circ}\text{C}$			100	mV
		$V_I = 11\text{ to }25\text{ V}$, $I_O = 200\text{ mA}$, $T_J = 25^{\circ}\text{C}$			30	
ΔV_O	Load regulation	$I_O = 5\text{ to }500\text{ mA}$, $T_J = 25^{\circ}\text{C}$			160	mV
		$I_O = 5\text{ to }200\text{ mA}$, $T_J = 25^{\circ}\text{C}$			80	
I_d	Quiescent current	$T_J = 25^{\circ}\text{C}$			6	mA
ΔI_d	Quiescent current change	$I_O = 5\text{ to }350\text{ mA}$			0.5	mA
		$I_O = 200\text{ mA}$, $V_I = 10.5\text{ to }25\text{ V}$			0.8	
$\Delta V_O/\Delta T$	Output voltage drift	$I_O = 5\text{ mA}$		-0.5		mV/ $^{\circ}\text{C}$
SVR	Supply voltage rejection	$V_I = 11.5\text{ to }21.5\text{ V}$, $f = 120\text{ Hz}$, $I_O = 300\text{ mA}$, $T_J = 25^{\circ}\text{C}$	56			dB
eN	Output noise voltage	$B = 10\text{ Hz to }100\text{ kHz}$, $T_J = 25^{\circ}\text{C}$		52		μV
V_d	Dropout voltage	$T_J = 25^{\circ}\text{C}$		2		V
I_{sc}	Short circuit current	$T_J = 25^{\circ}\text{C}$, $V_I = 35\text{ V}$		250		mA
I_{scp}	Short circuit peak current	$T_J = 25^{\circ}\text{C}$		700		mA

Refer to the test circuits, $V_I = 15\text{ V}$, $I_O = 350\text{ mA}$, $C_I = 0.33\text{ }\mu\text{F}$, $C_O = 0.1\text{ }\mu\text{F}$,
 $T_J = -40\text{ to }125\text{ }^\circ\text{C}$ (AB), $T_J = 0\text{ to }125\text{ }^\circ\text{C}$ (AC) unless otherwise specified).

Table 7. Electrical characteristics of L78M09XX

Symbol	Parameter	Test conditions	Min.	Typ.	Max.	Unit
V_O	Output voltage	$T_J = 25^\circ\text{C}$	8.82	9	9.18	V
V_O	Output voltage	$I_O = 5\text{ to }350\text{ mA}$, $V_I = 11.5\text{ to }24\text{ V}$	8.64	9	9.36	V
ΔV_O	Line regulation	$V_I = 11.5\text{ to }25\text{ V}$, $I_O = 200\text{ mA}$, $T_J = 25^\circ\text{C}$			100	mV
		$V_I = 12\text{ to }25\text{ V}$, $I_O = 200\text{ mA}$, $T_J = 25^\circ\text{C}$			30	
ΔV_O	Load regulation	$I_O = 5\text{ to }500\text{ mA}$, $T_J = 25^\circ\text{C}$			180	mV
		$I_O = 5\text{ to }200\text{ mA}$, $T_J = 25^\circ\text{C}$			90	
I_d	Quiescent current	$T_J = 25^\circ\text{C}$			6	mA
ΔI_d	Quiescent current change	$I_O = 5\text{ to }350\text{ mA}$			0.5	mA
		$I_O = 200\text{ mA}$, $V_I = 11.5\text{ to }25\text{ V}$			0.8	
$\Delta V_O/\Delta T$	Output voltage drift	$I_O = 5\text{ mA}$		-0.5		mV/ $^\circ\text{C}$
SVR	Supply voltage rejection	$V_I = 12.5\text{ to }23\text{ V}$, $f = 120\text{ Hz}$, $I_O = 300\text{ mA}$, $T_J = 25^\circ\text{C}$	56			dB
eN	Output noise voltage	$B = 10\text{ Hz to }100\text{ kHz}$, $T_J = 25^\circ\text{C}$		52		μV
V_d	Dropout voltage	$T_J = 25^\circ\text{C}$		2		V
I_{sc}	Short circuit current	$V_I = 35\text{ V}$, $T_J = 25^\circ\text{C}$		250		mA
I_{scp}	Short circuit peak current	$T_J = 25^\circ\text{C}$		700		mA

Refer to the test circuits, $V_I = 16\text{ V}$, $I_O = 350\text{ mA}$, $C_I = 0.33\text{ }\mu\text{F}$, $C_O = 0.1\text{ }\mu\text{F}$,

$T_J = -40\text{ to }125\text{ }^\circ\text{C}$ (AB), $T_J = 0\text{ to }125\text{ }^\circ\text{C}$ (AC) unless otherwise specified.

Table 8. Electrical characteristics of L78M10XX

Symbol	Parameter	Test conditions	Min.	Typ.	Max.	Unit
V_O	Output voltage	$T_J = 25^\circ\text{C}$	9.8	10	10.2	V
V_O	Output voltage	$I_O = 5\text{ to }350\text{ mA}$, $V_I = 12.5\text{ to }25\text{ V}$	9.8	10	10.4	V
ΔV_O	Line regulation	$V_I = 12.5\text{ to }30\text{ V}$, $I_O = 200\text{ mA}$, $T_J = 25^\circ\text{C}$			100	mV
		$V_I = 13\text{ to }30\text{ V}$, $I_O = 200\text{ mA}$, $T_J = 25^\circ\text{C}$			30	
ΔV_O	Load regulation	$I_O = 5\text{ to }500\text{ mA}$, $T_J = 25^\circ\text{C}$			200	mV
		$I_O = 5\text{ to }200\text{ mA}$, $T_J = 25^\circ\text{C}$			100	
I_d	Quiescent current	$T_J = 25^\circ\text{C}$			6	mA
ΔI_d	Quiescent current change	$I_O = 5\text{ to }350\text{ mA}$			0.5	mA
		$I_O = 200\text{ mA}$, $V_I = 12.5\text{ to }30\text{ V}$			0.8	
$\Delta V_O/\Delta T$	Output voltage drift	$I_O = 5\text{ mA}$		-0.5		mV/ $^\circ\text{C}$
SVR	Supply voltage rejection	$V_I = 13.5\text{ to }24\text{ V}$, $f = 120\text{ Hz}$, $I_O = 300\text{ mA}$, $T_J = 25^\circ\text{C}$	56			dB
eN	Output noise voltage	$B = 10\text{ Hz to }100\text{ kHz}$, $T_J = 25^\circ\text{C}$		64		μV
V_d	Dropout voltage	$T_J = 25^\circ\text{C}$		2		V
I_{sc}	Short circuit current	$V_I = 35\text{ V}$, $T_J = 25^\circ\text{C}$		245		mA
I_{scp}	Short circuit peak current	$T_J = 25^\circ\text{C}$		700		mA

Refer to the test circuits, $V_I = 19\text{ V}$, $I_O = 350\text{ mA}$, $C_I = 0.33\text{ }\mu\text{F}$, $C_O = 0.1\text{ }\mu\text{F}$,
 $T_J = -40\text{ to }125\text{ }^\circ\text{C}$ (AB), $T_J = 0\text{ to }125\text{ }^\circ\text{C}$ (AC) unless otherwise specified.

Table 9. Electrical characteristics of L78M12XX

Symbol	Parameter	Test conditions	Min.	Typ.	Max.	Unit
V_O	Output voltage	$T_J = 25^\circ\text{C}$	11.75	12	12.25	V
V_O	Output voltage	$I_O = 5\text{ to }350\text{ mA}$, $V_I = 14.5\text{ to }27\text{ V}$	11.5	12	12.5	V
ΔV_O	Line regulation	$V_I = 14.5\text{ to }30\text{ V}$, $I_O = 200\text{ mA}$, $T_J = 25^\circ\text{C}$			100	mV
		$V_I = 16\text{ to }30\text{ V}$, $I_O = 200\text{ mA}$, $T_J = 25^\circ\text{C}$			30	
ΔV_O	Load regulation	$I_O = 5\text{ to }500\text{ mA}$, $T_J = 25^\circ\text{C}$			240	mV
		$I_O = 5\text{ to }200\text{ mA}$, $T_J = 25^\circ\text{C}$			120	
I_d	Quiescent current	$T_J = 25^\circ\text{C}$			6	mA
ΔI_d	Quiescent current change	$I_O = 5\text{ to }350\text{ mA}$			0.5	mA
		$I_O = 200\text{ mA}$, $V_I = 14.5\text{ to }30\text{ V}$			0.8	
$\Delta V_O/\Delta T$	Output voltage drift	$I_O = 5\text{ mA}$		-1		mV/°C
SVR	Supply voltage rejection	$V_I = 15\text{ to }25\text{ V}$, $f = 120\text{ Hz}$, $I_O = 300\text{ mA}$, $T_J = 25^\circ\text{C}$	55			dB
eN	Output noise voltage	$B = 10\text{ Hz to }100\text{ kHz}$, $T_J = 25^\circ\text{C}$		75		μV
V_d	Dropout voltage	$T_J = 25^\circ\text{C}$		2		V
I_{sc}	Short circuit current	$V_I = 35\text{ V}$, $T_J = 25^\circ\text{C}$		240		mA
I_{scp}	Short circuit peak current	$T_J = 25^\circ\text{C}$		700		mA

Refer to the test circuits, $V_I = 23\text{ V}$, $I_O = 350\text{ mA}$, $C_I = 0.33\text{ }\mu\text{F}$, $C_O = 0.1\text{ }\mu\text{F}$,
 $T_J = -40\text{ to }125\text{ }^\circ\text{C}$ (AB), $T_J = 0\text{ to }125\text{ }^\circ\text{C}$ (AC) unless otherwise specified.

Table 10. Electrical characteristics of L78M15XX

Symbol	Parameter	Test conditions	Min.	Typ.	Max.	Unit
V_O	Output voltage	$T_J = 25^\circ\text{C}$	14.7	15	15.3	V
V_O	Output voltage	$I_O = 5\text{ to }350\text{ mA}$, $V_I = 17.5\text{ to }30\text{ V}$	14.4	15	15.6	V
ΔV_O	Line regulation	$V_I = 17.5\text{ to }30\text{ V}$, $I_O = 200\text{ mA}$, $T_J = 25^\circ\text{C}$			100	mV
		$V_I = 20\text{ to }30\text{ V}$, $I_O = 200\text{ mA}$, $T_J = 25^\circ\text{C}$			30	
ΔV_O	Load regulation	$I_O = 5\text{ to }500\text{ mA}$, $T_J = 25^\circ\text{C}$			300	mV
		$I_O = 5\text{ to }200\text{ mA}$, $T_J = 25^\circ\text{C}$			150	
I_d	Quiescent current	$T_J = 25^\circ\text{C}$			6	mA
ΔI_d	Quiescent current change	$I_O = 5\text{ to }350\text{ mA}$			0.5	mA
		$I_O = 200\text{ mA}$, $V_I = 17.5\text{ to }30\text{ V}$			0.8	
$\Delta V_O/\Delta T$	Output voltage drift	$I_O = 5\text{ mA}$		-1		mV/°C
SVR	Supply voltage rejection	$V_I = 18.5\text{ to }28.5\text{ V}$, $f = 120\text{ Hz}$, $I_O = 300\text{ mA}$, $T_J = 25^\circ\text{C}$	54			dB
eN	Output noise voltage	$B = 10\text{ Hz to }100\text{ kHz}$, $T_J = 25^\circ\text{C}$		90		μV
V_d	Dropout voltage	$T_J = 25^\circ\text{C}$		2		V
I_{sc}	Short circuit current	$V_I = 35\text{ V}$, $T_J = 25^\circ\text{C}$		240		mA
I_{scp}	Short circuit peak current	$T_J = 25^\circ\text{C}$		700		mA

Refer to the test circuits, $V_I = 33\text{ V}$, $I_O = 350\text{ mA}$, $C_I = 0.33\text{ }\mu\text{F}$, $C_O = 0.1\text{ }\mu\text{F}$,
 $T_J = -40\text{ to }125\text{ }^\circ\text{C}$ (AB), $T_J = 0\text{ to }125\text{ }^\circ\text{C}$ (AC) unless otherwise specified.

Table 11. Electrical characteristics of L78M24XX

Symbol	Parameter	Test conditions	Min.	Typ.	Max.	Unit
V_O	Output voltage	$T_J = 25^\circ\text{C}$	23.5	24	24.5	V
V_O	Output voltage	$I_O = 5\text{ to }350\text{ mA}$, $V_I = 27\text{ to }38\text{ V}$	23	24	25	V
ΔV_O	Line regulation	$V_I = 27\text{ to }38\text{ V}$, $I_O = 200\text{ mA}$, $T_J = 25^\circ\text{C}$			100	mV
		$V_I = 28\text{ to }38\text{ V}$, $I_O = 200\text{ mA}$, $T_J = 25^\circ\text{C}$			30	
ΔV_O	Load regulation	$I_O = 5\text{ to }500\text{ mA}$, $T_J = 25^\circ\text{C}$			480	mV
		$I_O = 5\text{ to }200\text{ mA}$, $T_J = 25^\circ\text{C}$			240	
I_d	Quiescent current	$T_J = 25^\circ\text{C}$			6	mA
ΔI_d	Quiescent current change	$I_O = 5\text{ to }350\text{ mA}$			0.5	mA
		$I_O = 200\text{ mA}$, $V_I = 27\text{ to }38\text{ V}$			0.8	
$\Delta V_O/\Delta T$	Output voltage drift	$I_O = 5\text{ mA}$		-1.2		mV/ $^\circ\text{C}$
SVR	Supply voltage rejection	$V_I = 28\text{ to }38\text{ V}$, $f = 120\text{ Hz}$, $I_O = 300\text{ mA}$, $T_J = 25^\circ\text{C}$	50			dB
eN	Output noise voltage	$B = 10\text{ Hz to }100\text{ kHz}$, $T_J = 25^\circ\text{C}$		170		μV
V_d	Dropout voltage	$T_J = 25^\circ\text{C}$		2		V
I_{sc}	Short circuit current	$V_I = 35\text{ V}$, $T_J = 25^\circ\text{C}$		240		mA
I_{scp}	Short circuit peak current	$T_J = 25^\circ\text{C}$		700		mA

6 Typical performance

Figure 8. Dropout voltage vs. junction temp. Figure 9. Dropout characteristics

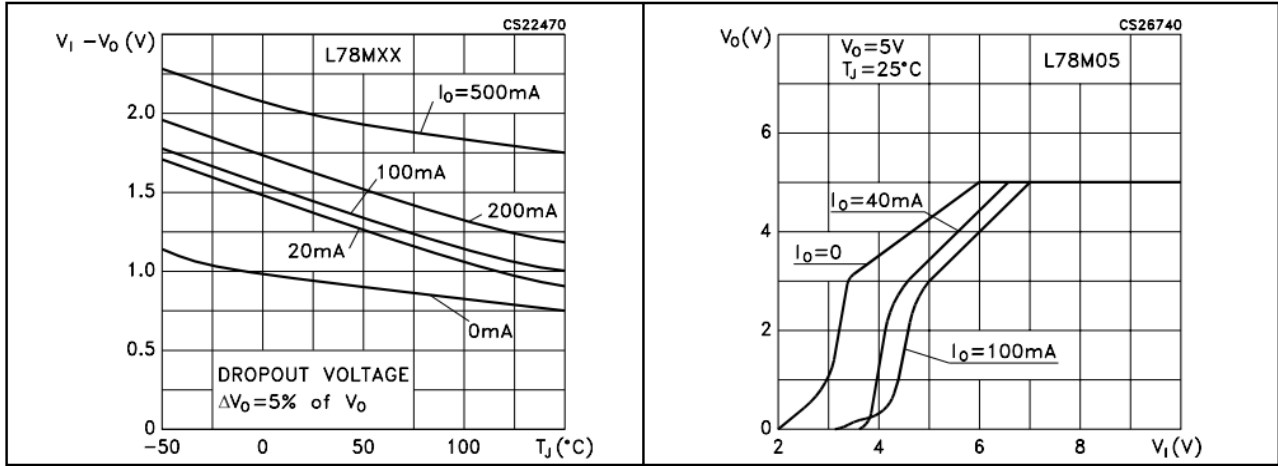

Figure 10. Peak output current vs. input-output differential voltage

Figure 11. Output voltage vs. junction temperature

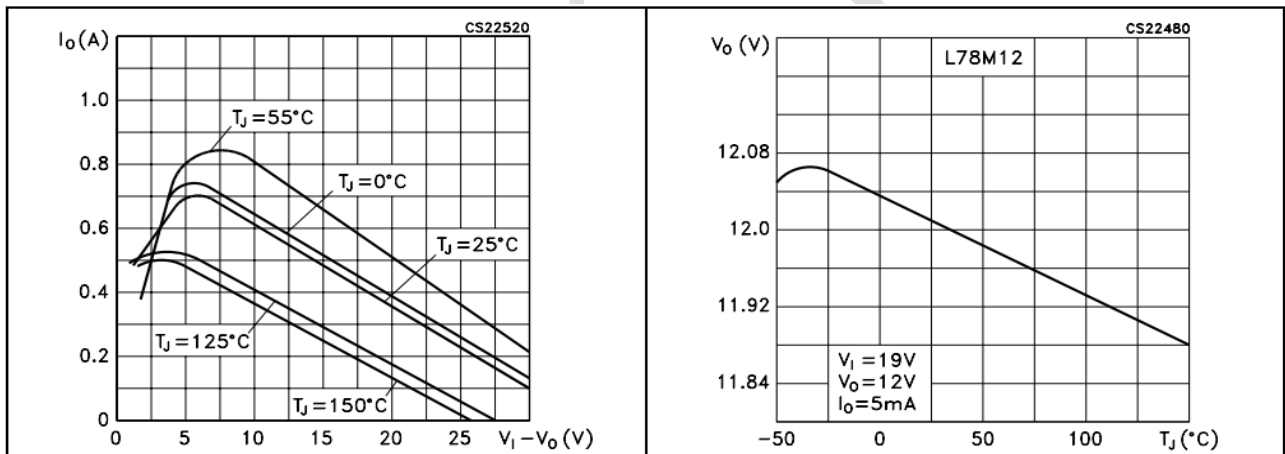

Figure 12. Supply voltage rejection vs. freq. Figure 13. Quiescent current vs. junction temp.

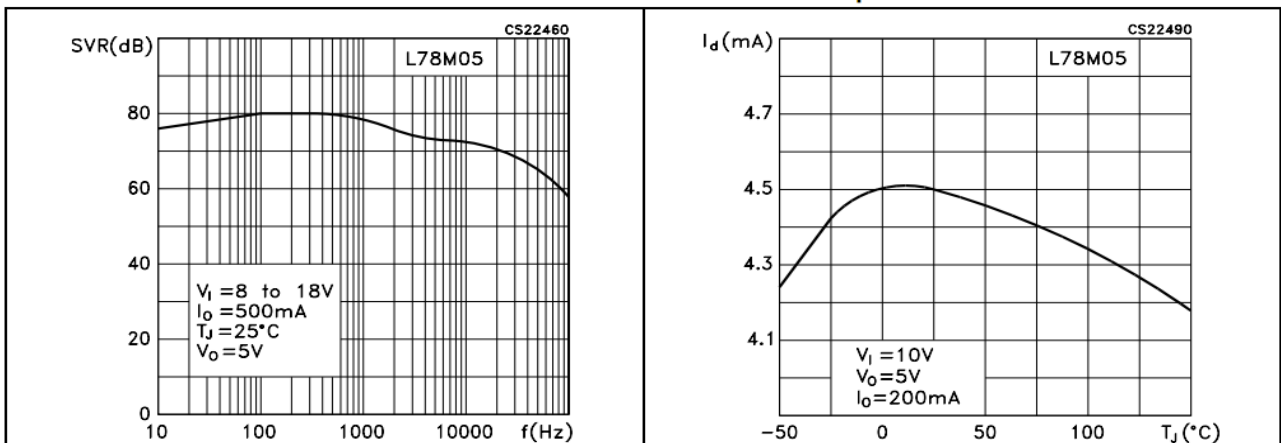

Figure 14. Load transient response

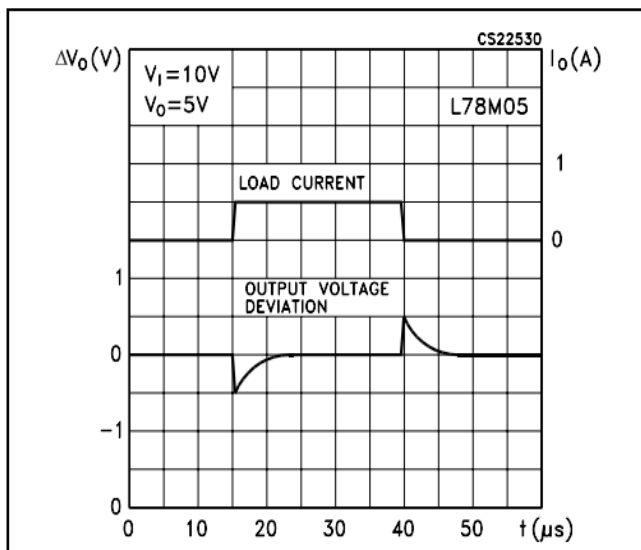

Figure 15. Line transient response

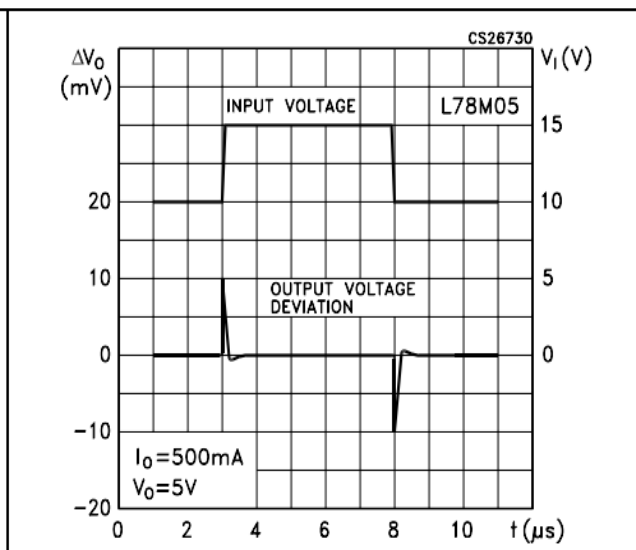
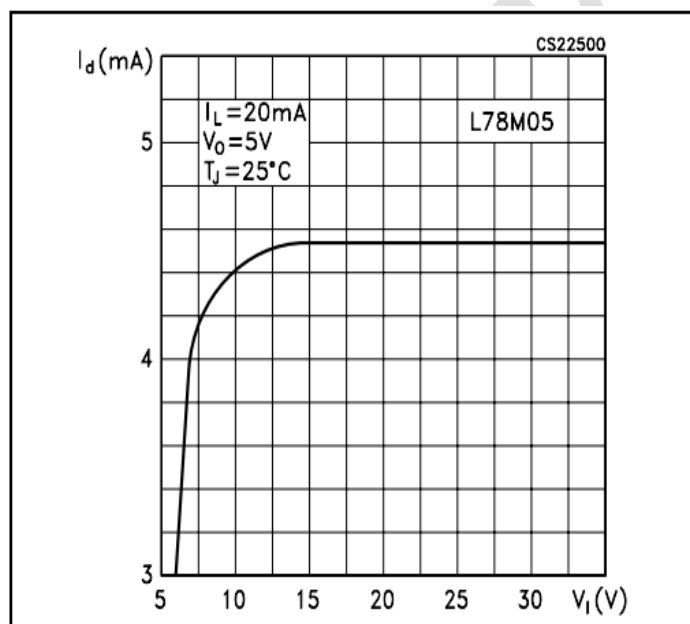

Figure 16. Quiescent current vs. input voltage



7 Applications information

7.1 Design considerations

The L78MxxA series of fixed voltage regulators are designed with thermal overload protection that shuts down the circuit when subjected to an excessive power overload condition, internal short-circuit protection that limits the maximum current the circuit will pass, and output transistor safe-area compensation that reduces the output short-circuit as the voltage across the pass transistor is increased. In many low current applications, compensation capacitors are not required. However, it is recommended that the regulator input be bypassed with a capacitor if the regulator is connected to the power supply filter with long wire lengths, or if the output load capacitance is large. An input bypass capacitor should be selected to provide good high-frequency characteristics to insure stable operation under all load conditions. A 0.33 μF or larger tantalum, mylar, or other capacitor having low internal impedance at high frequencies should be chosen. The bypass capacitor should be mounted with the shortest possible leads directly across the regulators input terminals. Normally good construction techniques should be used to minimize ground loops and lead resistance drops since the regulator has no external sense lead.

Figure 17. Current regulator

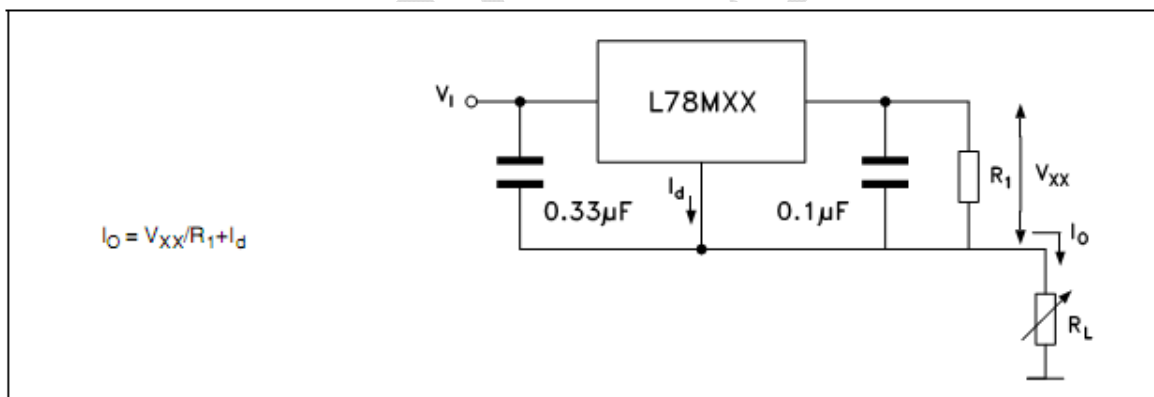

Figure 18. Adjustable output regulator

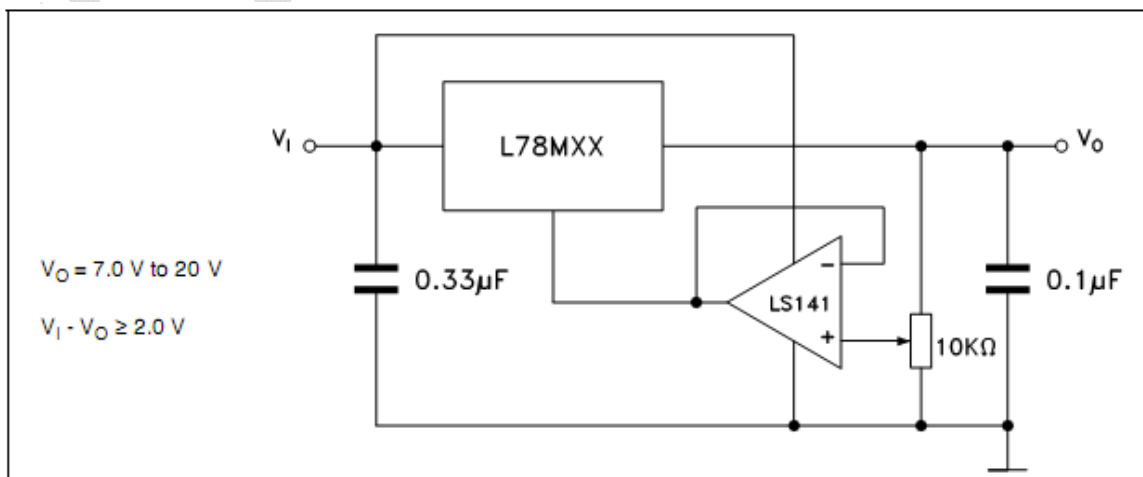

Figure 19. Current boost regulator

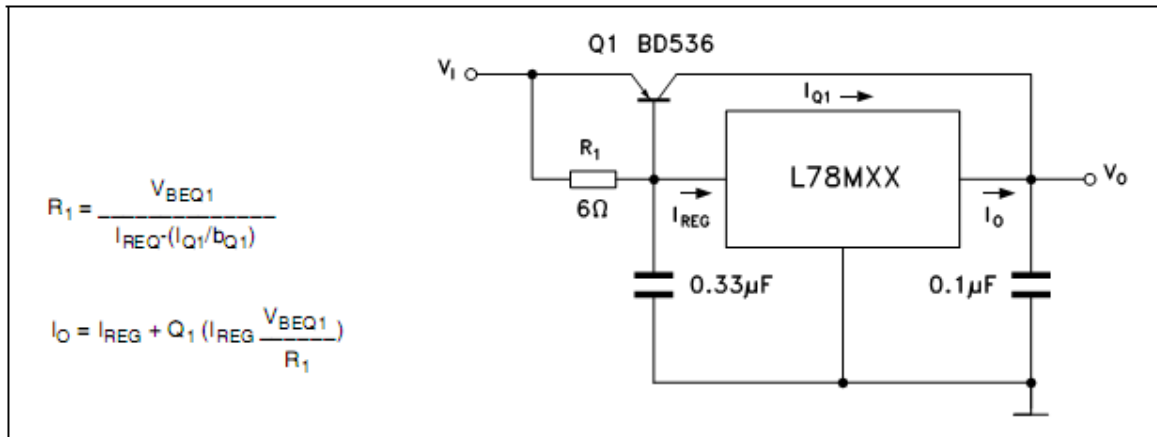
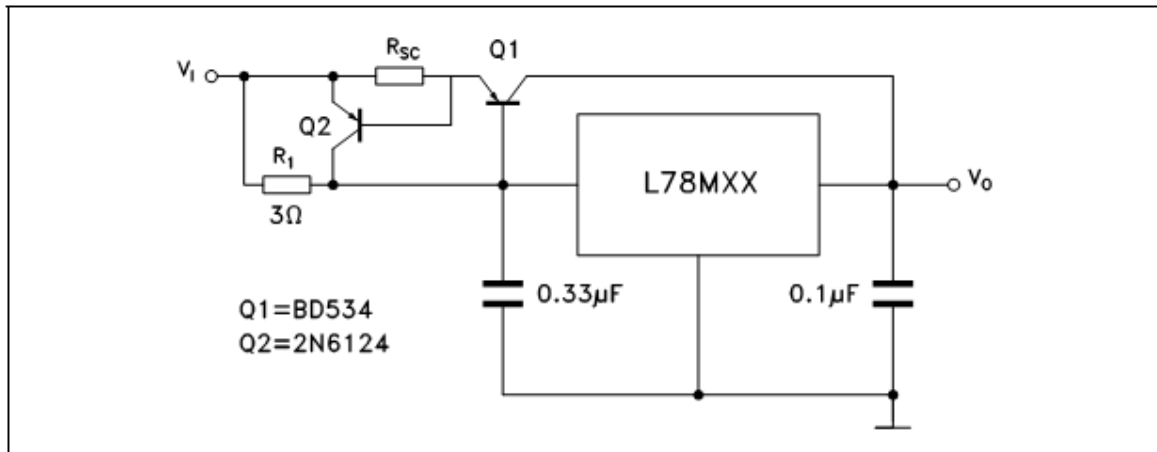

Figure 20. Short-circuit protection



Note: The circuit of Figure 19 can be modified to provide supply protection against short-circuits by adding a short-circuit sense resistor, R_{SC}, and an additional PNP transistor. The current sensing PNP must be able to handle the short-circuit current of the three-terminal regulator. Therefore, a four ampere plastic power transistor is specified.

8 Package mechanical data

TO-220 mechanical data

DIM.	mm.			inch		
	MIN.	TYP	MAX.	MIN.	TYP	MAX.
A	4.40		4.60	0.173		0.181
C	1.23		1.32	0.048		0.051
D	2.40		2.72	0.094		0.107
D1		1.27			0.050	
E	0.49		0.70	0.019		0.027
F	0.61		0.88	0.024		0.034
F1	1.14		1.70	0.044		0.067
F2	1.14		1.70	0.044		0.067
G	4.95		5.15	0.194		0.203
G1	2.4		2.7	0.094		0.106
H2	10.0		10.40	0.393		0.409
L2		16.4			0.645	
L4	13.0		14.0	0.511		0.551
L5	2.65		2.95	0.104		0.116
L6	15.25		15.75	0.600		0.620
L7	6.2		6.6	0.244		0.260
L9	3.5		3.93	0.137		0.154
DIA.	3.75		3.85	0.147		0.151

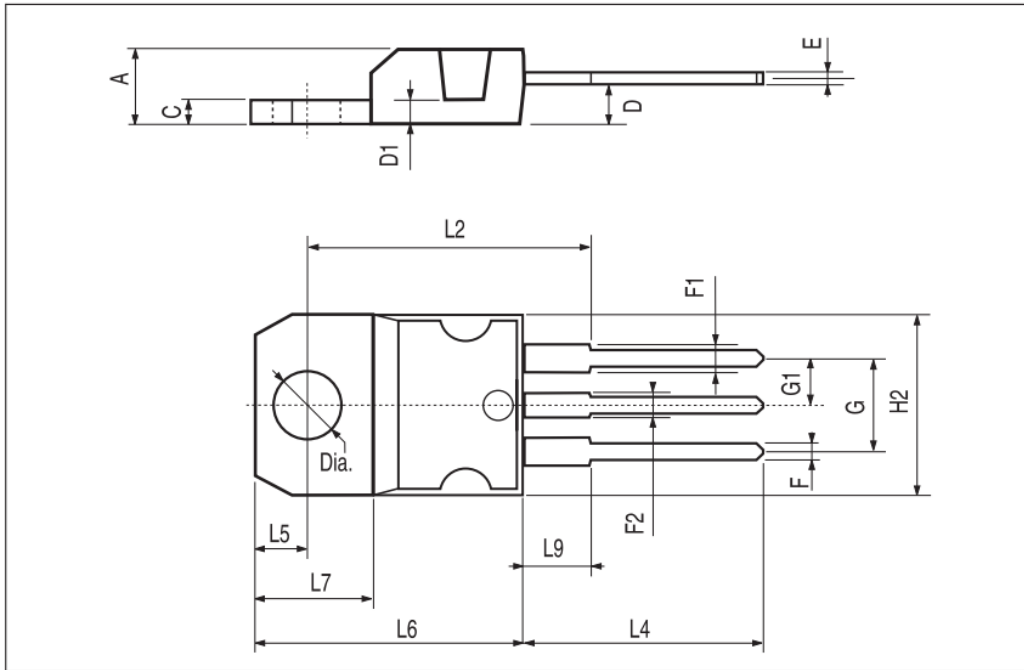

Figure 21. Drawing dimension DPAK

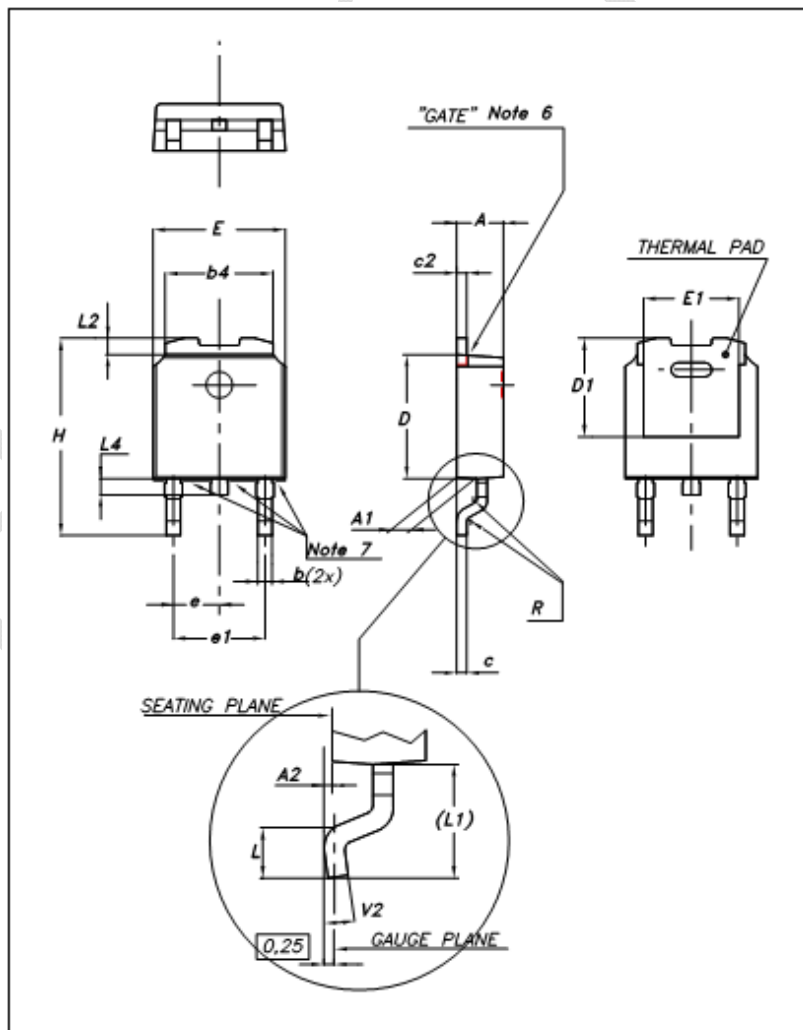

Table 12. DPAK mechanical data

Dim.	Values		
	mm.		
	Min.	Typ.	Max.
A	2.19		2.38
A1	0.89		1.14
A2	0.03		0.23
b	0.64		0.88
b4	5.21		5.46
c	0.46		0.58
c2	0.46		0.58
D	5.97		6.22
D1		5.20	
E	6.35		6.73
E1		4.70	
e		2.28	
e1	4.51		4.61
H	9.40		10.42
L	0.90		
L1	2.50		2.65
L2	0.89		1.27
L4	0.64		1.02
R		0.20	
V2	0°		8°

Figure 24. DPAK footprint recommended data

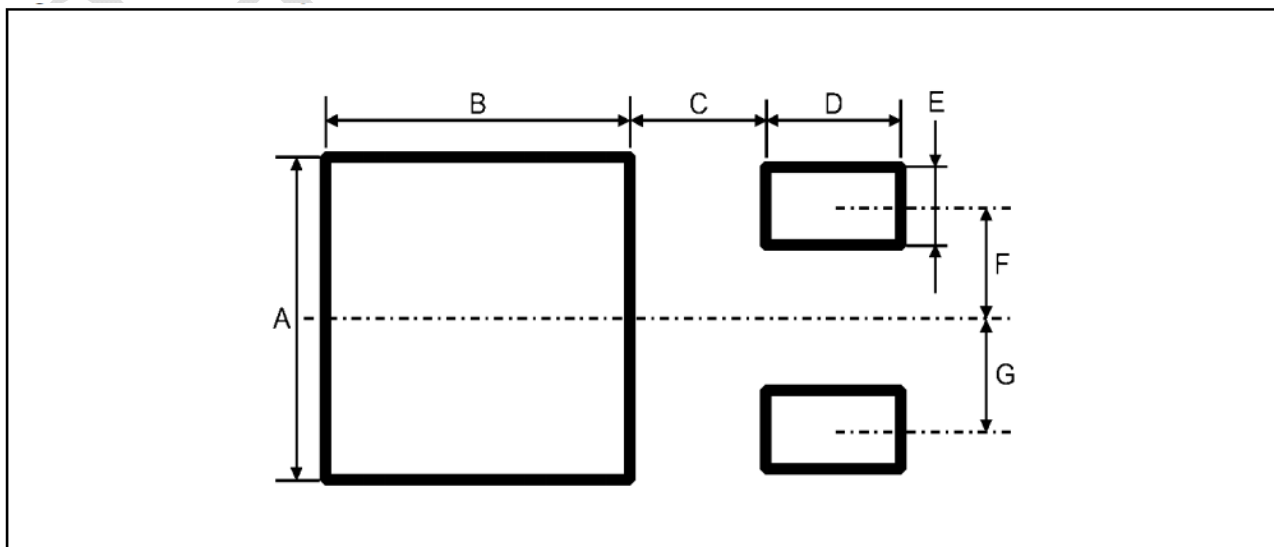
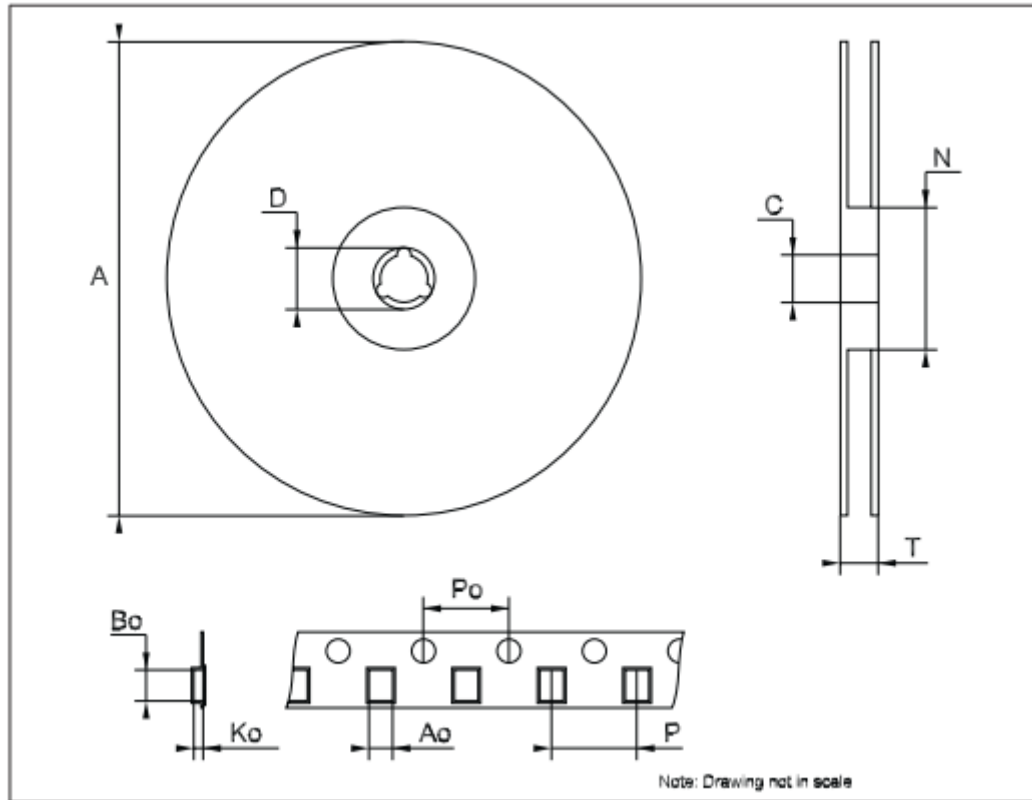

Table 13. Footprint data

Dim.	Values	
	mm.	inch
A	6.70	0.264
B	6.70	0.64
C	1.8	0.070
D	3.0	0.118
E	1.60	0.063
F	2.30	0.091
G	2.30	0.091

Tape & reel DPAK-PPAK mechanical data

DIM.	mm.			Inch.		
	MIN.	TYP	MAX.	MIN.	TYP	MAX.
A			330			12.992
C	12.8	13.0	13.2	0.504	0.512	0.519
D	20.2			0.795		
N	60			2.362		
T			22.4			0.882
A ₀	6.80	6.90	7.00	0.268	0.272	0.276
B ₀	10.40	10.50	10.60	0.409	0.413	0.417
K ₀	2.55	2.65	2.75	0.100	0.104	0.105
P ₀	3.9	4.0	4.1	0.153	0.157	0.161
P	7.9	8.0	8.1	0.311	0.315	0.319



9 Order codes

Table 14. Order codes

Part numbers	Packaging		
	TO-220	DPAK	Output voltages
L78M05AB	L78M05ABV	L78M05ABDT-TR	5 V
L78M05AC		L78M05ACDT-TR	5 V
L78M06AB		L78M06ABDT-TR	6 V
L78M08AB		L78M08ABDT-TR	8 V
L78M09AB		L78M09ABDT-TR	9 V
L78M10AB		L78M10ABDT-TR	10 V
L78M12AB	L78M12ABV	L78M12ABDT-TR	12 V
L78M12AC		L78M12ACDT-TR	12 V
L78M15AB	L78M15ABV	L78M15ABDT-TR	15 V
L78M24AB		L78M24ABDT-TR	24 V
L78M24AC		L78M24ACDT-TR	24 V

Copyright © 2008 by HOTCHIP TECHNOLOGY CO., LTD.

The information appearing in this Data Sheet is believed to be accurate at the time of publication. However, HOTCHIP assumes no responsibility arising from the use of the specifications described. The applications mentioned herein are used solely for the purpose of illustration and HOTCHIP makes no warranty or representation that such applications will be suitable without further modification, nor recommends the use of its products for application that may present a risk to human life due to malfunction or otherwise. HOTCHIP's products are not authorized for use as critical components in life support devices or systems. HOTCHIP reserves the right to alter its products without prior notification. For the most up-to-date information, please visit our web site at <http://www.hotchip.com.cn>.