



L8312

LINEAR INTEGRATED CIRCUIT

DUAL POLARIZATION AND TONE SWITCH CONTROLLER

DESCRIPTION

The UTC **L8312** is specially designed integrated circuit for control satellite receiver front-end block switch and provides customers with dual independent channel of two-control signal: polarization and tone switch controller for LNB switch signal path selection.

The UTC **L8312** is characterized by its two independent channels and each provides logical outputs to show status of LNB switch polarization selection and 22 KHz tone signal.

Minimum number of external discrete components and the wide range of supply voltage make this device suitable in Twin, Quad and multiple feed universal LNB switch to get lower cost and minimum PCB size.

In order to satisfy the special LNB switch model, a tighter specification has been taken into consideration for the polarization switch characteristics. The number of external components is also reduced. The UTC **L8312** includes separate 22K tone detection for each channel. In addition, the built-in tone amplifier circuit is designed to protect transient signal by an external resistor and capacitor simply, and it also provides good bandwidth and sensitivity.

The UTC **L8312** is generally applied in multi output LNB and multi switch.

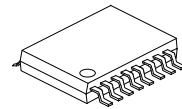

SSOP-16

FEATURES

- * Direct Drive PIN Diode and Multiplexer IC
- * High Supply Voltage

ORDERING INFORMATION

Ordering Number		Package	Packing
Lead Free	Halogen Free		
L8312L-R16-R	L8312G-R16-R	SSOP-16	Tape Reel

<p>L8312G-R16-R</p> <ul style="list-style-type: none"> (1) Packing Type (2) Package Type (3) Green Package 	<ul style="list-style-type: none"> (1) R: Tape Reel (2) R16: SSOP-16 (3) G: Halogen Free and Lead Free, L: Lead Free
---	---

MARKING

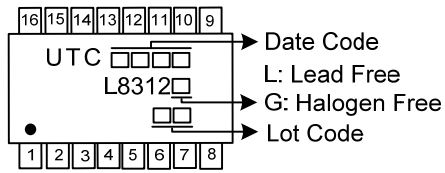

■ PIN CONFIGURATION

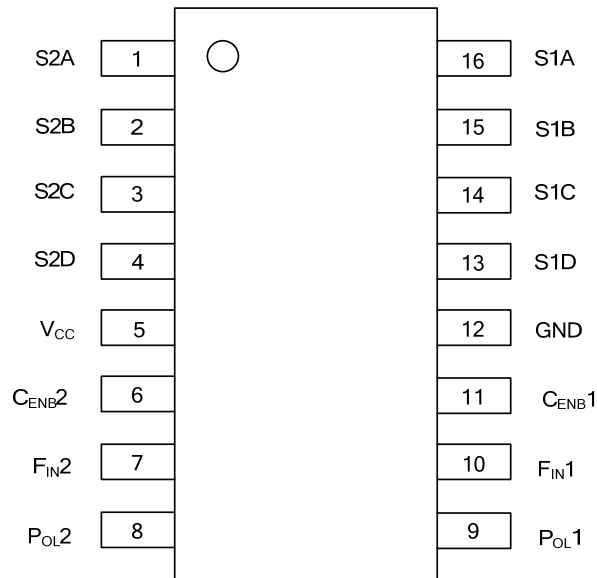

■ PIN DESCRIPTION

PIN NO.	PIN NAME	DESCRIPTION
1	S2A	Channel 2 Switch Output A
2	S2B	Channel 2 Switch Output B
3	S2C	Channel 2 Switch Output C
4	S2D	Channel 2 Switch Output D
5	V _{CC}	Supply Voltage Pin
6	C _{ENB2}	Channel 2 Enable
7	F _{IN2}	Channel 2 22KHz Tone Input Pin
8	P _{OL2}	Channel 2 Polarization Input Pin
9	P _{OL1}	Channel 1 Polarization Input Pin
10	F _{IN1}	Channel 1 22KHz Tone Input Pin
11	C _{ENB1}	Channel 1 Enable
12	GND	Ground Pin
13	S1D	Channel 1 Switch Output A
14	S1C	Channel 1 Switch Output B
15	S1B	Channel 1 Switch Output C
16	S1A	Channel 1 Switch Output D

■ BLOCK DIAGRAM

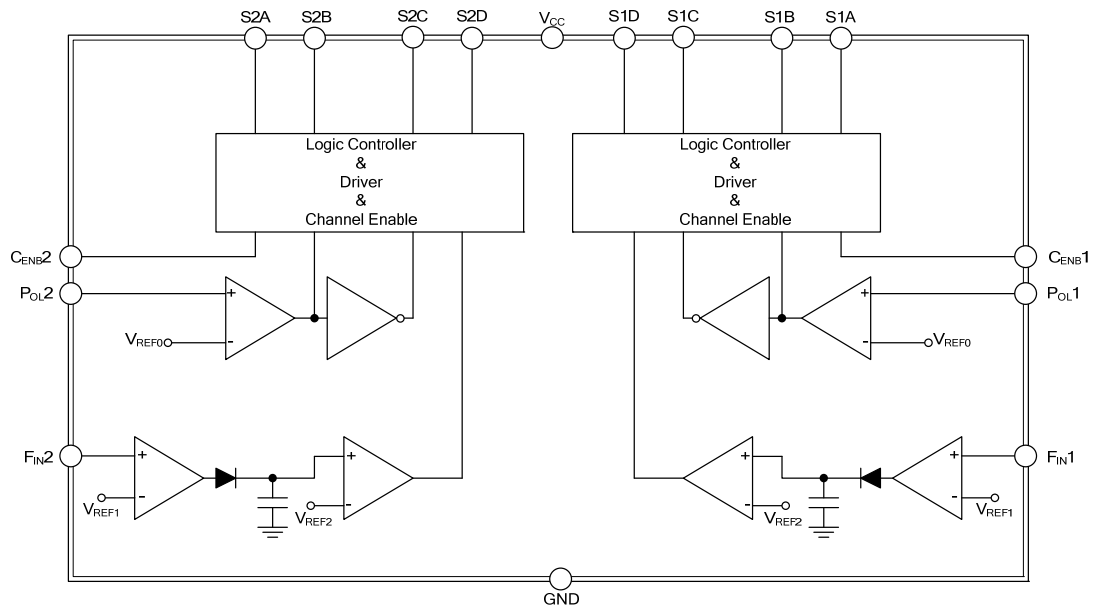

■ ABSOLUTE MAXIMUM RATING ($T_A = -25 \sim +85^\circ\text{C}$, unless otherwise specified)

PARAMETER	SYMBOL	RATINGS	UNIT
Supply Voltage	V_S	-0.6 ~ 12	V
Supply Current	I_S	100	mA
Input Voltage (P_{OL} Pin)	V_{IN}	25	V
Power Dissipation ($T_A = 25^\circ\text{C}$)	P_D	600	mW
Operating Junction Temperature	T_J	-40 ~ 70	$^\circ\text{C}$
Storage Temperature	T_{STG}	-50 ~ 85	$^\circ\text{C}$

Note: Absolute maximum ratings are those values beyond which the device could be permanently damaged. Absolute maximum ratings are stress ratings only and functional device operation is not implied.

■ ELECTRICAL CHARACTERISTICS ($V_{CC} = 5\text{V}$, $T_A = 25^\circ\text{C}$, unless otherwise specified)

PARAMETER	SYMBOL	TEST CONDITIONS	MIN	TYP	MAX	UNIT
Supply Voltage ($T_{OPR} = -40^\circ\text{C} \sim 80^\circ\text{C}$)	V_{CC}		5		9	V
Supply Current	I_{CC}	Standby current, no load		10		mA
Output Voltage High	SW_{HIGH}	$I_{SW} = -5\text{mA}$	$V_{CC} - 1.0$	$V_{CC} - 0.9$	V_{CC}	V
Output Voltage Low	SW_{LOW}	$I_{SW} = 5\text{mA}$	0	0.3	0.5	V
tone/polarity switch characteristics						
Tone Switch Threshold	V_{TST}	Coupling via 10nF(sin wave)	100	170	350	mV _{PP}
Low Frequency Rejection	f_{RL}	Coupling via 10nF(sin wave)	1.0	7.5		KHz
Polarity Detector Input Current	I_{POL}	V_{POL1} , 2 input=25V, via $R_{POL} = 1\text{K}\Omega$	100	130	200	μA
Polarity Detector Threshold Voltage	V_{TPOL}	V_{POL1} , 2 input applied via $R_{POL} = 1\text{K}\Omega$	14.0	14.5	15.0	V
Switching Speed	T_S	V_{POL1} , 2 input applied via $R_{POL} = 1\text{K}\Omega$			100	ms
Enable Threshold Voltage	V_{ENB}	$I_{CENB} = -50\mu\text{A}$	0.7	1.2	1.5	V

■ TYPICAL APPLICATION CIRCUIT

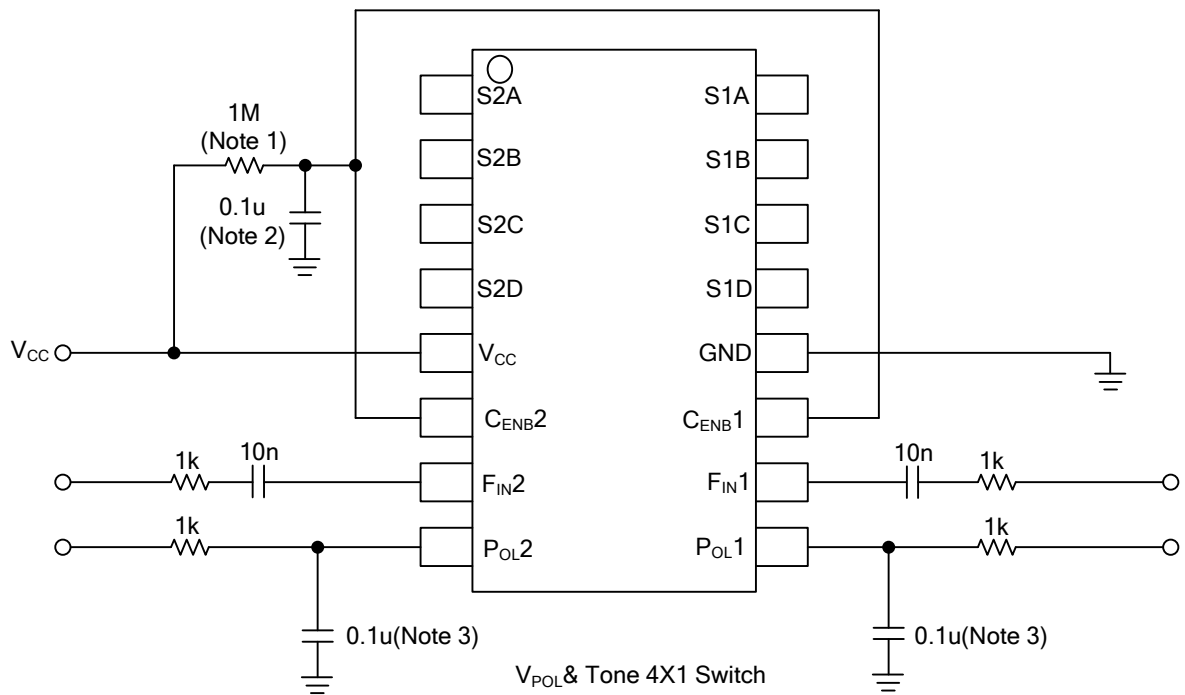

Note:1. Current limitation resistance

2. Required BYPASS capacitor for noise interference elimination

3. Optional BYPASS capacitor for 22KHz tone interference elimination

■ FUNCTIONAL INFORMATION

The UTC **L8312** is specially designed integrated circuit for control satellite receiver front-end block switch, it contains all the circuits necessary to detect the DC voltage and 22KHz signal on the supply input to the LNB switch.

The tone switch circuit incorporates an operational amplifier used as active filter, a rectifier /a comparator and an output driver. Built-in feedback resistor included in operational amplifier, external component counts are thus minimized. Therefore, low pass filter response can be achieved with a simple external RC.

The gain of operational amplifier must be adjusted with different supply voltage due to the threshold of comparator is supply dependent. To optimize the system performance, the external RC values must be adjusted. The resistor also provides maximum input voltage protection for the P_{POL}1, 2 pins. The low pass filter of tone detection circuit allows the UTC **L8312** to reliably detect tone signal. Each channel decodes tone polarization signals to activate one of four outputs. Each of those outputs has the capability of sinking 5mA and sourcing 5mA, providing the capability of driving directly signal routing pin diodes.

In addition, the channel outputs would activate when pins voltage of C_{ENB}1, 2 set high, which means, C_{ENB}1, 2 pins input signal have priority over tone polarization signals to control channel outputs.

Table 1 shows the logical output truth table.

Table1

C _{ENB} 1	Tone	V _{POL}	S1A	S1B	S1C	S1D
≤ 0.7V			Low	Low	Low	Low
≥ 1.2V		< 9.5V	Low	Low	Low	Low
≥ 1.2V	Off	≤ 14V	High	Low	Low	Low
≥ 1.2V	Off	≥ 15.5V	Low	High	Low	Low
≥ 1.2V	On	≤ 14V	Low	Low	High	Low
≥ 1.2V	On	≥ 15.5V	Low	Low	Low	High

C _{ENB} 2	Tone	V _{POL}	S2A	S2B	S2C	S2D
≤ 0.7V			Low	Low	Low	Low
≥ 1.2V		< 9.5V	Low	Low	Low	Low
≥ 1.2V	Off	≤ 14V	High	Low	Low	Low
≥ 1.2V	Off	≥ 15.5V	Low	High	Low	Low
≥ 1.2V	On	≤ 14V	Low	Low	High	Low
≥ 1.2V	On	≥ 15.5V	Low	Low	Low	High

UTC assumes no responsibility for equipment failures that result from using products at values that exceed, even momentarily, rated values (such as maximum ratings, operating condition ranges, or other parameters) listed in products specifications of any and all UTC products described or contained herein. UTC products are not designed for use in life support appliances, devices or systems where malfunction of these products can be reasonably expected to result in personal injury. Reproduction in whole or in part is prohibited without the prior written consent of the copyright owner. UTC reserves the right to make changes to information published in this document, including without limitation specifications and product descriptions, at any time and without notice. This document supersedes and replaces all information supplied prior to the publication hereof.