

36V, 2A, 520KHz, Synchronous, Step-Down Converter

LA1412

Overview

The LA1412 is an easy to use synchronous step-down Buck. Which integrated low on resistance high-side and low-side power MOSFETs. The LA1412 can deliver 2A of output current efficiently with constant on time (COT) control for fast loop response.

The LA1412 achieves high power conversion efficiency over a wide load range by scaling down the switching frequency under light-load conditions to reduce switching and gate driving losses.

The LA1412 has built-in protection features, such as cycle-by-cycle current limit, hiccup mode short-circuit protection, FB open short protection and thermal shutdown in case of excessive power dissipation. The LA1412 is available in a space-saving SOT23-6L package.

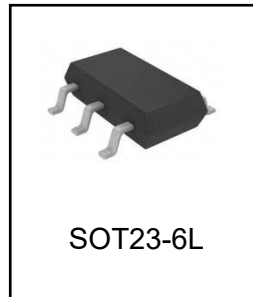

Features

- 4.5V to 36V Wide Input Range
- 2A Continuous Output Current
- 135mΩ/85mΩ Internal Power MOSFETs
- Constant On Time Control for Fast Loop Response
- 520KHz Switching Frequency
- Pulse Frequency Modulation at Light Load
- Support Up to 98% Large Range Duty Cycle
- Internal Soft Start
- Output Voltage Adjustable from 0.6V
- Support Pre-Biased Output Startup
- Full Protection, Over Current Protection and Hiccup, Output Over Voltage Protection, FB Open Short Protection, Over Temperature Protection
- Available in a SOT23-6L Package

Applications

- Surveillance Camera
- Home Appliance and Whitegoods
- Multi-functional Printer
- Automotive
- Industrial Control

Typical Application

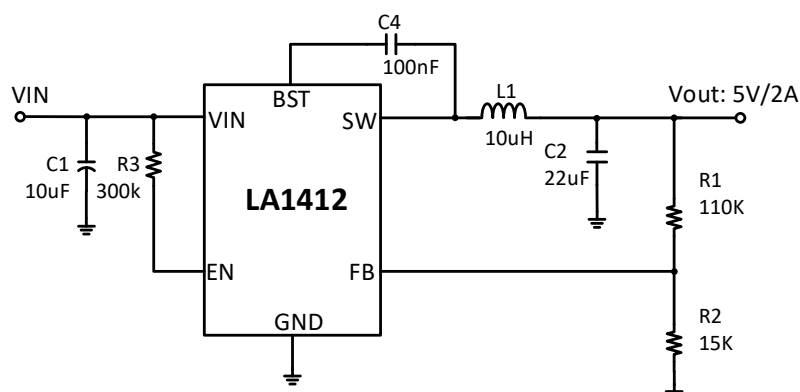

Package Mark and Order Information

Device	Package	Temperature range	Packaging Type	Purchase Contact
LA1412	SOT23-6L	-40 to 150°C	T/R 3000pcs/roll	sales@latticeart.com

Pin Diagram

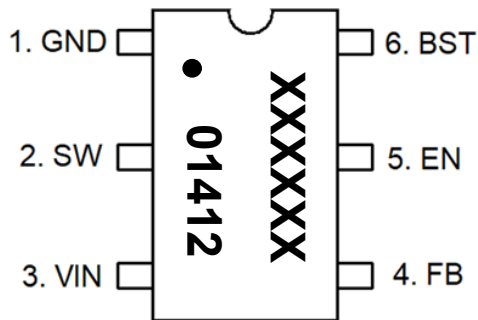

XXXXXX: Lot number
01412: Product code

Pin Description

Pin No.	Symbol	Pin Description
1	GND	Power Ground terminal.
2	SW	Switching output of the convertor. Internally connected to source of the high-side FET and drain of the low-side FET. Connect to power inductor.
3	VIN	Supply input terminal to internal bias LDO and high-side FET. Connect to input supply and input bypass capacitors CIN. Input bypass capacitors must be directly connected to this pin and GND.
4	FB	Feedback input to the convertor. Connect a resistor divider to set the output voltage. Never short this terminal to ground during operation.
5	EN	Precision enable input to the convertor. Do not float. High = on, Low = off. Can be tied to VIN by a resistor. Precision enable input allows adjustable UVLO by external resistor divider.
6	BST	Bootstrap capacitor connection for high-side FET driver. Connect a high quality 100nF capacitor from this pin to the SW pin.



Block Diagram

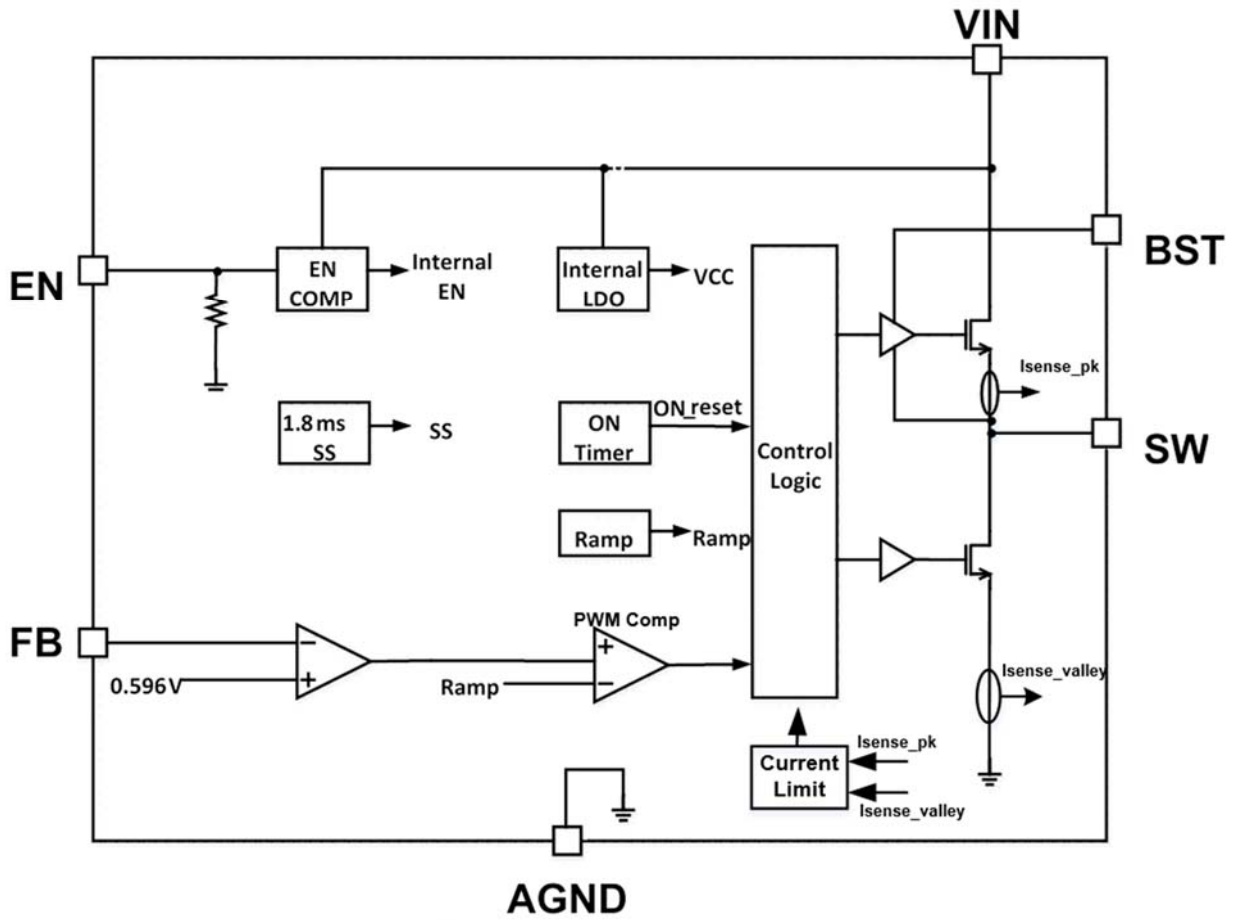

Absolute Maximum Ratings (Note 1)

$T_A=25^{\circ}\text{C}$, unless otherwise specified.

Symbol	Definition	Ratings	Unit
V_{IN}	VIN to GND	-0.3~38	V
SW	SW to GND	-0.7 (-5V in 10ns)~VIN + 0.7	V
EN	Max Input current to EN pin	100 ⁽²⁾	uA
BST	BST to SW	-0.3~6	V
All Other Pins		-0.3~6	V
T_{STG}	Storage temperature	-55 to 150	$^{\circ}\text{C}$
T_j	Junction temperature	-40 to 150	$^{\circ}\text{C}$

Note 1: Stresses beyond those listed under “absolute maximum ratings” may cause permanent damage to the device. These are not tested at manufacturing.

Note 2: For details on ENs ABS max rating, please refer to the Enable Control section.

Recommended Operating Conditions

Symbol	Definition	Ratings	Unit
BST	BST to SW	4~5	V
FB	FB to GND	0~1	V
EN	EN to GND	0~5	V
V_{IN}	VIN to GND	4.5~36	V
V_{OUT}	V_{OUT} to GND	0.6~VIN* $D_{MAX}^{(3)}$ or 13V	V
I_{OUT}	Max Continuous Output Current	2	A

Note 3: $D_{MAX} = T_{ON_MAX} / (T_{ON_MAX} + T_{OFF_MIN})$. Typical value is 98%.

Thermal Resistance (Note 4)

Symbol	Definition	Ratings	Unit
$R_{\theta JC}$	Junction to case thermal resistance	21	$^{\circ}\text{C}/\text{W}$
$R_{\theta JA}$	Junction to ambient thermal resistance	40	$^{\circ}\text{C}/\text{W}$

Note 4: Measured on EV1412-00B 2-Layer PCB.

ESD Rating

Symbol	Definition	Ratings	Unit
HBM	Human body model	± 2000	V
CDM	Changed device model	± 500	V

Electrical Characteristics

$V_{IN}=12V$, $V_{EN}=2V$, $T_A=25^{\circ}C$, unless otherwise specified.

Symbol	Parameter	Condition	Min	Typ	Max	Units
$V_{IN_{UVR}}$	VIN UVLO rising threshold		4.1	4.25	4.4	V
$V_{IN_{UVF}}$	VIN UVLO falling threshold		3.85	4.0	4.15	V
$V_{IN_{UV_hys}}$	VIN UVLO hysteresis			0.25		V
I_{QS}	Shutdown supply current	$V_{EN} < 0.3V$, $V_{IN}=12V$		1	3	μA
I_Q	Quiescent supply current	No load, $V_{FB} = 0.83V$, no switching		160		μA
LK_{HS}	High-side leakage	$V_{EN} = 0V$, $V_{SW} = 0V$			1	μA
LK_{LS}	Low-side leakage	$V_{EN} = 0V$, $V_{SW} = 12V$			1	μA
V_{FB}	Feedback voltage	$T_A=25^{\circ}C$	584	596	608	mV
		$T_A=-40^{\circ}C \sim 125^{\circ}C$	581	596	611	mV
FB_{UVP}	Hiccup threshold			280		mV
I_{LK_FB}	Feedback leakage	$V_{EN} = 1V$, $V_{FB} = 2V$			0.1	μA
R_{ON_HS}	High-side switch on resistance	$V_{BST} - V_{SW} = 5V$		135		m Ω
R_{ON_LS}	Low-side switch on resistance	$V_{IN} = 12V$		85		m Ω
I_{LIM_LS}	Low-side Current limit	$T_A=-40^{\circ}C \sim 125^{\circ}C$	2.3	2.9	3.5	A
I_{LIM_HS}	High-side Current limit	$T_A=-40^{\circ}C \sim 125^{\circ}C$	3.6	4.8	5.8	A
I_{LIM_ZCD}	Zero Crossing			100		mA
T_{SS}	Soft-start time	V_{FB} from 0% to 100%		1.8		ms
F_{SW}	Oscillator frequency		440	520	600	KHz
$T_{ONMIN}^{(5)}$	Minimum switch on time			80		nS
$T_{OFFMIN}^{(5)}$	Minimum switch off time			120		nS
D_{MAX}	Max duty cycle			98%		%
V_{EN_R}	Enable rising threshold	Low to high	1.1	1.2	1.3	V
V_{EN_F}	Enable falling threshold	High to low	0.8	0.9	1.0	V
V_{EN_Hys}	Enable Threshold Hysteresis			0.2		V
R_{EN}	Enable input resistor.			1500		k Ω
$T_{OTP_R}^{(5)}$	Thermal shutdown			150		$^{\circ}C$
$T_{OTP_Hys}^{(5)}$	OTP hysteresis			20		$^{\circ}C$

Note 5: Guaranteed by design



Typical Performance Characteristic

$V_{OUT}=5V$; $V_{IN} = 12V$, $C1 = 10\mu F$, $C2 = 22\mu F$, $L1 = 10\mu H$, and $T_A = +25^\circ C$, unless otherwise noted.

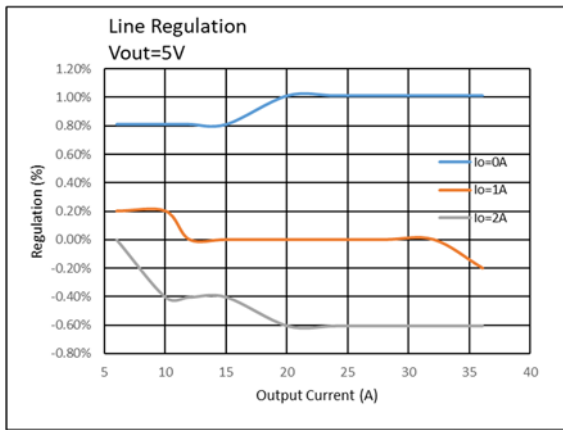
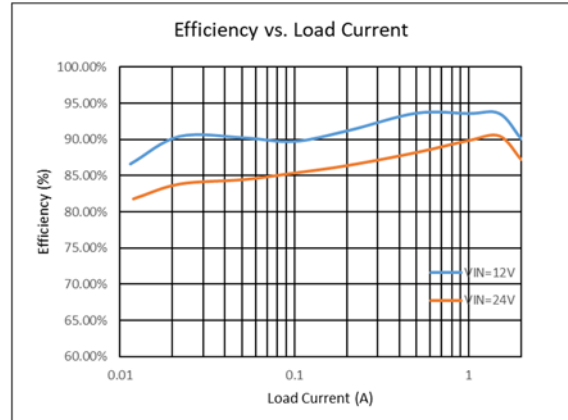
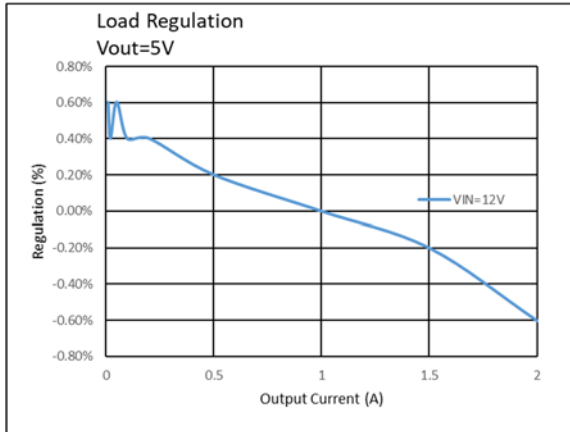

Typical Performance Characteristic (continued)

$V_{IN} = 12V$, $V_{OUT} = 5V$, $C1 = 10\mu F$, $C2 = 22\mu F$, $L1 = 10\mu H$, and $T_A = +25^\circ C$, unless otherwise noted.

Output Voltage Ripple

$I_{OUT} = 0A$

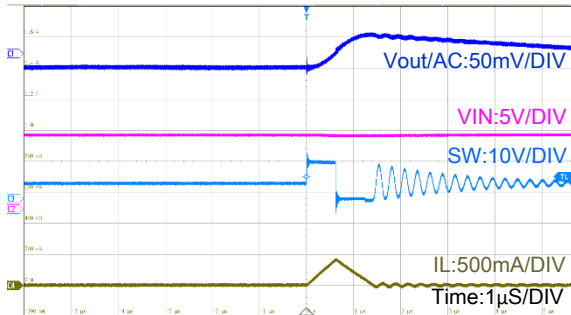

Output Voltage Ripple

$I_{OUT} = 2A$

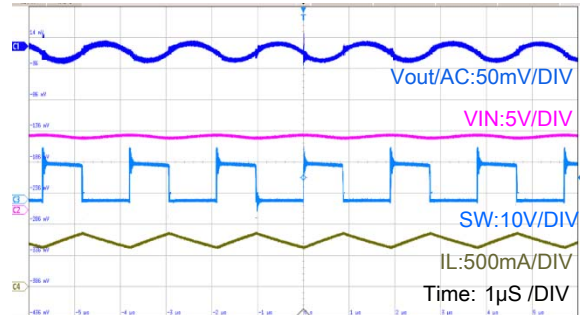

Start-Up through V_{IN}

$I_{OUT} = 0A$

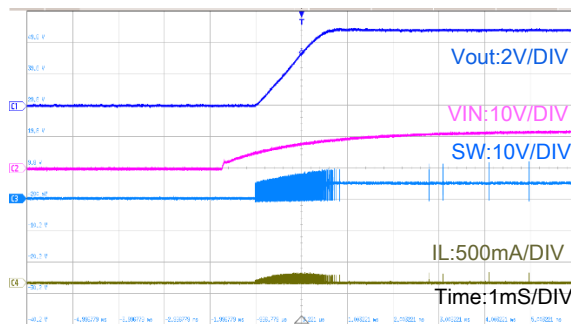

Start-Up through V_{IN}

$I_{OUT} = 2A$

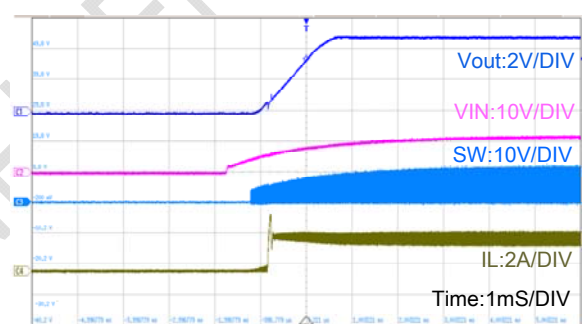

Shut-Down through V_{IN}

$I_{OUT} = 0A$

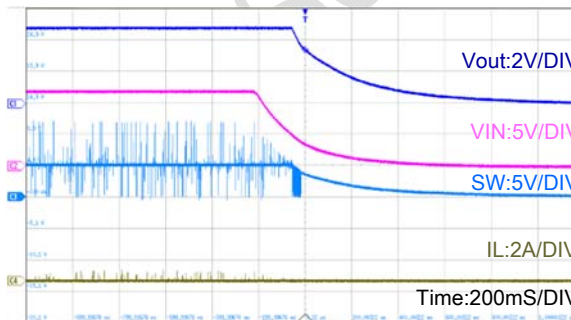

Shut-Down through V_{IN}

$I_{OUT} = 2A$

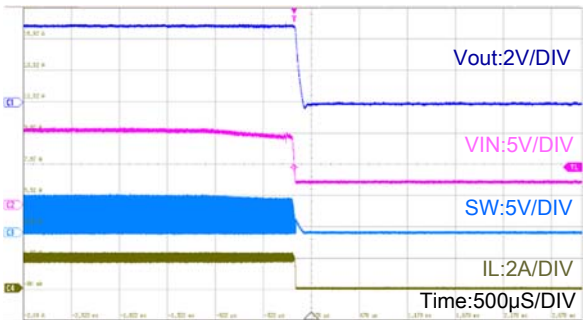



Typical Performance Characteristic (continued)

$V_{IN} = 12V$, $V_{OUT} = 5V$, $C1 = 10\mu F$, $C2 = 22\mu F$, $L1 = 10\mu H$, and $T_A = +25^\circ C$, unless otherwise noted.

Start-Up through EN

IOUT = 0A

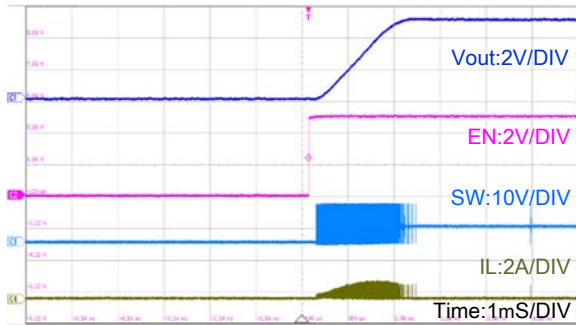

Start-Up through EN

IOUT = 2A

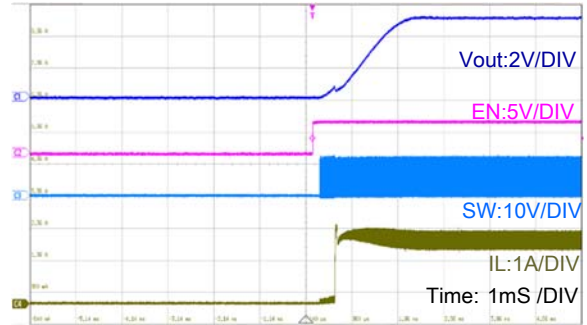

Shutdown-Down through EN

IOUT = 0A

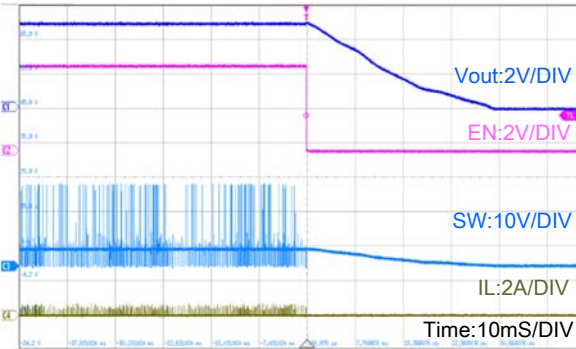

Shutdown-Down through EN

IOUT = 2A

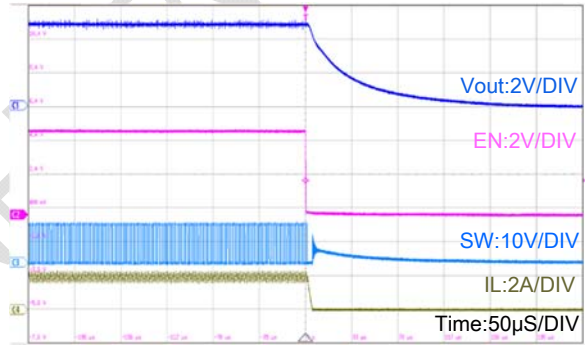

Short-Circuit Entry

IOUT = 0A

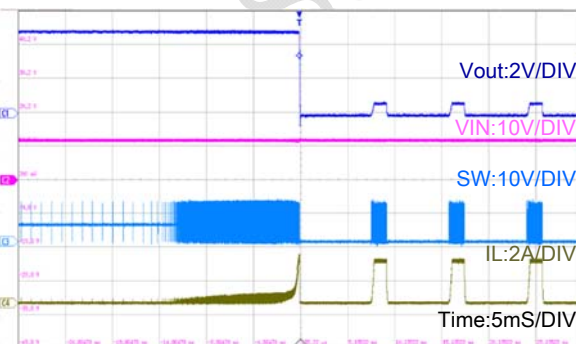

Short-Circuit Recovery

IOUT = 0A

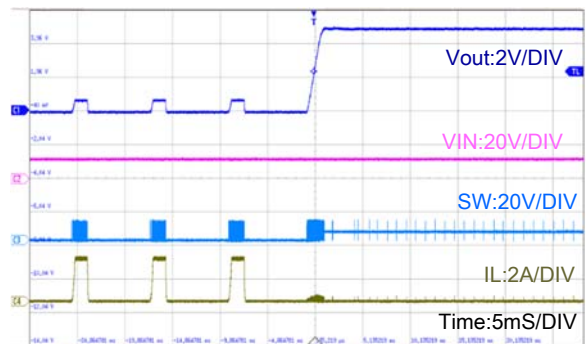

Typical Performance Characteristic *(continued)*

$V_{IN} = 12V$, $V_{OUT} = 5V$, $C1 = 10\mu F$, $C2 = 22\mu F$, $L1 = 10\mu H$, and $T_A = +25^\circ C$, unless otherwise noted.

Load Transient

$I_{OUT} = 1A$ to $2A$, 2 pcs $22\mu F$ C_{out} , $2.5A/\mu s$ slew rate

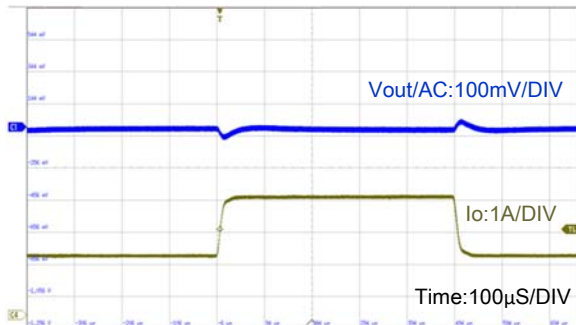

LA Semi CONFIDENTIAL

Function Descriptions

Pulse-Width Modulation (PWM) Control

The LA1412 is fully integrated synchronous rectified step-down switch mode converter. Constant-on-time (COT) control is employed to provide fast transient response and easy loop stabilization. At the beginning of each cycle, the high-side MOSFET (HS-FET) is turned ON when the feedback voltage (VFB) is below the reference voltage (VREF), which indicates insufficient output voltage. The ON period is determined by both the output voltage and input voltage to make the switching frequency fairly constant over input voltage range.

After the ON period elapses, the HS-FET is turned off, or becomes OFF state. It is turned ON again when VFB drops below VREF. By repeating operation this way, the converter regulates the output voltage. The integrated low-side MOSFET (LS-FET) is turned on when the HS-FET is in its OFF state to minimize the conduction loss. To avoid shoot-through, a dead-time (DT) is internally generated between HS-FET off and LS-FET on, or LS-FET off and HS-FET on.

An internal compensation is applied for COT control to make a more stable operation even when ceramic capacitors are used as output capacitors, this internal compensation will then improve the jitter performance without affect the line or load regulation.

With the load decrease, the inductor current decrease too. Once the inductor current touch zero, the operation is transition from continuous-conduction-mode (CCM) to discontinuous- conduction-mode (DCM).

When the LA1412 works in pulse-frequency modulation (PFM) mode during light-load operation, the LA1412 reduces the switching frequency automatically to maintain high efficiency, and the inductor current drops almost to zero. When the inductor current reaches zero, the low-side will be off. The output capacitors discharge slowly to GND through R1 and R2. When VFB drops below the reference voltage, the HS-FET is turned on again. This operation improves device efficiency greatly when the output current is low.

Enable (EN) Control

Enable (EN) is a digital control pin that turns the regulator on and off. Drive EN high to turn on the regulator. Drive EN low to turn off the regulator. An internal 1.7MΩ resistor from EN to GND allows EN to be floated to shut down the chip. EN is clamped internally using a 6V Zener diode. EN can connected to VIN directly by a resistor.

The EN Pin can connect to VIN by a pull-up resistor, but EN input current need below 100uA. For example, if $V_{IN}=24V$, the $I_{Zener}=(24-6)/R_{PULL-UP}<100\mu A$, So, $R_{PULL-UP}>180K\Omega$.

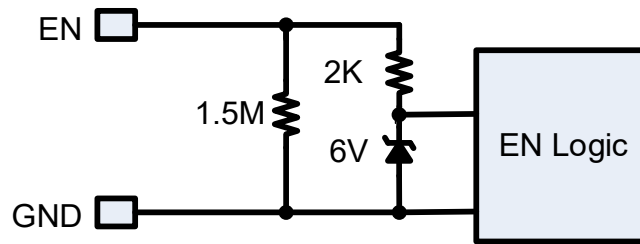

Under-Voltage Lockout (UVLO)

Under-voltage lockout (UVLO) protects the chip from operating at an insufficient supply voltage. The LA1412 UVLO comparator monitors the input voltage. The UVLO rising threshold is about 4.2V, while its falling threshold is consistently 3.9V.

Internal Soft Start (SS)

Soft start (SS) prevents the converter output voltage from overshooting during start-up. When the chip starts, the internal circuitry generates a soft-start voltage (VSS) that ramps up from 0V to 1V. When SS is below REF, SS overrides REF, so the error amplifier uses SS as the reference. When SS exceeds REF, the error amplifier uses REF as the reference. The SS time is set to 1.8ms internally.

Over-Current Protection (OCP) and Short Circuit Protection (SCP)

The LA1412 has a valley current-limit control. During LS-FET on, the inductor current is monitored. If the current is higher than valley current limit, the high side will not turn on again. The output voltage drops until VFB is below the under voltage (UV) threshold (typically 20% below the reference). Once UV is triggered, the LA1412 enters hiccup mode to restart the part periodically.

During OCP, the device attempts to recover from the over-current fault with hiccup mode. In hiccup mode, the chip disables the output power stage, discharges the soft start, and attempts to soft start again automatically. If the over-current condition still holds after the soft start ends, the device repeats this operation cycle until the over-current condition is removed and the output rises back to regulation levels. OCP is a non-latch protection.

Pre-Bias Start-Up

The LA1412 is designed for monotonic start-up into pre-biased loads. If the output is pre-biased to a certain voltage during start-up, the BST voltage is refreshed and charged, and the voltage on the soft start is charged as well. If the BST voltage exceeds its rising threshold voltage and the soft-start voltage exceeds the sensed output voltage at FB, the part works normally.

Output Over-Voltage Protection

The LA1412 has implement output over-voltage protection. If output voltage rises above the regulated voltage, IC will stop switching to avoid the output voltage overshoot.

Input Over-Voltage Protection

The LA1412 has implement the input over voltage protection. IC will stop switching if input



voltage rises above 39V. This will increase the IC robustness against the surge voltage on the input. In the input over-voltage condition when input voltage drops below 38V, IC will restart switching again and output voltage will back to the regulated value after soft start.

Large Duty Cycle Operation

When LA1412 will automatically extend the frequency to support the application when VIN is close to VOUT. The frequency extend circuit will be triggered when Toff min time is reached. The LA1412 can support up to 98% maximum duty cycle.

Thermal Shutdown

Thermal shutdown prevents the chip from operating at exceedingly high temperatures. When the silicon die temperature exceeds 150°C, the entire chip shuts down. When the temperature falls below its lower threshold (typically 130°C), the chip is enabled again.

LA Semi CONFIDENTIAL

Application Information

Setting the Output Voltage

The LA1412 output voltage can be set by the external resistor dividers. The reference voltage is fixed at 0.6V. The feedback network is shown below Figure.

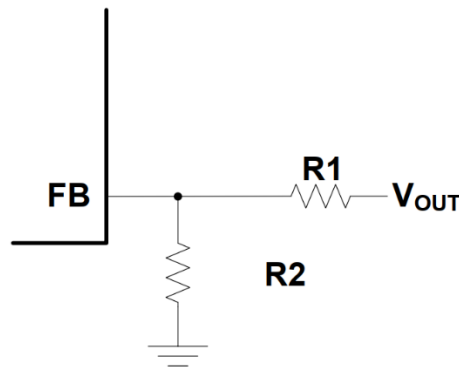

Feedback Network

Choose R_1 and R_2 using Equation:

$$V_{OUT} = V_{FB} (R_1 + R_2) / R_2$$

Selecting the Inductor

For most applications, use a 3.3 μ H to 47 μ H inductor with a DC current rating at least 25% higher than the maximum load current. For the highest efficiency, use an inductor with a small DC resistance.

For most designs, the inductance value can be derived from Equation:

$$L = \frac{V_{OUT} * (V_{IN} - V_{OUT})}{V_{IN} * \Delta I_L * F_{OSC}}$$

Where ΔI_L is the inductor ripple current.

Choose the inductor ripple current to be approximately 30% of the maximum load current. The maximum inductor peak current can be calculated with Equation:

$$I_{L(MAX)} = I_{LOAD} + \frac{\Delta I_L}{2}$$

Table 1 lists the recommended feedback resistor values for common output voltages.

Table 1: Resistor Selection for Common Output Voltages ⁽⁷⁾

V _{OUT} (V)	R ₁ (k Ω)	R ₂ (k Ω)	L (μ H)	C _{OUT} (μ F)
5	110	15	10	22
3.3	68	15	10	22

Selecting the Output Capacitor

The output capacitor (C2, C3) maintains the DC output voltage ripple. Use ceramic, tantalum, or low-ESR electrolytic capacitors. For best results, use low ESR capacitors to keep the output voltage ripple low. The output voltage ripple can be estimated with Equation:

$$\Delta V_{OUT} = \frac{V_{OUT}}{F_{OSC} * L} * \left(1 - \frac{V_{OUT}}{V_{IN}}\right) * \left(R_{ESR} + \frac{1}{8 * F_{OSC} * C_{OUT}}\right)$$

Where L is the inductor value, and R_{ESR} is the equivalent series resistance (ESR) value of the output capacitor.

The characteristics of the output capacitor also affect the stability of the regulation system. The LA1412 can be optimized for a wide range of capacitance and ESR values.

PCB layout Guidelines

Efficient layout of the switching power supplies is critical for stable operation. For the high frequency switching converter, poor layout design may cause poor line or load regulation and stable issues. For best results, refer to below figure and follow the guidelines below.

- Place the input capacitor as close to VIN and GND as possible.
- Place the external feedback resistors as close to FB as possible.
- Keep the switching node (such as SW, BST) far away from the feedback network.
- Add a grid of thermal vias under the exposed pad to improve thermal conductivity.

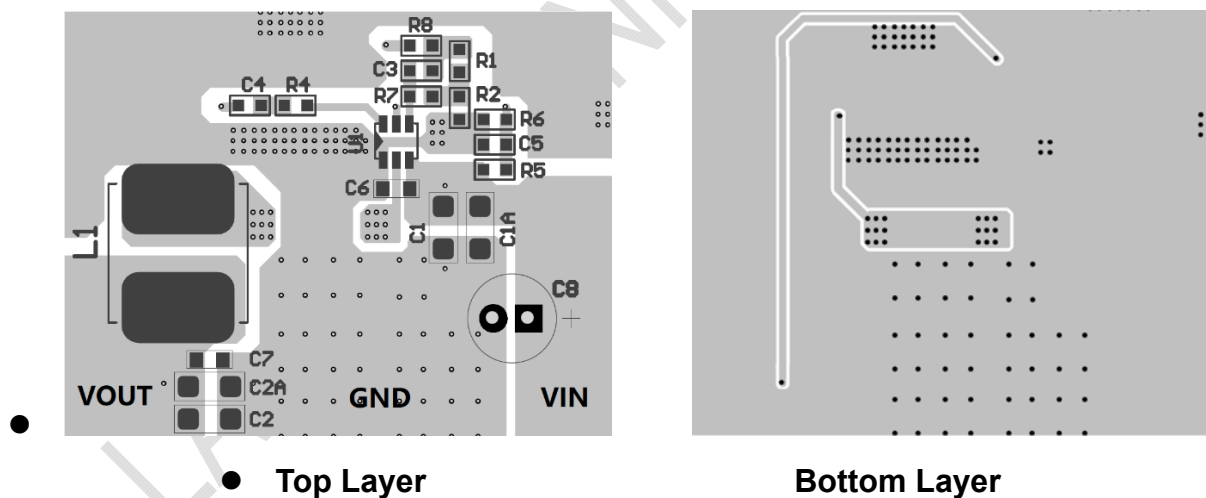

● Figure 3 Recommend PCB Layout



Typical Application Circuits

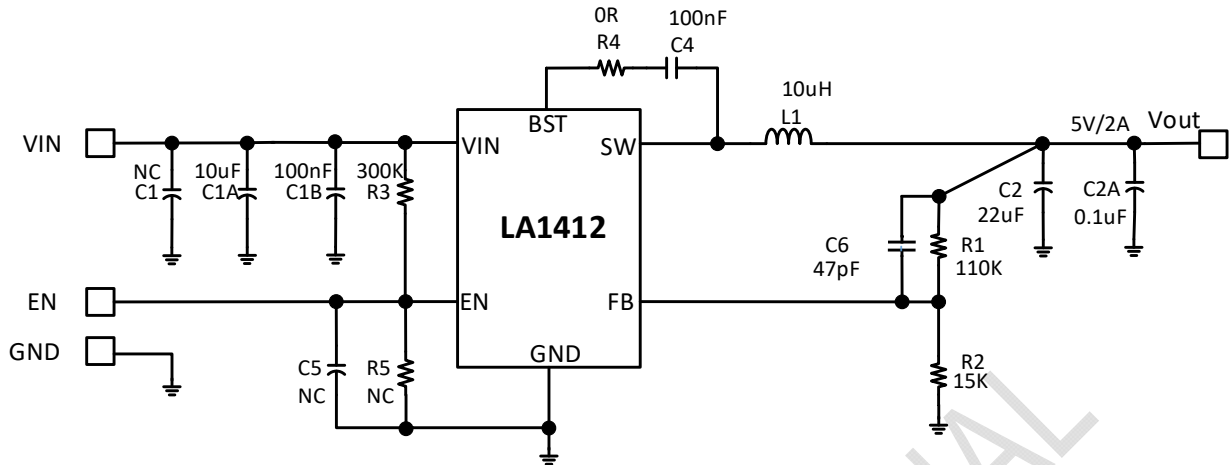

Note: C6 is optional for better transient performance.

VIN=12V VOUT=5V/2A

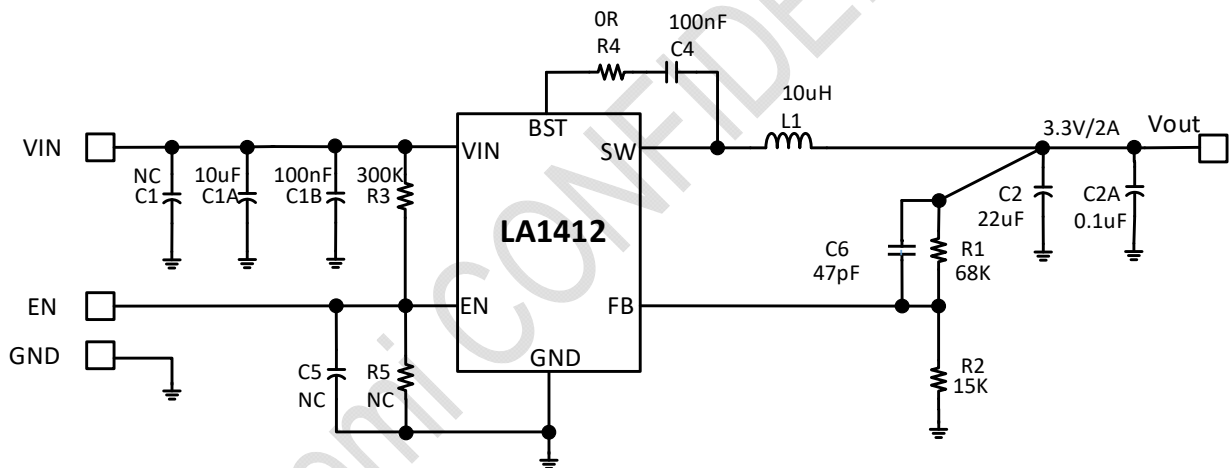

Note: C6 is optional for better transient performance.

VIN=12V VOUT=3.3V/2A

Tape and Reel Information

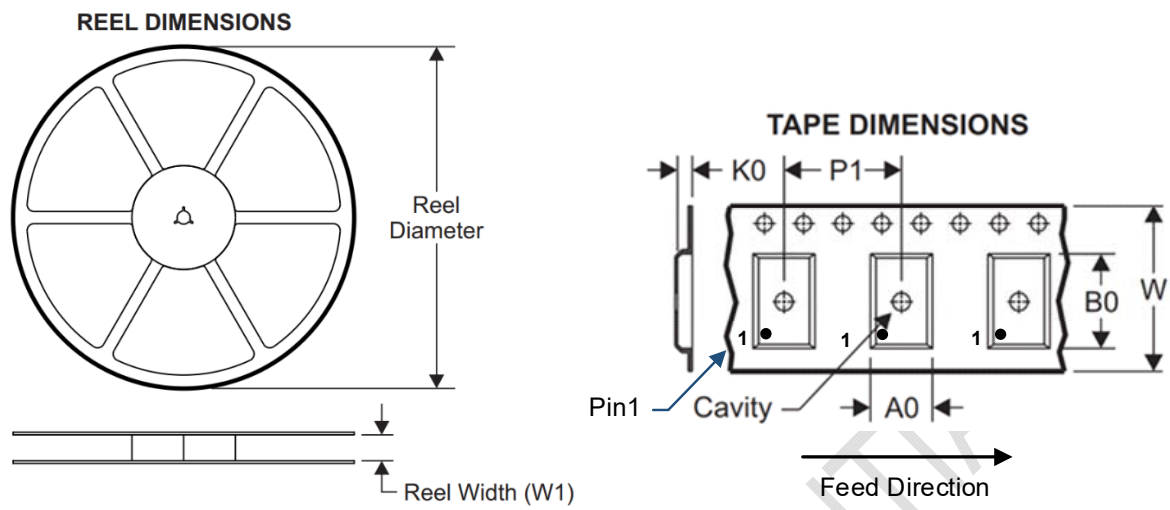

Information

Device	Package Type	Pins	SPQ	Reel Diameter (mm)	Reel Width W1 (mm)	A0 (mm)	B0 (mm)	K0 (mm)	P1 (mm)	W (mm)
LA1412	SOT23-6L	6	3000	178	9	3.25	3.3	1.38	4	8



Detail Package Outline Drawing

Package type: SOT23-6L

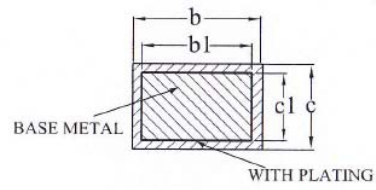
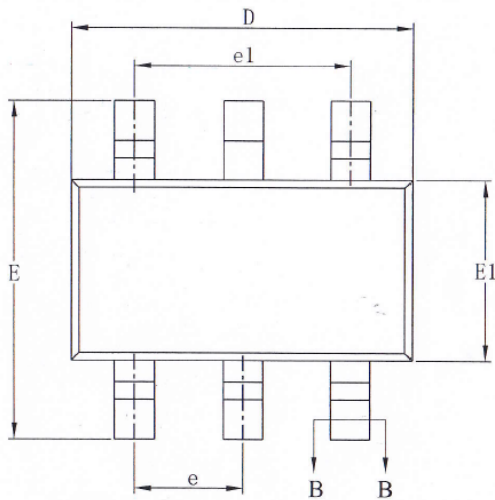
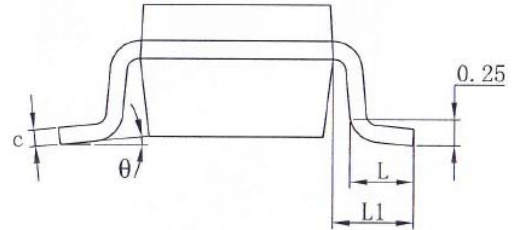
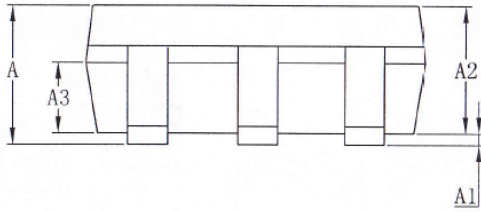

SECTION B-B

SYMBOL	MILLIMETER		
	MIN	NOM	MAX
A	—	—	1.25
A1	0.04	—	0.10
A2	1.00	1.10	1.20
A3	0.60	0.65	0.70
b	0.33	—	0.41
b1	0.32	0.35	0.38
c	0.15	—	0.19
c1	0.14	0.15	0.16
D	2.82	2.92	3.02
E	2.60	2.80	3.00
E1	1.50	1.60	1.70
e	0.95BSC		
e1	1.90BSC		
L	0.30	—	0.60
θ	0	—	8°