

SANYO	No.1513D	LA3600
	5-BAND GRAPHIC EQUALIZER	

Applications

- . Portable component stereos, tape-recorders, radio-cassette recorders, car stereos.

Features

- . On-chip one operational amplifier
- . 5-band graphic equalizer for one channel can be formed easily by externally connecting capacitors and variable resistors which fix f_o (resonance frequency).
- . Series connection of two LA3600's makes multiband (6 to 10 bands) available.
- . Highly stable to capacitive load.

Maximum Ratings at Ta=25°C

Maximum Supply Voltage	V_{CC} max	20	unit	V
Allowable Power Dissipation	P_d max	300		mW
Operating Temperature	T_{opr}	-20 to +75		°C
Storage Temperature	T_{stg}	-40 to +125		°C

Operating Conditions at Ta=25°C

Recommended Supply Voltage	V_{CC}	8	unit	V
Operating Voltage Range	V_{CC} op	5 to 15		V

Operating Characteristics at Ta=25°C, $V_{CC}=8V, R_L=10k\Omega, R_g=600\Omega$,

		See specified Test Circuit.	min	typ	max	unit
Quiescent Current	I_{cco}		3.0	5.0	8.0	mA
Voltage Gain	VG	$f=1kHz, V_{in}=-10dB$ at all flat mode	-3.8	0.8	+2.2	dB
Boost Amount	BOOST	$f=100Hz$	8	10	12	dB
		$f=340Hz$	8	10	12	dB
		$f=1kHz$	8	10	12	dB
		$f=3.4kHz$	8	10	12	dB
		$f=10kHz$	8	10	12	dB
Cut Amount	CUT	$f=100Hz$	-12	-10	-8	dB
		$f=340Hz$	-12	-10	-8	dB
		$f=1kHz$	-12	-10	-8	dB
		$f=3.4kHz$	-12	-10	-8	dB
		$f=10kHz$	-12	-10	-8	dB
Total Harmonic Distortion	THD	$f=1kHz, v_o=1.0V$	0.03	0.1		%
Output Noise Voltage	V_{NO}	$R_g=0, All$ flat B.P.F. 10Hz to 30kHz	2.0	20		μV

Package Dimensions (unit: mm)

3006B

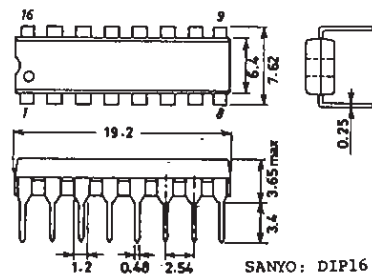

LA3600

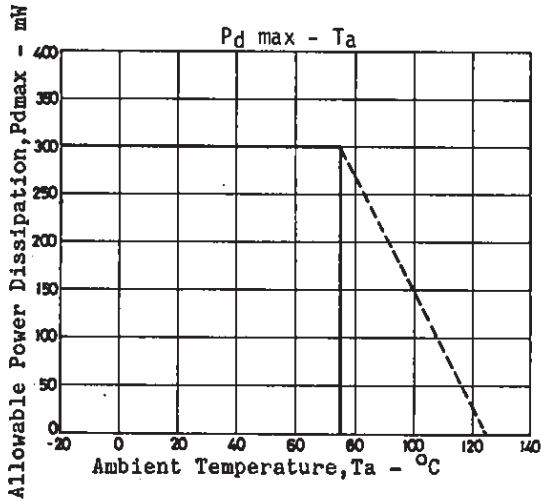

Test Method: $V_{CC}=8V, R_L=10k\Omega, R_g=600\Omega$

Item	SW1	SW2	SW3	SW4	SW5	SW6	SW7	SW8	Conditions
I _{cco}	1	-	-	-	-	-	2	1	
VG	2	F	F	F	F	F	1	1	f=1kHz, V _{in} =-10dB
BOOST	2	B	F	F	F	F	1	1	f=100Hz
BOOST	2	F	B	F	F	F	1	1	f=340Hz
BOOST	2	F	F	B	F	F	1	1	f=1kHz
BOOST	2	F	F	F	B	F	1	1	f=3.4kHz
BOOST	2	F	F	F	F	B	1	1	f=10kHz
CUT	2	C	F	F	F	F	1	1	f=100Hz
CUT	2	F	C	F	F	F	1	1	f=340Hz
CUT	2	F	F	C	F	F	1	1	f=1kHz
CUT	2	F	F	F	C	F	1	1	f=3.4kHz
CUT	2	F	F	F	F	C	1	1	f=10kHz
THD	2	F	F	F	F	F	1	1	f=1kHz, V _o =1.0V
VNO	2	F	F	F	F	F	2	2	

Test Circuit

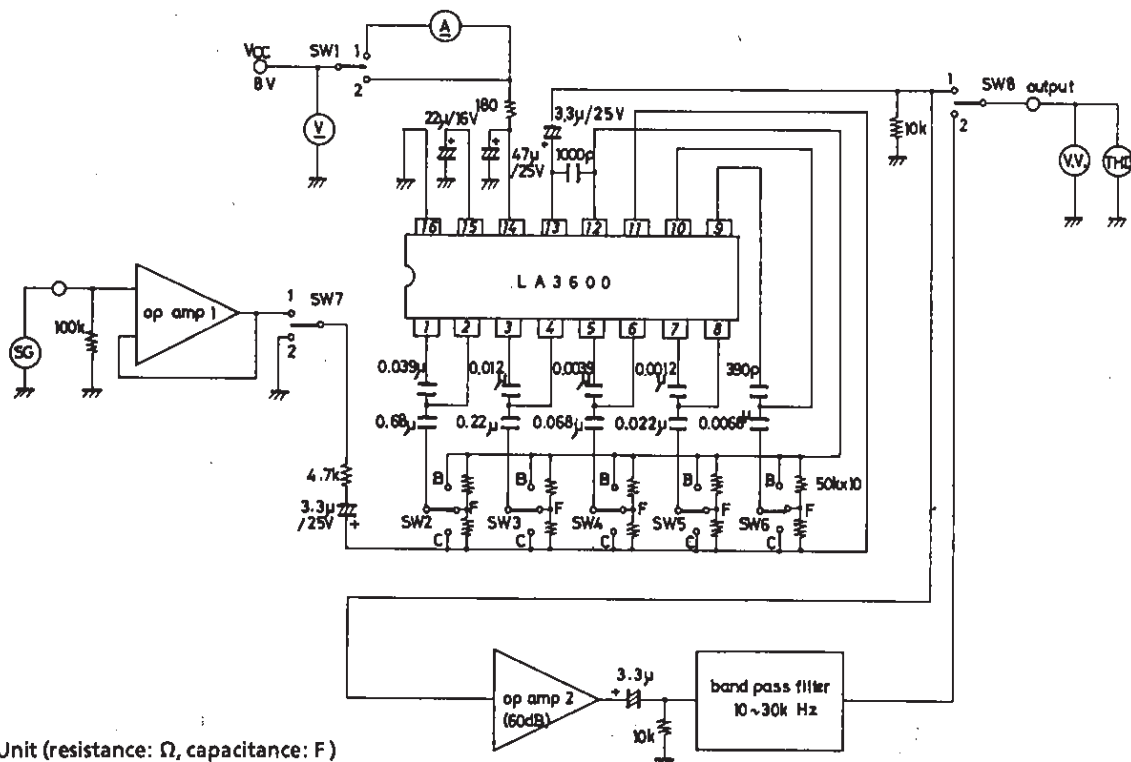

LA3600

Equivalent Circuit Block Diagram

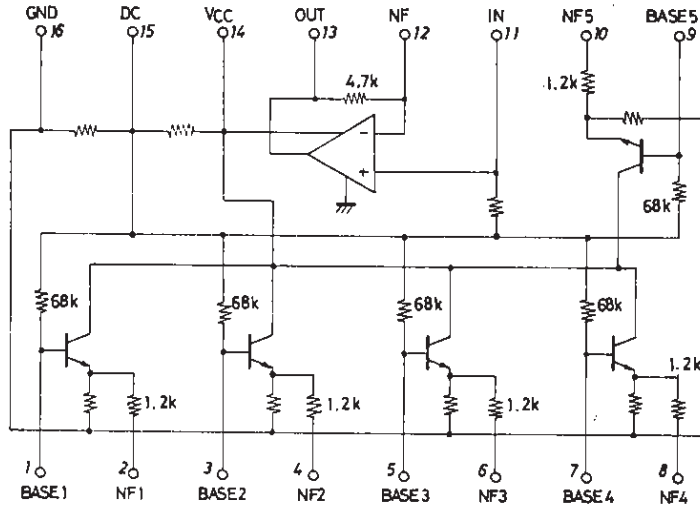

Sample Application Circuit

Unit (resistance: Ω, capacitance: F)

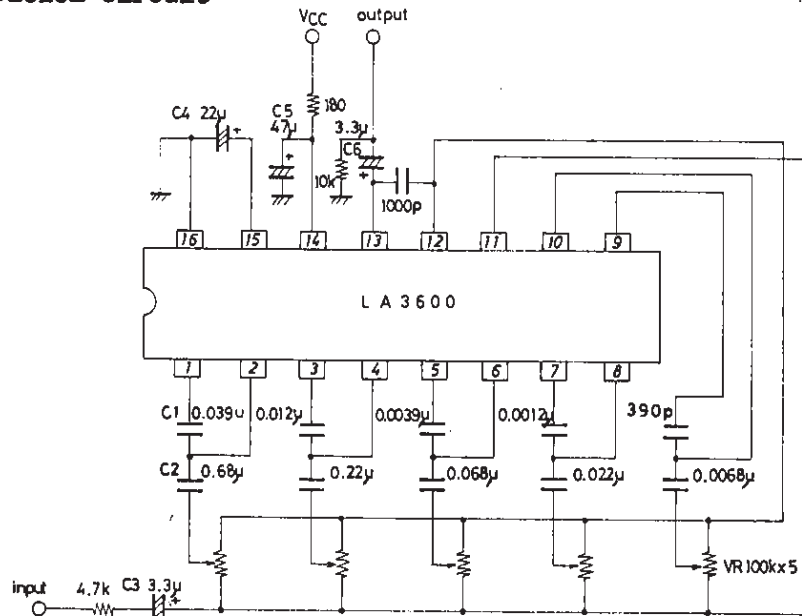

fo(resonance frequency)

In the sample application circuit, fo for each of 5 bands is set as follows:

fo = 108Hz, 343kHz, 1.08kHz, 3.43kHz, 10.8kHz

$$f_o = \frac{1}{2\pi \sqrt{C1, C2, R1, R2}} \quad (R1=1.2\text{kohms}, R2=68\text{kohms on-chip resistor})$$

Description of external parts

C1, C2 : Capacitors used to fix fo (resonance frequency)

C2 : Input capacitor. Decreasing the capacitor value lowers the frequency response at low frequencies.

C3 : Input capacitor. Decreasing the capacitor value lowers the frequency response at low frequencies.

C4 : Decoupling capacitor. Decreasing the capacitor value makes the effect of power supply stronger, whereby ripple is liable to occur.

C5 : Power capacitor.

C6 : Output capacitor. Decreasing the capacitor value lowers the frequency response at low frequencies.

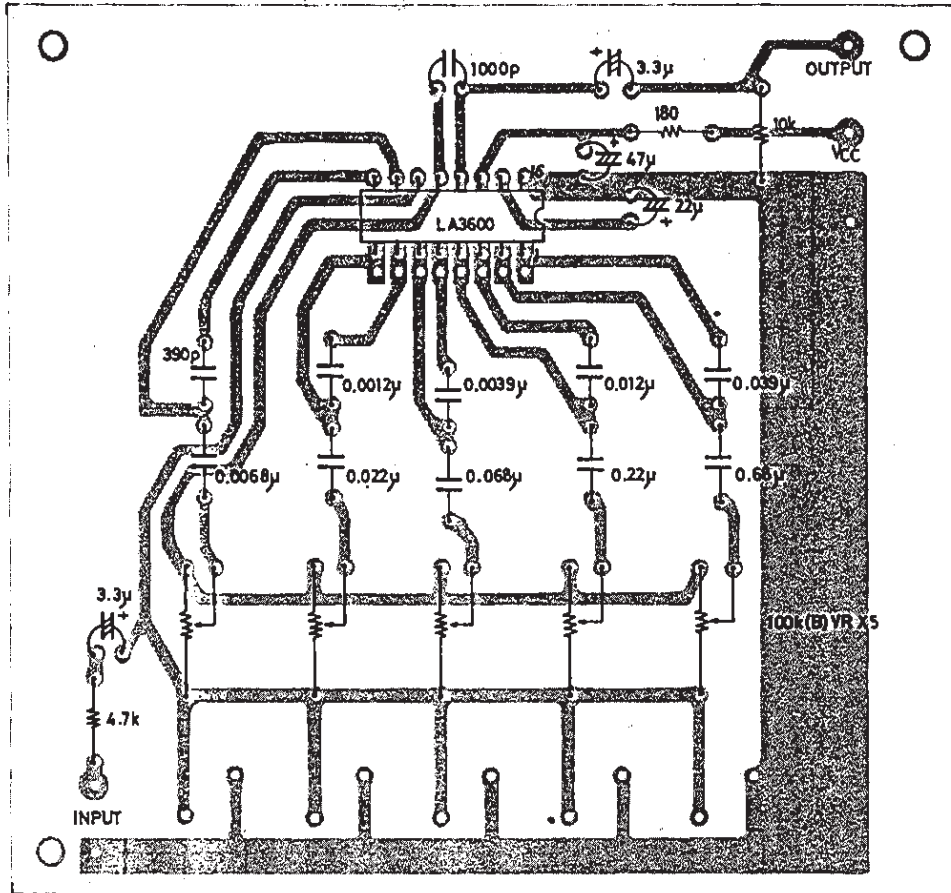

Cu-foiled area 110X102.5mm²

Proper cares in using IC

- Maximum supply voltage V_{CC} max 20V must not be exceeded. The operating voltage is in the range of 5 to 15V.
- Application of power with the pin-to-pin spaces shorted causes breakdown or deterioration of the IC to occur. When mounting the IC on the board or applying power, make sure that the pin-to-pin spaces are not shorted with solder, etc.

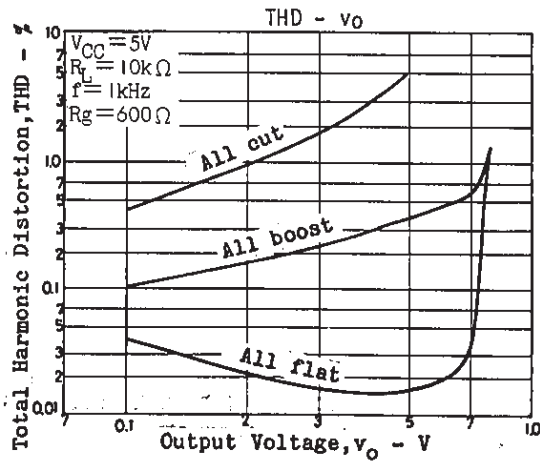
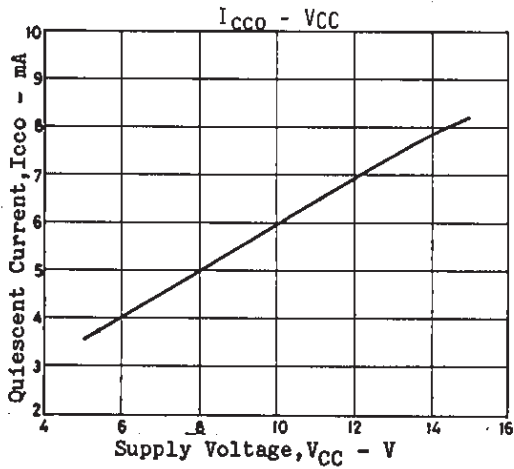

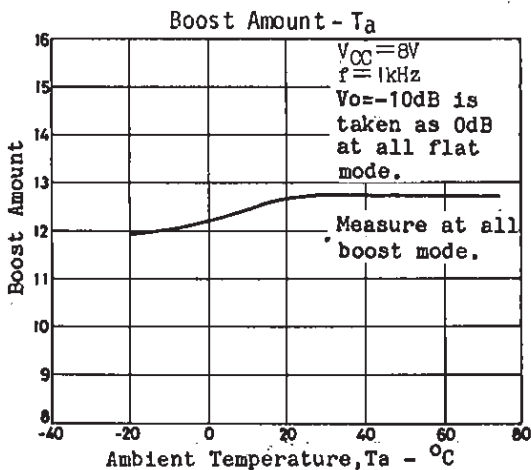
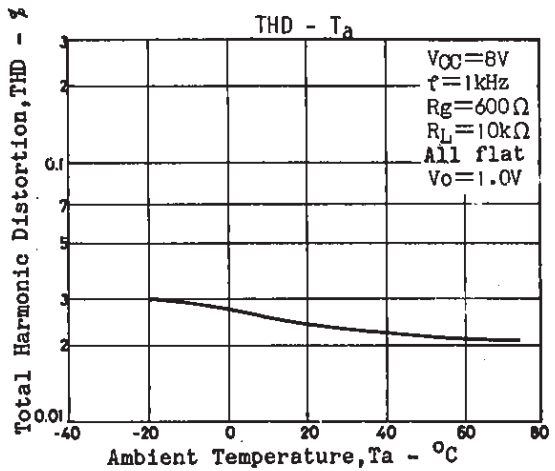
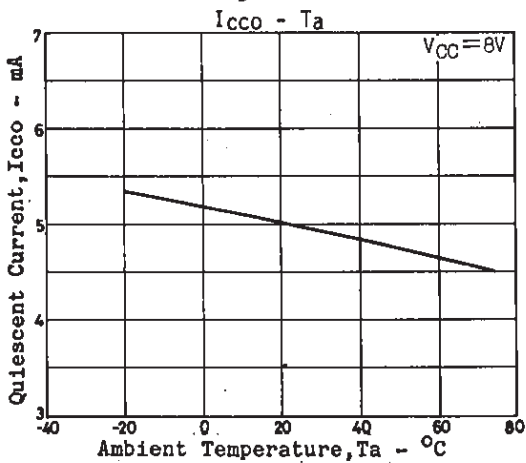
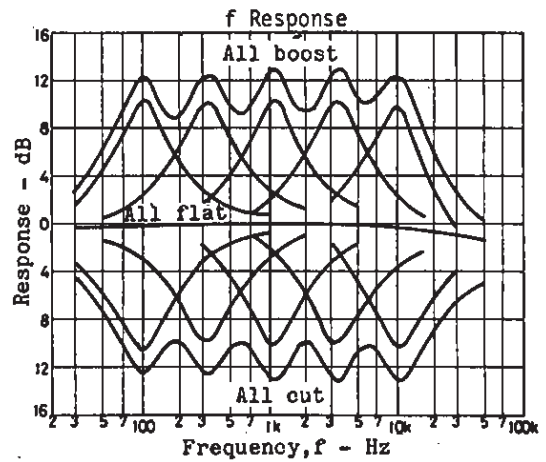
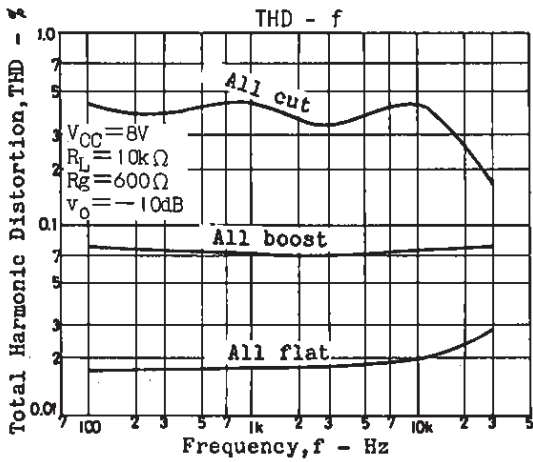
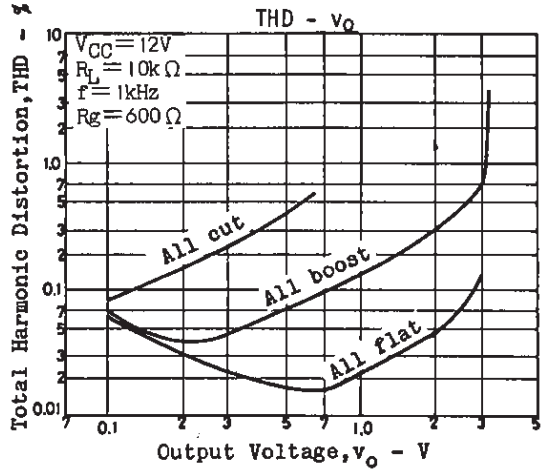
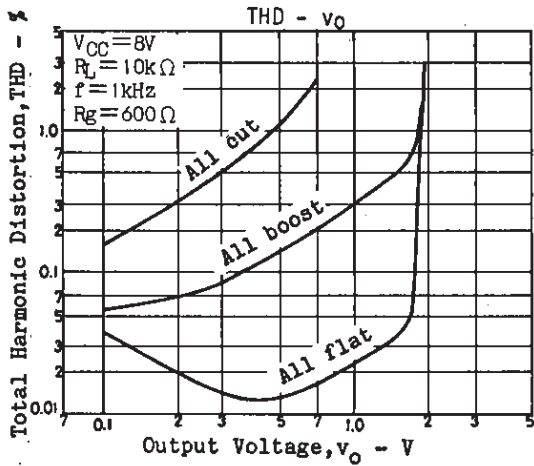

- No products described or contained herein are intended for use in surgical implants, life-support systems, aerospace equipment, nuclear power control systems, vehicles, disaster/crime-prevention equipment and the like, the failure of which may directly or indirectly cause injury, death or property loss.
- Anyone purchasing any products described or contained herein for an above-mentioned use shall:
 - ① Accept full responsibility and indemnify and defend SANYO ELECTRIC CO., LTD., its affiliates, subsidiaries and distributors and all their officers and employees, jointly and severally, against any and all claims and litigation and all damages, cost and expenses associated with such use:
 - ② Not impose any responsibility for any fault or negligence which may be cited in any such claim or litigation on SANYO ELECTRIC CO., LTD., its affiliates, subsidiaries and distributors or any of their officers and employees jointly or severally.
- Information (including circuit diagrams and circuit parameters) herein is for example only; it is not guaranteed for volume production. SANYO believes information herein is accurate and reliable, but no guarantees are made or implied regarding its use or any infringements of intellectual property rights or other rights of third parties.