



LA5550, 5550M

Low-Voltage DC Motor Speed Controller with Logic Circuit

Applications

The LA5550, 5550M are low-voltage (3V min.) DC motor speed control IC with bidirectional driver and logic circuit. Speed control, function control of DC motor for cassette tape recorder, tape deck, telephone answering machine.

Features

- Wide operating voltage range :1.8 to 8V.
- Has a logic circuit which operates in such a manner as 2 logic inputs cause FF, REW, GOVERNOR, BRAKE mode to occur.
- Easy to vary speed at the GOVERNOR mode.
- Turning OFF the strobe pin cause little I_{CC} to flow (100 μ A).
- Large starting torque.

Package Dimensions

unit:mm

3006B-DIP16

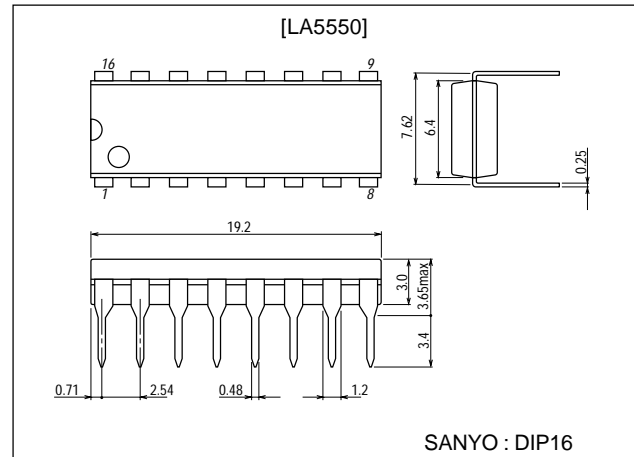

unit:mm

3036B-MFP20

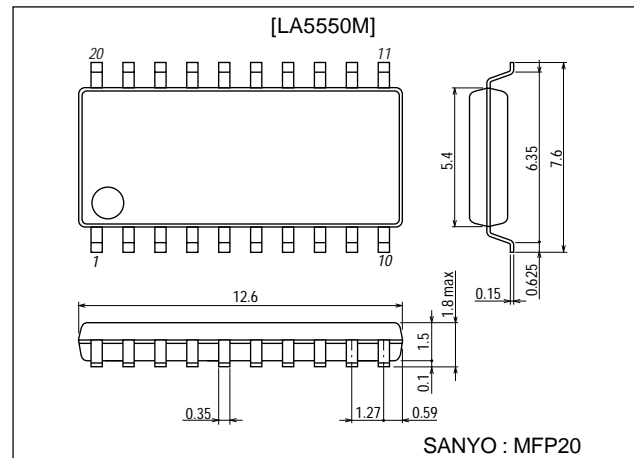

■ Any and all SANYO products described or contained herein do not have specifications that can handle applications that require extremely high levels of reliability, such as life-support systems, aircraft's control systems, or other applications whose failure can be reasonably expected to result in serious physical and/or material damage. Consult with your SANYO representative nearest you before using any SANYO products described or contained herein in such applications.

■ SANYO assumes no responsibility for equipment failures that result from using products at values that exceed, even momentarily, rated values (such as maximum ratings, operating condition ranges, or other parameters) listed in products specifications of any and all SANYO products described or contained herein.

SANYO Electric Co.,Ltd. Semiconductor Company

TOKYO OFFICE Tokyo Bldg., 1-10, 1 Chome, Ueno, Taito-ku, TOKYO, 110-8534 JAPAN

LA5550, 5550M

Specifications

Maximum Ratings at Ta = 25°C

Parameter	Symbol	Conditions	Ratings	Unit
Maximum supply voltage	V _{CC} max		8	V
Allowable power dissipation	Pd max	LA5550	1	W
		LA5550M	0.42	W
Maximum motor current	I _m max		1000	mA
Operating temperature	Topr		-20 to +80	°C
Storage temperature	Tstg		-40 to +150	°C

Operating Conditions at Ta = 25°C

Parameter	Symbol	Conditions	Ratings	Unit
Supply voltage range	V _{CC} op		1.8 to 8	V

Operating Characteristics at Ta = 25°C

Parameter	Symbol	Conditions	Ratings			Unit
			min	typ	max	
[GOVERNOR Mode (G)]						
Reference voltage	V _{ref}	V _{CC} =3V, I _m =100mA	1.1	1.2	1.3	V
Quiescent flow-in current dissipation	I _d	V _{CC} =3V, motor open		8	15	mA
Shunt ratio	K	V _{CC} =3V, I _m =50mA, 150mA	45	50	55	
Residual voltage	V _{sat} (G)	V _{CC} =3V, I _m =200mA		0.27	0.5	V
Voltage characteristic of reference voltage	$\frac{\Delta V_{ref}}{V_{ref}} / \Delta V$	V _{CC} =1.8 to 8V, I _m =100mA		0.26	0.5	%/V
Voltage characteristic of shunt ratio	$\frac{\Delta K}{K} / \Delta V$	V _{CC} =1.8 to 8V, I _m =50mA, 150mA		0.45		%/V
Current characteristic of reference voltage	$\frac{\Delta V_{ref}}{V_{ref}} / \Delta I_m$	V _{CC} =3V, I _m =20 to 200mA,		0.05	0.1	%/mA
Current characteristic of shunt ratio	$\frac{\Delta K}{K} / \Delta I_m$	V _{CC} =3V, I _m =50, 100mA to 150, 200mA		-0.02		%/mA
[FF Mode]						
Quiescent current dissipation	I _d (F)	V _{CC} =3V, motor open		18.5	23	mA
Residual voltage	V _{ast} (F)	V _{CC} =3V, I _m =200mA		0.28	0.5	V
[REW Mode]						
Quiescent current dissipation	I _d (R)	V _{CC} =3V, motor open		18.5	23	mA
Residual voltage	V _{ast} (R)	V _{CC} =3V, I _m =200mA		0.30	0.5	V
[STOP Mode]						
Quiescent current dissipation	I _d (S)	V _{CC} =3V (STB-ON)		26	30	mA
Strobe current	I _{STB}	V _{CC} =3V (STB-OFF)		100	200	μA
Base Pull-in current	I _{B1} , I _{B2}	V _{CC} =3V, Modes other than BRAKE	3.8	4.4	5.8	mA

Equivalent Circuit Block Diagram

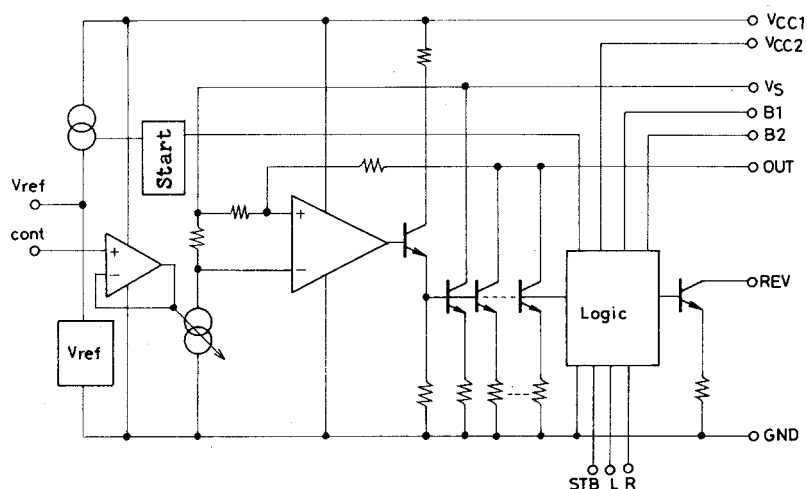

LA5550, 5550M

Pin Assignments

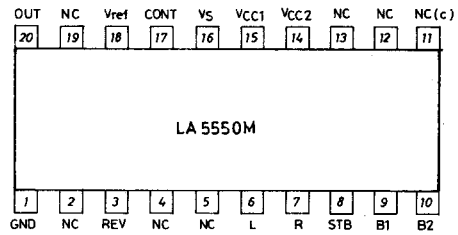
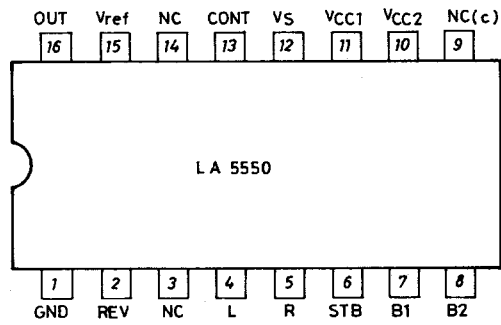

(Top view)

Sample Application Circuit (1)

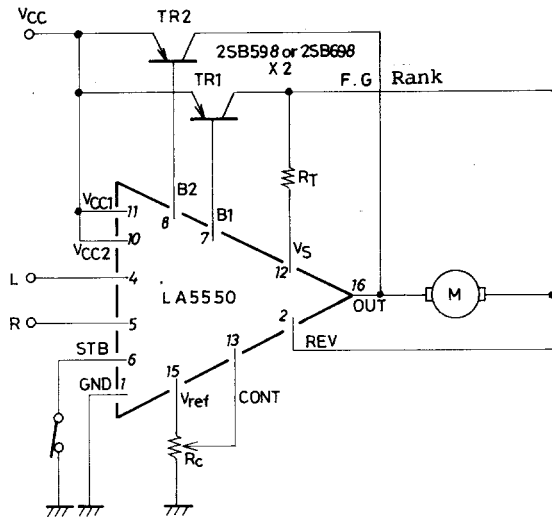

* Assuming $R_T < K \cdot R_m$

Mode	L	R
High-speed FF	0	0
GOVERNOR FF	0	1
High-speed REW	1	0
Brake	1	1

0 : 0 to 0.3V
1 : 1.8V to V_{CC}

Sample Application Circuit (2) : Bidirectional Governor

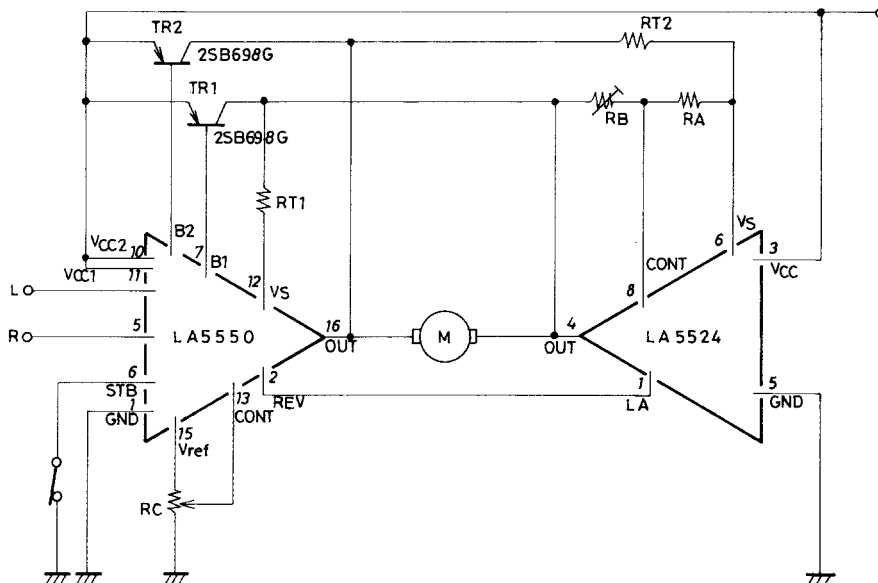

$R_A = 2.2k\Omega$
 $R_C = 50k\Omega$, V_R
 $R_C = 30k\Omega$, V_R

Turning OFF the STB pin causes $I_{CC} < 100\mu A$ (at 3V).

Mode	L	R
High-speed FF	0	0
FF control	0	1
REW control	1	0
Brake	1	1

- Specifications of any and all SANYO products described or contained herein stipulate the performance, characteristics, and functions of the described products in the independent state, and are not guarantees of the performance, characteristics, and functions of the described products as mounted in the customer's products or equipment. To verify symptoms and states that cannot be evaluated in an independent device, the customer should always evaluate and test devices mounted in the customer's products or equipment.
- SANYO Electric Co., Ltd. strives to supply high-quality high-reliability products. However, any and all semiconductor products fail with some probability. It is possible that these probabilistic failures could give rise to accidents or events that could endanger human lives, that could give rise to smoke or fire, or that could cause damage to other property. When designing equipment, adopt safety measures so that these kinds of accidents or events cannot occur. Such measures include but are not limited to protective circuits and error prevention circuits for safe design, redundant design, and structural design.
- In the event that any or all SANYO products(including technical data, services) described or contained herein are controlled under any of applicable local export control laws and regulations, such products must not be exported without obtaining the export license from the authorities concerned in accordance with the above law.
- No part of this publication may be reproduced or transmitted in any form or by any means, electronic or mechanical, including photocopying and recording, or any information storage or retrieval system, or otherwise, without the prior written permission of SANYO Electric Co., Ltd.
- Any and all information described or contained herein are subject to change without notice due to product/technology improvement, etc. When designing equipment, refer to the "Delivery Specification" for the SANYO product that you intend to use.
- Information (including circuit diagrams and circuit parameters) herein is for example only ; it is not guaranteed for volume production. SANYO believes information herein is accurate and reliable, but no guarantees are made or implied regarding its use or any infringements of intellectual property rights or other rights of third parties.

This catalog provides information as of August, 1999. Specifications and information herein are subject to change without notice.