



LA6532M

4-Channel BTL-Use Driver

Overview

The LA6532M is a 4-channel BTL-use driver designed for compact disc pickup actuation.

Functions and Features

- BTL-use 4-channel power amplifier.
- I_O max 700mA×2400mA×2 (with voltage limiter).
- With muting function.

Specifications

Maximum Ratings at $T_a = 25^\circ\text{C}$

Parameter	Symbol	Conditions	Ratings	Unit
Maximum supply voltage	V_{CC} max		9	V
Allowable power dissipation	P_d max		0.9	W
Differential input voltage	V_{ID}		8	V
Common-mode input voltage	V_{ICM}		8	V
Maximum input voltage	V_{INB} max	Buffer amplifier	8	V
Muting pin voltage	V_{Mute}		8	V
Operating temperature	T_{opr}		-20 to +75	$^\circ\text{C}$
Storage temperature	T_{stg}		-55 to +150	$^\circ\text{C}$

Operating Conditions at $T_a = 25^\circ\text{C}$

Parameter	Symbol	Conditions	Ratings	Unit
Maximum supply voltage	V_{CC}		5	V
Load resistance	R_L	Between pins 3 and 4, 12 and 13, 18 and 19, 27 and 28	8	Ω

Operating Characteristics at $T_a = 25^\circ\text{C}$, $V_{CC} = 5.0\text{V}$

Parameter	Symbol	Conditions	Ratings			Unit
			min	typ	max	
No-loaded current drain 1	I_{CC1}	Note 1	25	40	60	mA
No-loaded current drain 2	I_{CC2}	Note 2	5	9	20	mA
No-loaded current drain 3	I_{CC3}	Note 3	25	40	60	mA
No-loaded current drain 4	I_{CC4}	Note 4	5	9	20	mA

Continued on next page.

- Any and all SANYO products described or contained herein do not have specifications that can handle applications that require extremely high levels of reliability, such as life-support systems, aircraft's control systems, or other applications whose failure can be reasonably expected to result in serious physical and/or material damage. Consult with your SANYO representative nearest you before using any SANYO products described or contained herein in such applications.
- SANYO assumes no responsibility for equipment failures that result from using products at values that exceed, even momentarily, rated values (such as maximum ratings, operating condition ranges, or other parameters) listed in products specifications of any and all SANYO products described or contained herein.

Package Dimensions

unit:mm

3073A-MFP30SD

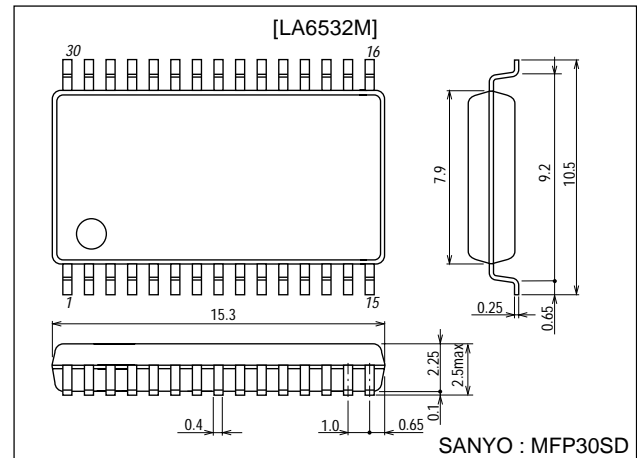

LA6532M

Continued on preceding page.

Parameter	Symbol	Conditions	Ratings			Unit
			min	typ	max	
Output offset voltage 1	V_{OF1}	Note 5, amplifier 1, 2, 7, 8	-50		+50	mV
Output offset voltage 2	V_{OF2}	Note 5, amplifier 3, 4, 5, 6	-30		+30	mV
Buffer 1 input-output voltage difference	V_{BIO1}	Buffer amplifier 1	-30		+30	mV
Buffer 2 input-output voltage difference	V_{BIO2}	Buffer amplifier 2	0.5	0.6	0.8	V
Amplifier 2 input-output voltage difference	V_{IO2}	Amplifier 2	0.5	0.6	0.8	V
Amplifier 7 input-output voltage difference	V_{IO7}	Amplifier 7	0.5	0.6	0.8	V
Input bias current	I_B	Note 6		100	500	nA
Buffer input voltage range	V_{BICM}	Buffer amplifier	1.5		$V_{CC}-1.5$	V
Common-mode input voltage range	V_{ICM}		1.0		$V_{CC}-1.5$	V
Output source voltage	V_{O1}	$R_L=8.0\Omega$ 700mA amplifier, Note 7	3.4	3.6		V
Output sink voltage	V_{O2}	$R_L=8.0\Omega$ 700mA amplifier, Note 8		1.0	1.4	V
Output source voltage	V_{O3}	$R_L=8.0\Omega$ 400mA amplifier, Note 7	2.8	3.4		V
Output sink voltage	V_{O4}	$R_L=8.0\Omega$ 400mA amplifier, Note 8		1.6	2.2	V
Closed-circuit voltage gain	V_G			6.0		dB
Output limiting voltage	V_{OL}	Amplifier 3, amplifier 6		5.0		V
Muting pin off-state voltage	V_{Mute}			2.2		V
Muting pin off-state current	I_{Mute}			80		A

Note 1 : Muting OFF. Buffer $22k\Omega$ across V_{IN-} and V_O . V_{IN+} pin grounded

Note 2 : Muting ON. Buffer $22k\Omega$ across V_{IN-} and V_O . V_{IN+} pin grounded

Note 3 : Muting OFF. Buffer $22k\Omega$ across V_{IN-} and V_O . V_{IN+} pin connected to $1/2V_{CC}$

Note 4 : Muting ON. Buffer $22k\Omega$ across V_{IN-} and V_O . V_{IN+} pin connected to $1/2V_{CC}$

Note 5 : For bridge amplifier, represents the difference between outputs.

Note 6 : All V_{IN} connected to $1/2V_{CC}$. $100k\Omega$ connected to the input. Measure the voltage difference.

V_{IN} and V_O connected through $100k\Omega$. Measure the voltage difference between pins.

Note 7 : Voltage (source) relative to GND when 8Ω load is connected across outputs of bridge amplifier

Note 8 : Voltage (sink) relative to GND when 8Ω load is connected across outputs of bridge amplifier

* : Be careful in handling the LA6532M, because dielectric breakdown is liable to occur.

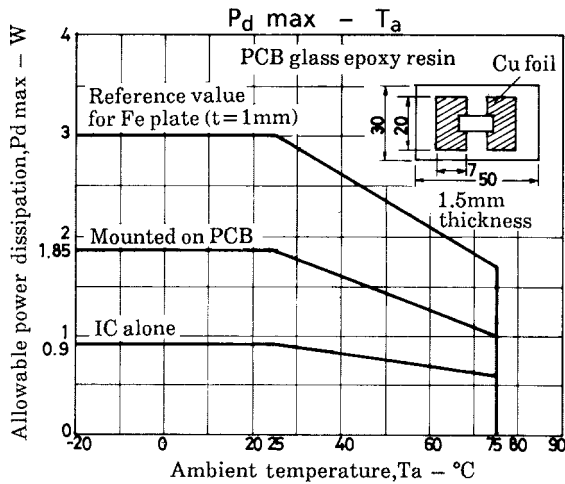

LA6532M

Equivalent Circuit Block Diagram

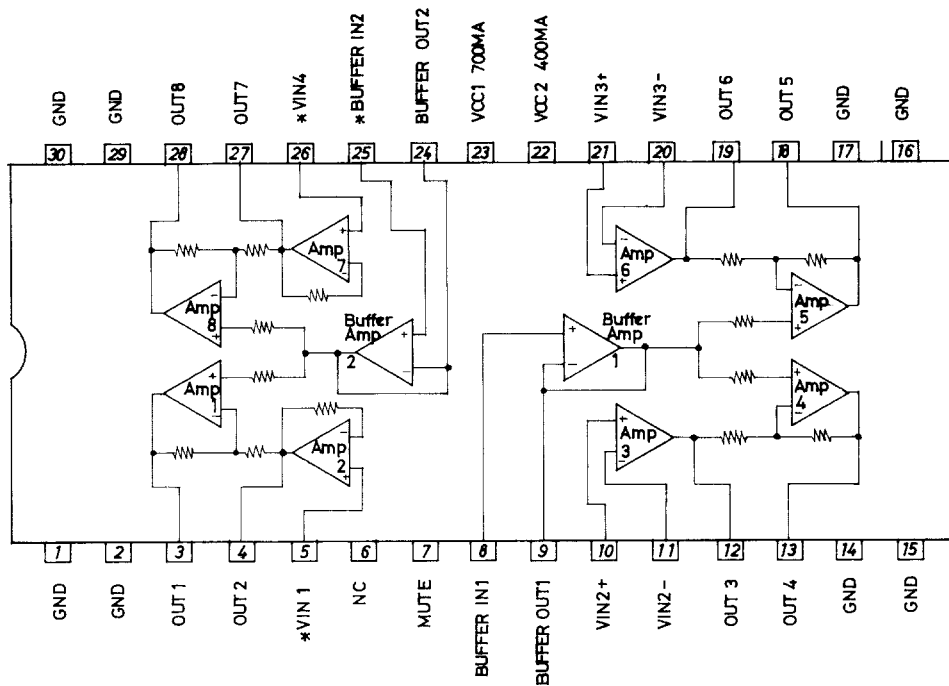

- Specifications of any and all SANYO products described or contained herein stipulate the performance, characteristics, and functions of the described products in the independent state, and are not guarantees of the performance, characteristics, and functions of the described products as mounted in the customer's products or equipment. To verify symptoms and states that cannot be evaluated in an independent device, the customer should always evaluate and test devices mounted in the customer's products or equipment.
- SANYO Electric Co., Ltd. strives to supply high-quality high-reliability products. However, any and all semiconductor products fail with some probability. It is possible that these probabilistic failures could give rise to accidents or events that could endanger human lives, that could give rise to smoke or fire, or that could cause damage to other property. When designing equipment, adopt safety measures so that these kinds of accidents or events cannot occur. Such measures include but are not limited to protective circuits and error prevention circuits for safe design, redundant design, and structural design.
- In the event that any or all SANYO products(including technical data, services) described or contained herein are controlled under any of applicable local export control laws and regulations, such products must not be exported without obtaining the export license from the authorities concerned in accordance with the above law.
- No part of this publication may be reproduced or transmitted in any form or by any means, electronic or mechanical, including photocopying and recording, or any information storage or retrieval system, or otherwise, without the prior written permission of SANYO Electric Co., Ltd.
- Any and all information described or contained herein are subject to change without notice due to product/technology improvement, etc. When designing equipment, refer to the "Delivery Specification" for the SANYO product that you intend to use.
- Information (including circuit diagrams and circuit parameters) herein is for example only ; it is not guaranteed for volume production. SANYO believes information herein is accurate and reliable, but no guarantees are made or implied regarding its use or any infringements of intellectual property rights or other rights of third parties.

This catalog provides information as of April, 2000. Specifications and information herein are subject to change without notice.