



SANYO Semiconductors DATA SHEET

LA6584 — Monolithic Linear IC BTL Driver Single-Phase Full-Wave Fan Motor Driver

Overview

The LA6584 is Single-phase bipolar fan motor is put into silent driving by means of BTL output linear drive, offering high efficiency and power saving by suppressing the reactive current. Lock protection and rotation signal (FG, RD) circuits are built in, ensuring optimum application to small fans for notebook PC, consumer equipment power supply, car audio system, CPU cooler, etc. that require high reliability and low noise.

Functions and Applications

- Single-phase full-wave driver for fan motor

Specifications

Absolute Maximum Ratings at $T_a = 25^\circ\text{C}$

Parameter	Symbol	Conditions	Ratings	Unit
Output voltage	V_{CC} max		15	V
Allowable dissipation	P_d max	Mounted on a specified board*	1.1	W
Output current	I_{OUT} max		1.2	A
Output withstand voltage	V_{OUT} max		15	V
RD/FG output pin output Withstand voltage	$V_{RD/FG}$ max		15	V
RD/FG output current	$I_{RD/FG}$ max		5	mA
HB output voltage	I_B max		10	mA
Operating temperature range	T_{opr}		-30 to +90	$^\circ\text{C}$
Storage temperature range	T_{stg}		-55 to +150	$^\circ\text{C}$

*Mounted on a specified board (114.3×76.1×1.6mm, Glass epoxy)

Recommended Operating Range at $T_a = 25^\circ\text{C}$

Parameter	Symbol	Conditions	Ratings	Unit
Supply voltage	V_{CC}		2.8 to 14.0	V
Common-phase input voltage Range of Hall input	VICM		0 to $V_{CC}-1.5$	V

- Any and all SANYO products described or contained herein do not have specifications that can handle applications that require extremely high levels of reliability, such as life-support systems, aircraft's control systems, or other applications whose failure can be reasonably expected to result in serious physical and/or material damage. Consult with your SANYO representative nearest you before using any SANYO products described or contained herein in such applications.
- SANYO assumes no responsibility for equipment failures that result from using products at values that exceed, even momentarily, rated values (such as maximum ratings, operating condition ranges, or other parameters) listed in products specifications of any and all SANYO products described or contained herein.

LA6584

Electrical Characteristics at $T_a = 25^\circ\text{C}$, $V_{CC} = 12\text{V}$, unless especially specified.

Parameter	Symbol	Conditions	Ratings			Unit
			min	typ	max	
Circuit current	I_{CC1}	During drive (CT = L)	4	6	9	mA
	I_{CC2}	During lock protection (CT = H)	2	4	6	mA
Lock detection capacitor charge current	I_{CT1}		2.0	2.8	3.5	μA
Capacitor discharge current	I_{CT2}		0.15	0.23	0.30	μA
Capacitor charge and discharge current ratio	RCT	$RCD = I_{CT1}/I_{CT2}$	9	12	15	-
CT charge voltage	V_{CT1}		1.6	1.7	1.8	V
CT discharge voltage	V_{CT2}		0.6	0.7	0.8	V
OUT output L saturation voltage	V_{OL}	$I_O = 200\text{mA}$		0.2	0.3	V
OUT output H saturation voltage	V_{OH}	$I_O = 200\text{mA}$		0.9	1.2	V
Hall input sensitivity	VHN	Zero peak value (including offset and hysteresis)		7	15	mV
RD/FG output pin L voltage	$V_{RD/FG}$	$I_{RD/FG} = 5\text{mA}$		0.1	0.2	V
RD/FG output pin leak current	$I_{RD/FGL}$	$V_{RD/FG} = 15\text{V}$		1	30	μA
HB output L voltage	V_{HBL}	$I_{HB} = 5\text{mA}$	1.3	1.5	1.7	V

Package Dimensions

unit : mm

3313

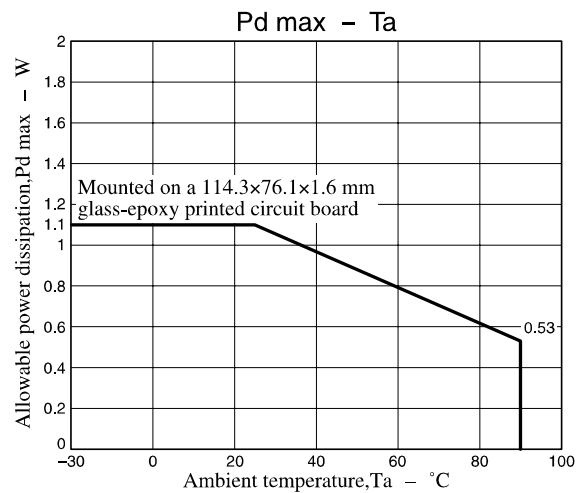
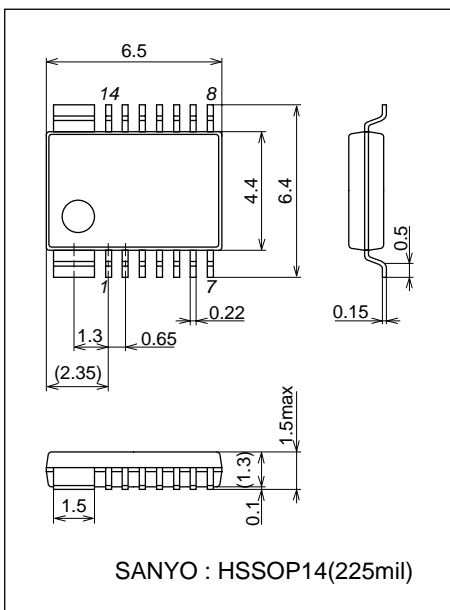

LA6584

Truth Table

IN-	IN+	CT	OUT1	OUT2	FG	RD	Mode
H	L	L	H	L	L	L	During rotation
L	H		L	H	H		
-	-	H	OFF	OFF	-	H	During overheat protection

Pin Assignment

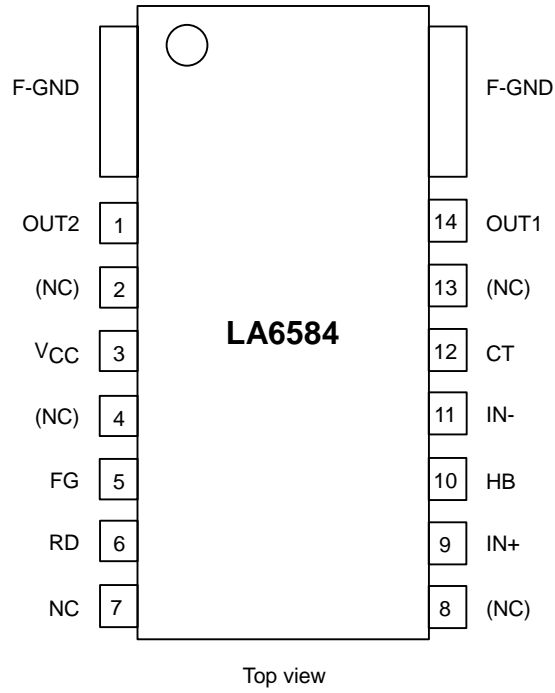

Sample Application Circuit

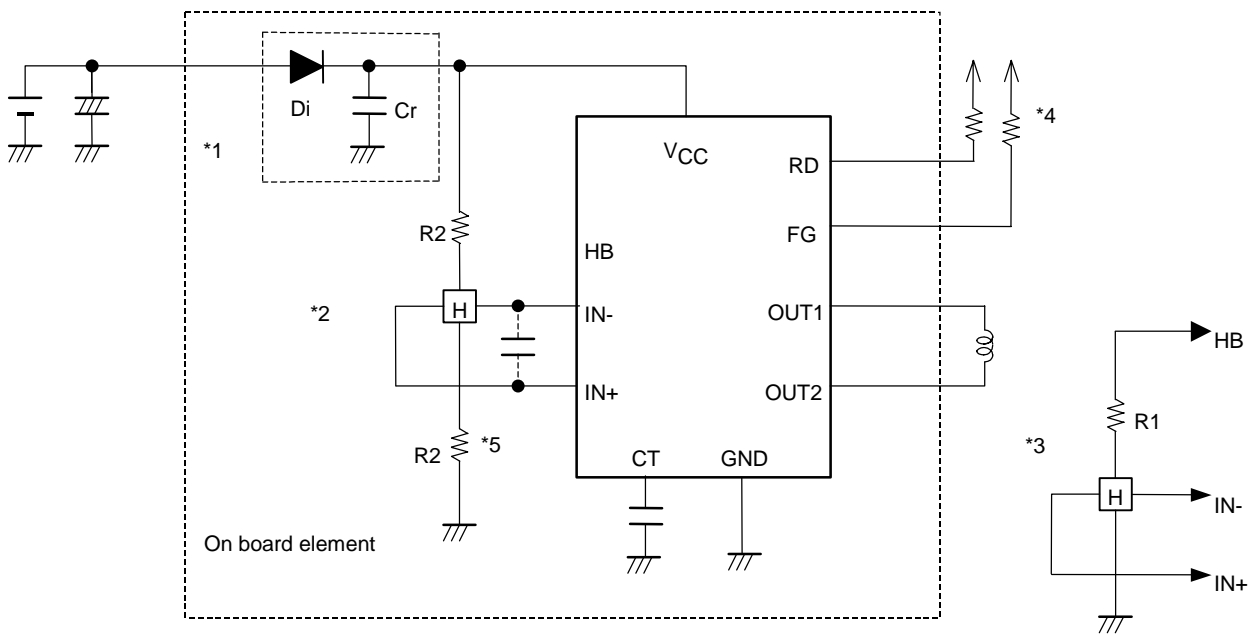

- *1 When Di to prevent breakdown in case of reverse connection is used, it is necessary to insert a capacitor Cr to secure the regenerative current route. Similarly, Cr is necessary to enhance the reliability when there is no capacitor near the fan power line.
- *2 To obtain Hall bias from V_{CC} , carry out $1/2 \times V_{CC}$ bias as shown in the figure. Linear driving is made through voltage control of the coil by amplifying the Hall output. When the Hall element output is large, the startup performance and efficiency are improved. Adjustment of the Hall element can reduce the noise further.
- *3 When the Hall bias is taken from the HB pin, constant-voltage bias is made with about 2.0V. Therefore, the Hall element can provide the output satisfactory in temperature characteristics. Adjustment of the Hall output amplitude is made with R1. (When $V_{CC} = 12V$, the step *2 above proves advantageous for IC heat generation.)
- *4 Keep this open when not used.
- *5 When the wiring from the Hall output to IC Hall input is long, noise may be carried through the wiring. In this case, insert the capacitor as shown in the figure.

Internal Equivalent Circuit

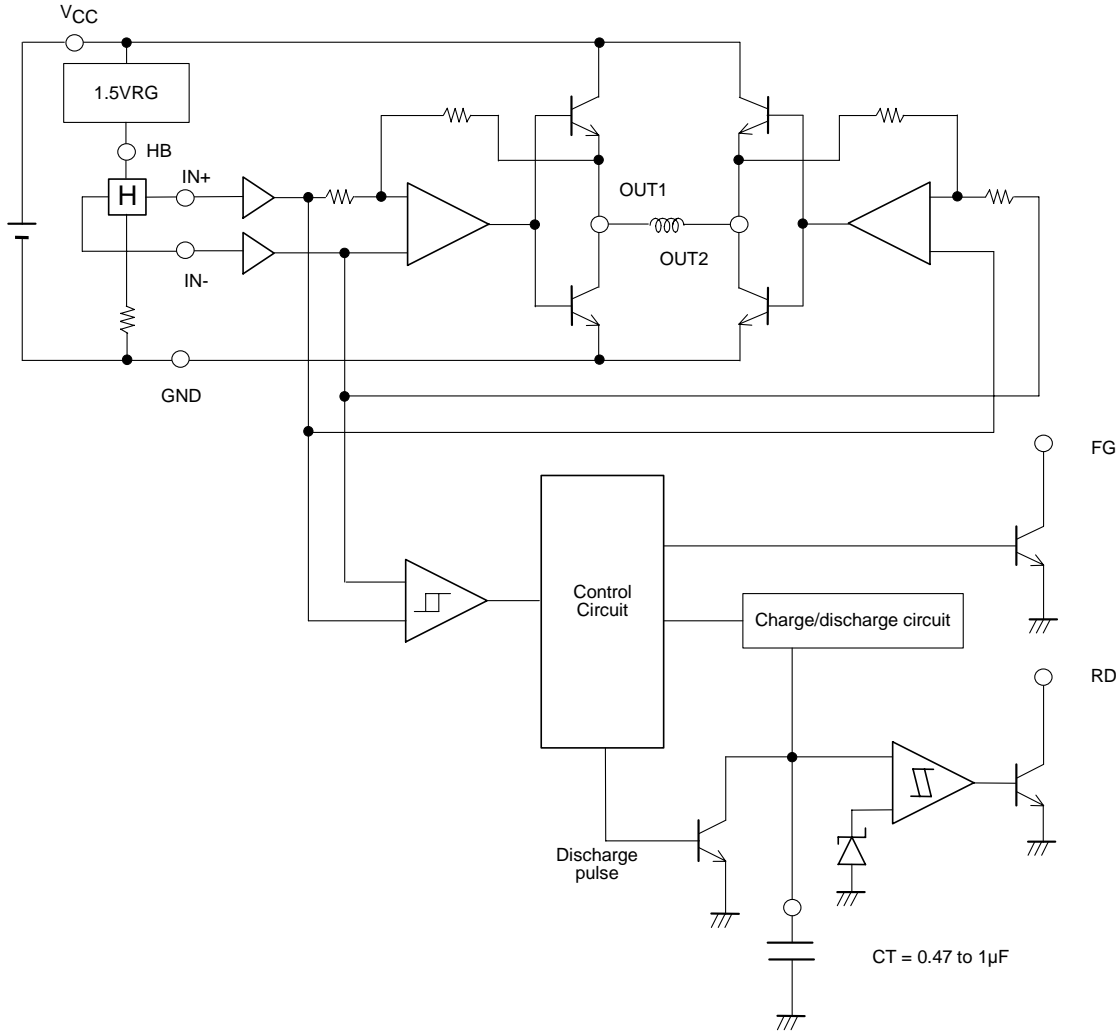

- Specifications of any and all SANYO products described or contained herein stipulate the performance, characteristics, and functions of the described products in the independent state, and are not guarantees of the performance, characteristics, and functions of the described products as mounted in the customer's products or equipment. To verify symptoms and states that cannot be evaluated in an independent device, the customer should always evaluate and test devices mounted in the customer's products or equipment.
- SANYO Electric Co., Ltd. strives to supply high-quality high-reliability products. However, any and all semiconductor products fail with some probability. It is possible that these probabilistic failures could give rise to accidents or events that could endanger human lives, that could give rise to smoke or fire, or that could cause damage to other property. When designing equipment, adopt safety measures so that these kinds of accidents or events cannot occur. Such measures include but are not limited to protective circuits and error prevention circuits for safe design, redundant design, and structural design.
- In the event that any or all SANYO products (including technical data, services) described or contained herein are controlled under any of applicable local export control laws and regulations, such products must not be exported without obtaining the export license from the authorities concerned in accordance with the above law.
- No part of this publication may be reproduced or transmitted in any form or by any means, electronic or mechanical, including photocopying and recording, or any information storage or retrieval system, of otherwise, without the prior written permission of SANYO Electric Co., Ltd.
- Any and all information described or contained herein are subject to change without notice due to product/technology improvement, etc. When designing equipment, refer to the "Delivery Specification" for the SANYO product that you intend to use.
- Information (including circuit diagrams and circuit parameters) herein is for example only; it is not guaranteed for volume production. SANYO believes information herein is accurate and reliable, but no guarantees are made or implied regarding its use or any infringements of intellectual property rights or other rights of third parties.

This catalog provides information as of August, 2005. Specifications and information herein are subject to change without notice.