



SANYO Semiconductors

DATA SHEET

LA6587T — Monolithic Linear IC Fan Motor Driver BTL Driver Single-Phase Full-Wave

Overview

The LA6587T is single-phase bipolar fan motor is driven, through BTL output linear drive, at high efficiency, low power, and low sound by suppressing the reactive power. Lock protection, rotary signal (FG, 1/2FG) circuits are incorporated, which is optimum for the notebook PC, consumer equipment power supply, car audio system, CPU cooler, etc. that require high reliability and low noise.

Functions

- Single-phase full-wave linear drive by BTL output (gain resistance 1k Ω -360k Ω , 51dB)
: No switching noise, which is optimum for equipment requiring silence, such as consumer equipment power supply, car audio system, etc.
- Low-voltage operation possible, with wide operating voltage range (2.2 to 14.0V)
- Low saturation output (Upper + lower saturation voltage : V_{Osat} (total) = 1.1V_{typ}, I_O = 100mA)
: High coil efficiency with low current drain. Additionally, IC itself generates only small heat.
- Built-in lock protection and automatic reset circuits
- Built-in FG & 1/2FG outputs
- Built-in Hall bias (V_{HB} = 1.5V)
- Thermal protection circuit
: When the large current flows due to output short-circuit and the IC chip temperature exceeds 180°C, this protective circuit suppresses the drive current to prevent burn and damage to IC.
- Extra-small package (MSOP10)

Specifications

Absolute Maximum Ratings at Ta = 25°C

Parameter	Symbol	Conditions	Ratings	Unit
Output voltage	V_{CC} max		15	V
Allowable power dissipation	P_d max	Mounted on a specified board*	400	mW
Output current	I_{OUT} max		0.6	A
Output withstand voltage	V_{OUT} max		15	V
RD/FG output pin output withstand voltage	$V_{RD/FG}$ max		15	V
RD/FG output current	$I_{RD/FG}$ max		10	mA

Continued on next page.

- Any and all SANYO Semiconductor products described or contained herein do not have specifications that can handle applications that require extremely high levels of reliability, such as life-support systems, aircraft's control systems, or other applications whose failure can be reasonably expected to result in serious physical and/or material damage. Consult with your SANYO Semiconductor representative nearest you before using any SANYO Semiconductor products described or contained herein in such applications.
- SANYO Semiconductor assumes no responsibility for equipment failures that result from using products at values that exceed, even momentarily, rated values (such as maximum ratings, operating condition ranges, or other parameters) listed in products specifications of any and all SANYO Semiconductor products described or contained herein.

SANYO Semiconductor Co., Ltd.

TOKYO OFFICE Tokyo Bldg., 1-10, 1 Chome, Ueno, Taito-ku, TOKYO, 110-8534 JAPAN

Continued from preceding page.

Parameter	Symbol	Conditions	Ratings	Unit
HB output current	I_B max		10	mA
Operating temperature	T_{opr}		-40 to +85	°C
Storage temperature	T_{stg}		-40 to +150	°C

* Mounted on a specified board : 114.3×76.2×1.5mm³, glass epoxy board.**Operating Conditions** at $T_a = 25^\circ\text{C}$

Parameter	Symbol	Conditions	Ratings	Unit
Supply voltage	V_{CC}		2.2 to 14.0	V
Common-phase input voltage range of Hall input	V_{ICM}		0 to $V_{CC}-1.5$	V

Electrical Characteristics at $T_a = 25^\circ\text{C}$, $V_{CC} = 12\text{V}$, unless especially specified.

Parameter	Symbol	Conditions	Ratings			Unit
			min	typ	max	
Circuit Current	I_{CC1}	During drive (CT = L)	4	6	8	mA
	I_{CC2}	During lock protection (CT = H)	3	4.5	6	mA
Lock detection capacitor charge current	I_{CT1}		0.9	1.2	1.5	μA
Capacitor discharge current	I_{CT2}		0.11	0.18	0.25	μA
Capacitor charge and discharge current ratio	R_{CT}	$RCD = I_{CT1}/I_{CT2}$	5	6.5	8	-
CT charge voltage	V_{CT1}		1.3	1.5	1.6	V
CT discharge voltage	V_{CT2}		0.3	0.5	0.6	V
OUT output L saturation voltage	V_{OL}	$I_O = 200\text{mA}$		0.25	0.45	V
OUT output H saturation voltage	V_{OH}	$I_O = 200\text{mA}$		1.0	1.2	V
Hall input sensitivity	V_{HN}	Zero peak value (including offset and hysteresis)		7	15	mV
FG/1/2FG output pin L voltage	V_{FG}	$I_{FG} = 5\text{mA}$		0.15	0.3	V
FG/1/2FG output pin leak current	I_{FGL}	$V_{FG} = 15\text{V}$		1	30	μA

Truth Table

IN-	IN+	CT	OUT1	OUT2	FG	RD	Mode
H	L	L	H	L	L	*	During rotation
L	H		L	H	H		
-	-	H	off	off	-	-	During overheat protection

* 1/2FG provides the output equivalent to the divided FG output.

Package Dimensions

unit : mm (typ)

3236A

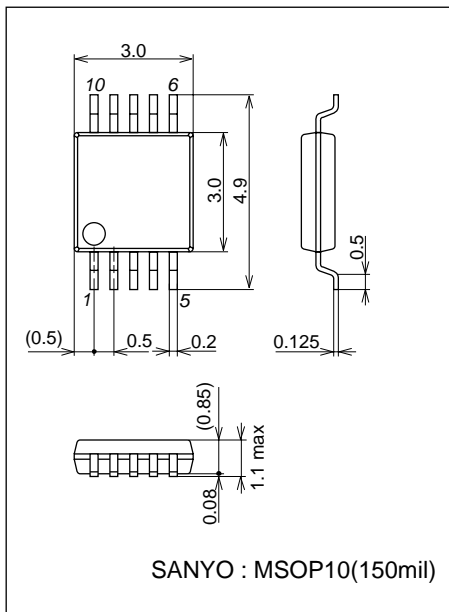
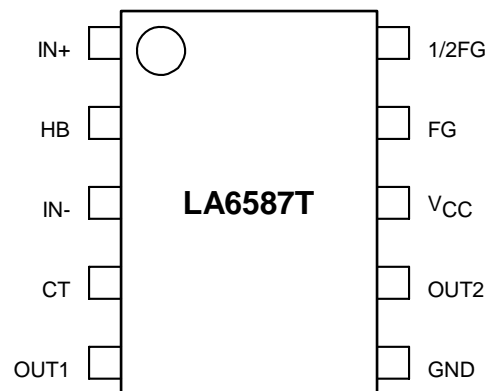
**Pin Assignment**

Top view

Block Diagram

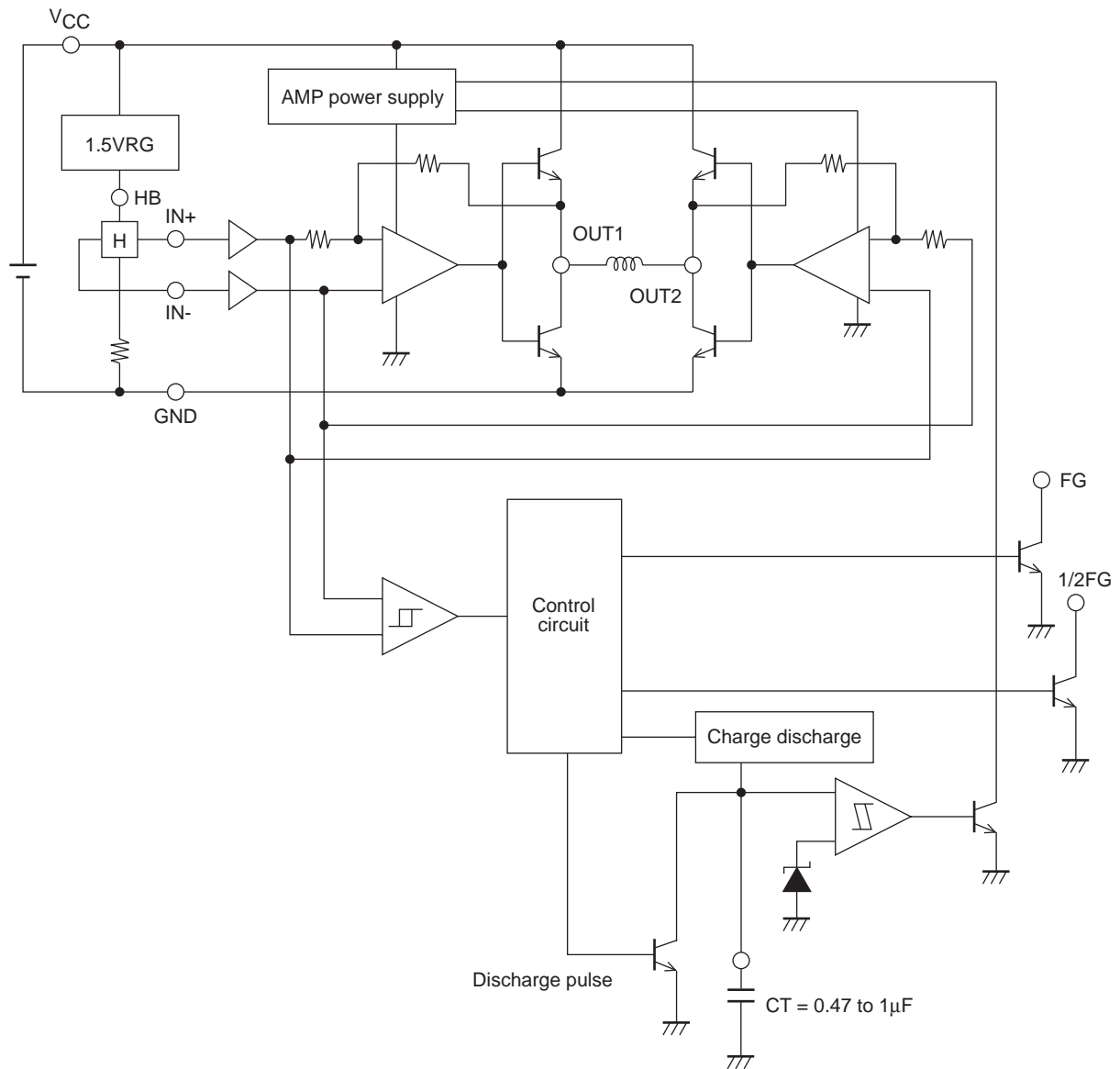

Sample Application Circuit

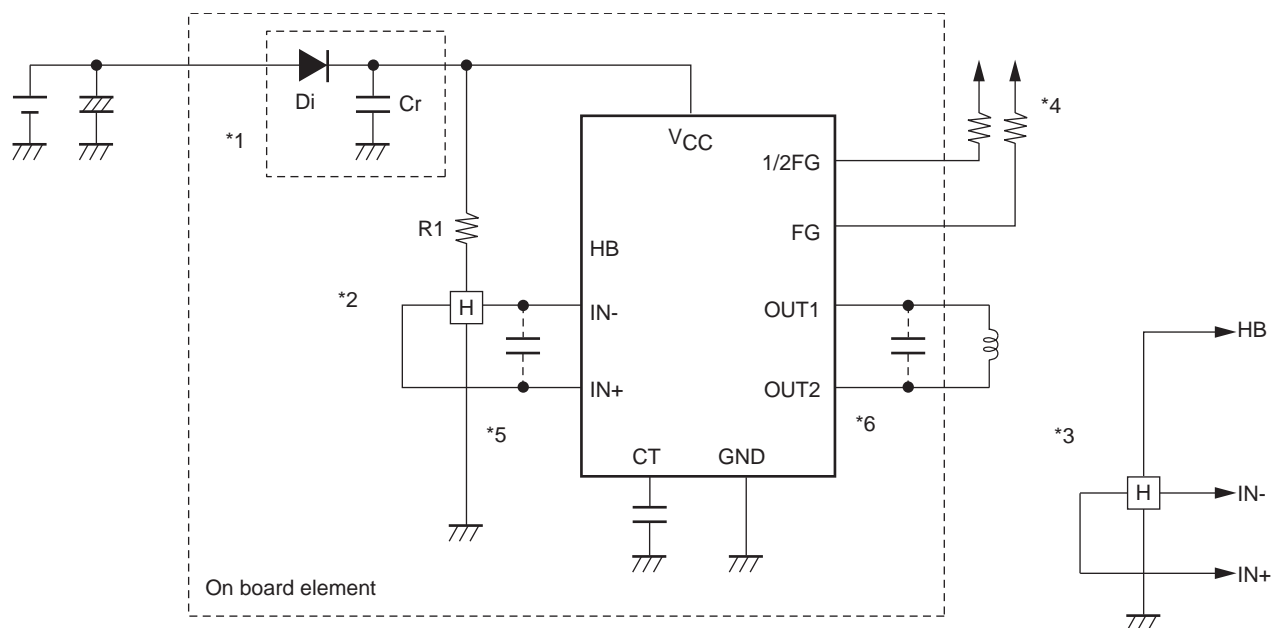

- *1 : When the breakdown protective DI at reverse connection is to be used, it is necessary to insert the capacitor Cr to secure the regenerative current route. Similarly, Cr must be provided to enhance the reliability when there is no capacitor near the fan power line.
- *2 : To obtain Hall bias from V_{CC} , carry out $1V_{CC}$ bias as shown in the figure. Linear driving is made through voltage control of the coil by amplifying the Hall output. When the Hall element output is large, the startup performance and efficiency are improved. Adjustment of the Hall element can reduce the noise further.
- *3 : To obtain Hall bias from the HB pin, carry out constant-voltage bias at about 1.5V, which enables the Hall element to generate the stable Hall output satisfactory in temperature characteristics.
- *4 : Keep this open when not using.
- *5 : When the wiring from the Hall output to IC Hall input is long, noise may be carried through the wiring. In this case, insert the capacitor as shown in the figure.

- Specifications of any and all SANYO Semiconductor products described or contained herein stipulate the performance, characteristics, and functions of the described products in the independent state, and are not guarantees of the performance, characteristics, and functions of the described products as mounted in the customer's products or equipment. To verify symptoms and states that cannot be evaluated in an independent device, the customer should always evaluate and test devices mounted in the customer's products or equipment.
- SANYO Semiconductor Co., Ltd. strives to supply high-quality high-reliability products. However, any and all semiconductor products fail with some probability. It is possible that these probabilistic failures could give rise to accidents or events that could endanger human lives, that could give rise to smoke or fire, or that could cause damage to other property. When designing equipment, adopt safety measures so that these kinds of accidents or events cannot occur. Such measures include but are not limited to protective circuits and error prevention circuits for safe design, redundant design, and structural design.
- In the event that any or all SANYO Semiconductor products (including technical data, services) described or contained herein are controlled under any of applicable local export control laws and regulations, such products must not be exported without obtaining the export license from the authorities concerned in accordance with the above law.
- No part of this publication may be reproduced or transmitted in any form or by any means, electronic or mechanical, including photocopying and recording, or any information storage or retrieval system, or otherwise, without the prior written permission of SANYO Semiconductor Co., Ltd.
- Any and all information described or contained herein are subject to change without notice due to product/technology improvement, etc. When designing equipment, refer to the "Delivery Specification" for the SANYO Semiconductor product that you intend to use.
- Information (including circuit diagrams and circuit parameters) herein is for example only; it is not guaranteed for volume production. SANYO Semiconductor believes information herein is accurate and reliable, but no guarantees are made or implied regarding its use or any infringements of intellectual property rights or other rights of third parties.

This catalog provides information as of December, 2006. Specifications and information herein are subject to change without notice.