



SANYO Semiconductors

DATA SHEET

LA71598HM — **Monolithic Linear IC**
Video Audio Signal Processor
For VHS VCR
(Y/C/A/HA SINGLE-CHIP)

Overview

This LA71598HM is Video Audio Signal Processor for VHS VCR (Y/C/A/HA SINGLE-CHIP).

Specifications

Maximum Ratings at Ta = 25°C

Parameter	Symbol	Conditions	Ratings	Unit
Maximum supply voltage	V _{CC}	Pins 40, 16, 58, 87, 55, 75	7.0	V
Allowable power dissipation	Pd max	Ta≤65°C *	1400	mW
Operating temperature	Topg		-10 to +65	°C
Storage temperature	Tstg		-40 to +150	°C

* Mounted on a board 70×70×1.6mm³, phenol resin laminates.

Recommended Operating Conditions at Ta = 25°C

Parameter	Symbol	Conditions	Ratings	Unit
Recommended supply voltage	V _{CC}	Pins 40, 16, 58, 87, 55, 75	5.0	V
Allowable operating voltage range	V _{CC} opg	Pins40, 16, 58, 87, 55, 75	4.8 to 5.3	V

■ Any and all SANYO Semiconductor products described or contained herein do not have specifications that can handle applications that require extremely high levels of reliability, such as life-support systems, aircraft's control systems, or other applications whose failure can be reasonably expected to result in serious physical and/or material damage. Consult with your SANYO Semiconductor representative nearest you before using any SANYO Semiconductor products described or contained herein in such applications.

■ SANYO Semiconductor assumes no responsibility for equipment failures that result from using products at values that exceed, even momentarily, rated values (such as maximum ratings, operating condition ranges, or other parameters) listed in products specifications of any and all SANYO Semiconductor products described or contained herein.

LA71598HM

Electrical Characteristics at Ta = 25°C, VCC = 5.0V

REC Mode Y

Parameter	Symbol	In	Out	Conditions	Ratings			Unit
					min	typ	max	
Current dissipation (REC)	I _{CCR}			Measure the sum of currents flowing into pins 40, 16, 58, 87, 75.	175	190	205	mA
EE Output level 1 (SW 1)	V _{EE1}	T38A	T29	With V _{IN} a 1Vp-p video signal (PAL), measure the output level on T29.	2.00	2.10	2.20	Vp-p
EE Output level 2 (SW 2)	V _{EE2}	T36A	T29	With V _{IN} a 1Vp-p video signal (NTSC), measure the output level on T29.	2.00	2.10	2.20	Vp-p
EE Output level 3 (SW 3)	V _{EE2}	T34A	T29	With V _{IN} a 1Vp-p video signal (NTSC), measure the output level on T29.	2.00	2.10	2.20	Vp-p
AGC characteristics 1	AGC1	T38A	T29	With V _{IN} a 2.0Vp-p video signal, measure the ratio of the output level on T29 and VEE1.	0	0.6	1.2	dB
AGC characteristics 2	AGC2	T38A	T29	With V _{IN} a 0.5Vp-p video signal, measure the ratio of the output level on T29 and VEE1.	-1.2	-0.2	0.0	dB
AGC characteristics 3	AGC3	T38A	T29	With V _{IN} a 700mVp-p luminance, 600mVp-p sync, measure the sync level on T29.	550	650	750	mVp-p
AGC characteristics 4	AGC4	T38A	T29	With V _{IN} a 700mVp-p luminance, 150mVp-p sync, measure the sync level on T29.	330	380	430	mVp-p
Sync separator output level	VS _{YR}	T38A	T28	With V _{IN} a 1.0Vp-p video signal, measure the output pulse wave height on T28.	4.0	4.2	4.4	Vp-p
Sync separator output pulse width	PWS _{YR}	T38A	T28	With V _{IN} a 1.0Vp-p video signal, measure the output pulse width on T28.	4.4	4.7	5.0	μs
Sync separator threshold level	THS _{YR}	T38A	T28	Gradually reduce the input level, and measure the input level at the point that the output pulse width is 1μs sec or more wider than PWS _{YR} .		-20	-15	dB
H-Sync output level	VHS _{YR}	T38A	T27	With V _{IN} a 1.0Vp-p video signal, measure the output pulse wave height on T27.	4.0	4.2	4.4	Vp-p
H-Sync output pulse width	PWHS _{YR}	T38A	T27	With V _{IN} a 1.0Vp-p video signal, measure the output pulse width on T27.		5.0		μs
Sync tip level Pedestal level White level	LVOR	T38A	T29	With V _{IN} a 1.0Vp-p video signal, measure the sync tip and pedestal and white level on T29 video output, and take these as LSYN LPED LWHT, respectively.				
Quasi-V insertion level	ΔVDR	T38A	T29	Measure the T26 DC voltage with 4.7V applied to T26, and take this to be LVDR, and compute the difference with LSYN measured above. ΔWHR = LSYN-LVDR		0		mV
Quasi-H insertion level	ΔHDR	T38A	T29	Measure the T29 DC voltage with 3.6V applied to T26, and take this to be LHDR, and compute the difference with LPED measured above. ΔHDR = LPED-LHDR		-100		mV
White insertion level	ΔWHR	T38A	T29	Measure the T29 DC voltage with 2.6V applied to T26. and take this to be LWHR, and compute the difference with LWHT measured above. ΔWHR = LWHT-LWHR	Serial 0 1	0		mV
Edge insertion level	ΔEGR	T38A	T29	Measure the T29 DC voltage with 1.5V applied to T26. and take this to be LEGR, and compute the difference with LPED measured above. ΔEGR = LPED-LEGR		-1450		mV
REC YNR operation	RYNR	T38A	T21	V _{IN} =White 50%+CW (31.6mVp-p) Measure the ratio of 32fH component and 32.5fH.	Serial 00: OFF 01: MIN 10: TYP 11: MAX	*	2 4 6	dB
Y LPF frequency characteristics (1)	YL _{PF1}	T38A	T21	With V _{IN} a standard multi-burst signal (1Vp-p), measure the 1MHz response to a 500kHz signal on T21.	-0.6	-0.1	0.4	dB
Y LPF frequency characteristics (2)	YL _{PF2}	T38A	T21	With V _{IN} a standard multi-burst signal (1Vp-p), measure the 2MHz response to a 500kHz signal on T21.	-1.3	-0.3	0.7	dB
Y LPF frequency characteristics (3)	YL _{PF3}	T38A	T21	With V _{IN} a standard multi-burst signal (1Vp-p), measure the 3MHz response to a 500kHz signal on T21.	-4	-2	-0.5	dB

Continued on next page.

LA71598HM

Continued from preceding page.

Parameter	Symbol	In	Out	Conditions	Ratings			Unit
					min	typ	max	
Y LPF frequency characteristics (4)	YLPF4	T38A	T21	With V_{IN} a standard multi-burst signal (1Vp-p) measure the 4.43MHz response to a 500kHz signal on T21.			-25	dB
Y LPF frequency characteristics (5)	YLPF5	T38A	T21	With V_{IN} a standard multi-burst signal (1Vp-p), measure the 3.58MHz response to a 500kHz signal on T21.			-25	dB
FM modulator output level	VFM		T12	Measure the T12 output level with no input.	Serial 00 01 10 11	270 300 330 360		mVp-p
Carrier frequency (Expect M mode)	FFM1		T12	Measure the output frequency on T12 with no input.	3.725	3.80	3.875	MHz
Carrier frequency (PAL/MESECAM/SEC AM)	FFM2		T12	Measure the output frequency on T12 with no input.	3.30	3.40	3.50	MHz
REC-FM output second distortion	HMOD		T12	Measure the second distortion with the above state.		-40	-35	dB
Deviation (PAL/MESECAM/SEC AM)	DEV1	T38A	T12	With V_{IN} a 100% white 1Vp-p signal, measure the deviation on T5.	0.95	1.00	1.05	MHz
White peak Frequency	FWP	T38A	T12	With V_{IN} a 100% white 1Vp-p signal, measure the White peak frequency on T12.	4.7	4.8	4.9	MHz
FM modulator linearity	LMOD	T20	T12	Let $f_{2.85}$ be the output frequency when 2.85VDC is applied to T20. $LMOD = \frac{f_{2.85} - (f_{3.1} + f_{2.6})/2}{f_{3.1} - f_{2.6}} \times 100$	-2	0	2	%
1/2 fH carrier shift	CS		T12	The output frequency change	6.5	8.2	9.5	kHz
Emphasis gain	GEMP	T20A	T18	With V_{IN} a 500mVp-p 10kHz sine wave, measure the ratio of the levels on T20A and T18.	-0.75	-0.25	0.25	dB
Detail enhancer Characteristics (1)	GENH1	T20A	T18	With V_{IN} a 158mVp-p 2MHz sine wave, measure the ratio of the levels on T20A and T18, and take the difference with GEMP.	Serial 000: MIN ↑↓ 100: TYP ↑↓ 111: MAX	1.0 1.5	2.0	dB
Detail enhancer Characteristics (2)	GENH2	T20A	T18	With V_{IN} a 50mVp-p 2MHz sine wave, measure the ratio of the levels on T20A and T18, and take the difference with GEMP.	Serial 000: MIN ↑↓ 100: TYP ↑↓ 111: MAX	3.0 4.0	5.0	dB
Detail enhancer Characteristics (3)	GENH3	T20A	T18	With V_{IN} a 15.8mVp-p 2MHz sine wave, measure the ratio of the levels on T20A and T18, and take the difference with GEMP.	Serial 000: MIN ↑↓ 100: TYP ↑↓ 111: MAX	4.3 5.8	7.3	dB
Nonlinear emphasis Characteristics (1)	GNLEMP1	T20A	T18	With V_{IN} a 500mVp-p 2MHz sine wave, measure the ratio of the levels on T20A and T18, and take the difference with GEMP. (Y-TEST)	Serial 01: MAX 10: TYP 11: MIN		0.5	dB
Nonlinear emphasis Characteristics (2)	GNLEMP2	T20A	T18	With V_{IN} a 158mVp-p 2MHz sine wave, measure the ratio of the levels on T20A and T18, and take the difference with GEMP. (Y-TEST)	Serial 01: MAX 10: TYP 11: MIN		4	dB
Nonlinear emphasis Characteristics (3)	GNLEMP3	T20A	T18	With V_{IN} a 50mVp-p 2MHz sine wave, measure the ratio of the levels on T20A and T18, and take the difference with GEMP. (Y-TEST)	Serial 01: MAX 10: TYP 11: MIN		6	dB

Continued on next page.

LA71598HM

Continued from preceding page.

Parameter	Symbol	In	Out	Conditions	Ratings			Unit
					min	typ	max	
Main linear emphasis Characteristics (1)	GME1	T20A	T18	With V_{IN} a 50mVp-p 500kHz sine wave, measure the ratio of the levels on T20A and T18, and take the difference with GEMP. (Y-TEST)		11.0		dB
Main linear emphasis Characteristics (2)	GME2	T20A	T18	With V_{IN} a 50mVp-p 2MHz sine wave, measure the ratio of the levels on T20A and T18, and take the difference with GEMP. (Y-TEST)	13.1	13.6	14.1	dB
White clipping level	LWC	T38A	T18	With V_{IN} a 1.0Vp-p 100% white video signal, measure the white clipping level on T18. (Y-TEST)	Serial 0 1	185 195		%
Dark clipping level	LDC	T38A	T18	With V_{IN} a 1.0Vp-p 100% white video signal, measure the dark clipping level on T18. (Y-TEST)	Serial 0 1	-52 -57.5		%

PB Mode Y

Parameter	Symbol	In	Out	Conditions	Ratings			Unit
					min	typ	max	
Current dissipation (PB)	I_{CCP}			Measure the sum of currents flowing into pins 40, 16, 58, 87, 75.	185	200	215	mA
Dropout compensation Period *1H for one horizontal synchronization period	TDOC	T74 T20A	T29	T74: 4MHz 300mVp-p sine wave T20A: 0.5Vp-p video signal The time between the instant the T74A input set to and the point T29 output is restored.	10.5	12.5	14.5	H
DOC characteristics	GDOC	T74 T20A	T29	T74: 4MHz 300mVp-p sine wave T20A: 0.5Vp-p video signal The I/O response 5H after the T74A input is set to 0.	-1.5	0	1.5	dB
PB Y level	V-YOUT	T74	T29	DEV = 1.0MHz PB Y level when input FM signal.	2.00	2.10	2.20	Vp-p
Over all Y level	R/P-OUT	T74	T29	R/P-Y level, PB-Y level	1.93	2.10	2.27	Vp-p
FM demodulator linearity	LDEM	T74	T21	$LDEM = \frac{VDEM4 - (VDEM3 + VDEM5)/2}{VDEM5 - VDEM3} \times 100$ *VDEM4 = DC: T21 (Input 4MHz, 300mVp-p)	-3.5	0	+3.5	%
Carrier leakage	CL	T74	T21	Measure the ratio of the 4MHz component on T21 and SDEM.			-35	dB
PB YNR characteristics	PYNR	T20A	T29	Measure the ratio of the 32fH component and 32.5fH.	Serial 00 (OFF) 01 (STD) 10 (MID) 11 (STG)	0 -3.2 -8.2 -11.8		dB
DOC level	LDOC	T74	T29	Measure the level of D.O.C when 300mVp-p is set to 0Db with $V_{IN} = 4MHz$.		-16		dB
DOC stop level	LDOS	T74	T29	Measure the level when D.O.C stops when the $V_{IN} = 4MHz$ signal is entered.		100		mVp-p
Nonlinear de-emphasis characteristics (1)	GNLDE1	T20A	T29	With V_{IN} a 50% white video +2MHz 158mVp-p sine wave, measure the I/O response. (Y-TEST)	Serial 01: MAX 10: TYP 11: MIN	-3.5 -2.5	-1.5	dB
Nonlinear de-emphasis characteristics (2)	GNLDE2	T20A	T29	f = 2MHz, 50mVp-p (Y-TEST)	Serial 01: MAX 10: TYP 11: MIN	-6.0 -4.5	-3.0	dB
Double noisecanceller characteristics (1)	GWNC1	T20A	T29	f = 1.4MHz, 158mVp-p	Serial 000: MIN 100: TYP 111: MAX	-3.5 -2.5	-1.5	dB
Double noisecanceller characteristics (2)	GWNC2	T20A	T29	f = 1.4MHz, 50mVp-p	Serial 000: MIN 100: TYP 111: MAX	-12 -10	-8	dB

Continued on next page.

LA71598HM

Continued from preceding page.

Parameter	Symbol	In	Out	Conditions	Ratings			Unit
					min	typ	max	
Double noisecanceller characteristics (3)	GWNC3	T20A	T29	f = 1.4MHz, 15.8mVp-p Serial 000: MIN 100: TYP 111: MAX	-15	-13	-11	dB
PIC-CTL Hard MAX	GPH1	T20A	T29	f = 2.5MHz, 158mVp-p	6.0	7.0	8.0	dB
PIC-CTL Soft MAX	GPSF	T20A	T29	f = 2.5MHz, 158mVp-p	-8.8	-6.8	-4.8	dB
Sync separator output level	VSYP	T20A	T28	With V_{IN} a 0.5Vp-p video signal, measure the output pulse wave height on T28.	4.0	4.2	4.4	Vp-p
Sync separator output pulse width	PWSYP	T20A	T28	With V_{IN} a 0.5Vp-p video signal, measure the output pulse width on T28.	4.35	4.65	4.95	μ s
H-Sync output level	VHSYP	T20A	T27	With V_{IN} 0.5Vp-p video signal, measure the output pulse wave height on T27.	4.0	4.2	4.4	Vp-p
H-Sync output pulse width	PWHSYP	T20A	T27	With V_{IN} a 0.5Vp-p video signal, measure the output pulse width on T27.		5.0		μ s
Sync tip level Pedestal level white level	LVOR	T20A	T229	With V_{IN} a 100% white 0.5Vp-p signal, measure the sync tip and pedestal and white levels on T29 video output, and take these as LSYN LPED LWHT, respectively.				
Quasi-V insertion level	Δ VDP	T20A	T29	Measure the T29 DC voltage with 4.7V applied to T26, and take this to be LVDP, and compute the difference with LSYN measured above. Δ VDP = LSYN-LVDP		0		mV
Quasi-H insertion level	Δ HDP	T20A	T29	Measure the T29 DC voltage with 3.6V applied to T26, and take this to be LHDP, and compute the difference with LPED measured above. Δ HDP = LPED-LHDP		-100		mV
White insertion level	Δ WHP	T20A	T29	Measure the T29 DC voltage with 2.6V applied to T26, and take this to be LWHP, and compute the difference with LWHT measured Δ WHP = LWHT-LWHP		-1450		mV
Edge insertion level	Δ EGP	T20A	T29	Measure the T29 DC voltage with 1.5V applied to T26, and take this to be LEGP, and compute the difference with LPED measured Δ WHP = LPED-LEGP		-100		mV
4V regulator	VREG		T39	Measure the T39 DC level.	3.9	4.0	4.1	V

REC Mode EQ

Parameter	Symbol	In	Out	Conditions	Ratings			Unit
					min	typ	max	
REC EQ characteristics 1	GREQ1	T17A	T12	With V_{IN} a CW 2MHz, 300mVp-p signal, measure the input/output response.	-5.5	-4.5	-3.5	dB
REC EQ characteristics 2	GREQ2	T17A	T12	With V_{IN} a CW 4MHz, 300mVp-p signal, measure the input/output response, and take the difference with GREQ1.	-3.7	-2.7	-1.7	dB
REC EQ 2'nd distortion	HREQ	T17A	T12	Measure the second harmonic in the above conditions.		-40	-35	dB
REC EQ characteristics 3	GREQ3	T17A	T12	With V_{IN} a CW 750kHz, 400mVp-p signal, measure the input/output response.			-20	dB

PB Mode EQ

Parameter	Symbol	In	Out	Conditions	Ratings			Unit
					min	typ	max	
PB EQ characteristics 1 *Serial-control	GPEQ1	T74	T18	With V_{IN} a CW 4MHz 300mVp-p signal, measure the input/output response.	1.5	3.0	4.5	dB
PB EQ 2'nd distortion	HPEQ	T74	T18	Measure the second harmonic in the above condition.		-40	-30	dB
PB EQ Low-Trap characteristics 1 *Serial control	FPEQ1	T74	T18	V_{IN} =300mVp-p Measure the Low-band Trap frequency and gain. (Using network analyzer)	Serial 00 (650k) 01 (800k) 10 (1.1M) 11 (500k)		-25 -25 -25 -25	dB
PB EQ High-Trap characteristics 2 *Serial control	FPEQ2	T74	T18	V_{IN} =300mVp-p Measure the High-band Trap frequency and gain. (Using network analyzer)	Serial 00 (10M) 01 (9M) 10 (8M) 11 (7M)		-25 -25 -25 -25	dB

REC Mode Chroma

Parameter	Symbol	In	Out	Conditions	Ratings			Unit
					min	typ	max	
REC chroma low frequency conversion output level	VOR-72	T38A	T72	With V_{IN} the standard color bar signal (1Vp-p), measure the burst level on T72.	Serial 00 01 10 11	225 190 160 135		mVp-p
VXO oscillation level PAL MODE	VVXO-RP	T38A	T69A	With V_{IN} the standard color bar signal (1Vp-p), measure the T69A output amplitude with an FET probe.	300	500	700	mVp-p
REC ACC Characteristics (1)	ACCR1	T38A	T72	With V_{IN} the standard color bar signal (1Vp-p), increase only the chroma signal level by +6dB, measure the T72 burst level, and calculate its ratio with VOR-2.		+0.2	+0.5	dB
REC ACC characteristics (2)	ACCR2	T38A	T72	With V_{IN} the standard color bar signal (1Vp-p), decrease only the chroma signal level by -6dB, measure the T72 burst level, and calculate its ratio with VOR-2.	-0.5	-0.1		dB
REC ACC killer-on input level	VACCK-ON	T38A	T72	With V_{IN} the standard color bar signal (1Vp-p), decrease the chroma signal and measure the input burst level at the point that T72 output ceases. Calculate the ratio of this value with the standard input level.		-26		dB
REC ACC killer-on output level	VOACCK	T38A	T72	Measure the T72 output level with a spectrum analyzer in the killer state of the above item and calculate its ratio with VOR-2.		-60	-50	dB
REC ACC killer restored input level	VACCK-OFF	T38A	T72	From the killer state of the above item gradually increase the input chroma level and T72 output reappears. Calculate its ratio with the standard input level.		-20		dB
REC APC pull-in range (1) PAL MODE	Δf_{APC1}	T38A	T72	Input a signal consisting of a 4.43361875MHz, 300mVp-p CW added to a 50% white signal. After confirming that a signal is output from T72, increase the CW frequency until T72 output ceases. Now slowly reduce the CW frequency, and let f1 be the frequency at which T72 output reappears. $\Delta f_{APC1} = f1 - 4433618.75$ (Hz)	300			Hz
REC APC pull-in range (2) PAL MODE	Δf_{APC2}	T38A	T72	As in the previous item, decrease the CW frequency until T72 output ceases. Now, slowly increase the CW frequency and let f2 be the frequency at which T72 output reappears. $\Delta f_{APC2} = f2 - 4433618.75$ (Hz)			-300	Hz

Continued on next page.

LA71598HM

Continued from preceding page.

Parameter	Symbol	In	Out	Conditions	Ratings			Unit
					min	typ	max	
REC AFC pull-in range (1)	Δf_{AFC1}	T38A	T62	Input a 300mVp-p, 15.6kHz, 5 μ s width pulse train (negative polarity). After increasing the pulse train frequency until the T62 wave form is disrupted, decrease the frequency until the T62 wave form returns to normal and let f1 be that frequency. $\Delta f_{AFC1} = f1 - 15.625$ (kHz)	1.0			kHz
REC AFC pull-in range (2)	Δf_{AFC2}	T38A	T62	With the initial conditions of the previous item, decrease the pulse train frequency until the output is disrupted, then increase the frequency until the output returns to normal, and let f2 be that frequency. $\Delta f_{AFC2} = f2 - 15.625$ (kHz)		-2.5	-1.0	kHz
The ratio of the REC chroma level and FM modulator output level 1 PAL MODE	C/FM1	T38A	T72 T12	The ratio of 100% chroma's level which was converted to low band and FM modulator output level. *Serial Gr6: ---- --00, Gr7: ---- --00		-8		dB
PILOT BURST Amplitude	LPB	T38A	T72	The amplitude of pilot burst which was inserted in recording.		100		mVp-p
PILOT BURST Phase	PPB	T38A	T72	The phase of pilot burst which was inserted in recording.		270		deg
NEM AFC pull-in range(1)	Δf_{NAFC1}	T38A	T35	Input a 300mVp-p, 15.6kHz, 5 μ s width pulse train (negative polarity). After increasing the pulse train frequency until the T35 wave form is disrupted, decrease the frequency until the T35 wave form returns to normal and let f1 be that frequency. $\Delta f_{AFC1} = f1 - 15.625$ (kHz)	1.0			kHz
NEW AFC pull-in range (2)	Δf_{NAFC2}	T38A	T35	With the initial conditions of the previous item, Decrease the pulse train frequency until the output is disrupted, then increase the frequency until the output returns to normal, and let f2 be that frequency. $\Delta f_{AFC2} = f2 - 15.625$ (kHz)		-2.5	-1.0	kHz
Output level of 2fsc	L2FSC		T56	To measure the amplitude of pin56 with no signal at pin38 in recording	200	300		mVp-p
Harmonics of 2fsc	HFSC2		T56	At first to measure the fsc component of pin56. At last, to compare the ratio between fsc and 2fsc component with no signal at pin38 in recording	-10	-15		dB
Harmonics of 2fsc	HFSC3		T56	At first to measure the 3fsc component of pin56. At last, to compare the ratio between 3fsc and 2fsc component with no signal at pin38 in recording	-10	-15		dB

PB Mode Chroma

Parameter	Symbol	In	Out	Conditions	Ratings			Unit
					min	typ	max	
PB chroma video output level PAL MODE	PVop-29	T74A T20A	T29	Input a chroma signal that is a lower frequency converted chroma noise test signal (SP mode, burst 50mVp-p) to T74A. Input a 4MHz 300mVp-p sine wave to T74A, and a 50% white signal to T20A. Measure the burst level on T29.	490	580	670	mVp-p
PB chroma pin 72 output level	Vop-72	T74A T20A	T72	Measure the burst level with the same conditions as those for PVop-72.		280		mVp-p
PB ACC characteristics (1)	ACCP1	T74A T20A	T72	With the conditions used for PVop-29, increase the input chroma level by +6dB, measure the burst level on T72, and calculate the ratio with Vop-72.		+0.5	+0.8	dB
PB ACC characteristics (2)	ACCP2	T74A T20A	T72	With the conditions used for PVop-29, decrease the input chroma level by -6dB, measure the burst level on T72, and calculate the ratio with Vop-13.	-0.5	-0.2		dB

Continued on next page.

LA71598HM

Continued from preceding page.

Parameter	Symbol	In	Out	Conditions	Ratings			Unit
					min	typ	max	
PB killer-on input level	VACK-P	T74A T20A	T72	With the conditions used for Vop-29, the input chroma level until output from T72 cease and measure the input burst level at that point. (Calculate the ratio with the standard input 50mVp-p signal)			-25	dB
PB killer-on chroma output level	VOACK-P	T74A T20A	T29	Measure the T29 chroma output with a spectrum analyzer in the killer state of the previous item. Calculate its ratio with PVop-29.		-44	-40	dB
PB main converter carrier leakage	CLP	T74A T20A	T29	With the conditions used for PVop-29, measure the T29 with a spectrum analyzer, and calculate the ratio of the 4.43MHz component and the 5.06MHz carrier leakage component.		-40	-33	dB
PB XO output level PAL MODE	VXO-PP		T69A	In PB mode, measure the output level on T69 with an FET probe.	300	500	700	mVp-p
PB XO oscillator frequency deviation PAL MODE	$\Delta fXOP$		T69A	In PB mode, let f be the measured frequency on T69. $\Delta fXOP = f - 4433619$ (Hz)	-9	0	+9	Hz
NTSC → PAL conversion V axis Burst level	VBNAF	T1A T10A	T27	Input a chroma signal that is a lower frequency converted chroma noise test signal (SP mode, burst 100mVp-p) to T1A. Input a 4MHz 300mVp-p sine wave to T1A, and a 50% white signal to T10A. Measure the T27-45° Burst level, and take the ratio with the PVOP-27.	-2	-1	0	dB
NTSC → PAL conversion Ratio of the Burst level	ΔB -NAP	T1A T10A	T27	With the same condition above, measure the Burst level, and take the ratio with VBNAF.	-2	0	2	dB
PB Chroma 2nd harmonic distortion	PTH2	T1A T10A	T27	With the conditions used for PVOP-27, measure the T27 with a spectrum analyzer, and calculate the ratio of the 4.43MHz component and the 8.86MHz component.			-25	dB

REC/PB Mode Audio $V_{CC} = 7.5V$

Parameter	Symbol	In	Out	Conditions	Ratings			Unit
					min	typ	max	
LINE AMP voltage gain (PB)	VGLP	T100A	T96A	$V_{IN} = -30dBv$	23.0	23.5	24.0	dB
LINE AMP voltage gain (A1, A2, A3)	VGLR1 VGLR2 VGLR3	T76A T78A T80A	T96A	$V_{IN} = -30dBv$	23.0	23.5	24.0	dB
LINE AMP distortion ratio (PB)	THDL	T100A	T96A	$V_{IN} = -30dBv$	0.01	0.1	0.4	%
LINE AMP output noise voltage (PB)	VNOL	-	T96A	$R_g = 1k\Omega$, DIN Audio filter (Unweighted)	100	200	300	μV_{rms}
LINE AMP maximum output voltage (PB)	VOML	T100A	T96A	THD = 1%	1.8	2.1	2.4	Vrms
LINE AMP output level when ALC	VOA	T76A	T96A	$V_{IN} = -28dBv$	-7.0	-6.0	-5.0	dBv
LINE AMP ALC effect	ALC	T76A	T96A	$V_{IN} = -28dBv$ to $-8dBv$	0.0	1.0	3.0	dB
LINE AMP distortion ratio of when ALC	THDA	T76A	T96A	$V_{IN} = -28dBv$	0.01	0.1	0.5	%
MUTE attenuation level (PB, A1, A2, A3)	MPB MA1 MA2 MA3	T100A T76A T78A T80A	T96A	$V_{IN} = -10dBv$, MUTE-ON	80	90	120	dB
EQ AMP open loop voltage gain	VGOE	T4A	T1A	$V_{IN} = -66dBv$	58	64	70	dB
EQ AMP input conversion noise voltage	VNIE		T1A	$R_g = 620\Omega$, DIN Audio filter (Unweighted)	0.1	0.8	1.8	μV_{rms}
REC AMP voltage gain (SP)	VGRS	T98A	T7A	$V_{IN} = -20dBv$	13.5	14.0	14.5	dB
REC AMP voltage gain (LP)	VGRL	T98A	T7A	$V_{IN} = -20dBv$	13.5	14.0	14.5	dB
REC AMP distortion Ratio (LP)	THDRL	T98A	T7A	$V_{IN} = -20dBv$	0.001	0.1	0.4	%
REC AMP distortion ratio (SP)	THDRS	T98A	T7A	$V_{IN} = -20dBv$	0.001	0.1	0.4	%
REC AMP maximum output Voltage (SP)	VOMRS	T98A	T7A	THD = 1%	1.8	2.1	2.4	Vrms
Current dissipation (REC)	ICCRA			Measure the current flowing into pin 75 (No signal)	10.8	13.5	16.2	mA
Current dissipation (PB)	ICCPA			Measure the current flowing into pin 75 (No signal)	10.8	13.5	16.2	mA
DC offset voltage of MUTE-ON (PB)	MTDCO		T96	Measure the DC offset voltage on pin 96, when operating MUTE-ON (No signal)	0	30	50	mV
ALC detector input voltage	VIA	T78A	T97	$V_{IN} = -28dBv$	198	220	242	mVrms
PB attenuation level 19	PBATT19	T100A	T96A	$V_{IN} = -30dBv$, Group 8 = XX11-0010	-6.5	-6.0	-5.5	dB
PB attenuation level 28	PBATT28	T100A	T96A	$V_{IN} = -30dBv$, Group 8 = XX11-1011	-12.5	-12.0	-11.5	dB

Package Dimensions

unit: mm

3252A

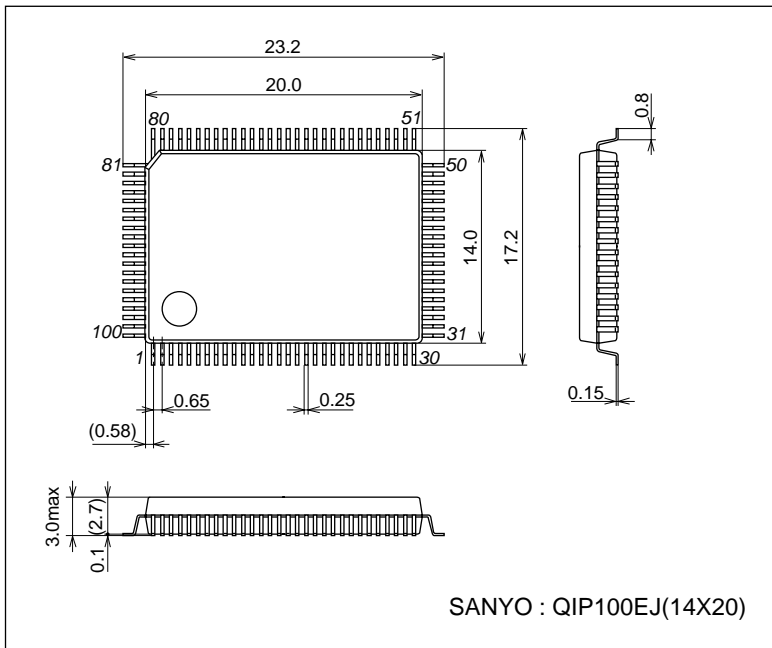

Block Diagram and Test Circuits

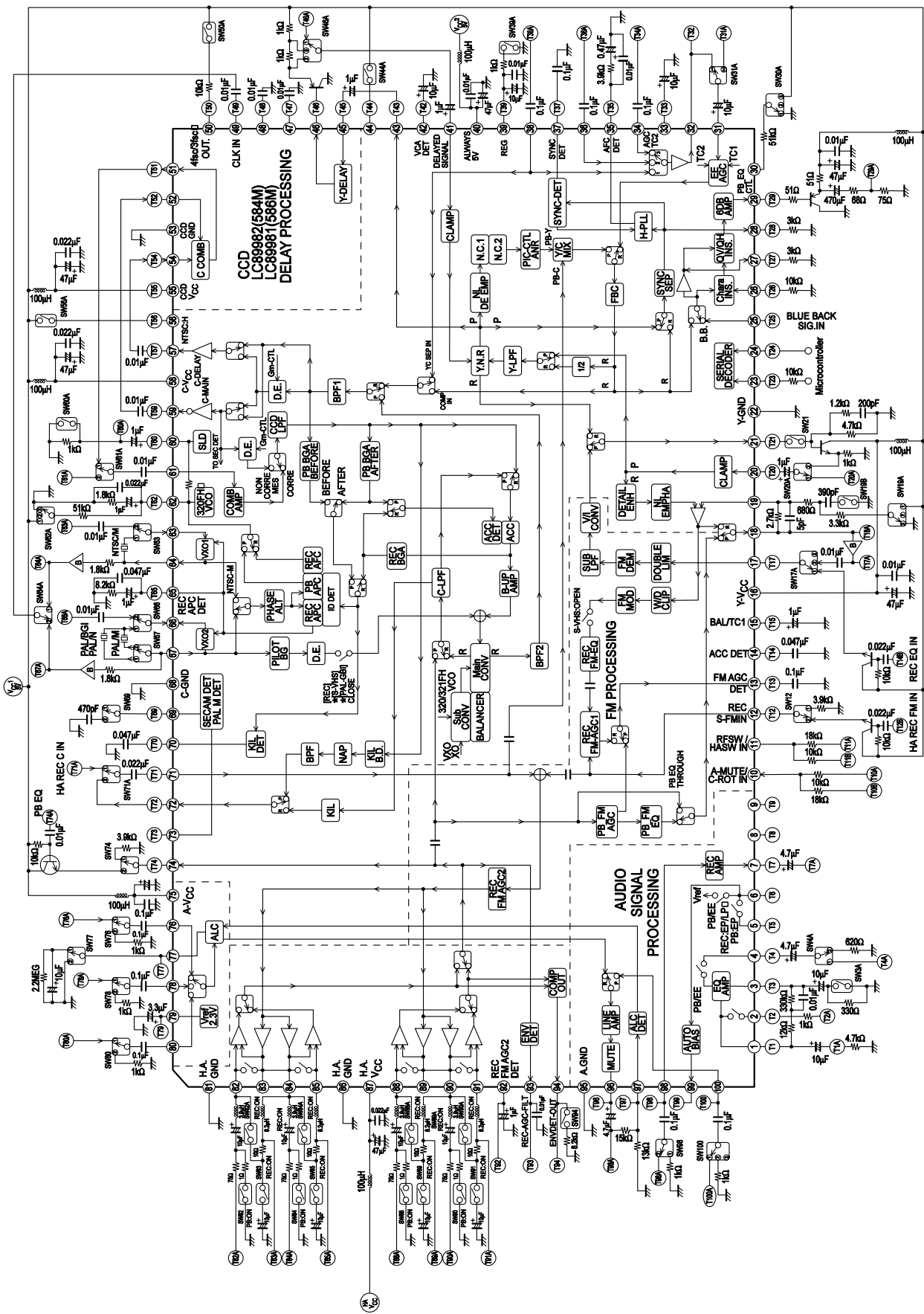

[PAL/SECAM Discrimination]

As for this IC, PAL/SECAM discrimination operates as below.

- (1) On REC/EE mode, take Hi output when input PAL-GBI signal and Lo output when input SECAM or MESECAM signal. On PB mode, takes Hi output when input PAL-GBI signal, Lo output when input MESECAM signal, and becomes unstable when input SECAM signal. But MESECAM signal when playback both LP and TRICK it takes unstable. And takes unstable all of REC/EE/PB when input PAL-M or PAL-M signal.
- (2) On NAP mode in PB, takes Hi output, and not depend on the kind of input signal.
- (3) In case of non-signal of input, takes high output except for on LP mode when Trick mode.
- (4) On REC/EE mode, takes Hi output when there are no burst or when takes smaller burst than the SPEC which shows below except for the case of above (3).
- (5) On PB mode, takes unstable output when it has smaller burst than the SPEC which shows below except for the case of above (2), (3).
- (6) It is possible to adjust small discrimination characteristics at T73. The side of high output becomes strong in case of increase T73 voltage. T73 has high sensitivity, so that we recommend to add voltage to take regulator voltage as base which receive no influence of V_{CC} changings.
- (7) T69 has high impedance, so that to set leak current lower than a few nA on P board. Insert operation Amp when monitor T69.
- (8) We dare to not recommend to PAL/SECAM discriminate to take as base for T70 voltage because of voltage get to unstable at PB MESECAM signal.

REC Mode P/S Discrimination

Parameter	Symbol	In	Out	Conditions	Ratings			Unit
					min	typ	max	
P/S discrimination minimum output level	VPSSR1	T38A	T24	Non mis-discrimination chroma burst or non-modulation carrier level when getting smaller chroma burst or non-modulation carrier of signal to input T38A. Input sync level is 300mVp-p.	10	21	29.5	mVp-p
P/S discrimination burst position	TBST	T38A	T24	Change the position of chroma burst or non-modulation carrier which is a signal input to T38A and regulate the range of non mis-discrimination as from T38A sync beginning to chroma burst or beginning of non-modulation carrier. Input sync level is 300mVp-p.	5.1	5.6	6.1	μs

PB Mode P/S Discrimination

Parameter	Symbol	In	Out	Conditions	Ratings			Unit
					min	typ	max	
R/P discrimination input level	VPSPI	T74A T20A	T24	T74A: A signal which confirmed 4MHz,300mVp-p sine wave to low band converted chroma signal. T20A: 50% white signal. Non mis-discrimination low chroma burst or non-modulation carrier level when changing the size of T74A low chroma burst or non-modulation carrier.	25	50	100	mVp-p

In Common REC/PB P/S Discrimination

Parameter	Symbol	In	Out	Conditions	Ratings			Unit
					min	typ	max	
Discrimination small adjustment center value	VPSREF		T73	The voltage of the T73.	2.3	2.5	2.7	V
P/S discrimination comparator threshold voltage when L → H	VPSLH	T69	T24	Increasing voltage the T69 from 2V, measure the T69 voltage when results of discrimination is Low.	2.81	3.01	3.21	V
P/S discrimination comparator threshold voltage when H → L	VPSHL	T69	T24	Decreasing voltage the T69 from 4V, measure the T69 voltage when results of discrimination is High.	2.51	2.71	2.91	V

CCD Block

Recommended Operating Conditions at $T_a = 25^\circ\text{C}$

Parameter	Symbol	Conditions	Ratings			Unit
			min	typ	max	
Clock input Voltage	VCLK		300	500	1000	mVp-p
Clock input frequency				4.43361875		MHz
Chrominance signal Input Voltage	V_{IN-C}			350	500	mVp-p
Luminance signal Input Voltage	V_{IN-Y}			400	572	mVp-p

Control Pin (pin 44, pin 56)

Pin57 CCD-NT-CTL	System	Chrominance signal delay time (CCD bits)	Luminance signal delay time (CCD bits)
Low	PAL/GBIN	2H (1702.5)+0H (1)	1H (848)
High	4.43NTSC	1H (844.5)+0H (1)	1H (848)

Control Voltage

Low/High	Symbol	Min	Typ	Max	Unit
Low	VL	-0.3	0.0	0.7	V
High	VH	2.0	5.0	V_{CC}	V

Description of the 3FSC Pin

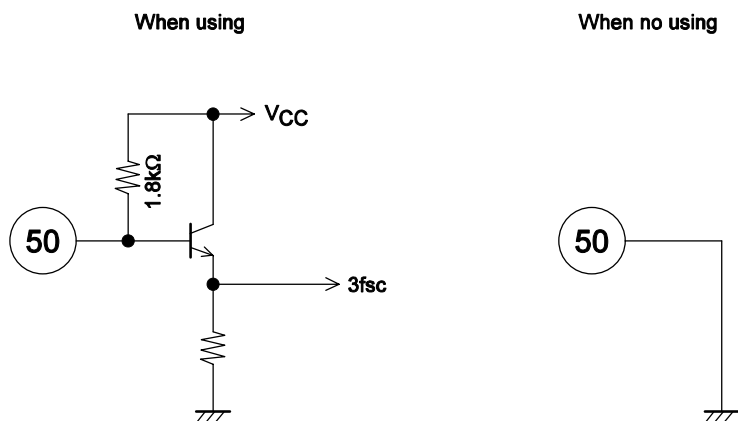

Block Diagram (CCD block)

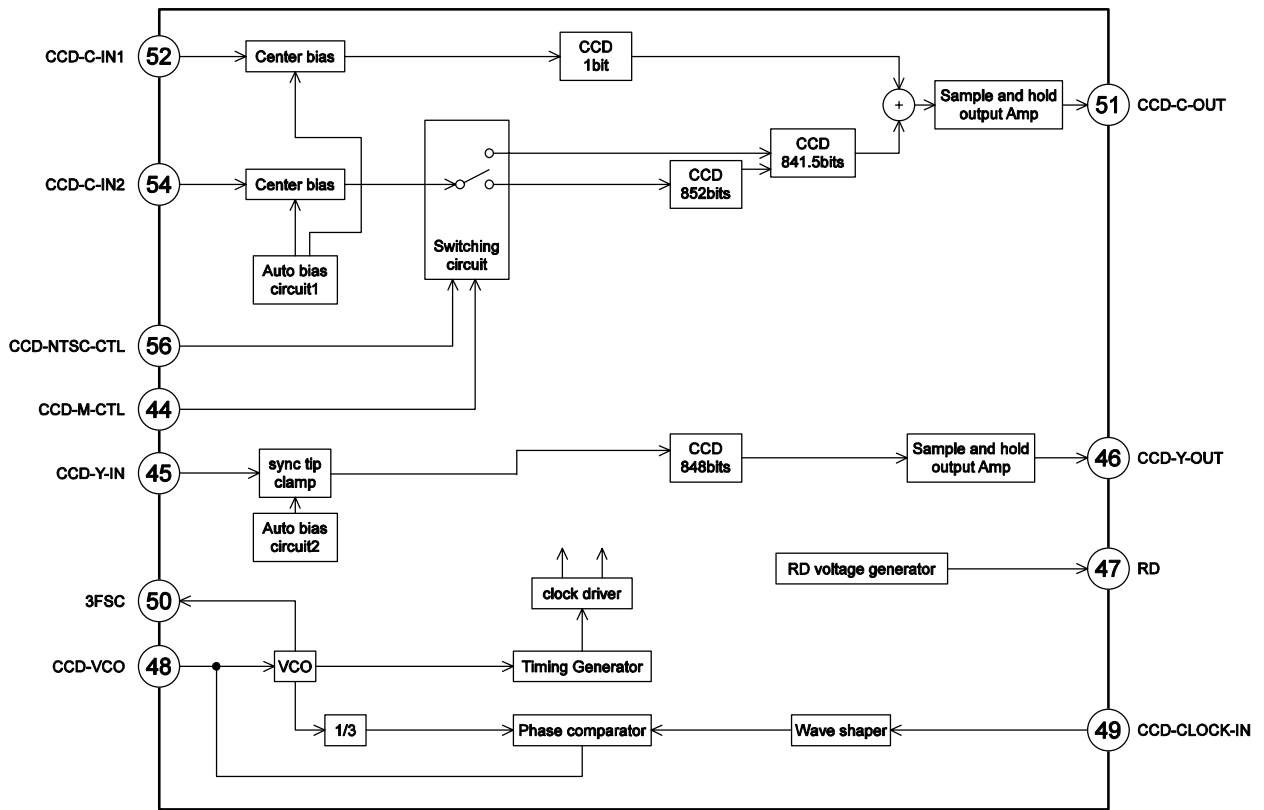

Head Amplifier

Parameter	Symbol	In	Out	Conditions			Ratings			Unit
							min	typ	max	
PB mode				T87: 5.0V T30: OPEN	T11A RF	T11B HA				
Current dissipation	IHCCP			Pin 87 inflow current	0	0		39		mA
Voltage gain			T74	$V_{IN} = 0.4mVp-p$ $F = 4MHz$						dB
SP-L CH1	Gvp1	T91A			0	0	58	60.0	62	
SP-H CH2	Gvp2	T88A			5.0	0		60.0		
EP-L CH3	Gvp3	T85A			0	5.0		60.0		
EP-H CH4	Gvp4	T82A			5.0	5.0		60.0		
Difference of voltage gain 1	$\Delta Gvp1$			Gvp1-Gvp2			-1	0	+1	dB
Difference of voltage gain 2	$\Delta Gvp2$			Gvp3-Gvp4			-1	0	+1	dB
Difference of gain between mode	$\Delta Gvp3$			Gvp3-Gvp1			-1	0	+1	dB
Frequency Characteristics			T74	$V_{IN} = 300mVp-p$ The ratio of the $V_{IN} = 38mVp-p$, $f = 7MHz$ output and Gvp1, 2, 3, 4.			-1	0	+1	dB
CH1	$\Delta Vfp1$	T91A			0	0				
CH2	$\Delta Vfp2$	T88A			5.0	0				
CH3	$\Delta Vfp3$	T85A			0	5.0				
CH4	$\Delta Vfp4$	T82A			5.0	5.0				
Secondary harmonic distortion			T74	$V_{IN} = 300mVp-p$ The ratio of 8MHz (second component) of the $V_{IN} = 38mVp-p$, $f = 4MHz$ output and 4MHz (first component).					-40	dB
CH1	VHDP1	T91A			0	0				
CH2	VHDP2	T88A			5.0	0				
CH3	VHDP3	T85A			0	5.0				
CH4	VHDP4	T82A			5.0	5.0				
Maximum output level			T74	As $f = 1MHz$, the output level of which become -30dB as the ratio of output 3MHz (third component) and 1MHz (first component).			1.0	1.2		Vp-p
CH1	VOMP1	T82A			0	0				
CH2	VOMP2	T85A			5.0	0				
CH3	VOMP3	T88A			0	5.0				
CH4	VOMP4	T91A			5.0	5.0				
Cross talk SP1 CH1	VCR1	T82A T85A T88A	T74	The ratio of output of $V_{IN} = 38mVp-p$, $f = 4MHz$ and Gvp1.	0	0			-35	dB
Cross talk SP2 CH2	VCR2	T82A T85A T91A	T74	The ratio of output of $V_{IN} = 38mVp-p$, $f = 4MHz$ and Gvp2.	5.0	0			-35	dB
Cross talk EP1 CH3	VCR3	T82A T88A T91A	T74	The ratio of output of $V_{IN} = 38mVp-p$, $f = 4MHz$ and Gvp3.	0	5.0			-35	dB
Cross talk EP2 CH4	VCR4	T85A T88A T91A	T74	The ratio of output of $V_{IN} = 38mVp-p$, $f = 4MHz$ and Gvp4.	5.0	5.0			-35	dB
Equivalent input noise voltage			T74	90 connected to 91 88 89 84 85 82 83	0 5 0 5	0 0 5 5		0.6	0.2	hV/\sqrt{Hz}
Equivalent input current noise			T74	90, 91 open 88, 89 84, 85 82, 83	0 5 0 5	0 0 5 5		1.7	2.0	pA/\sqrt{Hz}

Continued on next page.

Continued from preceding page.

Parameter	Symbol	In	Out	Conditions			Ratings			Unit
							min	typ	max	
Output DC off set	Δ VODC1		T74	CH1- CH2	0 5.0	0 0	-150	0	+150	mV
	Δ VODC2			CH3- CH4	0 5.0	5.0 5.0				
	Δ VODC3			CH1- CH3	0 0	0 5.0				
	Δ VODC4			CH2- CH4	5.0 5.0	0 5.0				
	Δ VODC5			CH1- CH4	0 5.0	0 5.0				
	Δ VODC6			CH2- CH3	0 5.0	0 5.0				
PB mode				T87: 5.0V T30: OPEN	T11A RF	T11B HA				
Envelope detection output terminal voltage	VENV		T93	T93 DC when no input.	0	0		0.8	1.0	V
Envelope detection output terminal voltage SP1	VENV1	T91A	T93	When input f = 4MHz, T93 175mVp-p, DC dif to venv, for T74 output level.	0.0	0.0	2.0	2.5	3.0	V
Envelope detection output terminal voltage SP2	VENV4	T91A	T93	When input f = 4MHz, T93 400mVp-p, for T74 output level.	0.0	5.0	4.0	4.5	5.0	V
Envelope detection output terminal voltage EP1	VENV6	T85A	T93	When input f = 4MHz, T93 125mVp-p, for T74 output level.	5.0	0.0	2.0	2.5	3.0	V
Envelope detection output terminal voltage EP2	VENV7	T85A	T93	When input f = 4MHz, T93 300mVp-p DC dif to venv.	5.0	5.0	3.5	4.0	4.5	V
Comparator output voltage 1	VCOMP1	T91A	T94	T94 DC voltage when $V_{IN} = 38mVp-p$, f = 4MHz.	0	0		0.4	0.7	V
Comparator output voltage 2	VCOMP2	T85A	T94	T94DC voltage when $V_{IN} = 38mVp-p$, f = 4MHz.	5.0	0	4.5	4.8		V

Continued on next page.

For operating the RF-SW and HA-SW, it's necessary to input the video signal to T20A.
And also confirm the output signal of T28.

Continued from preceding page.

Parameter	Symbol	In	Out	Conditions		Ratings			Unit
						min	typ	max	
Recording mode				T87: 5.0V T30: 5.0V	T11B HA				
Current dissipation	IHCCR			Pin 87 inflow current.	0		48		mA
REC AGC Amp output current	VRSP VREP	T12A	T89A T83A	Output level when $V_{IN} = 300\text{mVp-p}$, $f = 4\text{MHz}$	0 5.0	12.7	13.5	14.3	mAp-p
REC AGC AMP control characteristics 1	$\Delta VAGC1\text{-SP}$ $\Delta VAGC1\text{-EP}$	T12A	T89A T83A	As $f = 4\text{MHz}$, the output level/VRSP, EP When $V_{IN} = 700\text{mVp-p}$.	0 5.0		0.5		dB
REC AGC AMP control characteristics 2	$\Delta VAGC2\text{-SP}$ $\Delta VAGC2\text{-EP}$	T12A	T89A T83A	As $f = 4\text{MHz}$, the output Level/VRSP, EP when $V_{IN} = 100\text{mVp-p}$.	5.0		-0.5		dB
REC AGC AMP Frequency characteristics	$\Delta VF\text{RS}$ $\Delta VF\text{RE}$	T12A	T89A T83A	As $V_{IN} = 300\text{mVp-p}$, the output ratio when f is 1M, 7MHz 7MHz/1MHz (Note 1)	0 5.0		0.0		dB
REC AGC AMP second harmonic distortion	$\Delta V\text{HDRS}$ $\Delta V\text{HDRE}$	T12A	T89A T83A	15mAp-p/ each head The ratio of the 8M (second component) $V_{IN} = 300\text{mVp-p}$, $f = 4\text{MHz}$ output and 4M (first component).	0 5.0		-40	-36	dB
REC AGC AMP maximum output level	$\Delta V\text{HDRS}$ $\Delta V\text{HDRE}$	T12A	T89A T83A	The output level which become -35dB of $f = 4\text{MHz}$ second distortion.	0 5.0		2.0		mAp-p
REC AGC AMP attenuate volume of mute	$\Delta VM\text{RS}$ $\Delta VM\text{RE}$	T12A	T89A T83A	Output level/VRSP, EP When $V_{IN} = 300\text{mVp-p}$, $f = 4\text{MHz}$ via pin 30	0 5.0		-45		dB
REC AGC AMP Mixed modulation relative level	$\Delta VC\text{YS}$ $\Delta VC\text{YE}$	T12A, T71A	T89A T83A	T12A: $V_{IN} = 300\text{mVp-p}$, $f = 4\text{MHz}$, T71A: $V_{IN} = 1.5\text{Vp-p}$, $f = 629\text{kHz}$ (4M±629K)/4M ratio of output	0 5.0		-40		dB

Similarly to the case of the PB mode, HA-SW (EP/SP) changeover is synchronized to rise of H-SYNC in the REC mode. Before changeover,

Check by applying the video signal (Vp-p) to T38A if H-SYNC is correctly output to T28.

(Note1) Apply about 1.8 DC volt to the AGC detection filter pin (pin92) to fix AGC-AMP-GAIN

Note 1. To measure REC-AGC-AMP, C-sync must be fixed to HIGH. Connect T38A, T36A, and T34A of the VIDEO input pin to ground in the REC mode

2. Use a resistor of pin 74 to ground with the accuracy of ±1.0%

For operating the HA-SW, it's necessary to input the video signal to T20A.

And also confirm the output signal of T28.

Pin Functions

Pin No.	Pin name	DC voltage	Signal wave form	Input/Output form
1	EQ-OUT	REC: A-V _{CC} /2		
		PB: A-V _{CC} /2	CW: 95mVp-p	
2	EQ-SW2	REC: A-V _{CC} /2		
		PB: A-V _{CC} /2	CW: 95mVp-p	
3	EQ-NFB	REC: A-V _{CC} /2		
		PB: A-V _{CC} /2	CW: 1mVp-p	
4	EQ-IN	REC: A-V _{CC} /2		
		PB: A-V _{CC} /2	CW: 1mVp-p	
5	EQ-SW1	REC: A-V _{CC} /2	CW: 1.4Vp-p +70kHz: 850mVp-p	
		PB: A-V _{CC} /2	SP/LP: IMAGINATION GND EP: CW: 1mVp-p	
6	AUTO-BIAS-IN	REC: A-V _{CC} /2	CW: 1.4Vp-p +70kHz: 850mVp-p	
	PB-GND-SW	PB: A-V _{CC} /2	IMAGINATION GND	
7	AUDIO-REC-OUT	REC: A-V _{CC} /2	CW: 1.4Vp-p	
		PB: A-V _{CC} /2		
8	AUDIO REC-NFB-SP AUDIO REC-NFB-LP, EP	REC: A-V _{CC} /2	CW: 280mVp-p	
PB: A-V _{CC} /2				

Continued on next page.

LA71598HM

Continued from preceding page.

Pin No.	Pin name	DC voltage	Signal wave form	Input/Output form
10	MUTE C-ROT	C-ROT L → 0° (PAL) H → 90°/H		
11	RF-SW HA-SW			
12	PORECEQ	REC: 2.0V PB: 4.2V	FM: 350mVp-p	
13	FM-AGC-FILT	REC: 1.5V PB: 1.5V		
14	ACC-FILT	REC: 1.7V PB: 1.5V	DC	

Continued on next page.

LA71598HM

Continued from preceding page.

Pin No.	Pin name	DC voltage	Signal wave form	Input/Output form
15	REC-AGC-TC1	REC: 2.2V	DC	
	PB BALANCER	PB: 2.2V	DC	
16	Y- V_{CC-5V}	5V	DC	
17	PB-FM-IN2	REC: 0.05V	PB-Y-FM 	
		PB: 3V		
18	EMPHASIS-OUT	REC: 2.1V		
		PB: 1.8V		
19	MAIN-EMPHAFILT	REC: 2.1V		
		PB: 2.1V		

Continued on next page.

LA71598HM

Continued from preceding page.

Pin No.	Pin name	DC voltage	Signal wave form	Input/Output form
20	CLAMP-IN	REC: 2.8V		
		PB: 2.8V		
21	MAIN-DEEMPHA-OUT	REC: 2.1V		
		PB: 2.1V		
22	Y-GND			
23	SERIAL DATA-IN	REC:		
		PB:		
24	SERIAL CLOCK-IN	REC:		
		PB:		
25	BLUE-BACK-IN	REC: 1.8V		
		PB: 1.8V		

Continued on next page.

LA71598HM

Continued from preceding page.

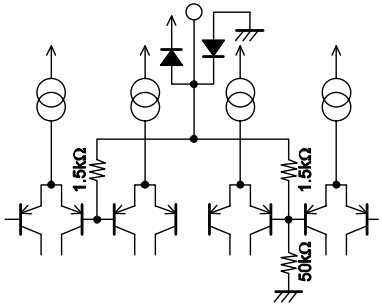
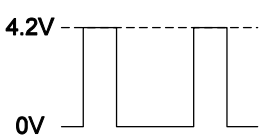
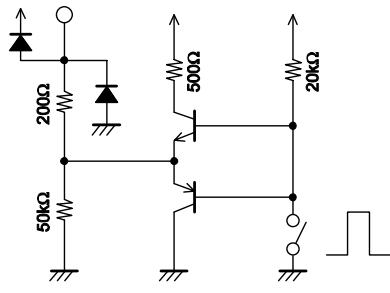
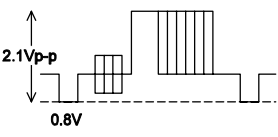
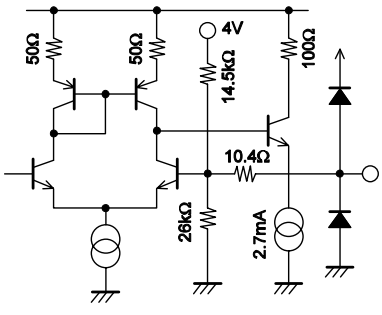
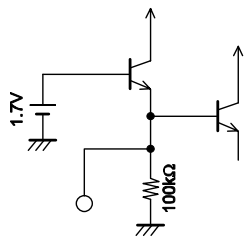
Pin No.	Pin name	DC voltage	Signal wave form	Input/Output form
26	QV/QH-INS	REC: 0.0V PB:	0 to 0.8V: THROUGH 1.2 to 1.8V: BLACK INS 2.4 to 2.8V: WHITE HIS 3.4 to 3.8V: BLACK INS 3.9 to V _{CC} : QV INS	
27 28	H.SYNC-OUT C.SYNC-OUT	REC: PB:		
29	VIDEO-OUT	REC: SYNC 0.8V PB: SYNC 0.8V		
30	PEQCTL	REC: 0 or 5V PB: 1.0V		

Continued on next page.

LA71598HM

Continued from preceding page.

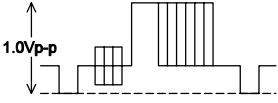
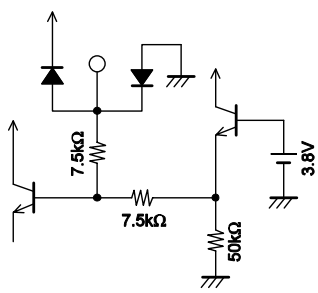
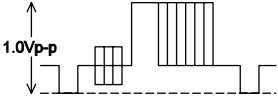
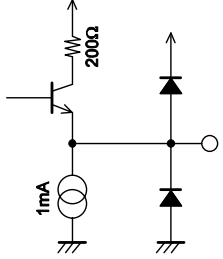
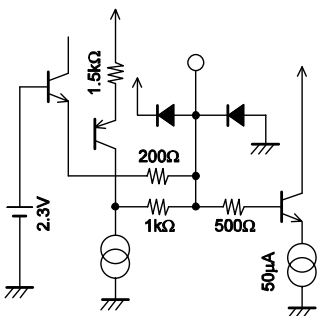
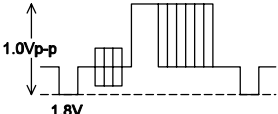
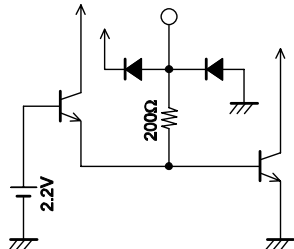
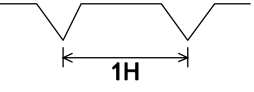
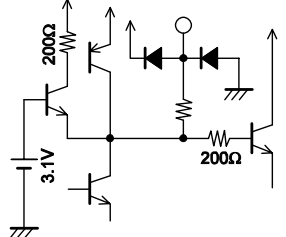
Pin No.	Pin name	DC voltage	Signal wave form	Input/Output form
31	VIDEO-AGC-IN	REC: 2.1V		
		PB: 2.1V		
32	VIDEO-SW-OUT	REC: 1.8V		
		PB: 1.8V		
33	AGC-TC2	REC: 2.0V	DC	
		PB: 2.0V	DC	
34 36 38	VIDEO-IN3 VIDEO-IN2 VIDEO-IN1	REC: 1.8V		
PB: 1.8V				
35	AFC2-FILT	REC: 3.5V		
		PB: 3.5V		

Continued on next page.

LA71598HM

Continued from preceding page.

Pin No.	Pin name	DC voltage	Signal wave form	Input/Output form
37	SYNC DET-FILT	REC: 4.9V NO-SIG.: 0.3V	DC	
		PB: 4.9V NO-SIG.: 0.3V	DC	
39	REG4.0	REC: 4V	DC	
		PB: 4V		
40	ALWAYS-5V	5.0V	DC	
41	1HDL-IN	REC: 2.7V		
		PB: 2.7V		
42	VCA-FILT	REC: 3.0		
		PB: 1.9		
43	VCA-OUT	REC: 1.9V		
		PB: 1.9		

Continued on next page.

LA71598HM

Continued from preceding page.

Pin No.	Pin name	DC voltage	Signal wave form	Input/Output form
44	PB H OUT	REC/PB	DC M(60Hz): High 4.3V Expect above: Low * Selected 4.43 only mode PB mode: High	
45	CCD-Y-IN	REC: 1.8V		
		PB: 1.8V		
46	CCD-Y-OUT			
47	RD	REC: 2.0V	DC	
		PB: 2.0V	DC	
48	CCD-VCO FILT	REC: 2.3V	DC	
		PB: 2.3V	DC	
49	CCD-CLOCK- IN	REC: 1.2V		
		PB: 1.2V		

Continued on next page.

LA71598HM

Continued from preceding page.

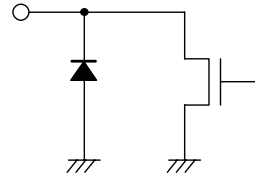
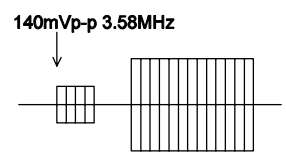
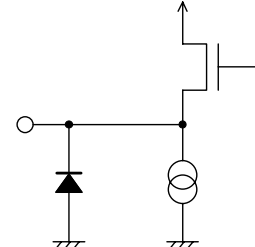
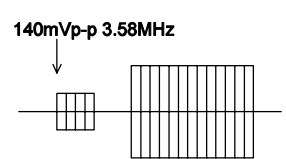
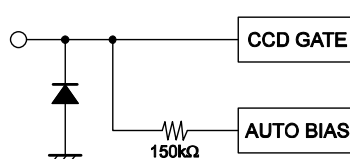
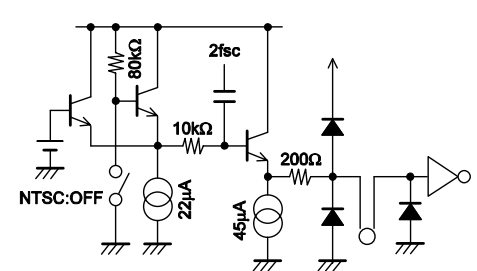
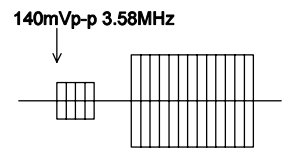
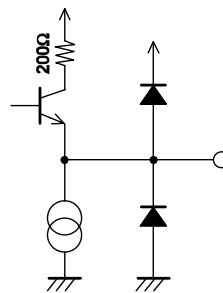
Pin No.	Pin name	DC voltage	Signal wave form	Input/Output form
50	3FSC-OUT		900mVp-p	
51	CCD-C-OUT	REC: 1.9V PB: 1.9V	140mVp-p 3.58MHz 	
52 54	CCD-C-IN1 CCD-C-IN2	REC: 2.4V PB: 2.4V	140mVp-p 3.58MHz 	
53	CCD-GND			
55	CCD-V _{CC} -5V	5.0V	DC	
56	CCD-NT-CTL +2fsc-OUT	REC/PB	DC NTSC: High 3.5V Excepted above: Low (0.5V)	
57 59	C-DL-OUT C-0H-OUT	REC: 3.4V PB: 3.4V	140mVp-p 3.58MHz 	
58	C-V _{CC} -5V	5.0V	DC	

Continued on next page.

LA71598HM

Continued from preceding page.

Pin No.	Pin name	DC voltage	Signal wave form	Input/Output form
60	SLD-FILT	REC: 3.5V	DC	
		PB: 3.5V	DC	
61	A-COMB-IN	REC: 3.3V		
		PB: 3.3V		
62	AFC/APC-FILT	REC: 3.5V		See pin 60
		PB: 3.5V		
63	VXO/XO-IN1 3.58M NTSC	REC: 4.0V		
		PB: 4.0V		
64 66	VXO/XO- OUT1 VXO/XO- OUT2	REC: 2.2V		
		PB: 2.2V		

Continued on next page.

LA71598HM

Continued from preceding page.

Pin No.	Pin name	DC voltage	Signal wave form	Input/Output form
65	REC APC-FILT	REC: 2.4V	DC	
		PB: 2.4V	DC	
67	VXO/XO-IN1 PAL/BGI. M.N	REC: 4.0V		
		PB: 4.0V		
68	C-GND			
69	P/S-DET-FILT (PAL_M_DET_FILT)	REC	DC SECAM/MESECAM: High 4.0V Except above: Low 2.0V * Selected C358 mode PAL_M_DET Wrong CTL: High	
		PB	DC MESECAM: High 4.0V Except above: Low 2.0V * Selected C358 mode PAL_M_DET Wrong CTL: High	
70	KILL-FILT	REC: 2.0V	DC	
		PB: 2.0V	DC	

Continued on next page.

LA71598HM

Continued from preceding page.

Pin No.	Pin name	DC voltage	Signal wave form	Input/Output form
71	PIREC-C	REC: 2.5V	REC chroma	
		PB: 2.5V	PB chroma	
72	REC-C-OUT	REC: 2.5V	<p>380mVp-p 629MHz SP/EP (bit=0.0)</p>	
		PB: 0.3V	3.2V to V _{CC} : Change the Sync-sep. Slice level	
73	P/S-DET-CTL (PAL-M-DET-CTL)	REC: 2.5V		
		PB: 2.5V		
74	POPBFMMN			
		PB: 2.0V	FM 300mVp-p	
75	A-V _{CC}	5.0V	DC	
76	AUDIO-IN1	REC: 2.5V	CW: 95mVp-p	
78	AUDIO-IN2			
80	AUDIO-IN3			
		PB: 2.5V		

Continued on next page.

LA71598HM

Continued from preceding page.

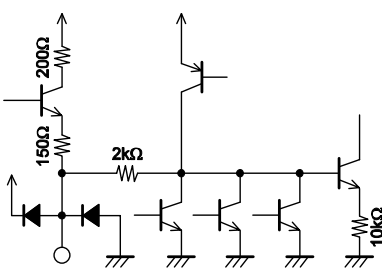
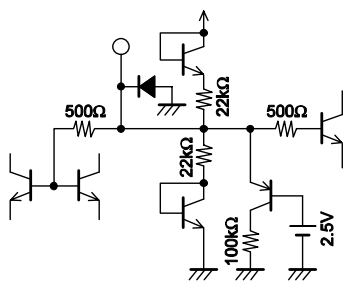
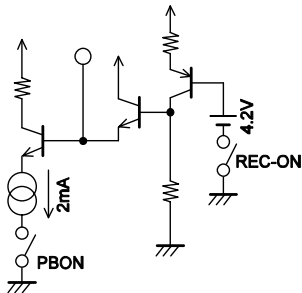
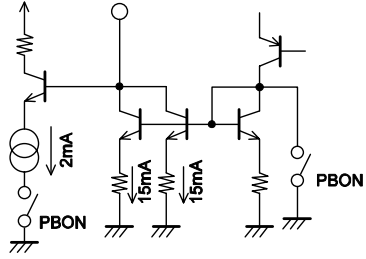
Pin No.	Pin name	DC voltage	Signal wave form	Input/Output form
77	ALC-DET-	REC: 0V	Detected DC voltage	
		PB: 0V		
79	VREF	REC: 2.5V	DC	
		PB: 2.5V	DC	
81 83 86 89	H.A GND			
82 91	PIPBSP+ PIPBFPH+	REC: 3.9V	0.5mVp-p	
		PB: 1.8V		
84 90	PIPBSP- PIPBEP-	REC: 3.9V	13mA _{p-p}	
		PB: 1.8V	0.5mVp-p	

Continued on next page.

LA71598HM

Continued from preceding page.

Pin No.	Pin name	DC voltage	Signal wave form	Input/Output form
85 88	PIPBSPH+ PIPBEPL+	REC: 3.9V PB: 1.8V	0.5mVp-p	
87	H.A V _{CC}	5.0V	DC	
92	PHRDFTL	REV: 1.6V PB:	DC	
93	POENVDET	REC: PB: 0.5 to 4.9V	DC	
94	PIRADJI	REC: 0.7V PB: When Trick 0.5V or 4.5V	FM 500mVp-p HASW control DC output in trick mode	
95	A.GND			

Continued on next page.

LA71598HM

Continued from preceding page.

Pin No.	Pin name	DC voltage	Signal wave form	Input/Output form
96	AUDIO LINE-OUT	REC: 2.5V (3.75V)	CW: 1.4Vp-p	
		PB: 2.5V (3.75V)	CW: 1.4Vp-p	
97	ALC-IN	REC: 0.0V	CW: 700mVp-p	
		PB: 0.0V		
98	AUDIO-REC-IN	REC: 2.5V (3.75V)	CW: 280mVp-p	
		PB: 2.5V (3.75V)		
99	AUTO-BIAS-OUT	REC: 4.3V	DC	
		PB: 5.0V (7.5V)		
100	AUDIO-PB-IN	REC: 2.5V (3.75V)	Half-wave rectified waveform +2.5V (70kHz)	
		PB: 2.5V (3.75V)	CW: 95mVp-p	

Continued on next page.

Mode Table REC-Y

No.	Parameter	12	17A	19A	19B	20A	21	30A	31A	39A	44	46A	50A	56A	60A	61A	62A	63	64A	66	67	69	71A	74	Gr.1	Gr.2	Gr.3	Gr.4	Gr.5	Gr.6	Gr.7	Gr.8		
1	Current dissipation REC	↓	↓	↓	↓	↓	↓	↓	↓	↓	↓	↓	↓	↓	↓	↓	↓	↓	↓	↓	↓	↓	↓	↓	↓	↓	↓	↓	↓	↓	↓	↓		
2	EE output level 1	↓	↓	↓	↓	↓	↓	↓	↓	↓	↓	↓	↓	↓	↓	↓	↓	↓	↓	↓	↓	↓	↓	↓	0000 1101	0000 1101	0000 1010	0100 0000	0110 1000	1000 0101	0011 0100	0011 0000		
3	EE output level 2	↓	↓	↓	↓	↓	↓	↓	↓	↓	↓	↓	↓	↓	↓	↓	↓	↓	↓	↓	↓	↓	↓	↓	0000 1100	0000 1100	↓	↓	↓	↓	↓	↓		
4	EE output level 3	↓	↓	↓	↓	↓	↓	↓	↓	↓	↓	↓	↓	↓	↓	↓	↓	↓	↓	↓	↓	↓	↓	↓	0010 0100	0000 1100	↓	↓	↓	↓	↓	↓		
5	AGC characteristics 1	↓	↓	↓	↓	↓	↓	↓	↓	↓	↓	↓	↓	↓	↓	↓	↓	↓	↓	↓	↓	↓	↓	↓	0010 1000	↓	↓	↓	↓	↓	↓	↓		
6	AGC characteristics 2	↓	↓	↓	↓	↓	↓	↓	↓	↓	↓	↓	↓	↓	↓	↓	↓	↓	↓	↓	↓	↓	↓	↓	0010 0000	0000 1101	↓	↓	↓	↓	↓	↓		
7	AGC characteristics 3	↓	↓	↓	↓	↓	↓	↓	↓	↓	↓	↓	↓	↓	↓	↓	↓	↓	↓	↓	↓	↓	↓	↓	↓	↓	↓	↓	↓	↓	↓	↓		
8	AGC characteristics 4	↓	↓	↓	↓	↓	↓	↓	↓	↓	↓	↓	↓	↓	↓	↓	↓	↓	↓	↓	↓	↓	↓	↓	↓	↓	↓	↓	↓	↓	↓	↓		
9	Sync. separator output level	↓	↓	↓	↓	↓	↓	↓	↓	↓	↓	↓	↓	↓	↓	↓	↓	↓	↓	↓	↓	↓	↓	↓	↓	↓	↓	↓	↓	↓	↓	↓	↓	
10	Sync. separator output pulse width	↓	↓	↓	↓	↓	↓	↓	↓	↓	↓	↓	↓	↓	↓	↓	↓	↓	↓	↓	↓	↓	↓	↓	↓	↓	↓	↓	↓	↓	↓	↓	↓	
11	Sync. separator threshold level	↓	↓	↓	↓	↓	↓	↓	↓	↓	↓	↓	↓	↓	↓	↓	↓	↓	↓	↓	↓	↓	↓	↓	↓	↓	↓	↓	↓	↓	↓	↓	↓	
12	H Sync. Output level	↓	↓	↓	↓	↓	↓	↓	↓	↓	↓	↓	↓	↓	↓	↓	↓	↓	↓	↓	↓	↓	↓	↓	↓	↓	↓	↓	↓	↓	↓	↓	↓	
13	H Sync. Output pulse width	↓	↓	↓	↓	↓	↓	↓	↓	↓	↓	↓	↓	↓	↓	↓	↓	↓	↓	↓	↓	↓	↓	↓	↓	↓	↓	↓	↓	↓	↓	↓	↓	↓
14	Sync. tip level/pedestal level/white level	↓	↓	↓	↓	↓	↓	↓	↓	↓	↓	↓	↓	↓	↓	↓	↓	↓	↓	↓	↓	↓	↓	↓	↓	↓	↓	↓	↓	↓	↓	↓	↓	↓
15	Quasi-V insertion level	↓	↓	↓	↓	↓	↓	↓	↓	↓	↓	↓	↓	↓	↓	↓	↓	↓	↓	↓	↓	↓	↓	↓	↓	↓	↓	↓	↓	↓	↓	↓	↓	↓
16	Quasi-H insertion level	↓	↓	↓	↓	↓	↓	↓	↓	↓	↓	↓	↓	↓	↓	↓	↓	↓	↓	↓	↓	↓	↓	↓	↓	↓	↓	↓	↓	↓	↓	↓	↓	↓
17	White insertion level	↓	↓	↓	↓	↓	↓	↓	↓	↓	↓	↓	↓	↓	↓	↓	↓	↓	↓	↓	↓	↓	↓	↓	↓	↓	↓	↓	↓	↓	↓	↓	↓	↓
18	Edge insertion level	↓	↓	↓	↓	↓	↓	↓	↓	↓	↓	↓	↓	↓	↓	↓	↓	↓	↓	↓	↓	↓	↓	↓	↓	↓	↓	↓	↓	↓	↓	↓	↓	↓
19	REC-YNR operation	↓	↓	↓	↓	↓	↓	↓	↓	↓	↓	↓	↓	↓	↓	↓	↓	↓	↓	↓	↓	↓	↓	↓	↓	↓	↓	↓	↓	↓	↓	↓	↓	↓
20	Y-LPF frequency characteristics 1	↓	↓	↓	↓	↓	↓	↓	↓	↓	↓	↓	↓	↓	↓	↓	↓	↓	↓	↓	↓	↓	↓	↓	↓	↓	↓	↓	↓	↓	↓	↓	↓	↓
21	Y-LPF frequency characteristics 2	↓	↓	↓	↓	↓	↓	↓	↓	↓	↓	↓	↓	↓	↓	↓	↓	↓	↓	↓	↓	↓	↓	↓	↓	↓	↓	↓	↓	↓	↓	↓	↓	↓
22	Y-LPF frequency characteristics 3	↓	↓	↓	↓	↓	↓	↓	↓	↓	↓	↓	↓	↓	↓	↓	↓	↓	↓	↓	↓	↓	↓	↓	↓	↓	↓	↓	↓	↓	↓	↓	↓	↓
23	Y-LPF frequency characteristics 4	↓	↓	↓	↓	↓	↓	↓	↓	↓	↓	↓	↓	↓	↓	↓	↓	↓	↓	↓	↓	↓	↓	↓	↓	↓	↓	↓	↓	↓	↓	↓	↓	↓
24	Y-LPF frequency characteristics 5	↓	↓	↓	↓	↓	↓	↓	↓	↓	↓	↓	↓	↓	↓	↓	↓	↓	↓	↓	↓	↓	↓	↓	↓	↓	↓	↓	↓	↓	↓	↓	↓	↓
25	REC-FM output level	↓	↓	↓	↓	↓	↓	↓	↓	↓	↓	↓	↓	↓	↓	↓	↓	↓	↓	↓	↓	↓	↓	↓	↓	↓	↓	↓	↓	↓	↓	↓	↓	↓
26	Carrier frequency 1	↓	↓	↓	↓	2	↓	↓	↓	↓	↓	↓	↓	↓	↓	↓	↓	↓	↓	↓	↓	↓	↓	↓	↓	↓	↓	↓	↓	↓	↓	↓	↓	↓
27	REC-FM output 2nd distortion	↓	↓	↓	↓	↓	↓	↓	↓	↓	↓	↓	↓	↓	↓	↓	↓	↓	↓	↓	↓	↓	↓	↓	↓	↓	↓	↓	↓	↓	↓	↓	↓	↓
28	Deviation	↓	↓	↓	↓	↓	↓	↓	↓	↓	↓	↓	↓	↓	↓	↓	↓	↓	↓	↓	↓	↓	↓	↓	↓	0000 1101	0000 1101	↓	↓	↓	↓	↓	↓	
29	White peak frequency	↓	↓	↓	↓	↓	↓	↓	↓	↓	↓	↓	↓	↓	↓	↓	↓	↓	↓	↓	↓	↓	↓	↓	↓	0000 1100	0000 1100	↓	↓	↓	↓	↓	↓	
30	FM modulator linearity	↓	↓	↓	↓	↓	↓	↓	↓	↓	↓	↓	↓	↓	↓	↓	↓	↓	↓	↓	↓	↓	↓	↓	↓	0000 1101	0000 1101	↓	↓	↓	↓	↓	↓	
31	1/2H carrier shift	↓	↓	↓	↓	↓	↓	↓	↓	↓	↓	↓	↓	↓	↓	↓	↓	↓	↓	↓	↓	↓	↓	↓	↓	↓	↓	↓	↓	↓	↓	↓	↓	↓
32	Emphasis gain	↓	↓	↓	↓	↓	↓	↓	↓	↓	↓	↓	↓	↓	↓	↓	↓	↓	↓	↓	↓	↓	↓	↓	↓	↓	↓	↓	↓	↓	↓	↓	↓	↓
33	Detail enhancer characteristics 1	↓	↓	↓	↓	↓	↓	↓	↓	↓	↓	↓	↓	↓	↓	↓	↓	↓	↓	↓	↓	↓	↓	↓	↓	↓	↓	↓	↓	↓	↓	↓	↓	↓
34	Detail enhancer characteristics 2	↓	↓	↓	↓	↓	↓	↓	↓	↓	↓	↓	↓	↓	↓	↓	↓	↓	↓	↓	↓	↓	↓	↓	↓	↓	↓	↓	↓	↓	↓	↓	↓	↓
35	Detail enhancer characteristics 3	↓	↓	↓	↓	↓	↓	↓	↓	↓	↓	↓	↓	↓	↓	↓	↓	↓	↓	↓	↓	↓	↓	↓	↓	↓	↓	↓	↓	↓	↓	↓	↓	↓
36	Nonlinear emphasis characteristics 1	↓	↓	↓	↓	↓	↓	↓	↓	↓	↓	↓	↓	↓	↓	↓	↓	↓	↓	↓	↓	↓	↓	↓	↓	↓	↓	↓	↓	↓	↓	↓	↓	↓
37	Nonlinear emphasis characteristics 2	↓	↓	↓	↓	↓	↓	↓	↓	↓	↓	↓	↓	↓	↓	↓	↓	↓	↓	↓	↓	↓	↓	↓	↓	↓	↓	↓	↓	↓	↓	↓	↓	↓
38	Nonlinear emphasis characteristics 3	↓	↓	↓	↓	↓	↓	↓	↓	↓	↓	↓	↓	↓	↓	↓	↓	↓	↓	↓	↓	↓	↓	↓	↓	↓	↓	↓	↓	↓	↓	↓	↓	↓
39	Main linear emphasis characteristics 1	↓	↓	↓	↓	↓	↓	↓	↓	↓	↓	↓	↓	↓	↓	↓	↓	↓	↓	↓	↓	↓	↓	↓	↓	↓	↓	↓	↓	↓	↓	↓	↓	↓
40	Main linear emphasis characteristics 2	↓	↓	↓	↓	↓	↓	↓	↓	↓	↓	↓	↓	↓	↓	↓	↓	↓	↓	↓	↓	↓	↓	↓	↓	↓	↓	↓	↓	↓	↓	↓	↓	↓
41	White clipping level	↓	↓	↓	↓	↓	↓	↓	↓	↓	↓	↓	↓	↓	↓	↓	↓	↓	↓	↓	↓	↓	↓	↓	↓	↓	↓	↓	↓	↓	↓	↓	↓	↓
42	Dark clipping level	↓	↓	↓	↓	↓	↓	↓	↓	↓	↓	↓	↓	↓	↓	↓	↓	↓	↓	↓	↓	↓	↓	↓	↓	↓	↓	↓	↓	↓	↓	↓	↓	↓

PB-Y

No.	Parameter	12	17A	19A	19B	20A	21	30A	31A	39A	44	46A	50A	56A	60A	61A	62A	63	64A	66	67	69	71A	74	Gr.1	Gr.2	Gr.3	Gr.4	Gr.5	Gr.6	Gr.7	Gr.8			
1	Current dissipation (PB)	↓	↓	↓	↓	↓	↓	↓	↓	↓	↓	↓	↓	↓	↓	↓	↓	↓	↓	↓	↓	↓	↓	↓	↓	↓	↓	↓	↓	↓	↓	↓	↓		
2	Dropout compensation period	↓	↓	↓	↓	↓	↓	↓	↓	↓	↓	↓	↓	↓	↓	↓	↓	↓	↓	↓	↓	↓	↓	↓	↓	↓	↓	↓	↓	↓	↓	↓	↓		
3	DOC characteristics	↓	↓	↓	↓	↓	↓	↓	↓	↓	↓	↓	↓	↓	↓	↓	↓	↓	↓	↓	↓	↓	↓	↓	↓	↓	↓	↓	↓	↓	↓	↓	↓		
4	PB-Y level	↓	↓	↓	↓	↓	↓	↓	↓	↓	↓	↓	↓	↓	↓	↓	↓	↓	↓	↓	↓	↓	↓	↓	↓	↓	↓	↓	↓	↓	↓	↓	↓		
5	Over all Y level	↓	↓	↓	↓	↓	↓	↓	↓	↓	↓	↓	↓	↓	↓	↓	↓	↓	↓	↓	↓	↓	↓	↓	↓	↓	↓	↓	↓	↓	↓	↓	↓		
6	FM demodulator linearity	↓	↓	↓	↓	↓	↓	↓	↓	↓	↓	↓	↓	↓	↓	↓	↓	↓	↓	↓	↓	↓	↓	↓	↓	↓	↓	↓	↓	↓	↓	↓	↓	↓	
7	Carrier leakage	↓	↓	↓	↓	↓	↓	↓	↓	↓	↓	↓	↓	↓	↓	↓	↓	↓	↓	↓	↓	↓	↓	↓	↓	↓	↓	↓	↓	↓	↓	↓	↓	↓	
8	PB-YNR characteristics	↓	↓	↓	↓	↓	↓	↓	↓	↓	↓	↓	↓	↓	↓	↓	↓	↓	↓	↓	↓	↓	↓	↓	↓	↓	↓	↓	↓	↓	↓	↓	↓	↓	
9	DOC level	↓	↓	↓	↓	↓	↓	↓	↓	↓	↓	↓	↓	↓	↓	↓	↓	↓	↓	↓	↓	↓	↓	↓	↓	↓	↓	↓	↓	↓	↓	↓	↓	↓	
10	DOC stop level	↓	↓	↓	↓	↓	↓	↓	↓	↓	↓	↓	↓	↓	↓	↓	↓	↓	↓	↓	↓	↓	↓	↓	↓	↓	↓	↓	↓	↓	↓	↓	↓	↓	
11	Nonlinear deemphasis characteristics 1	↓	↓	↓	↓	↓	↓	↓	↓	↓	↓	↓	↓	↓	↓	↓	↓	↓	↓	↓	↓	↓	↓	↓	↓	↓	↓	↓	↓	↓	↓	↓	↓	↓	
12	Nonlinear deemphasis characteristics 2	↓	↓	↓	↓	↓	↓	↓	↓	↓	↓	↓	↓	↓	↓	↓	↓	↓	↓	↓	↓	↓	↓	↓	↓	↓	↓	↓	↓	↓	↓	↓	↓	↓	
13	Double noise canceller characteristics 1	↓	↓	↓	↓	↓	↓	↓	↓	↓	↓	↓	↓	↓	↓	↓	↓	↓	↓	↓	↓	↓	↓	↓	↓	↓	↓	↓	↓	↓	↓	↓	↓	↓	
14	Double noise canceller characteristics 2	↓	↓	↓	↓	↓	↓	↓	↓	↓	↓	↓	↓	↓	↓	↓	↓	↓	↓	↓	↓	↓	↓	↓	↓	↓	↓	↓	↓	↓	↓	↓	↓	↓	
15	Double noise canceller characteristics 3	↓	↓	↓	↓	↓	↓	↓	↓	↓	↓	↓	↓	↓	↓	↓	↓	↓	↓	↓	↓	↓	↓	↓	↓	↓	↓	↓	↓	↓	↓	↓	↓	↓	
16	Picture control "hard" characteristics	↓	↓	↓	↓	↓	↓	↓	↓	↓	↓	↓	↓	↓	↓	↓	↓	↓	↓	↓	↓	↓	↓	↓	↓	↓	↓	↓	↓	↓	↓	↓	↓	↓	
17	Picture control "soft" characteristics	↓	↓	↓	↓	↓	↓	↓	↓	↓	↓	↓	↓	↓	↓	↓	↓	↓	↓	↓	↓	↓	↓	↓	↓	↓	↓	↓	↓	↓	↓	↓	↓	↓	
18	Sync. separator output level	↓	↓	↓	↓	↓	↓	↓	↓	↓	↓	↓	↓	↓	↓	↓	↓	↓	↓	↓	↓	↓	↓	↓	↓	↓	↓	↓	↓	↓	↓	↓	↓	↓	
19	Sync. separator output pulse width	↓	↓	↓	↓	↓	↓	↓	↓	↓	↓	↓	↓	↓	↓	↓	↓	↓	↓	↓	↓	↓	↓	↓	↓	↓	↓	↓	↓	↓	↓	↓	↓	↓	
20	H Sync. Output level	↓	↓	↓	↓	↓	↓	↓	↓	↓	↓	↓	↓	↓	↓	↓	↓	↓	↓	↓	↓	↓	↓	↓	↓	↓	↓	↓	↓	↓	↓	↓	↓	↓	
21	H Sync. Output pulse width	↓	↓	↓	↓	↓	↓	↓	↓	↓	↓	↓	↓	↓	↓	↓	↓	↓	↓	↓	↓	↓	↓	↓	↓	↓	↓	↓	↓	↓	↓	↓	↓	↓	↓
22	Sync. tip level/pedestal level/white level	↓	↓	↓	↓	↓	↓	↓	↓	↓	↓	↓	↓	↓	↓	↓	↓	↓	↓	↓	↓	↓	↓	↓	↓	↓	↓	↓	↓	↓	↓	↓	↓	↓	↓
23	Quasi-V insertion level	↓	↓	↓	↓	↓	↓	↓	↓	↓	↓	↓	↓	↓	↓	↓	↓	↓	↓	↓	↓	↓	↓	↓	↓	↓	↓	↓	↓	↓	↓	↓	↓	↓	↓
24	Quasi-H insertion level	↓	↓	↓	↓	↓	↓	↓	↓	↓	↓	↓	↓	↓	↓	↓	↓	↓	↓	↓	↓	↓	↓	↓	↓	↓	↓	↓	↓	↓	↓	↓	↓	↓	↓
25	White insertion level	↓	↓	↓	↓	↓	↓	↓	↓	↓	↓	↓	↓	↓	↓	↓	↓	↓	↓	↓	↓	↓	↓	↓	↓	↓	↓	↓	↓	↓	↓	↓	↓	↓	↓
26	Edge insertion level	↓	↓	↓	↓	↓	↓	↓	↓	↓	↓	↓	↓	↓	↓	↓	↓	↓	↓	↓	↓	↓	↓	↓	↓	↓	↓	↓	↓	↓	↓	↓	↓	↓	↓
27	4V regulator voltage	↓	↓	↓	↓	↓	↓	↓	↓	↓	↓	↓	↓	↓	↓	↓	↓	↓	↓	↓	↓	↓	↓	↓	↓	↓	↓	↓	↓	↓	↓	↓	↓	↓	↓

REC-C

No.	Parameter	12	17A	19A	19B	20A	21	30A	31A	39A	44	46A	50A	56A	60A	61A	62A	63	64A	66	67	69	71A	74	Gr.1	Gr.2	Gr.3	Gr.4	Gr.5	Gr.6	Gr.7	Gr.8
1	Chroma low freq. conversion output level	↓	↓	↓	↓	↓	↓	↓	↓	↓	↓	↓	↓	↓	↓	↓	↓	↓	↓	↓	↓	↓	↓	↓	↓	0000 1101	0000 1010	0100 0000	↓	↓	↓	↓
2	VXO oscillation level (PAL mode)	↓	↓	↓	↓	↓	↓	↓	↓	↓	↓	↓	↓	↓	↓	↓	↓	↓	↓	↓	↓	↓	↓	↓	↓	0000 1101	0000 1010	0100 0000	↓	↓	↓	↓
3	REC ACC characteristics 1	↓	↓	↓	↓	↓	↓	↓	↓	↓	↓	↓	↓	↓	↓	↓	↓	↓	↓	↓	↓	↓	↓	↓	↓	0000 1101	0000 1010	0100 0000	↓	↓	↓	↓
4	REC ACC characteristics 2	↓	↓	↓	↓	↓	↓	↓	↓	↓	↓	↓	↓	↓	↓	↓	↓	↓	↓	↓	↓	↓	↓	↓	↓	0000 1101	0000 1010	0100 0000	↓	↓	↓	↓
5	REC ACC killer-on input level	↓	↓	↓	↓	↓	↓	↓	↓	↓	↓	↓	↓	↓	↓	↓	↓	↓	↓	↓	↓	↓	↓	↓	↓	0000 1101	0000 1010	0100 0000	↓	↓	↓	↓
6	REC ACC killer-on output level	↓	↓	↓	↓	↓	↓	↓	↓	↓	↓	↓	↓	↓	↓	↓	↓	↓	↓	↓	↓	↓	↓	↓	↓	0000 1101	0000 1010	0100 0000	↓	↓	↓	↓
7	REC ACC killer-on restored input level	↓	↓	↓	↓	↓	↓	↓	↓	↓	↓	↓	↓	↓	↓	↓	↓	↓	↓	↓	↓	↓	↓	↓	↓	0000 1101	0000 1010	0100 0000	↓	↓	↓	↓
8	REC AFC pull-in range 1 (PAL mode)	↓	↓	↓	↓	↓	↓	↓	↓	↓	↓	↓	↓	↓	↓	↓	↓	↓	↓	↓	↓	↓	↓	↓	↓	0000 1101	0000 1010	0100 0000	↓	↓	↓	↓
9	REC AFC pull-in range 2 (PAL mode)	↓	↓	↓	↓	↓	↓	↓	↓	↓	↓	↓	↓	↓	↓	↓	↓	↓	↓	↓	↓	↓	↓	↓	↓	0000 1101	0000 1010	0100 0000	↓	↓	↓	↓
10	REC AFC pull-in range 1	↓	↓	↓	↓	↓	↓	↓	↓	↓	↓	↓	↓	↓	↓	↓	↓	↓	↓	↓	↓	↓	↓	↓	↓	0000 1101	0000 1010	0100 0000	↓	↓	↓	↓
11	REC AFC pull-in range 2	↓	↓	↓	↓	↓	↓	↓	↓	↓	↓	↓	↓	↓	↓	↓	↓	↓	↓	↓	↓	↓	↓	↓	↓	0000 1101	0000 1010	0100 0000	↓	↓	↓	↓
12	Ratio of REC-Y/REC-C 1 (PAL mode)	↓	↓	↓	↓	↓	↓	↓	↓	↓	↓	↓	↓	↓	↓	↓	↓	↓	↓	↓	↓	↓	↓	↓	↓	0000 1101	0000 1010	0100 0000	↓	↓	↓	↓
13	PILOT BURST amplitude	↓	↓	↓	↓	↓	↓	↓	↓	↓	↓	↓	↓	↓	↓	↓	↓	↓	↓	↓	↓	↓	↓	↓	↓	0000 1101	0000 1010	0100 0000	↓	↓	↓	↓
14	PILOT BURST phase	↓	↓	↓	↓	↓	↓	↓	↓	↓	↓	↓	↓	↓	↓	↓	↓	↓	↓	↓	↓	↓	↓	↓	↓	0000 1101	0000 1010	0100 0000	↓	↓	↓	↓
15	SYNC-DET threshold voltage	↓	↓	↓	↓	↓	↓	↓	↓	↓	↓	↓	↓	↓	↓	↓	↓	↓	↓	↓	↓	↓	↓	↓	↓	0000 1101	0000 1010	0100 0000	↓	↓	↓	↓
16	NEW AFC pull-in range 1	↓	↓	↓	↓	↓	↓	↓	↓	↓	↓	↓	↓	↓	↓	↓	↓	↓	↓	↓	↓	↓	↓	↓	↓	0000 1101	0000 1010	0100 0000	↓	↓	↓	↓
17	NEW AFC pull-in range 2	↓	↓	↓	↓	↓	↓	↓	↓	↓	↓	↓	↓	↓	↓	↓	↓	↓	↓	↓	↓	↓	↓	↓	↓	0000 1101	0000 1010	0100 0000	↓	↓	↓	↓
18	OUTPUT LEVEL OF 2FSC	↓	↓	↓	↓	↓	↓	↓	↓	↓	↓	↓	↓	↓	↓	↓	↓	↓	↓	↓	↓	↓	↓	↓	↓	0000 1101	0000 1010	0100 0000	↓	↓	↓	↓
19	HARMONICS OF 2FSC 1	↓	↓	↓	↓	↓	↓	↓	↓	↓	↓	↓	↓	↓	↓	↓	↓	↓	↓	↓	↓	↓	↓	↓	↓	0000 1101	0000 1010	0100 0000	↓	↓	↓	↓
20	HARMONICS OF 2FSC 1	↓	↓	↓	↓	↓	↓	↓	↓	↓	↓	↓	↓	↓	↓	↓	↓	↓	↓	↓	↓	↓	↓	↓	↓	0000 1101	0000 1010	0100 0000	↓	↓	↓	↓

PB-C

No.	Parameter	12	17A	19A	19B	20A	21	30A	31A	39A	44	46A	50A	56A	60A	61A	62A	63	64A	66	67	69	71A	74	Gr.1	Gr.2	Gr.3	Gr.4	Gr.5	Gr.6	Gr.7	Gr.8
1	PB burst video output level (PAL mode)	1	2	2	OFF	2	ON	1	1	OFF	2	2	OFF	2	ON	1	2	1	1	1	1	2	2	2	0010 0101	0000 1101	0000 1010	0100 0000	0110 1000	1000 0000	0011 0100	0011 0000
2	PB burst pin-72 output level	↓	↓	↓	↓	↓	↓	↓	↓	↓	↓	↓	↓	↓	↓	↓	↓	↓	↓	↓	↓	↓	↓	↓	↓	↓	↓	↓	↓	↓	↓	↓
3	PB ACC characteristics 1	↓	↓	↓	↓	↓	↓	↓	↓	↓	↓	↓	↓	↓	↓	↓	↓	↓	↓	↓	↓	↓	↓	↓	↓	↓	↓	↓	↓	↓	↓	↓
4	PB ACC characteristics 2	↓	↓	↓	↓	↓	↓	↓	↓	↓	↓	↓	↓	↓	↓	↓	↓	↓	↓	↓	↓	↓	↓	↓	↓	↓	↓	↓	↓	↓	↓	↓
5	PB ACC killer-on input level	↓	↓	↓	↓	↓	↓	↓	↓	↓	↓	↓	↓	↓	↓	↓	↓	↓	↓	↓	↓	↓	↓	↓	↓	↓	↓	↓	↓	↓	↓	↓
6	PB ACC killer-on chroma output	↓	↓	↓	↓	↓	↓	↓	↓	↓	↓	↓	↓	↓	↓	↓	↓	↓	↓	↓	↓	↓	↓	↓	↓	↓	↓	↓	↓	↓	↓	↓
7	PB main converter carrier leakage	↓	↓	↓	↓	↓	↓	↓	↓	↓	↓	↓	↓	↓	↓	↓	↓	↓	↓	↓	↓	↓	↓	↓	↓	↓	↓	↓	↓	↓	↓	↓
8	PB XO output level (PAL mode)	↓	↓	↓	↓	↓	↓	↓	↓	↓	↓	↓	↓	↓	↓	↓	↓	↓	↓	↓	↓	↓	↓	↓	↓	↓	↓	↓	↓	↓	↓	↓
9	PB XO oscillation frequency deviation	↓	↓	↓	↓	↓	↓	↓	↓	↓	↓	↓	↓	↓	↓	↓	↓	↓	↓	↓	↓	↓	↓	↓	↓	↓	↓	↓	↓	↓	↓	↓
10	NTSC-PAL conversion V-axis burst level	↓	↓	↓	↓	↓	↓	↓	↓	↓	↓	↓	↓	↓	↓	↓	↓	↓	↓	↓	↓	↓	↓	↓	↓	↓	↓	↓	↓	↓	↓	↓
11	NTSC-PAL conversion ratio of burst level	↓	↓	↓	↓	↓	↓	↓	↓	↓	↓	↓	↓	↓	↓	↓	↓	↓	↓	↓	↓	↓	↓	↓	↓	↓	↓	↓	↓	↓	↓	↓
12	PB Chroma 2nd harmonic distortion	↓	↓	↓	↓	↓	↓	↓	↓	↓	↓	↓	↓	↓	↓	↓	↓	↓	↓	↓	↓	↓	↓	↓	↓	↓	↓	↓	↓	↓	↓	↓

REC-EQ

No.	Parameter	12	17A	19A	19B	20A	21	30A	31A	39A	44	46A	50A	56A	60A	61A	62A	63	64A	66	67	69	71A	74	Gr.1	Gr.2	Gr.3	Gr.4	Gr.5	Gr.6	Gr.7	Gr.8
1	REC EQ characteristics 1	↓	↓	↓	↓	↓	↓	↓	↓	↓	↓	↓	↓	↓	↓	↓	↓	↓	↓	↓	↓	↓	↓	↓	↓	↓	↓	↓	↓	↓	↓	↓
2	REC EQ characteristics 2	↓	↓	↓	↓	↓	↓	↓	↓	↓	↓	↓	↓	↓	↓	↓	↓	↓	↓	↓	↓	↓	↓	↓	↓	↓	↓	↓	↓	↓	↓	↓
3	REC EQ 2nd distortion	↓	↓	↓	↓	↓	↓	↓	↓	↓	↓	↓	↓	↓	↓	↓	↓	↓	↓	↓	↓	↓	↓	↓	↓	↓	↓	↓	↓	↓	↓	↓
4	REC EQ characteristics 3	↓	↓	↓	↓	↓	↓	↓	↓	↓	↓	↓	↓	↓	↓	↓	↓	↓	↓	↓	↓	↓	↓	↓	↓	↓	↓	↓	↓	↓	↓	↓

PB-EQ

No.	Parameter	12	17A	19A	19B	20A	21	30A	31A	39A	44	46A	50A	56A	60A	61A	62A	63	64A	66	67	69	71A	74	Gr.1	Gr.2	Gr.3	Gr.4	Gr.5	Gr.6	Gr.7	Gr.8
1	PB EQ characteristics 1	↓	↓	↓	↓	↓	↓	↓	↓	↓	↓	↓	↓	↓	↓	↓	↓	↓	↓	↓	↓	↓	↓	↓	↓	↓	↓	↓	↓	↓	↓	↓
2	PB EQ 2nd distortion	↓	↓	↓	↓	↓	↓	↓	↓	↓	↓	↓	↓	↓	↓	↓	↓	↓	↓	↓	↓	↓	↓	↓	↓	↓	↓	↓	↓	↓	↓	↓
3	PB EQ Low Trap characteristics	↓	↓	↓	↓	↓	↓	↓	↓	↓	↓	↓	↓	↓	↓	↓	↓	↓	↓	↓	↓	↓	↓	↓	↓	↓	↓	↓	↓	↓	↓	↓
4	PB EQ High Trap characteristics	↓	↓	↓	↓	↓	↓	↓	↓	↓	↓	↓	↓	↓	↓	↓	↓	↓	↓	↓	↓	↓	↓	↓	↓	↓	↓	↓	↓	↓	↓	↓

Head Amp MODE TABLE

PB

No.	Parameter	82	82A	83	83A	84	84A	85	85A	88	88A	89	89A	90	90A	91	12	17A	19A	19B	20A	30A	31A	39A	44	46A	50A	55A	60A	61A	62A	63	64A	66	67	71A	74	Gr.1	Gr.2	Gr.3	Gr.4	Gr.5	Gr.6	Gr.7	Gr.8									
1	Current dissipation	OFF	OFF	OFF	OFF	OFF	OFF	ON	ON	OFF	OFF	OFF	OFF	OFF	OFF	ON	1	2	3	ON	2	1	1	OFF	OFF	2	OFF	OFF	ON	1	3	1	2	1	1	2	1	0010 0101	0000 1101	0000 1010	1000 0000	0110 0101	1000 0010	0000 0000	0000 0000									
2	Voltage gain	↓	↓	↓	↓	↓	↓	↓	↓	↓	↓	↓	↓	↓	↓	↓	↓	↓	↓	↓	↓	↓	↓	↓	↓	↓	↓	↓	↓	↓	↓	↓	↓	↓	↓	↓	↓	↓	↓	↓	↓	↓	↓	↓	↓	↓								
3	Input calculation noise voltage	↓	↓	↓	↓	↓	↓	↓	↓	↓	↓	↓	↓	↓	↓	↓	↓	↓	↓	↓	↓	↓	↓	↓	↓	↓	↓	↓	↓	↓	↓	↓	↓	↓	↓	↓	↓	↓	↓	↓	↓	↓	↓	↓	↓	↓	↓	↓						
4	Frequency characteristic	↓	↓	↓	↓	↓	↓	↓	↓	↓	↓	↓	↓	↓	↓	↓	↓	↓	↓	↓	↓	↓	↓	↓	↓	↓	↓	↓	↓	↓	↓	↓	↓	↓	↓	↓	↓	↓	↓	↓	↓	↓	↓	↓	↓	↓	↓	↓	↓					
5	Frequency harmonic distortion	↓	↓	↓	↓	↓	↓	↓	↓	↓	↓	↓	↓	↓	↓	↓	↓	↓	↓	↓	↓	↓	↓	↓	↓	↓	↓	↓	↓	↓	↓	↓	↓	↓	↓	↓	↓	↓	↓	↓	↓	↓	↓	↓	↓	↓	↓	↓	↓	↓				
6	Maximum output level	↓	↓	↓	↓	↓	↓	↓	↓	↓	↓	↓	↓	↓	↓	↓	↓	↓	↓	↓	↓	↓	↓	↓	↓	↓	↓	↓	↓	↓	↓	↓	↓	↓	↓	↓	↓	↓	↓	↓	↓	↓	↓	↓	↓	↓	↓	↓	↓	↓				
7	Cross talk	↓	↓	↓	↓	↓	↓	↓	↓	↓	↓	↓	↓	↓	↓	↓	↓	↓	↓	↓	↓	↓	↓	↓	↓	↓	↓	↓	↓	↓	↓	↓	↓	↓	↓	↓	↓	↓	↓	↓	↓	↓	↓	↓	↓	↓	↓	↓	↓	↓	↓			
8	Output DC off set	↓	↓	↓	↓	↓	↓	↓	↓	↓	↓	↓	↓	↓	↓	↓	↓	↓	↓	↓	↓	↓	↓	↓	↓	↓	↓	↓	↓	↓	↓	↓	↓	↓	↓	↓	↓	↓	↓	↓	↓	↓	↓	↓	↓	↓	↓	↓	↓	↓	↓			
9	Envelope detection output terminal voltage	↓	↓	↓	↓	↓	↓	↓	↓	↓	↓	↓	↓	↓	↓	↓	↓	↓	↓	↓	↓	↓	↓	↓	↓	↓	↓	↓	↓	↓	↓	↓	↓	↓	↓	↓	↓	↓	↓	↓	↓	↓	↓	↓	↓	↓	↓	↓	↓	↓	↓			
10	Envelope detection output terminal voltage SP1	↓	↓	↓	↓	↓	↓	↓	↓	↓	↓	↓	↓	↓	↓	↓	↓	↓	↓	↓	↓	↓	↓	↓	↓	↓	↓	↓	↓	↓	↓	↓	↓	↓	↓	↓	↓	↓	↓	↓	↓	↓	↓	↓	↓	↓	↓	↓	↓	↓	↓	↓		
11	Envelope detection output terminal voltage SP2	↓	↓	↓	↓	↓	↓	↓	↓	↓	↓	↓	↓	↓	↓	↓	↓	↓	↓	↓	↓	↓	↓	↓	↓	↓	↓	↓	↓	↓	↓	↓	↓	↓	↓	↓	↓	↓	↓	↓	↓	↓	↓	↓	↓	↓	↓	↓	↓	↓	↓	↓	↓	
12	Envelope detection output terminal voltage EP1	↓	↓	↓	↓	↓	↓	↓	↓	↓	↓	↓	↓	↓	↓	↓	↓	↓	↓	↓	↓	↓	↓	↓	↓	↓	↓	↓	↓	↓	↓	↓	↓	↓	↓	↓	↓	↓	↓	↓	↓	↓	↓	↓	↓	↓	↓	↓	↓	↓	↓	↓		
12	Envelope detection output terminal voltage EP2	↓	↓	↓	↓	↓	↓	↓	↓	↓	↓	↓	↓	↓	↓	↓	↓	↓	↓	↓	↓	↓	↓	↓	↓	↓	↓	↓	↓	↓	↓	↓	↓	↓	↓	↓	↓	↓	↓	↓	↓	↓	↓	↓	↓	↓	↓	↓	↓	↓	↓	↓	↓	
14	Comparator output voltage 1	↓	↓	↓	↓	↓	↓	↓	↓	↓	↓	↓	↓	↓	↓	↓	↓	↓	↓	↓	↓	↓	↓	↓	↓	↓	↓	↓	↓	↓	↓	↓	↓	↓	↓	↓	↓	↓	↓	↓	↓	↓	↓	↓	↓	↓	↓	↓	↓	↓	↓	↓		
15	Comparator output voltage 2	↓	↓	↓	↓	↓	↓	↓	↓	↓	↓	↓	↓	↓	↓	↓	↓	↓	↓	↓	↓	↓	↓	↓	↓	↓	↓	↓	↓	↓	↓	↓	↓	↓	↓	↓	↓	↓	↓	↓	↓	↓	↓	↓	↓	↓	↓	↓	↓	↓	↓	↓	↓	↓

REC

No.	Parameter	82	82A	83	83A	84	84A	85	85A	88	88A	89	89A	90	90A	91	12	17A	19A	19B	20A	30A	31A	39A	44	46A	50A	55A	60A	61A	62A	63	64A	66	67	71A	74	Gr.1	Gr.2	Gr.3	Gr.4	Gr.5	Gr.6	Gr.7	Gr.8										
1	Current dissipation	OFF	OFF	OFF	OFF	OFF	OFF	ON	ON	OFF	OFF	OFF	OFF	OFF	OFF	ON	1	2	3	ON	2	1	1	OFF	OFF	2	OFF	OFF	ON	1	3	1	2	1	1	2	1	0010 0101	0000 1101	0000 1010	1000 0000	0110 0101	1000 0010	0000 0000	0000 0000										
2	REC AGC Amp output Level	↓	↓	↓	↓	↓	↓	↓	↓	↓	↓	↓	↓	↓	↓	↓	↓	↓	↓	↓	↓	↓	↓	↓	↓	↓	↓	↓	↓	↓	↓	↓	↓	↓	↓	↓	↓	↓	↓	↓	↓	↓	↓	↓	↓	↓	↓	↓	↓	↓	↓	↓			
3	Control characteristics 1	↓	↓	↓	↓	↓	↓	↓	↓	↓	↓	↓	↓	↓	↓	↓	↓	↓	↓	↓	↓	↓	↓	↓	↓	↓	↓	↓	↓	↓	↓	↓	↓	↓	↓	↓	↓	↓	↓	↓	↓	↓	↓	↓	↓	↓	↓	↓	↓	↓	↓	↓	↓		
4	Control characteristics 2	↓	↓	↓	↓	↓	↓	↓	↓	↓	↓	↓	↓	↓	↓	↓	↓	↓	↓	↓	↓	↓	↓	↓	↓	↓	↓	↓	↓	↓	↓	↓	↓	↓	↓	↓	↓	↓	↓	↓	↓	↓	↓	↓	↓	↓	↓	↓	↓	↓	↓	↓	↓		
5	Frequency characteristic	↓	↓	↓	↓	↓	↓	↓	↓	↓	↓	↓	↓	↓	↓	↓	↓	↓	↓	↓	↓	↓	↓	↓	↓	↓	↓	↓	↓	↓	↓	↓	↓	↓	↓	↓	↓	↓	↓	↓	↓	↓	↓	↓	↓	↓	↓	↓	↓	↓	↓	↓	↓		
6	Frequency harmonic distortion	↓	↓	↓	↓	↓	↓	↓	↓	↓	↓	↓	↓	↓	↓	↓	↓	↓	↓	↓	↓	↓	↓	↓	↓	↓	↓	↓	↓	↓	↓	↓	↓	↓	↓	↓	↓	↓	↓	↓	↓	↓	↓	↓	↓	↓	↓	↓	↓	↓	↓	↓	↓	↓	
7	Maximum output level	↓	↓	↓	↓	↓	↓	↓	↓	↓	↓	↓	↓	↓	↓	↓	↓	↓	↓	↓	↓	↓	↓	↓	↓	↓	↓	↓	↓	↓	↓	↓	↓	↓	↓	↓	↓	↓	↓	↓	↓	↓	↓	↓	↓	↓	↓	↓	↓	↓	↓	↓	↓	↓	↓
8	Attenuate volume of mute	↓	↓	↓	↓	↓	↓	↓	↓	↓	↓	↓	↓	↓	↓	↓	↓	↓	↓	↓	↓	↓	↓	↓	↓	↓	↓	↓	↓	↓	↓	↓	↓	↓	↓	↓	↓	↓	↓	↓	↓	↓	↓	↓	↓	↓	↓	↓	↓	↓	↓	↓	↓	↓	
9	Mixed modulation relative level	↓	↓	↓	↓	↓	↓	↓	↓	↓	↓	↓	↓	↓	↓	↓	↓	↓	↓	↓	↓	↓	↓	↓	↓	↓	↓	↓	↓	↓	↓	↓	↓	↓	↓	↓	↓	↓	↓	↓	↓	↓	↓	↓	↓	↓	↓	↓	↓	↓	↓	↓	↓	↓	

REC PAL/SEC

No.	Parameter	12	17A	19A	19B	20A	21	30A	31A	39A	44	46A	50A	56A	60A	61A	62A	63	64A	66	67	69	71A	74	Gr.1	Gr.2	Gr.3	Gr.4	Gr.5	Gr.6	Gr.7	Gr.8
1	Output level of PAL/SEC discriminator	1	1	2	OFF	1	ON	1	1	OFF	OFF	2	OFF	OFF	ON	1	2	1	1	1	1	2	1	2	0010 0000	0000 1101	0000 0010	0100 0100	0110 1000	1000 0101	0011 01**	0011 0000

PB PAL/SEC

No.	Parameter	12	17A	19A	19B	20A	21	30A	31A	39A	44	46A	50A	56A	60A	61A	62A	63	64A	66	67	69	71A	74	Gr.1	Gr.2	Gr.3	Gr.4	Gr.5	Gr.6	Gr.7	Gr.8
1	Input level of R/P discriminator	1	1	2	OFF	1	ON	1	1	OFF	OFF	2	OFF	OFF	ON	1	2	1	1	1	1	2	1	2	0010 0101	0000 1101	0000 0010	0100 0000	0110 1000	1000 0000	0011 0100	0011 0000
2	Burst position of P/S discriminator	↓	↓	↓	↓	↓	↓	↓	↓	↓	↓	↓	↓	↓	↓	↓	↓	↓	↓	↓	↓	↓	↓	↓	↓	↓	↓	↓	↓	↓	↓	↓

REC/PB PAL/SEC

No.	Parameter	12	17A	19A	19B	20A	21	30A	31A	39A	44	46A	50A	56A	60A	61A	62A	63	64A	66	67	69	71A	74	Gr.1	Gr.2	Gr.3	Gr.4	Gr.5	Gr.6	Gr.7	Gr.8
1	Center value of fine adjustment	1	1	2	OFF	1	ON	1	1	OFF	OFF	2	OFF	OFF	ON	1	2	1	1	1	1	2	1	2	0010 0101	0000 1101	0000 0010	0100 0000	0110 1000	1000 0000	0011 0100	0011 0000
2	Threshold voltage of P/S discriminator 1	↓	↓	↓	↓	↓	↓	↓	↓	↓	↓	↓	↓	↓	↓	↓	↓	↓	↓	↓	↓	↓	↓	↓	↓	↓	↓	↓	↓	↓	↓	↓
3	Threshold voltage of P/S discriminator 2	↓	↓	↓	↓	↓	↓	↓	↓	↓	↓	↓	↓	↓	↓	↓	↓	↓	↓	↓	↓	↓	↓	↓	↓	↓	↓	↓	↓	↓	↓	↓

SERIAL Control Table

ADDRESS	8	7	6	5	4	3	2	1		
Group 1							0	0	VIDEO REC	
							0	1	VIDEO PB	
							1	0	VIDEO EE	*
							1	1	VIDEO REC PUASE (BIT TEST ON)	
MODE-1					0	0			REC: V IN-1	*
					0	1			REC: V IN-2	
					1	0			REC: V IN-3	
					1	1			REC: Y/C SEP IN (INJ UP)	
					0			PB: ANR OFF	*	
					1			PB: ANR ON		
				0				PB: Y/C MIX ON	*	
				1				PB: Y/C MIX OFF		
			0	0					AUDIO REC	
			0	1					AUDIO PB	
			1	0					AUDIO EE	*
			1	1					PROHIBIT (Y-TEST MODE)	
	0	0							A IN-1	*
	0	1							A IN-2	
	1	0							A IN-3	
	1	1							PROHIBIT (INJ DOWN SELECT)	

ADDRESS	8	7	6	5	4	3	2	1		
Group 2							0	0	NTSC/M	
							0	1	PAL-GBI,N/EM	*
							1	0	PAL-M/M	
							1	1	SECAM/MESECAM/EM *1	
SYSTEM						0			Y-3.58MHz	
						1			Y-4.43MHz	*
					0				C-3.58MHz	
					1				C-4.43MHz	*
			0	0					AUTO KILLER	*
			0	1					FORCED COLOR/MESECAM SELECT *1	
			1	0					FORCED KILLER/SECAM SELECT *1	
			1	1					PROHIBIT (INJ U/D & T-TEST SELECT)	
		0							NORMAL MODE	*
		1							BLUE BACK MODE (T-TEST)	
		0							REC: Pilot burst 270 DEG/PB: ENV DET SENS = HIGH	*
		1							REC: Pilot burst 90 DEG/PB: ENV DET SENS = LOW	

CAUTION; Gr3 bit-4, 3
 LA71578HM bit-4=0, bit-3=(no-care)
 LA71598HM bit-4=1, bit-3= can select as table



ADDRESS	8	7	6	5	4	3	2	1		
								0	NORMAL VXO	*
								1	FORCED XO	
Group 3							0		DOC OFF/REC-EQ: STEEP	
							1		DOC AUTO/REC-EQ: STEEPNESS	*
MODE-2					0				NON-CORRE OUT MODE; LA71586M ONLY ← CAUTION	*
					1				CHOROMA DET OUT MODE; LA71586M ONLY ← CAUTION	
				0					LA71584M MODE ← CAUTION	*
				1					LA71586M MODE ← CAUTION	
			0	0					SP (VIDEO) & CARRIER SHIFT OFF	*
			0	1					LP (VIDEO)	
			1	0					EP (VIDEO)	
			1	1					SP (VIDEO) & CARRIER SHIFT ON	
	0	0							SP (AUDIO)	*
	0	1							LP (AUDIO)	
	1	0							EP (AUDIO)	
	1	1							PROHIBIT (F-TEST MODE)	

ADDRESS	8	7	6	5	4	3	2	1		
Group 4							0	0	YNR/LNC OFF *2	*
							0	1	YNR/LNC STANDARD *2	
							1	0	YNR/LNC MIDIUUM *2	
							1	1	YNR/LNC STRONG *2	
						0			YNR MODE	*
						1			LNC MODE	
NR			0	0	0				NC1 CTL/DETAIL CTL-1 LIM = MIN	*
			0	0	1				NC1 CTL/DETAIL CTL-2	
			0	1	0				NC1 CTL/DETAIL CTL-3	
			0	1	1				NC1 CTL/DETAIL CTL-4	
			1	0	0				NC1 CTL/DETAIL CTL-5	
			1	0	1				NC1 CTL/DETAIL CTL-6	
			1	1	0				NC1 CTL/DETAIL CTL-7	
			1	1	1				NC1 CTL/DETAIL CTL-8 LIM = MAX	
		0	0						Y DELAY -80N	
		0	1						Y DELAY 0N	*
	1	0						Y DELAY 80N		
	1	1						Y DELAY 160N		

LA71598HM

ADDRESS	8	7	6	5	4	3	2	1		
Group 5 EQ							0	0	PB EQ F0. 6.0M	
							0	1	PB EQ F0. 5.5M	*
							1	0	PB EQ F0. 5.0M	
							1	1	PB EQ F0. 4.5M	
					0	0			R/P EQ TRAP: 500k+650k	
					0	1			R/P EQ TRAP: 500k+800k	*
					1	0			R/P EQ TRAP: 500k+1.1M	
					1	1			R/P EQ TRAP: 500k	
			0	0					PB EQ PEAK-Narrow/REC EQ SLOPE-GENTLE	
			0	1					PB EQ PEAK-2/REC EQ SLOPE-2	
			1	0					PB EQ PEAK-3/REC EQ SLOPE-3	*
			1	1					PB EQ PEAK-Wide/REC EQ SLOPE-STEEP	
		0	0						PB EQ H-TRAP 10MHz/REC EQ H-TRAP 10MHz	
		0	1						PB EQ H-TRAP 9MHz/REC EQ H-TRAP 9MHz	*
	1	0						PB EQ H-TRAP 8MHz/REC EQ H-TRAP 8MHz		
	1	1						PB EQ H-TRAP 7MHz/REC EQ H-TRAP 7MHz		

ADDRESS	8	7	6	5	4	3	2	1		
Group 6 at PB MODE								0	CHILD LOCK OFF	*
								1	CHILD LOCK ON	
								0	PHASE ALTERNATOR ON; PAL ONLY	*
								1	PHASE ALTERNATOR OFF; PAL ONLY	
						0			NORMAL PB	
						1			TRICK PB	*
					0				APC LOOP BEFORE	*
					1				APC LOOP AFTER	
				0						*
				1						
		0	0	0						PIC CTL -6dB / soft
		0	0	1						PIC CTL -4dB
		0	1	0						PIC CTL -2dB
		0	1	1						PIC CTL 0dB
		1	0	0						PIC CTL 0dB
		1	0	1						PIC CTL +2dB
		1	1	0						PIC CTL +4dB
		1	1	1						PIC CTL +6dB/sharp

LA71598HM

ADDRESS	8	7	6	5	4	3	2	1		
Group 6 at REC MODE							0	0	REC FM LEVEL -0.9dB	*
							0	1	REC FM LEVEL -0dB	
							1	0	REC FM LEVEL +0.9dB	
							1	1	REC FM LEVEL +1.8dB	
						0			WC 195%	
						1			WC 185%	*
					0				NORMAL MODE	*
					1				SYNC CARRIER OUT MODE	
	0	0	0	0					REC CURRENT-1/MIN	
	0	0	0	1					REC CURRENT-2	
	0	0	1	0					REC CURRENT-3	
	0	0	1	1					REC CURRENT-4	
	0	1	0	0					REC CURRENT-5	
	0	1	0	1					REC CURRENT-6	
	0	1	1	0					REC CURRENT-7	
	0	1	1	1					REC CURRENT-8	
	1	0	0	0					REC CURRENT-9/TYP	*
	1	0	0	1					REC CURRENT-10	
	1	0	1	0					REC CURRENT-11	
	1	0	1	1					REC CURRENT-12	
1	1	0	0					REC CURRENT-13		
1	1	0	1					REC CURRENT-14		
1	1	1	0					REC CURRENT-15		
1	1	1	1					REC CURRENT-16/MAX		

ADDRESS	8	7	6	5	4	3	2	1		
Group 7							0	0	REC C LEVEL 0dB/PB NORMAL	*
							0	1	REC C LEVEL -1.5dB/PB NAP	
							1	0	REC C LEVEL -3.0dB/PB BALA-MOD	
							1	1	REC C LEVEL -4.5dB/PB PROHIBIT (NO-OPERATION)	
						0			CG NORMAL/PB BST DE-EM -5.0dB	*
						1			CG STOP/PB BST DE-EM -5.5dB	
					0				NORMAL	*
LEVEL CTL					1				PROHIBIT (T-TEST)	
				0					BGP=INTERVAL	*
				1					BGP=CONTINUE	
			0						SYNC SLICE LEVEL=SYNC TIP SIDE	*
			1						SYNC SLICE LEVEL=PEDESTAL SIDE	
	0	0							NL OFF	*
	0	1							NL STRONG	
	1	0							NL MIDIUM	
1	1							NL STANDARD		

ADDRESS	8	7	6	5	4	3	2	1		
Group 8				0	0	0	0	0	PB:AUDIO LEVEL-1/LOW	*
				0	0	0	0	1	PB:AUDIO LEVEL-2	
				0	0	0	1	0	PB:AUDIO LEVEL-3	
				0	0	0	1	1	PB:AUDIO LEVEL-4	
				0	0	1	0	0	PB:AUDIO LEVEL-5	
				0	0	1	0	1	PB:AUDIO LEVEL-6	
				0	0	1	1	0	PB:AUDIO LEVEL-7	
OTHERS				0	0	1	1	1	PB:AUDIO LEVEL-8	
				0	1	0	0	0	PB:AUDIO LEVEL-9	
				0	1	0	0	1	PB:AUDIO LEVEL-10	
				0	1	0	1	0	PB:AUDIO LEVEL-11	
				0	1	0	1	1	PB:AUDIO LEVEL-12	
				0	1	1	0	0	PB:AUDIO LEVEL-13	
				0	1	1	0	1	PB:AUDIO LEVEL-14	
				0	1	1	1	0	PB:AUDIO LEVEL-15	
				0	1	1	1	1	PB:AUDIO LEVEL-16	
				1	0	0	0	0	PB:AUDIO LEVEL-17	
				1	0	0	0	1	PB:AUDIO LEVEL-18	
				1	0	0	1	0	PB:AUDIO LEVEL-19	
				1	0	0	1	1	PB:AUDIO LEVEL-20	
				1	0	1	0	0	PB:AUDIO LEVEL-21	
				1	0	1	0	1	PB:AUDIO LEVEL-22	
				1	0	1	1	0	PB:AUDIO LEVEL-23	
				1	0	1	1	1	PB:AUDIO LEVEL-24	
				1	1	0	0	0	PB:AUDIO LEVEL-25	
				1	1	0	0	1	PB:AUDIO LEVEL-26	
				1	1	0	1	0	PB:AUDIO LEVEL-27	
				1	1	0	1	1	PB:AUDIO LEVEL-28	
				1	1	1	0	0	PB:AUDIO LEVEL-29	
				1	1	1	0	1	PB:AUDIO LEVEL-30	
				1	1	1	1	0	PB:AUDIO LEVEL-31	
				1	1	1	1	1	PB:AUDIO LEVEL-32/HIGH	
		0							AUDIO AUTO BIAS	*
		1							AUDIO BIAS ADJ MODE	
	0								INTERNAL EQ	*
	1								EXTERMAL EQ	
	1								SVHS	

Contents ;

- (*) mark shows initial condition.
- PROHIBIT, () mark shows test mode control. Cannot use their bits, except test mode.
- SLAVE ADDRESS is [1110 001].
- SDA OUT DATA (BIT-8 TO BIT-2): PAL/MESEC DET OUT, SYNC DET OUT, PAL-M DET OUT, KILLER OUT, V-LATCH RESULT (for Group-6), V-LATCH RESULT (for Group-5), ACC-KIL OUT
- This LSI is controlled by auto address increment mode.
- This LSI has V-latch system. (controlled by RF-SW pulse)
V-latch items: Gr5 and Gr6 (all bits)
- * 1 BIT 6, 5, 2, 1= 0, 1, 1, 1 (MESECAM MODE: system change as following)
→ KIL/ID DET STOP & ACK OUT = [L] FIX & FORCED COLOR MODE & FORCED XO & AFC MODE
- * 1 BIT 6, 5, 2, 1= 1, 0, 1, 1 (SECAM MODE: system change as following)

LA71598HM

→ KIL DET ACTIVE & LOW CHROMA STOP

* 2 On REC-LNC mode, we recommend LNC-OFF or LNC STANDARD mode.

Sample Application

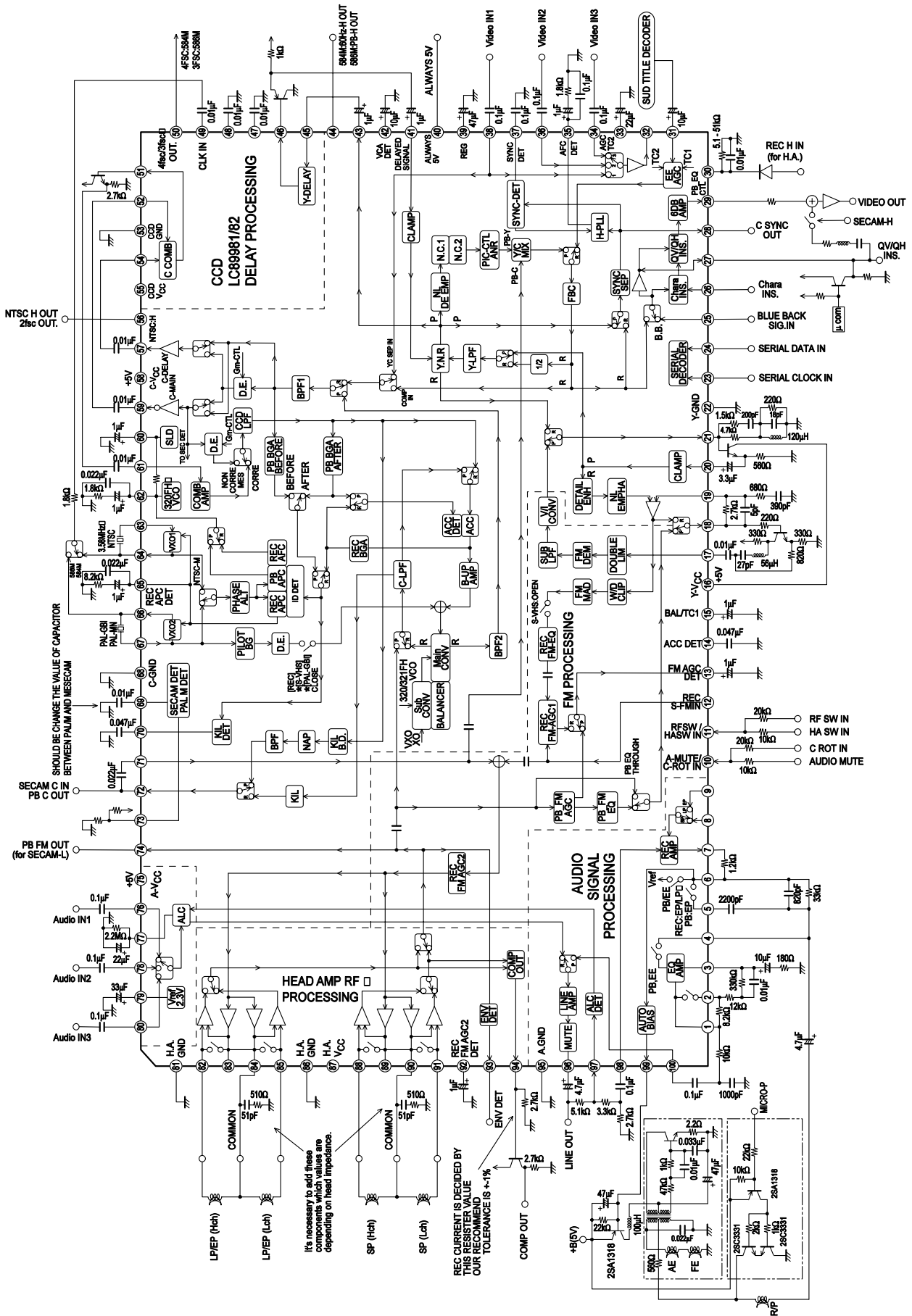

- Specifications of any and all SANYO Semiconductor products described or contained herein stipulate the performance, characteristics, and functions of the described products in the independent state, and are not guarantees of the performance, characteristics, and functions of the described products as mounted in the customer's products or equipment. To verify symptoms and states that cannot be evaluated in an independent device, the customer should always evaluate and test devices mounted in the customer's products or equipment.
- SANYO Semiconductor Co., Ltd. strives to supply high-quality high-reliability products. However, any and all semiconductor products fail with some probability. It is possible that these probabilistic failures could give rise to accidents or events that could endanger human lives, that could give rise to smoke or fire, or that could cause damage to other property. When designing equipment, adopt safety measures so that these kinds of accidents or events cannot occur. Such measures include but are not limited to protective circuits and error prevention circuits for safe design, redundant design, and structural design.
- In the event that any or all SANYO Semiconductor products (including technical data, services) described or contained herein are controlled under any of applicable local export control laws and regulations, such products must not be exported without obtaining the export license from the authorities concerned in accordance with the above law.
- No part of this publication may be reproduced or transmitted in any form or by any means, electronic or mechanical, including photocopying and recording, or any information storage or retrieval system, or otherwise, without the prior written permission of SANYO Semiconductor Co., Ltd.
- Any and all information described or contained herein are subject to change without notice due to product/technology improvement, etc. When designing equipment, refer to the "Delivery Specification" for the SANYO Semiconductor product that you intend to use.
- Information (including circuit diagrams and circuit parameters) herein is for example only; it is not guaranteed for volume production. SANYO Semiconductor believes information herein is accurate and reliable, but no guarantees are made or implied regarding its use or any infringements of intellectual property rights or other rights of third parties.

This catalog provides information as of December, 2006. Specifications and information herein are subject to change without notice.