



SANYO Semiconductors

# DATA SHEET

## LA73033M — Monolithic Linear IC I<sup>2</sup>C bus control (excluding standby control and RGB through control)

### Overview

This LA73033M is DVD recorder video signal input SW & output driver.

### Functions

[SW side]

- Composite signal five-input SW and S signal three-input SW
- Keyed clamp
- Component signal or RGB signal 1 input
- 0dB/ 6dB amplifier
- AGC amplifier (composite and Y signal only)
- LPF for removal of 13.5MHz clock
- Composite output/ Y output changeover switch
- Compatible with standby (two types)
- C.SYNC & V.SYNC output

[Driver side]

- Six-channel input & six-channel output of composite signal & S signal & component or RGB signal
- Clamp (keyed clamp for Cb and Cr)
- 6dB/ 9dB amplifier amplifier
- LPF for removal of 27MHz/ 54MHz clock
- Output mute (three types)
- 75Ω driver (two drives possible)
- Through changeover of RGB signal from the SW side
- Y/ C-MIX
- DC output for S1/ S2
- SCART-RGB/ YC changeover SW

■ Any and all SANYO Semiconductor Co.,Ltd. products described or contained herein are, with regard to "standard application", intended for the use as general electronics equipment (home appliances, AV equipment, communication device, office equipment, industrial equipment etc.). The products mentioned herein shall not be intended for use for any "special application" (medical equipment whose purpose is to sustain life, aerospace instrument, nuclear control device, burning appliances, transportation machine, traffic signal system, safety equipment etc.) that shall require extremely high level of reliability and can directly threaten human lives in case of failure or malfunction of the product or may cause harm to human bodies, nor shall they grant any guarantee thereof. If you should intend to use our products for applications outside the standard applications of our customer who is considering such use and/or outside the scope of our intended standard applications, please consult with us prior to the intended use. If there is no consultation or inquiry before the intended use, our customer shall be solely responsible for the use.

■ Specifications of any and all SANYO Semiconductor Co.,Ltd. products described or contained herein stipulate the performance, characteristics, and functions of the described products in the independent state, and are not guarantees of the performance, characteristics, and functions of the described products as mounted in the customer's products or equipment. To verify symptoms and states that cannot be evaluated in an independent device, the customer should always evaluate and test devices mounted in the customer's products or equipment.

**SANYO Semiconductor Co., Ltd.**

TOKYO OFFICE Tokyo Bldg., 1-10, 1 Chome, Ueno, Taito-ku, TOKYO, 110-8534 JAPAN

**Specifications**

**Maximum Ratings** at Ta = 25°C

Parameter	Symbol	Conditions	Ratings	Unit
Maximum supply voltage	V <sub>CC</sub> max		7.0	V
Allowable power dissipation	Pd max	Ta ≤ 75°C * Mounted on a board	1200	mW
Operating temperature	T <sub>opg</sub>		-20 to +75	°C
Storage temperature	T <sub>stg</sub>		-40 to +150	°C

\* Mounted on a board : 114.3×76.1×1.6mm<sup>3</sup>, glass epoxy board.

**Recommended Operating Conditions** at Ta = 25°C

Parameter	Symbol	Conditions	Ratings	Unit
Recommended supply voltage	V <sub>CC</sub>		5.0	V
Operating supply voltage range	V <sub>CC</sub> opg		4.75 to 5.25	V
Input pin voltage application range	V <sub>IN</sub>	V <sub>CC</sub> opg +0.3 ≤ 7V	-0.3 to V <sub>CC</sub> opg +0.3	V

**Package Dimensions**

unit : mm (typ)

3255

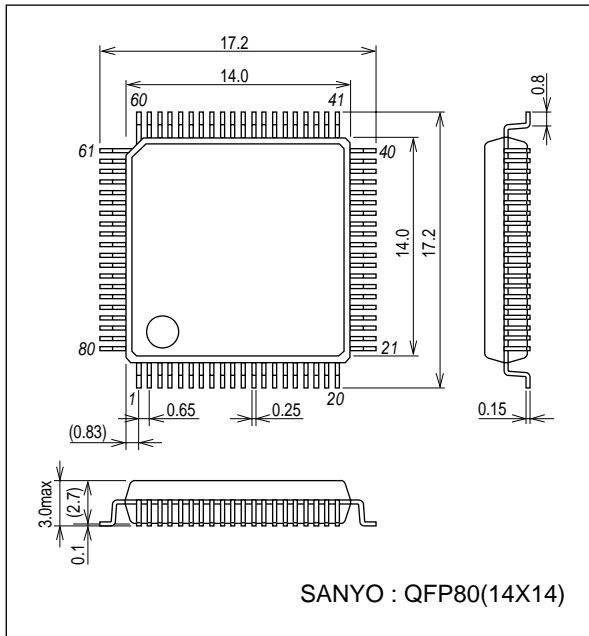

Electrical Characteristics at Ta = 25°C, VCC = 5.0V

Parameter	Symbol	Input signal			Out Point	Test Condition	Spec			unit	R1	Control voltage			I <sup>2</sup> C bus data (MSB-LSB)	
		Point	Signal	Freq			Mag	min	typ			max	V18	V38	V30, V35	SW1
Current drain 1	I <sub>CC11</sub>					Current flowing through V <sub>CC1</sub> at no signal	58	73	88	mA	330	0	0	3.5	01000010	00000000
Current drain at standby	I <sub>CC12</sub>					Current flowing through V <sub>CC1</sub> at standby control	9	11	13	mA	330	3	0			
Current drain 1 at RGB standby	I <sub>CC13</sub>					Current flowing through V <sub>CC1</sub> at EXT-RGB control	11	14	17	mA	330	3	3			
Composite output clamp voltage	C23	V <sub>IN13</sub>	SG3		1Vp-p	Measure the output clamp voltage (sink chip voltage)	0.7	0.8	0.9	V	330	0	0	3.5	01001010	00000000
		V <sub>IN15</sub>					01101010	00000000								
		V <sub>IN17</sub>					10001010	00000000								
		V <sub>IN19</sub>					10101010	00000000								
		V <sub>IN21</sub>					11001010	00000000								
Chroma output center voltage	C25	V <sub>IN7</sub>	SG2		714mVp-p	Measure the output DC voltage (center voltage)	2.2	2.4	2.7	V	330	0	0	3.5	01000100	00000000
		V <sub>IN5</sub>					01100100	00000000								
		V <sub>IN3</sub>					10000100	00000000								
Y output clamp voltage	C27	V <sub>IN79</sub>	SG1		1Vp-p	Measure the output clamp voltage (sink chip voltage)	0.7	0.8	0.9	V	330	0	0	3.5	01000100	00000000
		V <sub>IN77</sub>					01100100	00000000								
		V <sub>IN75</sub>					10000100	00000000								
Component output pedestal voltage	PC23 PC25	V <sub>IN1</sub>	SG5		1Vp-p	Measure the output pedestal clamp voltage	2.4	2.5	2.6	V	330	0	0	3.5	00000100	00000000
		V <sub>IN11</sub>	SG6		1Vp-p		T23									
		V <sub>IN9</sub>	SG6		1Vp-p		T25									
		V <sub>IN73</sub>	SG8		700mVp-p		T23									
RGB output clamp voltage	RC23 RC25	V <sub>IN11</sub>	SG8		700mVp-p	Measure the output pedestal clamp voltage	1.15	1.25	1.35	V	330	0	0	3.5	00100100	00000000
		V <sub>IN9</sub>	SG8		700mVp-p		T25									
		V <sub>IN1</sub>	SG5		1Vp-p		T25									
		V <sub>IN73</sub>	SG8		700mVp-p		T29									
Gain at 6dB	G23H G25H G27H	V <sub>IN13</sub>	SG5		1Vp-p	Measure GAIN for input of each output	5.5	6	6.5	dB	330	0	0	3.5	01001010	00000000
		V <sub>IN7</sub>	SG6		714mVp-p		T25									
		V <sub>IN79</sub>	SG5		1Vp-p		T27									
		V <sub>IN11</sub>	SG8		700mVp-p		T23									
	G25H G27H G29H	V <sub>IN9</sub>	SG8		700mVp-p							0	0	3.5	01000100	00000000
		V <sub>IN1</sub>	SG5		1Vp-p		T27									
		V <sub>IN73</sub>	SG8		700mVp-p		T29									

Continued on next page

Parameter	Symbol	Input signal			Mag	Out Point	Test Condition	Spec			unit	R1	Control voltage			I <sup>2</sup> C bus data (MSB-LSB)		
		Point	Signal	Freq				min	typ	max			V18	V38	V30, V35	SW1	SW2	
Gain at 0dB	G23L	V <sub>IN13</sub>	SG5		2Vp-p	T27	Measure GAIN for input of each output	0	0	0.5	dB	330	0	0	0	01000010	00000000	
	G25L	V <sub>IN7</sub>	SG6		1.428Vp-p	T25		-0.5									01000000	00000000
	G27L	V <sub>IN79</sub>	SG5		2Vp-p	T27											01000000	00000000
AGC-AMP control voltage	G23H	V <sub>IN11</sub>	SG8		1.4Vp-p	T23	Measure V30 and V35 where the output gain changeable.	2	3.5	5	V	330	0	0	0	01001010	10000000	
	G25H	V <sub>IN9</sub>	SG8		1.4Vp-p	T25											01001000	10000000
	G27H	V <sub>IN1</sub>	SG5		2Vp-p	T27											01001010	00000000
	G29H	V <sub>IN73</sub>	SG8		1.4Vp-p	T29											01000100	00000000
10MHz change rate of f characteristics of gain	VA23M	V <sub>IN13</sub>	SG5		1Vp-p	T27	Measure gain for input of each output and calculates the change rate for gain at 100kHz.	-0.5	-0.1	0.5	dB	330	0	0	0	01001010	00000000	
	VA27M	V <sub>IN79</sub>	SG5		1Vp-p	T27											01001000	10000000
	F23	V <sub>IN13</sub>	SG3	10MHz	1Vp-p	T27											01001010	00000000
	F25	V <sub>IN7</sub>	SG2	10MHz	714mVp-p	T25											01000100	00000000
	F27	V <sub>IN79</sub>	SG1	10MHz	1Vp-p	T27											01001000	00000000
4.5MHz change rate of f characteristics of gain (with LPF)	F23	V <sub>IN11</sub>	SG9	10MHz	700mVp-p	T23	Measure gain for input of each output and calculates the change rate for gain at 100kHz.	-0.5	-0.2	0.5	dB	1k	0	0	0	01011010	00000000	
	F25	V <sub>IN9</sub>	SG9	10MHz	700mVp-p	T25											01010100	00000000
	F27	V <sub>IN1</sub>	SG1	10MHz	1Vp-p	T27											01011000	00000000
	F29	V <sub>IN73</sub>	SG9	10MHz	700mVp-p	T29											00101100	00000000
	F23L1	V <sub>IN13</sub>	SG3	4.5MHz	1Vp-p	T27											01011010	00000000
5MHz change rate of f characteristics of gain (with LPF)	F25L1	V <sub>IN7</sub>	SG2	4.5MHz	714mVp-p	T25	Measure gain for input of each output and calculates the change rate for gain at 100kHz.	-1	-0.3	0.5	dB	1k	0	0	0	01011010	00000000	
	F27L1	V <sub>IN79</sub>	SG1	4.5MHz	1Vp-p	T27											01010100	00000000
	F23L1	V <sub>IN11</sub>	SG9	4.5MHz	700mVp-p	T23											01011000	00000000
	F25L1	V <sub>IN9</sub>	SG9	4.5MHz	700mVp-p	T25											00111100	00000000
	F27L1	V <sub>IN1</sub>	SG1	4.5MHz	1Vp-p	T27											01011010	00000000
5MHz change rate of f characteristics of gain (with LPF)	F29L1	V <sub>IN73</sub>	SG9	4.5MHz	700mVp-p	T29	Measure gain for input of each output and calculates the change rate for gain at 100kHz.	-1	-0.3	0.5	dB	1k	0	0	0	01011010	00000000	
	F23L2	V <sub>IN13</sub>	SG3	5MHz	1Vp-p	T27											01010100	00000000
	F25L2	V <sub>IN7</sub>	SG2	5MHz	714mVp-p	T25											01010100	00000000
	F27L2	V <sub>IN79</sub>	SG1	5MHz	1Vp-p	T27											01011000	00000000
	F23L2	V <sub>IN11</sub>	SG9	5MHz	700mVp-p	T23											00111100	00000000
F25L2	V <sub>IN9</sub>	SG9	5MHz	700mVp-p	T25									00111100	00000000			
F27L2	V <sub>IN1</sub>	SG1	5MHz	1Vp-p	T27									00111100	00000000			
F29L2	V <sub>IN73</sub>	SG9	5MHz	700mVp-p	T29									00111100	00000000			

Continued on next page

Parameter	Symbol	Input signal			Out		Test Condition	Spec			unit	R1	Control voltage			I <sup>2</sup> C bus data (MSB-LSB)	
		Point	Signal	Freq	Mag	Point		min	typ	max			V18	V38	V30, V35	SW1	SW2
13.5 MHz change rate of f characteristics of gain (with LPF)	F23L3	V <sub>IN13</sub>	SG3	13.5MHz	1Vp-p	T27	Measure gain for input of each output and calculates the change rate for gain at 100kHz.		-41	-30	dB	1k	0	0	3.5	01011010	00000000
	F25L3	V <sub>IN7</sub>	SG2	13.5MHz	714mVp-p	T25										01010100	00000000
	F27L3	V <sub>IN79</sub>	SG1	13.5MHz	1Vp-p	T27										01011000	00000000
		V <sub>IN11</sub>	SG9	13.5MHz	700mVp-p	T23										00111100	00000000
Output drive capacity 1 (secondary distortion)	H23	V <sub>IN13</sub>	SG3	5MHz	1Vp-p	T27	Connect the load of 330Ω to the output via C connection and measure the secondary distortion of output.		-45	-35	dB	330	0	0	3.5	01001010	00000000
	H25	V <sub>IN7</sub>	SG2	5MHz	714mVp-p	T25										01000100	00000000
	H27	V <sub>IN79</sub>	SG1	5MHz	1Vp-p	T27										01001000	00000000
		V <sub>IN11</sub>	SG9	5MHz	700mVp-p	T23										00101100	00000000
Output drive capacity 1 (secondary distortion) (with LPF)	H23	V <sub>IN13</sub>	SG3	5MHz	1Vp-p	T27	Connect the load of 1kΩ to the output via C connection and measure the secondary distortion of output.		-45	-35	dB	330	0	0	3.5	01011010	00000000
	H25	V <sub>IN7</sub>	SG2	5MHz	714mVp-p	T25										01010100	00000000
	H27	V <sub>IN79</sub>	SG1	5MHz	1Vp-p	T27										01011000	00000000
		V <sub>IN11</sub>	SG9	5MHz	700mVp-p	T23										00111100	00000000
C.SYNC output H voltage	V36H	V <sub>IN13</sub>	SG5		1Vp-p	T36	Connect 10kΩ between this output and V <sub>CC</sub> .	4.75	5	5.25	V	0	0	0	3.5	01001010	00000000
		V <sub>IN79</sub>	SG5		1Vp-p	T36										01001000	00000000
C.SYNC output L voltage	V36L	V <sub>IN13</sub>	SG5		1Vp-p	T36	Connect 10kΩ between this output and V <sub>CC</sub> .	0	0.3	0.6	V		0	0	3.5	01001010	00000000
		V <sub>IN79</sub>	SG5		1Vp-p	T36										01001000	00000000
C.SYNC2 output H voltage	V37H	V <sub>IN13</sub>	SG5		1Vp-p	T37	Connect 10kΩ between this output and V <sub>CC</sub> .	4.75	5	5.25	V		0	0	3.5	01001010	00000000
		V <sub>IN79</sub>	SG5		1Vp-p	T37										01001000	00000000
C.SYNC2 output L voltage	V37L	V <sub>IN13</sub>	SG5		1Vp-p	T37	Connect 10kΩ between this output and V <sub>CC</sub> .	0	0.3	0.6	V		0	0	3.5	01001010	00000000
		V <sub>IN79</sub>	SG5		1Vp-p	T37										01001000	00000000

Continued on next page.

Continued from preceding page.

Parameter	Symbol	Input signal			Out Point	Test Condition	Spec			Control voltage			I <sup>2</sup> C bus data (MSB-LSB)		
		Point	Signal	Freq			Mag	min	typ	max	unit	R1	V18	V38	V30, V35
C.SYNC output pulse width	W36	V <sub>IN13</sub> V <sub>IN79</sub>	SG5 SG5		1Vp-p 1Vp-p	Output pulse width	3.2	4.2	5.2	μs	0	0	3.5	01001010 01001000	00000000 00000000
C.SYNC threshold level	W36V	V <sub>IN13</sub> V <sub>IN79</sub>	SG5 SG5		1Vp-p 1Vp-p	The value of input SYNC at which the output pulse width becomes 1.3-folds or more as the input SYNC is reduced.	7.5	11.5	15.5	IRE	0	0	3.5	01001010 01001000	00000000 00000000

(Note) The C. SYNC2 threshold level is 12 IRE at 6dB and 12.8 IRE at 0dB .

**Design guarantee items**

Parameter	Symbol	Input signal				Out Point	Test Condition	Spec			Control voltage			I <sup>2</sup> C bus data (MSB-LSB)			
		Point	Signal	Freq	Mag			min	typ	max	unit	R1	V18	V38	V30, V35	SW1	SW2
DG	DG23	V <sub>IN13</sub>	SG7	3.58MHz	1Vp-p	T27	Ratio of the amplitude on the white level relative to that on the black level.	-2	1	2	%	0	0	3.5	01011010	00000000	
	DG27	V <sub>IN79</sub>	SG7	3.58MHz	1Vp-p	T27									01011000	00000000	
	ADG23	V <sub>IN13</sub>	SG7	3.58MHz	1Vp-p	T27	When AGC amplifier is used	-2	1	2	%			VA23M	01011010	10000000	
	ADG27	V <sub>IN79</sub>	SG7	3.58MHz	1Vp-p	T27								VA27M	01011000	10000000	
DP	DP23	V <sub>IN13</sub>	SG7	3.58MHz	1Vp-p	T27	Difference of the phase on the white level relative to that on the black level	-1	1	1.5	deg	0	0	3.5	01011010	00000000	
	DP27	V <sub>IN79</sub>	SG7	3.58MHz	1Vp-p	T27									01011000	00000000	
Crosstalk	ADP23	V <sub>IN13</sub>	SG7	3.58MHz	1Vp-p	T27	When AGC amplifier is used	-1	1.2	2	deg			VA23M	01011010	10000000	
	ADP27	V <sub>IN79</sub>	SG7	3.58MHz	1Vp-p	T27								VA27M	01011000	10000000	
	CT23	V <sub>IN13</sub> V <sub>IN15</sub>	SG5 SG5		1Vp-p 1Vp-p	T27	The magnitude of crosstalk in which the non-selected input signal is carried on the selected signal output is specified by the value of selected signal output.		-60	-55	dB	330	0	0	3.5	01001010	00000000
	CT25	V <sub>IN7</sub> V <sub>IN5</sub>	SG2 SG2	4MHz 4MHz	714mVp-p 714mVp-p	T25				-60	-55	dB	330	0	0	3.5	01000100
CT27	V <sub>IN79</sub> V <sub>IN77</sub>	SG5 SG5		1Vp-p 1Vp-p	T27			-60	-55	dB	330	0	0	3.5	01001000	00000000	
Video S/N ratio	SN23	V <sub>IN13</sub>	SG5		1Vp-p	T27	S/N in the HPF100kHz and LPF 10MHz bands is expressed in dB.		-70	-65	dB	330	0	0	3.5	01001010	00000000
	SN27	V <sub>IN79</sub>	SG5		1Vp-p	T27										01001000	00000000
Video S/N ratio (with LPF)	SN23	V <sub>IN13</sub>	SG5		1Vp-p	T27	S/N in the HPF100kHz and LPF 10MHz bands is expressed in dB.		-65	-60	dB	1k	0	0	3.5	01011010	00000000
	SN27	V <sub>IN79</sub>	SG5		1Vp-p	T27										01011000	00000000

**Electrical characteristics** at Ta=25°C, unless otherwise specified VCC = 5.0V

Parameter	Symbol	Input signal			Out Point	Test Condition	Spec			unit	Control voltage		SW		I <sup>2</sup> C bus data (MSB-LSB)	
		Point	Signal	Freq			Mag	min	typ		max	V18	V38	S68, S65, S63	S60, S58, S56	DV1
Current drain 2	ICC21				VCC2	Current flowing through VCC2 at no signal	64	80	96	mA	0	0	ON	ON	00000000	00110000
Current drain at RGB standby 2	ICC23				VCC2	Current flowing through VCC2 at EXT-RGB control	18	22	26	mA	3	3	ON	ON		
Gain at 6dB for two drives	G68L	VIN39	SG3			Measure gain of each output relative to input	5.6	5.9	6.4	dB	0	0	ON	ON	00000000	00110000
	G65L	VIN41	SG2				T68									
	G63L	VIN43	SG1				T65									
	G60L	VIN45	SG5				T63									
	G58L	VIN51	SG6				T60									
	G56L	VIN53	SG6				T58									
Gain at 9dB for two drives	G68H	VIN39	SG3			Measure gain of each output relative to input	8.55	8.9	9.45	dB	0	0	ON	ON	00000000	11110000
	G65H	VIN41	SG2				T68									
	G63H	VIN43	SG1				T65									
	G60H	VIN45	SG5				T63									
	G58H	VIN51	SG6				T60									
	G56H	VIN53	SG6				T58									
Gain at 6dB for one drive in two-drive mode	G68L	VIN39	SG3			Measure gain of each output relative to input	5.6	6.1	6.4	dB	0	0	OFF	ON	00000000	00110000
	G65L	VIN41	SG2				T68									
	G63L	VIN43	SG1				T65									
	G60L	VIN45	SG5				T63									
	G58L	VIN51	SG6				T60									
	G56L	VIN53	SG6				T58									
Gain at 9dB for one drive in two-drive mode	G68H	VIN39	SG3			Measure gain of each output relative to input	8.55	9.1	9.45	dB	0	0	ON	OFF	00000000	11110000
	G65H	VIN41	SG2				T68									
	G63H	VIN43	SG1				T65									
	G60H	VIN45	SG5				T63									
	G58H	VIN51	SG6				T60									
	G56H	VIN53	SG6				T58									
Output gain ratio (composite/ S)	Δ68/65	VIN39	SG3			Calculate the gain ratio of two outputs.	-5	0	5	%	0	0	ON	ON	00000000	11110000
	Δ68/63	VIN41	SG2				T68									
	Δ65/63	VIN43	SG1				T65									

Continued on next page

Continued from preceding page.

Parameter	Symbol	Input signal			Out Point	Test Condition	Spec			unit	Control voltage		SW		I <sup>2</sup> C bus data (MSB-LSB)	
		Point	Signal	Freq			Mag	min	typ		max	V18	V38	S63	S65, S66, S56	DV1
Output gain ratio (component)	Δ60/58	V <sub>IN</sub> 45	SG5		709mV/p-p	Calculate the gain ratio of two outputs.	-5	0	5	0	0	ON	ON	00000000	11110000	
	Δ60/56	V <sub>IN</sub> 51	SG6		709mV/p-p											
	Δ58/56	V <sub>IN</sub> 53	SG6		709mV/p-p											
7MHz change rate for f characteristics of GAIN	F68L	V <sub>IN</sub> 39	SG3	7MHz	1Vp-p	Measure gain of each output relative to input and calculate the change rate for gain at 100kHz.	-2	-0.8	0.4	0	0	ON	ON	00000000	00110000	
	F65L	V <sub>IN</sub> 41	SG2	7MHz	714mV/p-p											
	F63L	V <sub>IN</sub> 43	SG1	7MHz	1Vp-p											
	F60L1	V <sub>IN</sub> 45	SG1	7MHz	1Vp-p											
	F58L1	V <sub>IN</sub> 51	SG4	7MHz	1Vp-p											
27MHz change rate for f characteristics of GAIN	F68H	V <sub>IN</sub> 39	SG3	27MHz	1Vp-p	Measure gain of each output relative to input and calculate the change rate for gain at 100kHz.		-33	-25	dB	0	0	ON	ON	00000000	00110000
	F65H	V <sub>IN</sub> 41	SG2	27MHz	714mV/p-p											
	F63H	V <sub>IN</sub> 43	SG1	27MHz	1Vp-p											
	F60H1	V <sub>IN</sub> 45	SG1	27MHz	1Vp-p											
	F58H1	V <sub>IN</sub> 51	SG4	27MHz	1Vp-p											
14MHz change rate for f characteristics of GAIN	F60L2	V <sub>IN</sub> 45	SG1	14MHz	1Vp-p	Measure gain of each output relative to input and calculate the change rate for gain at 100kHz.	-2.3	-1.1	0.1	dB	0	0	ON	ON	00001000	00110000
	F58L2	V <sub>IN</sub> 51	SG4	14MHz	1Vp-p											
	F56L2	V <sub>IN</sub> 53	SG4	14MHz	1Vp-p											
	F60H2	V <sub>IN</sub> 45	SG1	54MHz	1Vp-p											
	F58H2	V <sub>IN</sub> 51	SG4	54MHz	1Vp-p											
54MHz change rate for f characteristics of GAIN	F56H2	V <sub>IN</sub> 53	SG4	54MHz	1Vp-p	Measure gain of each output relative to input and calculate the change rate for gain at 100kHz.		-37	-30	dB					00001000	00110000
	G60E	V <sub>IN</sub> 9	SG8		700mV/p-p		5.6	6.1	6.4	dB	0	3	ON	OFF	10000000	00100000
	G58E	V <sub>IN</sub> 11	SG8		700mV/p-p											
Gain at RGB through One drive	G56E	V <sub>IN</sub> 73	SG8		700mV/p-p											
	F60E	V <sub>IN</sub> 9	SG9	10MHz	700mV/p-p	Measure gain of each output relative to input and calculate the change rate for gain at 100kHz.	-0.5	-0.1	0.5	dB	0	3	ON	OFF	10000000	00100000
	F58E	V <sub>IN</sub> 11	SG9	10MHz	700mV/p-p											
F56E	V <sub>IN</sub> 73	SG9	10MHz	700mV/p-p												
Gain at RGB standby One drive	G60E	V <sub>IN</sub> 9	SG8		700mV/p-p	Measure gain of each output relative to input.	5.6	5.9	6.4	dB	3	3	ON	OFF		
	G58E	V <sub>IN</sub> 11	SG8		700mV/p-p											
	G56E	V <sub>IN</sub> 73	SG8		700mV/p-p											

Continued on next page.



Continued from preceding page.

Parameter	Symbol	Input signal			Out	Test Condition	Spec			unit	Control voltage	SW			I <sup>2</sup> C bus data (MSB+LSB)				
		Point	Signal	Freq			Mag	Point	min			typ	max	V18	V38	S63	S65, S60, S58, S56	DV1	DV2
MUTE voltage	V65MD					Measure the pin voltage.	2.1	2.5	2.9	0	0	ON	ON	00000010	00110000				
	V63MD						T65												
	V60MD						T63												
	V58MD						T60								00000001	00110000			
	V56MD						T58								00000100	00110000			
DC for SQ	V5Q					T66	4.1	4.4	4.7	0	0	ON	ON	00100000	00110000				
DC for LB	VLB					T66	2.05	2.2	2.35	0	0	ON	ON	00010000	00110000				
DC for 4 : 3	V43					T66	0	0	0.35	0	0	ON	ON	00000000	00110000				

**Design guarantee items**

Parameter	Symbol	Input signal				Out	Test Condition	Spec			unit	Control voltage	SW			I <sup>2</sup> C bus data (MSB+LSB)			
		Point	Signal	Freq	Mag			Point	min	typ			max	V18	V38	S63	S65, S60, S58, S56	DV1	DV2
f characteristics of group delay at 7MHz (interface)	GD68	VIN39	SG3	7MHz	1Vp-p	T68	Difference in group delay of 7MHz relative to 100kHz of each output	-20	10	20	0	0	ON	ON	00000000	00110000			
	GD65	VIN41	SG2	7MHz	714mVp-p	T65													
	GD63	VIN43	SG1	7MHz	1Vp-p	T63													
	GD60-1	VIN45	SG1	7MHz	1Vp-p	T60													
	GD58-1	VIN51	SG4	7MHz	714mVp-p	T58													
	GD56-1	VIN53	SG4	7MHz	714mVp-p	T56													
f characteristics of group delay at 14MHz (progressive)	GD60-2	VIN45	SG1	14MHz	1Vp-p	T60	Difference in group delay of 14MHz from 100kHz of each output	-15	5	15	0	0	ON	ON	00001000	00110000			
	GD58-2	VIN51	SG4	14MHz	714mVp-p	T58													
	GD56-2	VIN53	SG4	14MHz	714mVp-p	T56													
DG	DG68	VIN39	SG7	3.58MHz	1Vp-p	T68	Calculate the ratio in percentage of the amplitude of SIN wave on the white level relative to that of SIN wave on the black level of each output signal.		1	2	0	0	ON	ON	00000000	00110000			
	DG63	VIN43	SG7	3.58MHz	1Vp-p	T63													
	DG60	VIN45	SG7	3.58MHz	1Vp-p	T60													
	DGMIX	VIN41	SG2	3.58MHz	286mVp-p	T68													
		VIN43	SG7	Y only component	1Vp-p														

Continued on next page

Continued from preceding page.

Parameter	Symbol	Input signal				Out	Test Condition	Spec			unit	Control voltage		SW			I <sup>2</sup> C bus data (MSB+LSB)		
		Point	Signal	Freq	Mag			Point	min	typ		max	V'18	V'38	S63	S65, S60, S58, S56	DV1	DV2	
DP	DP68	V <sub>IN</sub> 39	SG7	3.58MHz	1Vp-p	T68	Measure the difference in phase of the SIN wave on the black level of each output signal relative to that of SIN wave on the white level.	-1	0.5	1	deg	0	0	ON	ON	00000000	00110000		
	DP63	V <sub>IN</sub> 43	SG7	3.58MHz	1Vp-p	T63													
	DP60	V <sub>IN</sub> 45	SG7	3.58MHz	1Vp-p	T60													
Crosstalk	DPMIX	V <sub>IN</sub> 41	SG2	3.58MHz	286mVp-p	T68	Measure the 4MHz component of the output of non-input route and calculate its ratio relative to the 4MHz amplitude of other outputs.									01000000	00110000		
		V <sub>IN</sub> 43	SG7	Y only component	1Vp-p														
	CT68	V <sub>IN</sub> 39	SG3	4MHz	1Vp-p	T68													
	CT65	V <sub>IN</sub> 41	SG2	4MHz	714mVp-p	T65													
	CT63	V <sub>IN</sub> 43	SG1	4MHz	1Vp-p	T63													
	CT60	V <sub>IN</sub> 45	SG1	4MHz	1Vp-p	T60													
Video S/N ratio	SN68	V <sub>IN</sub> 39	SG5		1Vp-p	T68	Measure the S/N ratio of output signal with a noise meter (LPF 10MHz, HPF 100kHz) and express it in dB.												
		V <sub>IN</sub> 43	SG5		1Vp-p	T63													
	SN63	V <sub>IN</sub> 43	SG5		1Vp-p	T60													
	SN60	V <sub>IN</sub> 45	SG5		1Vp-p	T60													
	SNMIX	V <sub>IN</sub> 43	SG5		1Vp-p	T68													

# LA73033M

## Block Diagram and Test Circuits

www.DataSheet4U.com

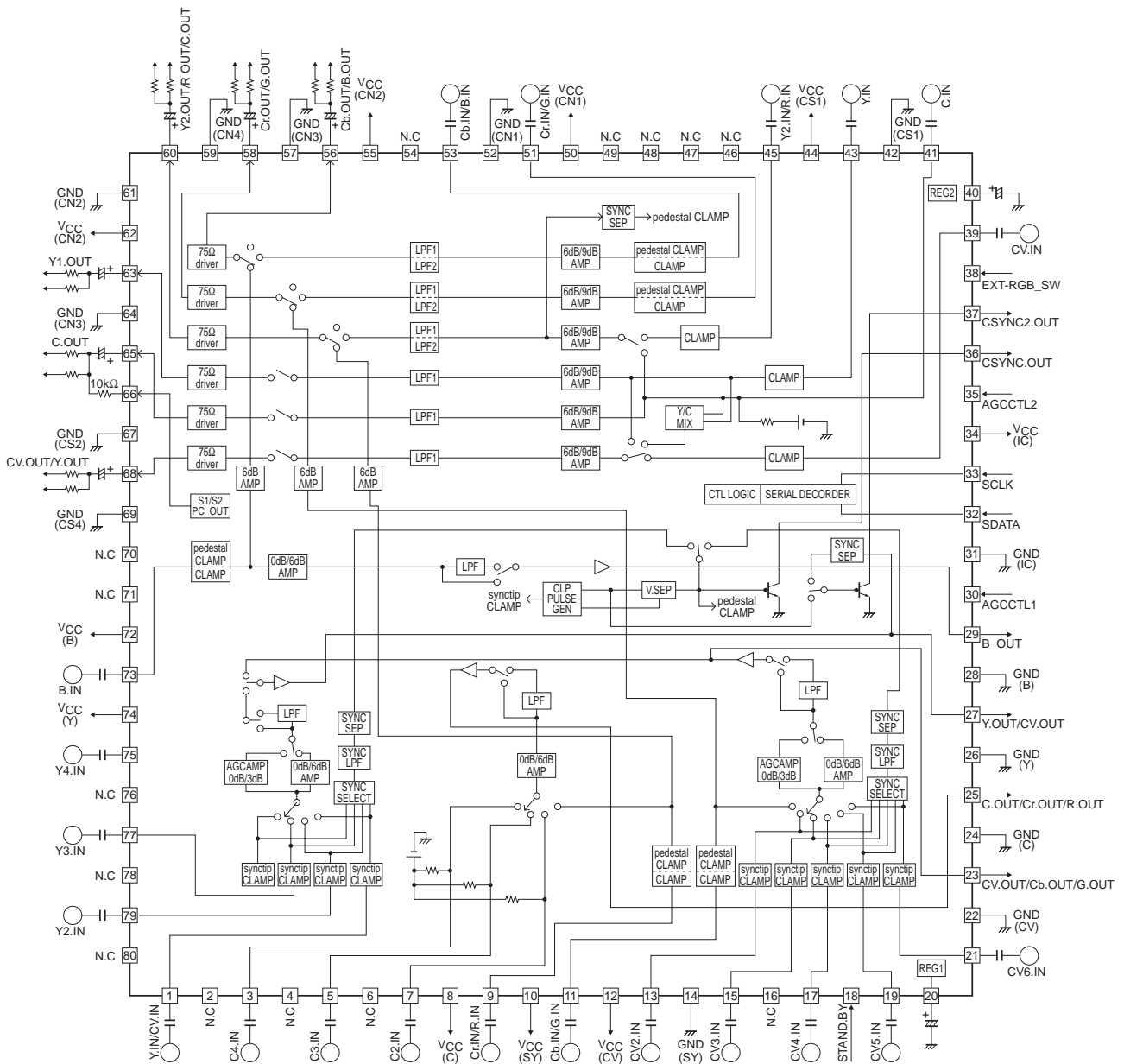

# LA73033M

## Pin Functions

Pin No.	Pin name	I/O	Impedance	DC voltage	Pin Explanation	Input/Output form
13	CV2.IN	I	Clamp Form	1.5V at 0dB	Recommended clamp capacitor = 0.1μF. For the selected pin, keyed clamp is applied to the input so that the clamp voltage of the output signal becomes constant when the signal is provided. Diode clamp is applied to the input when there is no signal. When no pin is selected and at CS-REC, diode clamp is applied to the input regardless of whether or not the signal is provided.	
15	CV3.IN			2.1V at 6dB		
17	CV4.IN			1.5V at AGC		
19	CV5.IN			1.5V at no selection		
21	CV6.IN			1.5V at no signal		
1	Y1.IN / CV.IN			CS-REC : 1.5V		
79	Y2.IN	I	10kΩ	2.9V	Recommended capacitor = 0.1μF. DC is overlapped over the signal through external C connection regardless of whether there is a signal or the pin is selected or AMP-GAIN in the mode other than CS-REC.	
77	Y3.IN					
75	Y4.IN					
5	C3.IN					
3	C4.IN	I	Clamp Form	For component 3.2V at 0dB 3.0V at 6dB For RGB 2.2V at 0dB 2.5V at 6dB For RGB through 2.3V 1.2V at no selection 1.2V at no signal to pin 1	Recommended clamp capacitor = 0.1μF. For the selected signal, keyed clamp is applied to the input so that the clamp voltage of output signal becomes constant when there is a signal to pin 1. Diode clamp is applied to the input when there is no signal at pin 1 or when the pin is not selected. For RGB through, feedback clamp is applied from the output to the input.	
9	Cr.IN R.IN					
73	B.IN					
23	CV.OUT Cb.OUT G.OUT	O	4.5Ω	0.8V for CV/ Y	The signal that has been selected and keyed clamped (excluding chroma) is amplified and output from the emitter follower. The constant current of emitter follower is 2.5mA when the built-in LPF is selected and 7.5mA when it is not selected.	
25	C.OUT Cr.OUT R.OUT			2.5V for component 1.25V for RGB For chroma output		
27	Y.OUT CV.OUT			2.2V at 0dB		
29	B.OUT			2.4V at 6dB		

Continued on next page.

# LA73033M

Continued from preceding page.

www.DataSheet4U.com

Pin No.	Pin name	I/O	Impedance	DC voltage	Pin Explanation	Input/Output form
18	STAND-BY-SW	I	17GΩ	Hi : 3.3V Lo : 0V	Normal mode when pins 18 and 38 are "L." RGB through mode when pin 18 is "L" and pin 38 is "H." RGB standby mode when pins 18 and 38 are "H." CS-REC mode when pin 18 is "H" and pin 38 is "L."	
38	EXT-RGB-SW					
20	SW-REG-FILT	O	880Ω	With pin 18 = L, Pin 20 : 2.5V Pin 40 : 2.0V 1With pin 18 = H, Pin 20 : 0V Pin 40 : 0V	Output pin for regulator voltage in IC. S/ N improvement measures recommended by inserting a capacitor of about 470μF between this pin and GND. The amplifier reference voltage on the SW side is based on the regulator voltage of pin 20 and that on the driver side is based on the regulator voltage of pin 40.	
40	DV-REG-FILT					
30	AGCCTL1 (CV)	I	128MΩ	Hi : 5V Lo : 2V Center : 3.3V	Pin to control gain of composite and Y signals when AGC-AMP is used. To suppress crosstalk, it is recommended to insert a noise suppressing capacitor near the pin between the pin and GND.	
35	AGCCTL2 (Y)					
36	C.SYNC OUT	I	480Ω	Hi : 5V Lo : 0.3V	Composite sink output pin Lo (sink) at SYNC Pin 36 can be used for detection of no-signal because LPF is applied. Pin 37 is for detection of the weak electric field. Pin 37 can be changed to V.SYNC-OUT.	
37	C.SYNC OUT2					

Continued on next page.

# LA73033M

Continued from preceding page.

www.DataSheet4U.com

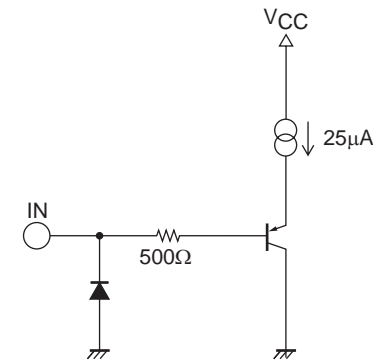
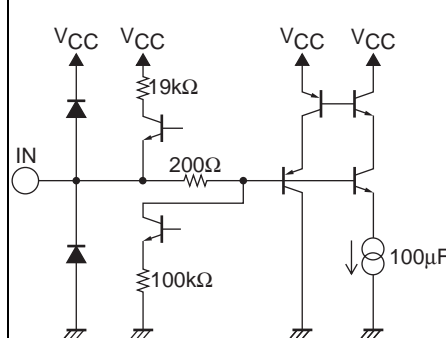
Pin No.	Pin name	I/O	Impedance	DC voltage		Pin Explanation	Input/Output form
					Description of each pin		
72	V <sub>CC</sub> (B)	P		5V	Description of each pin	V <sub>CC</sub> on the input SW. To avoid crosstalk, it is recommended to insert a capacitor between each V <sub>CC</sub> and GND. Keep V <sub>CC</sub> always ON.	V <sub>CC</sub> for pin 73 input
74	V <sub>CC</sub> (Y)						V <sub>CC</sub> for input of pins 1, 79, 77, and 75
8	V <sub>CC</sub> (C)						V <sub>CC</sub> for input of pins 9, 7, 5, and 3
10	V <sub>CC</sub> (SY)						V <sub>CC</sub> for input of pins 11, 13, 15, 17, 19, and 21
12	V <sub>CC</sub> (CV)						V <sub>CC</sub> for SYNC-SEP, clamp pulse
14	GND (SY)	P		0V	Description of each pin	GND on the input SW side	GND for pin 73 input
22	GND (CV)						GND for input of pins 1, 79, 77, and 75
24	GND (C)						GND for input of pins 9, 7, 5, and 3
26	GND (Y)						GND for pins 11, 13, 15, 17, 19, and 21
28	GND (B)						GND for SYNC-SEP, clamp pulse
76	NC			0V		NC pins on the input SW side. It is recommended to connect this to GND on the substrate to avoid interference between input signals.	
78	NC						
80	NC						
2	NC						
4	NC						
6	NC						
16	NC						
32	SDATA	I	734MΩ	Hi : 5V Lo : V		Pin to enter the serial data and its clock for IIC bus. For the input waveform, refer to the SDA & SCL standard.	
33	SCLK						
39	CV.IN	I	Clamp Form	2.2V at 6dB 2.3V at 9dB 1.85V at no signal		Recommended capacitor = 0.1μF. For the signal with input, feedback clamp is applied to the input so that the clamp voltage becomes constant. For signal without input, diode clamp is applied to the input. Pins 39 and 45 drop to 0 to 1V when not selected.	
43	Y1.IN						
45	Y2.IN R.IN						

Continued on next page.

# LA73033M

Continued from preceding page.

www.DataSheet4U.com

Pin No.	Pin name	I/O	Impedance	DC voltage	Pin Explanation	Input/Output form
41	C.IN	I	10kΩ	2.7V	Recommended capacitor = 0.1μF. DC is overlapped over the signal with external C connected, regardless of the signal or no-signal and AMP-GAIN.	
51	Cr.IN G.IN	I	Clamp Form	For component 2.8V at 6dB 2.7V at 9dB For RGB 2.2V at 6dB 2.3 at 9dB 1.85V at no signal	Recommended capacitor = 0.1μF. In the component mode, keyed clamp is applied to the input so that the pedestal of output signal becomes constant when there is a signal at pin 45. In the RGB mode, feedback clamp is applied to the input so that the output signal clamp voltage becomes constant. Diode clamp is applied to the input when there is no signal.	
53	Cb.IN B.IN					
68	CV.OUT Y1.OUT	O	4Ω	1.3V for CV/ Y/ RGB 2.5V for component For chroma output	Recommended coupling capacitor = 470μF (0.1μF for chroma). The signal that has passed AMP & LPF is output from the 75Ω driver. Two drives possible. It is recommended to provide this capacitor as near as possible to the pin to avoid interference.	
65	C.OUT			2.4V at 0dB 2.6V at 6dB		
63	Y1.OUT					
60	Y2.OUT R.OUT C.OUT					
58	Cr.OUT G.OUT					
56	Cb.OUT B.OUT					
66	C_DC OUT	O	11Ω	Hi : 4.4V Mid : 2.2V Lo : 0V	Circuit to output the DC voltage of S1 and S2 standards. When using this pin, insert a resistor (driving with about 10 kΩ per drive) between the output chroma signal after coupling and this pin, so that the DC voltage of S1 and S2 standard can be overlapped.	
34	V <sub>CC</sub> (IC)	P		5V	Description of each pin  V <sub>CC</sub> on the output driver side. It is recommended to insert a capacitor between each V <sub>CC</sub> and GND to avoid crosstalk. Keep V <sub>CC</sub> normally ON.	V <sub>CC</sub> for input of pins 32 and 33
44	V <sub>CC</sub> (CS1)			V <sub>CC</sub> for input of pins 39, 41, and 43		
50	V <sub>CC</sub> (CN1)			V <sub>CC</sub> for input of pins 45, 51, and 53		
55	V <sub>CC</sub> (CN2)			V <sub>CC</sub> for output of pins 60, 58, and 56		
62	V <sub>CC</sub> (CS2)			V <sub>CC</sub> for output of pins 68, 65, and 63		

Continued on next page.

# LA73033M

Continued from preceding page.

[www.DataSheet4U.com](http://www.DataSheet4U.com)

Pin No.	Pin name	I/O	Impe dance	DC voltage		Pin Explanation	Input/Output form
31	GND (IC)	P		0V	Description of each pin	GND on the output driver side	GND for input of pins 32 and 33
42	GND (CS1)						GND for input of pins 39, 41, and 43
52	GND (CN1)						GND for input of 45, 51, and 53
57	GND (CN3)						GND for output of pin 56
59	GND (CN4)						GND for output of pin 58
61	GND (CN2)						GND for output of pins 60
64	GND (CS3)						GND for output of pins 63
67	GND (CS2)						GND for output of pin 65
69	GND (CS4)						GND for output of pin 68
46	NC			0V		NC pins on the output driver side. It is recommended to connect this pin to GND on the substrate to avoid interference with the input SW side.	
47	NC						
48	NC						
49	NC						
54	NC						
70	NC						
71	NC						



# LA73033M

## Device address

www.DataSheet4U.com

	Gr address	bit7 (MSB)	bit6	bit5	bit4	bit3	bit2	bit1	bit0 (LSB)
SW1	00000001	INSEL3	INSEL2	INSEL1	LPF	SWGAIN1	SWGAIN2	YOUT SEL	*Res
SW2	00000010	AGC	V.SYNC	*Res	*Res	CLPOFF1	CLPIUP	TEST2	TEST1
DR1	00000011	SCART	YC MIX	CDC2	CDC1	PROG	GB MUTE	YC MUTE	CP MUTE
DR2	00000100	CV/ S GAIN	CP GAIN	CV/ S DRIVE	CP DRIVE	SCART YC	*Res	*Res	CLPOFF2

\* Res means a reserved bit.

Initial state

## SW block

INSEL3 INSEL2 INSEL1	SW block input selection/mode changeover	INSEL3	INSEL2	INSEL1	Input selection	Mode
		0	0	0	IN1	Component
		0	0	1	IN1	RGB
		0	1	0	IN2	Composite/ S
		0	1	1	IN3	Composite/ S
		1	0	0	IN4	Composite/ S
		1	0	1	IN5	Composite/ S
		1	1	0	IN6	Composite/ S
		1	1	1	Prohibition	
LPF	SW block LPF	1 : LPF on			0 : LPF off	
SWGAIN1	SW block amplifier gain changeover 1 (for composite/ Y signal)	1 : +6dB (AGC used+3dB)			0 : 0dB	
SWGAIN2	SW block amplifier gain changeover 2 (C/ component/ RGB signal)	1 : +6dB (AGC used+3dB)			0 : 0dB	
YOUT SEL	SW block YOUT output selection	1 : Composite			0 : Y	
AGC	SW block AGC ON/OFF	1 : ON			0 : OFF	
V.SYNC	SYNC output changeover	1 : V-SYNC output			0 : C- SYNC output (for detection of weak field)	
CLPOFF1	Test mode (SW block input clamp OFF)	1 : Clamp OFF			0 : Clamp ON	
CLPIUP	Increase in SW block clamp current	1 : Increase in the clamp current			0 : Clamp current normal	
TEST2	C-SYNC output (TEST mode)	00 : C-SYNC (Normal)			01 : Clamp pulse	
TEST1		10 : Prohibition			11 : Macro vision gate	

## Driver block

SCART	Driver block component mode changeover	1 : SCART (RGB)	0 : Y/ Cb/ Cr
YC MIX	Driver block composite output selection	1 : Y/ C MIX	0 : Composite (Y/ C MIX OFF)
CDC2	Driver block C_DC output voltage	00 : Low (0V) 4 : 3mode	
CDC1		10 : High (5V) squeeze	11 : Prohibition
PROG	Driver block LPF changeover	1 : Progressive	0 : Interlace
GB MUTE	Driver block G/B MUTE	1 : MUTE ON	0 : MUTE OFF
YC MUTE	Driver block YC MUTE	1 : MUTE ON	0 : MUTE OFF
CP MUTE	Driver block component MUTE	1 : MUTE ON	0 : MUTE OFF
CV/ S GAIN	Driver block composite/ S amplifier gain	1 : +9dB	0 : +6dB
CP GAIN	Driver block component amplifier gain	1 : +9dB	0 : +6dB
CV/ S DRIVE	Driver block composite/ S output drive capacity	1 : Two-system drive	0 : One-system drive
CP DRIVE	Driver block component output drive capacity	1 : Two-system drive	0 : One-system drive
SCART YC	Driver block SCART YC mode changeover	1 : YC	0 : RGB
CLPOFF2	Test mode (driver block input clamp OFF)	1 : Clamp OFF	0 : Clamp ON

## \*Initial setting at power ON

	Gr address	data
SW1	00000001	01100010
SW2	00000010	00000000
DR1	00000011	01000000
DR2	00000100	00110000

# LA73033M

## Control pin function table (1)

www.DataSheet4U.com

\*For the serial control pin, enter 3.5 to 5V for H and 0 to 1.5V for L.

\*For the parallel control pin, enter 2.6 to 5V for H and 0 to 0.7V for L.

\*For all control pins, do not apply the voltage higher than the one applied to V<sub>CC</sub> or lower than the one applied to GND.

\*No control pin must be used in the OPEN state.

\*Values in the table are standard values. For SPEC, refer to the electrical characteristics.

### [Selection of the SW side input signal]

Control	Gr address 00000001	Gr address 00000010	Pin 18 Standby	Pin 38 RGB through	Input pin to be selected	Signal to be output			
						Pin 23	Pin 25	Pin 27	Pin 29
CV (rear 1)	010***1*	****0*00	L	H/ L	13 (CV) , 7 (C)	(CV)	C	CV	DC
S (rear 1)	010***0*	****0*00	L	H/ L	7 (C) , 79 (Y)	-	C	Y	DC
CV (rear 2)	011***1*	****0*00	L	H/ L	15 (CV) , 5 (C)	(CV)	C	CV	DC
S (rear 2)	011***0*	****0*00	L	H/ L	5 (C) , 77 (Y)	-	C	Y	DC
CV (front)	100***1*	****0*00	L	H/ L	17 (CV) , 3 (C)	(CV)	C	CV	DC
S (front)	100***0*	****0*00	L	H/ L	3 (C) , 75 (Y)	-	C	Y	DC
CV (tuner)	101***1*	****0*00	L	H/ L	19 (CV)	(CV)	DC	CV	DC
	101***0*	****0*00	L	H/ L	None	-	DC	DC	DC
CV (tuner)	110***1*	****0*00	L	H/ L	21 (CV)	(CV)	DC	CV	DC
	110***0*	****0*00	L	H/ L	None	-	DC	DC	DC
component	000*****	****0*00	L	L	1 (Cb) , 9 (Cr) , 1 (Y)	Cb	Cr	Y	DC
	000*****	****0*00	L	H	1 (Y)	-	-	Y	-
RGB	001*****	****0*00	L	L	11 (G) , 9 (R) , 1 (CV) , 73 (B)	G	R	CV	B
	001*****	****0*00	L	H	1 (CV)	-	-	CV	-
CS-REC	*****	*****	H	L	Pin 15 input→15 (CV)	-	-	-	-
	*****	*****	H	L	Pins 15+77 input→77 (Y)	-	-	-	-
	*****	*****	H	L	Pin 77 input→77 (Y)	-	-	-	-

(Note 1) (CV) : Though a signal is output, its use is not recommended.

(Note 2) DC : The DC voltage differing depending on the AMP-GAIN setting is output.

(Note 3) - : Either the signal is not output or should not be used because the DC voltage is abnormal if output.

### [Selection of the input signal for C.SYNC OUT]

Control	Gr address 00000001	Gr address 00000010	Pin 18 Standby	Pin 38 RGB through	Input pin to be selected	Signal to be output	
						C.SYNC	C.SYNC2
CV (rear 1)	010***1*	*0**0*00	L	H/ L	13 (CV)	C.SYNC	C.SYNC2
S (rear 1)	010***0*	*0**0*00	L	H/ L	79 (Y)	C.SYNC	C.SYNC2
CV (rear 2)	011***1*	*0**0*00	L	H/ L	15 (CV)	C.SYNC	C.SYNC2
S (rear 2)	011***0*	*0**0*00	L	H/ L	77 (Y)	C.SYNC	C.SYNC2
CV (front)	100***1*	*0**0*00	L	H/ L	17 (CV)	C.SYNC	C.SYNC2
S (front)	100***0*	*0**0*00	L	H/ L	75 (Y)	C.SYNC	C.SYNC2
CV (tuner)	101***1*	*0**0*00	L	H/ L	19 (CV)	C.SYNC	C.SYNC2
	101***0*	*0**0*00	L	H/ L	None	×	×
CV (tuner)	110***1*	*0**0*00	L	H/ L	21 (CV)	C.SYNC	C.SYNC2
	110***0*	*0**0*00	L	H/ L	None	×	×
component	000*****	*0**0*00	L	H/ L	1 (Y)	C.SYNC	C.SYNC2
RGB	001*****	*0**0*00	L	H/ L	1 (CV)	C.SYNC	C.SYNC2
V.SYNC	*****	*1**0*00	L	H/ L	Same as above	C.SYNC	V.SYNC
Monitor	*****	*0**0*01	L	H/ L	Same as above	Clamp pulse	C.SYNC2
	*****	*0**0*11	L	H/ L	Same as above	Macro gate pulse	C.SYNC2
CS-REC	*****	*****	H	L	Pin 15 input→15 (CV)	C.SYNC	×
	*****	*****	H	L	Pins 15 + 77 input→77 (Y)	C.SYNC	×
	*****	*****	H	L	Pin 77 input→77 (Y)	C.SYNC	×
RGB standby	*****	*****	H	H	1 (CV)	C.SYNC	×

# LA73033M

## Control pin function table (2)

www.DataSheet4U.com

### [SW side AMP-GAIN selection]

Control	Gr address 00000001	Gr address 00000010	Pin 18 Standby	Pin 38 RGB through	AMP-GAIN			
					Pin 23	Pin 25	Pin 27	Pin 29
CV/S	****00**	0***0*00	L	H/ L	(Fixed at 0dB)	Fixed at 0dB	Fixed at 0dB	DC
	****10**	0***0*00	L	H/ L	(Fixed at 6dB)	Fixed at 0dB	Fixed at 6dB	DC
	****01**	0***0*00	L	H/ L	(Fixed at 0dB)	Fixed at 6dB	Fixed at 0dB	DC
	****11**	0***0*00	L	H/ L	(Fixed at 6dB)	Fixed at 6dB	Fixed at 6dB	DC
	****00**	1***0*00	L	H/ L	(AGC0dB)	Fixed at 0dB	AGC0dB	DC
	****10**	1***0*00	L	H/ L	(AGC3dB)	Fixed at 0dB	AGC3dB	DC
	****01**	1***0*00	L	H/ L	(AGC0dB)	Fixed at 6dB	AGC0dB	DC
	****11**	1***0*00	L	H/ L	(AGC3dB)	Fixed at 6dB	AGC3dB	DC
component	000*00**	0***0*00	L	H/ L	Fixed at 0dB	Fixed at 0dB	Fixed at 0dB	DC
	000*10**	0***0*00	L	H/ L	Fixed at 0dB	Fixed at 0dB	Fixed at 6dB	DC
	000*01**	0***0*00	L	H/ L	Fixed at 6dB	Fixed at 6dB	Fixed at 0dB	DC
	000*11**	0***0*00	L	H/ L	Fixed at 6dB	Fixed at 6dB	Fixed at 6dB	DC
	000*00**	1***0*00	L	H/ L	Fixed at 0dB	Fixed at 0dB	AGC0dB	DC
	000*10**	1***0*00	L	H/ L	Fixed at 0dB	Fixed at 0dB	AGC3dB	DC
	000*01**	1***0*00	L	H/ L	Fixed at 6dB	Fixed at 6dB	AGC0dB	DC
	000*11**	1***0*00	L	H/ L	Fixed at 6dB	Fixed at 6dB	AGC3dB	DC
RGB	001*00**	0***0*00	L	H/ L	Fixed at 0dB	Fixed at 0dB	Fixed at 0dB	Fixed at 0dB
	001*10**	0***0*00	L	H/ L	Fixed at 0dB	Fixed at 0dB	Fixed at 6dB	Fixed at 0dB
	001*01**	0***0*00	L	H/ L	Fixed at 6dB	Fixed at 6dB	Fixed at 0dB	Fixed at 6dB
	001*11**	0***0*00	L	H/ L	Fixed at 6dB	Fixed at 6dB	Fixed at 6dB	Fixed at 6dB
	001*00**	1***0*00	L	H/ L	Fixed at 0dB	Fixed at 0dB	AGC0dB	Fixed at 0dB
	001*10**	1***0*00	L	H/ L	Fixed at 0dB	Fixed at 0dB	AGC3dB	Fixed at 0dB
	001*01**	1***0*00	L	H/ L	Fixed at 6dB	Fixed at 6dB	AGC0dB	Fixed at 6dB
	001*11**	1***0*00	L	H/ L	Fixed at 6dB	Fixed at 6dB	AGC3dB	Fixed at 6dB

(Note 1) Though a signal is output, its use is not recommended.

(Note 2) At the Gr address = 0000 0001 of CV/S, \*\*\* ~ does not contain 00\* ~ .

### [SW side LPF selection]

Control	Gr address 00000001	Gr address 00000010	Pin 18 Standby	Pin 38 RGB through	LPF route of each output	Load corresponding to each output
					Pins 23, 25, 27, 29	Pins 23, 25, 27, 29
LPF-ON	***1****	****0*00	L	H/ L	Pass	1kΩ
LPF-OFF	***0****	****0*00	L	H/ L	Through	330Ω

# LA73033M

## Control pin function table (3)

www.DataSheet4U.com

### [Driver side input signal selection]

Control	Gr address 00000011	Gr address 00000100	Pin 18 Standby	Pin 38 RGB through	Input pin to be selected					Signal to be output						
										Pin 68	Pin 65	Pin 63	Pin 60	Pin 58	Pin 56	
CV/ S component	00***000	****0**0	L	L	39 (CV)	41 (C)	43 (Y1)	45 (Y2)	51 (Cr)	53 (Cb)	CV	C	Y1	Y2	Cr	Cb
	00***010	****0**0	L	L	39 (CV)			45 (Y2)	51 (Cr)	53 (Cb)	CV	DC	DC	Y2	Cr	Cb
	00***001	****0**0	L	L	39 (CV)	41 (C)	43 (Y1)				CV	C	Y1	DC	DC	DC
Y/ C-MIX component	01***000	****0**0	L	L		41 (C)	43 (Y1)	45 (Y2)	51 (Cr)	53 (Cb)	CV	C	Y1	Y2	Cr	Cb
	01***010	****0**0	L	L		41 (C)	43 (Y1)	45 (Y2)	51 (Cr)	53 (Cb)	CV	DC	DC	Y2	Cr	Cb
	01***001	****0**0	L	L	39 (CV)	41 (C)	43 (Y1)				CV	C	Y1	DC	DC	DC
CV/ S RGB	10***000	****0**0	L	L	39 (CV)	41 (C)	43 (Y1)	45 (R)	51 (G)	53 (B)	CV	C	Y1	R	G	B
	10***010	****0**0	L	L	39 (CV)			45 (R)	51 (G)	53 (B)	CV	DC	DC	R	G	B
	10***001	****0**0	L	L	39 (CV)	41 (C)	43 (Y1)				CV	C	Y1	DC	DC	DC
YC/ MIX RGB	11***000	****0**0	L	L		41 (C)	43 (Y1)	45 (R)	51 (G)	53 (B)	CV	C	Y1	R	G	B
	11***010	****0**0	L	L		41 (C)	43 (Y1)	45 (R)	51 (G)	53 (B)	CV	DC	DC	R	G	B
	11***001	****0**0	L	L	39 (CV)	41 (C)	43 (Y1)				CV	C	Y1	DC	DC	DC
SCART Y/ C	10***000	****1**0	L	L		41 (C)	43 (Y1)		51 (G)	53 (B)	Y1	C	Y1	C	G	R
	10***010	****1**0	L	L		41 (C)	43 (Y1)		51 (G)	53 (B)	Y1	DC	DC	C	G	R
	10***100	****1**0	L	L		41 (C)	43 (Y1)				Y1	C	Y1	C	DC	DC
SCART Y/ C-MIX	11***000	****1**0	L	L		41 (C)	43 (Y1)		51 (G)	53 (B)	CV	C	Y1	C	G	R
	11***010	****1**0	L	L		41 (C)	43 (Y1)		51 (G)	53 (B)	CV	DC	DC	C	G	R
	11***100	****1**0	L	L		41 (C)	43 (Y1)				CV	C	Y1	C	DC	DC
CV/ S RGB through	*0***0*	****0**0	L	H	39 (CV)	41 (C)	43 (Y1)	9 (R)	11 (G)	73 (B)	CV	C	Y1	R	G	B
	*0***1*	****0**0	L	H	39 (CV)			9 (R)	11 (G)	73 (B)	CV	DC	DC	R	G	B
SCART Y/ C RGB through	*0***0*	****1**0	L	H		41 (C)	43 (Y1)	9 (R)	11 (G)	73 (B)	Y1	C	Y1	R	G	B
	*0***1*	****1**0	L	H			43 (Y1)	9 (R)	11 (G)	73 (B)	Y1	DC	DC	R	G	B
Y/ C-MIX RGB through	*1***0*	*****0	L	H		41 (C)	43 (Y1)	9 (R)	11 (G)	73 (B)	CV	C	Y1	R	G	B
	*1***1*	*****0	L	H		41 (C)	43 (Y1)	9 (R)	11 (G)	73 (B)	CV	DC	DC	R	G	B
RGB standby	*****	*****	H	H				9 (R)	11 (G)	73 (B)	-	-	-	R	G	B
CS-REC	*****	*****	H	L							-	-	-	-	-	-

(Note 1) Y1 is a Y signal for S and Y2 is a Y signal for component.

(Note 2) The mute voltage described in the table of electrical characteristics is output.

(Note 3) -: Either the signal is not output or should not be used because the DC voltage is abnormal if output.

# LA73033M

## Control pin function table (4)

www.DataSheet4U.com

### [Driver side AMP-GAIN selection]

Control	Gr address 0000011	Gr address 0000100	Pin 18 Standby	Pin 38 RGB through	AMP-GAIN					
					Pin 68	Pin 65	Pin 63	Pin 60	Pin 58	Pin 56
DAC signal	****000	00****00	L	L	6dB	6dB	6dB	6dB	6dB	6dB
	****000	10****00	L	L	9dB	9dB	9dB	6dB	6dB	6dB
	****000	01****00	L	L	6dB	6dB	6dB	9dB	9dB	9dB
	****000	11****00	L	L	9dB	9dB	9dB	9dB	9dB	9dB
DAC signal RGB through	****000	0****00	L	H	6dB	6dB	6dB	6dB	6dB	6dB
	****000	1****00	L	H	9dB	9dB	9dB	6dB	6dB	6dB
RGB standby	*****	*****	H	H	-	-	-	6dB	6dB	6dB

(Note 1) At SCART-YC, the gain control of chroma output is different between pin 65 and pin 60.

(Note 2) -: Either the signal is not output or should not be used because the DC voltage is abnormal if output.

### [Driver side LPF selection]

Control	Gr address 0000001	Gr address 0000100	Pin 18 Standby	Pin 38 RGB through	LPF cut-off frequency (MHz)					
					Pin 68	Pin 65	Pin 63	Pin 60	Pin 58	Pin 56
Interlace	****1***	*****00	L	L	9	9	9	9	9	9
Progressive	****0***	*****00	L	L	9	9	9	18	18	18
RGB through	*****	*****00	L	H	9	9	9	Through	Through	Through
RGB standby	*****	*****	H	H	-	-	-	Through	Through	Through

### [Selection of the number of channels that can be driven by 75Ω driver ]

Control	Gr address 0000001	Gr address 0000100	Pin 18 Standby	Pin 38 RGB through	Number of channels that can be driven of each output					
					Pin 68	Pin 65	Pin 63	Pin 60	Pin 58	Pin 56
DAC signal	****000	**00***0	L	L	1	1	1	1	1	1
	****000	**10***0	L	L	2	2	2	1	1	1
	****000	**01***0	L	L	1	1	1	2	2	2
	****000	**11***0	L	L	2	2	2	2	2	2
DAC signal RGB through	*****0*	**00***0	L	H	1	1	1	1	1	1
	*****0*	**10***0	L	H	2	2	2	1	1	1
	*****0*	**01***0	L	H	1	1	1	2	2	2
	*****0*	**11***0	L	H	2	2	2	2	2	2
RGB standby	*****	*****	H	H	-	-	-	1	1	1

### [Selection of S1 and S2 overlapping DC]

Control	Gr address 0000001	Gr address 0000100	Pin 18 Standby	Pin 38 RGB through	Pin 66	
					Application	Output voltage (V)
For S1 and S2 control	**00****	*****0	L	H/ L	For 4 : 3	0
	**01****	*****0	L	H/ L	For letter box	2.2
	**10****	*****0	L	H/ L	For squeeze	4.4
	**11****	*****0	L	H/ L	Prohibited	-

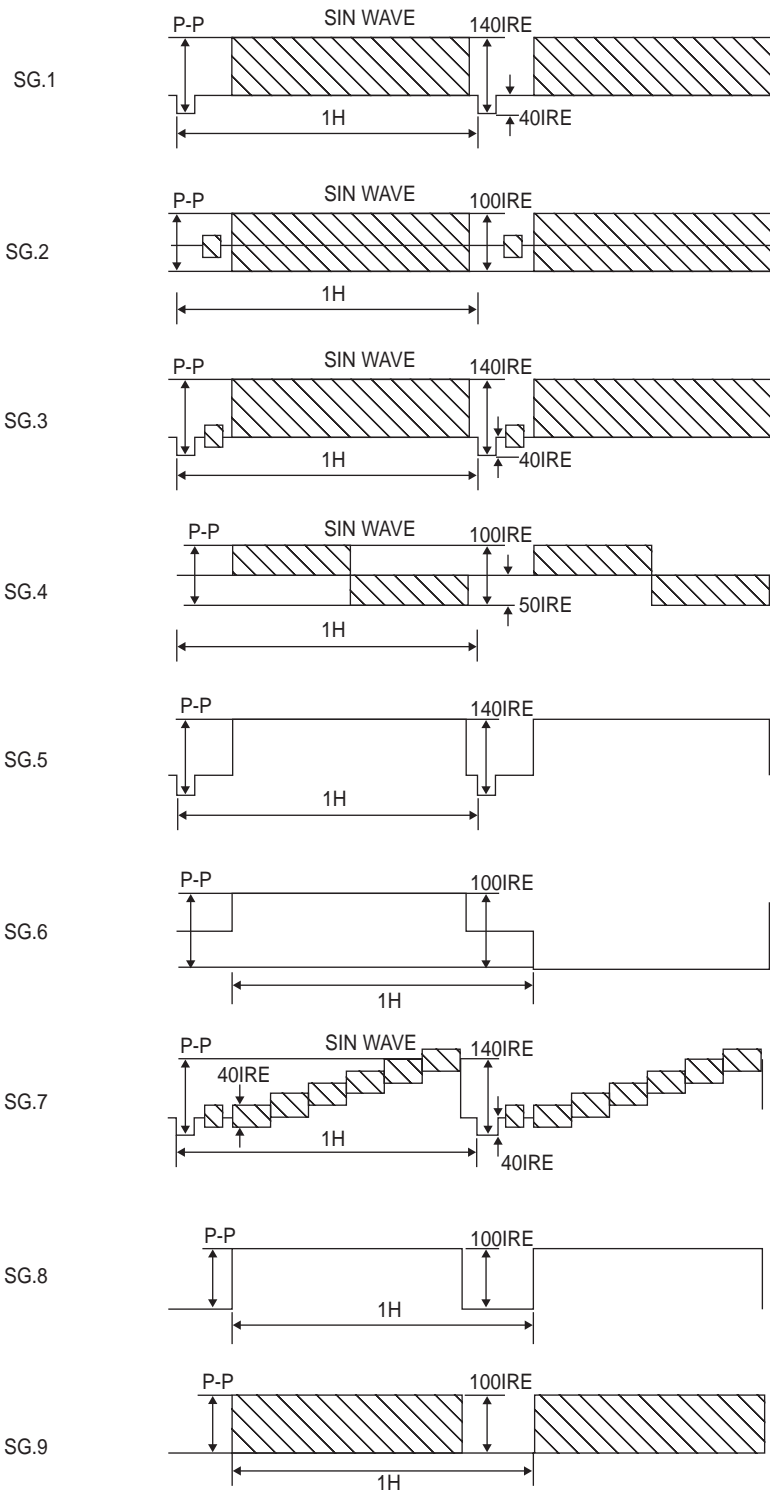

# LA73033M

## Sample Application

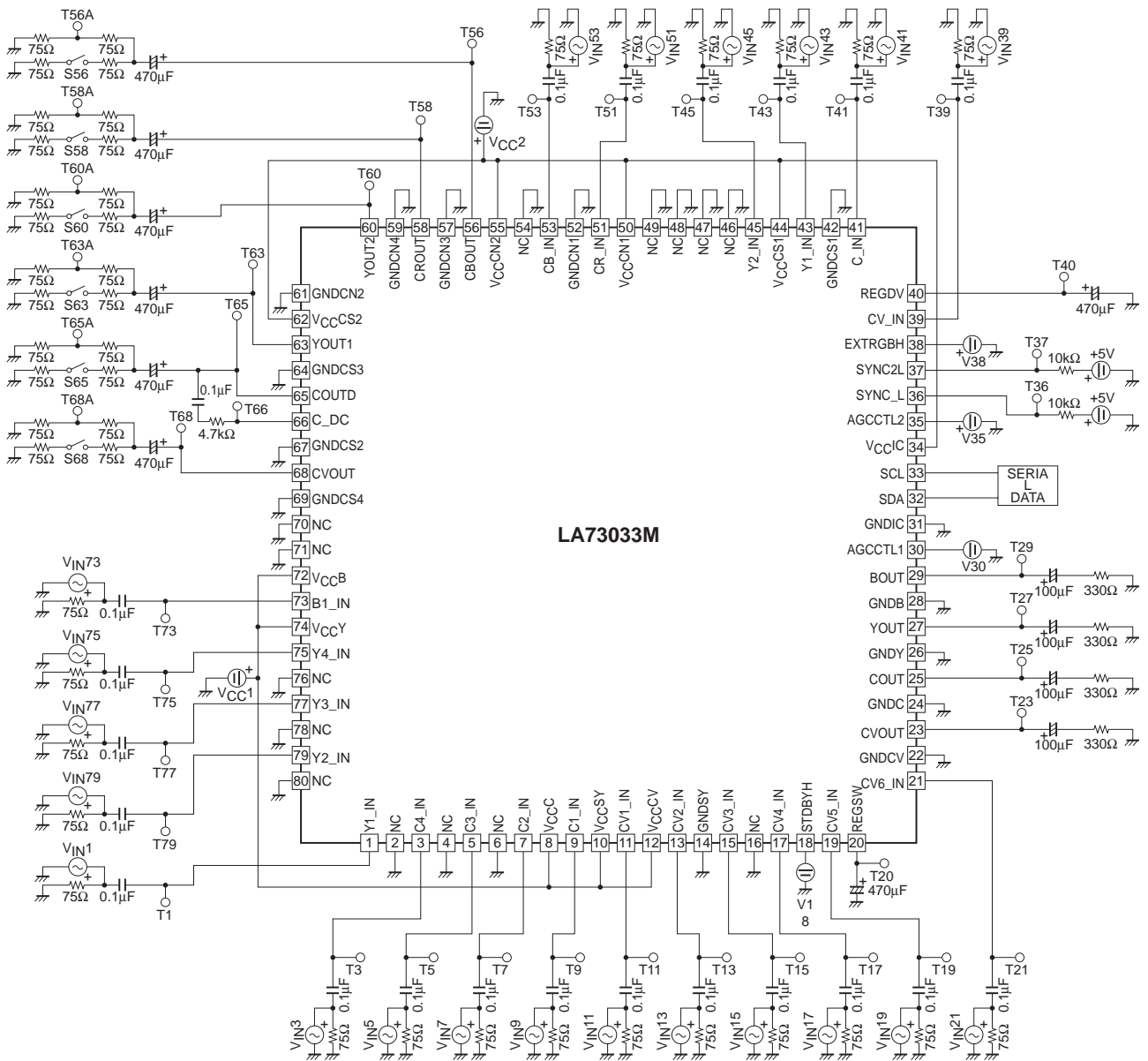

- SANYO Semiconductor Co.,Ltd. assumes no responsibility for equipment failures that result from using products at values that exceed, even momentarily, rated values (such as maximum ratings, operating condition ranges, or other parameters) listed in products specifications of any and all SANYO Semiconductor Co.,Ltd. products described or contained herein.
- SANYO Semiconductor Co.,Ltd. strives to supply high-quality high-reliability products, however, any and all semiconductor products fail or malfunction with some probability. It is possible that these probabilistic failures or malfunction could give rise to accidents or events that could endanger human lives, trouble that could give rise to smoke or fire, or accidents that could cause damage to other property. When designing equipment, adopt safety measures so that these kinds of accidents or events cannot occur. Such measures include but are not limited to protective circuits and error prevention circuits for safe design, redundant design, and structural design.
- In the event that any or all SANYO Semiconductor Co.,Ltd. products described or contained herein are controlled under any of applicable local export control laws and regulations, such products may require the export license from the authorities concerned in accordance with the above law.
- No part of this publication may be reproduced or transmitted in any form or by any means, electronic or mechanical, including photocopying and recording, or any information storage or retrieval system, or otherwise, without the prior written consent of SANYO Semiconductor Co.,Ltd.
- Any and all information described or contained herein are subject to change without notice due to product/technology improvement, etc. When designing equipment, refer to the "Delivery Specification" for the SANYO Semiconductor Co.,Ltd. product that you intend to use.
- Information (including circuit diagrams and circuit parameters) herein is for example only; it is not guaranteed for volume production.
- Upon using the technical information or products described herein, neither warranty nor license shall be granted with regard to intellectual property rights or any other rights of SANYO Semiconductor Co.,Ltd. or any third party. SANYO Semiconductor Co.,Ltd. shall not be liable for any claim or suits with regard to a third party's intellectual property rights which has resulted from the use of the technical information and products mentioned above.

This catalog provides information as of July, 2007. Specifications and information herein are subject to change without notice.