



SANYO Semiconductors

DATA SHEET

LA75525VA — Monolithic Linear IC For TV Sets and VCRs VIF/SIF Signal-Processing IC

Overview

The LA75525VA is a completely adjustment-free NTSC VIF/SIF signal-processing IC for TV sets and VCRs. It supports IF frequencies of 45.75 and 58.75MHz. It integrates an automatic adjustment circuit for the VCO, an AFT circuit, and an audio carrier trap circuit on the same chip and requires the input of either a 4MHz or 3.58MHz reference signal.

Features

- Automatic adjustment VCO (no external VCO coil is required).
- Built-in audio carrier trap; an external circuit may be used if desired.
- Digital AFT adopted.
- FM radio receiver function.

Specifications

Absolute Maximum Ratings at $T_a = 25^\circ\text{C}$

Parameter	Symbol	Conditions	Ratings	Unit
Maximum supply voltage	$V_{CC\ max}$		6	V
Circuit voltage	V12 V16		V_{CC}	V
Circuit current	I5		-3	mA
	I9		-7	mA
	I24		-2	mA
Allowable power dissipation	$P_d\ max$	$T_a \leq 75^\circ\text{C}$, Mounted on a circuit board *	500	mW
Operating temperature	T_{opr}		-20 to +75	$^\circ\text{C}$
Storage temperature	T_{stg}		-55 to +150	$^\circ\text{C}$

* Specified substrate: 65mm×72mm×1.6mm, glass epoxy.

■ Any and all SANYO Semiconductor Co.,Ltd. products described or contained herein are, with regard to "standard application", intended for the use as general electronics equipment (home appliances, AV equipment, communication device, office equipment, industrial equipment etc.). The products mentioned herein shall not be intended for use for any "special application" (medical equipment whose purpose is to sustain life, aerospace instrument, nuclear control device, burning appliances, transportation machine, traffic signal system, safety equipment etc.) that shall require extremely high level of reliability and can directly threaten human lives in case of failure or malfunction of the product or may cause harm to human bodies, nor shall they grant any guarantee thereof. If you should intend to use our products for applications outside the standard applications of our customer who is considering such use and/or outside the scope of our intended standard applications, please consult with us prior to the intended use. If there is no consultation or inquiry before the intended use, our customer shall be solely responsible for the use.

■ Specifications of any and all SANYO Semiconductor Co.,Ltd. products described or contained herein stipulate the performance, characteristics, and functions of the described products in the independent state, and are not guarantees of the performance, characteristics, and functions of the described products as mounted in the customer's products or equipment. To verify symptoms and states that cannot be evaluated in an independent device, the customer should always evaluate and test devices mounted in the customer's products or equipment.

SANYO Semiconductor Co., Ltd.

TOKYO OFFICE Tokyo Bldg., 1-10, 1 Chome, Ueno, Taito-ku, TOKYO, 110-8534 JAPAN

LA75525VA

Recommended Operating Conditions at Ta = 25°C

Parameter	Symbol	Conditions	Ratings	Unit
Recommended supply voltage	V _{CC}		5	V
Operation supply voltage	V _{CC op}		4.5 to 5.5	V

Electrical Characteristics at Ta = 25°C, V_{CC}=5V, S7, S9: Short

Parameter	Symbol	Conditions	Ratings			unit
			min	typ	max	
VIF Block						
Circuit current (external trap)	I ₄ (EXT)	External Trap	53	63	73	mA
Max RFAGC voltage	V _{14H}		V _{CC} -0.5	V _{CC}		V
Min RFAGC voltage	V _{14L}			0	0.5	V
Input sensitivity	V _i	Video out2	34	40	46	dBμV
AGC range	GR		58	63		dB
Max allowable input	V _i max		95	100		dBμV
Quiescent video output voltage	V ₅		2.2	2.5	2.8	V
Sync signal edge voltage	V _{5tip}		0.8	1.0	1.2	V
Video output level	V _O	S7, S9: OPEN	1.1	1.3	1.5	Vp-p
Video output level (external trap)	V _{Ot}		0.89	1.05	1.21	Vp-p
Black noise threshold voltage	VBTH		0.40	0.65	0.90	V
Black noise clamp voltage	VBCL		1.2	1.5	1.8	V
Video S/N (external trap)	S/N (EXT)	External Trap	50	54		dB
C-S beat	ICS	P/C=P/S=10dB	38	43		dB
Frequency characteristics	F _c	6MHz	-3	-1.5		dB
Differential gain	DG			3	6.5	%
Differential phase	DP			3	5	deg
VIF input resistance	R _i			1.0		kΩ
VIF input capacity	C _i			3		pF
APC pull-in range (U)	F _{pu}		1.0	1.5		MHz
APC pull-in range (L)	F _{pl}			-2.0	-1.5	MHz
VCO1 maximum variable range (U)	D _{fu}		1.0	1.5		MHz
VCO1 maximum variable range (L)	D _{fl}			-2.0	-1.5	MHz
VCO control sensitivity	B		2	2.5	3	kHz/mV
1st SIF Block / 13Pin 41.25MHz input						
Conversion gain	VG	S=40dBμ	37	43	49	dB
SIF carrier output level	S _O	S=80dBμ	94	104	114	dBμV
SIF output gain	G _{bpf}	Reference to SIF input (Pin1)	0	3	6	dB
1st SIF max input	S _i max		100	110		dBμV
1st SIF input resistance	R _i (SIF)	41.25MHz		2		kΩ
1st SIF input capacity	C _i (SIF)	41.25MHz		3		pF
SIF Block / 1Pin 4.5MHz input						
Limiting sensitivity	V _{li} (TV)		50	56	62	dBμV
FM detection output voltage	V _O (TV)	+/-25kHz	420	600	780	mVrms
AMR	AMRTV		50	60		dB
Distortion factor	THDTV			0.3	0.8	%
SIF S/N	S/NTV		59	65		dB
Control Block						
FM/TV threshold level in US	V _{10usfmtv}		0.7	1.0	1.3	V
US/JP changeover threshold	V _{10usjp}		2.2	2.5	2.8	V
FM/TV threshold level in JPN	V _{10jpfmtv}		3.7	4.0	4.3	V
Inter carrier control voltage	V ₁₃				0.3	V

Package Dimensions

unit : mm (typ)

3287

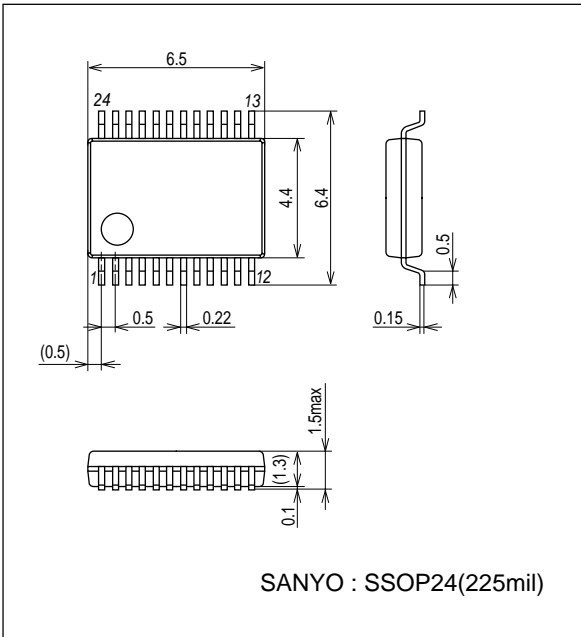

Pin Assignment

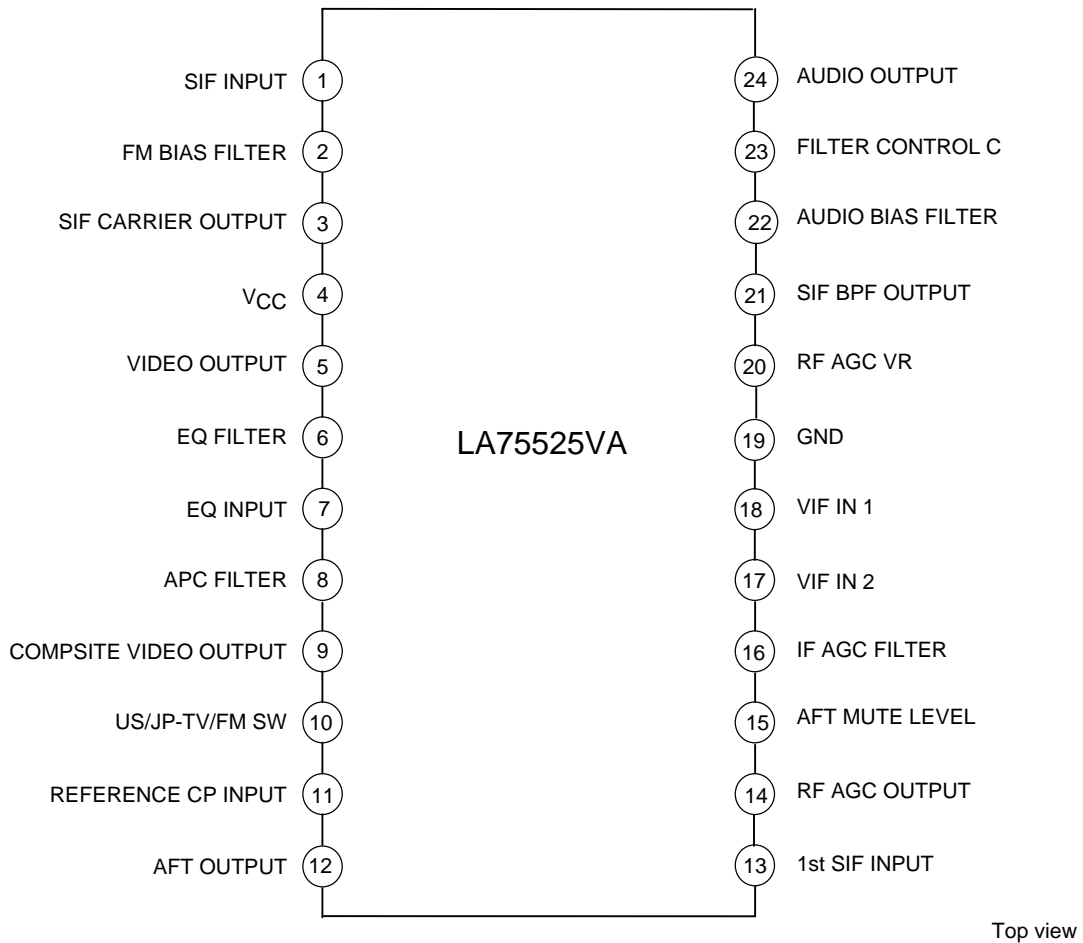

LA75525VA

Input Impedance Test Circuit (VIF, 1st SIF input impedance)

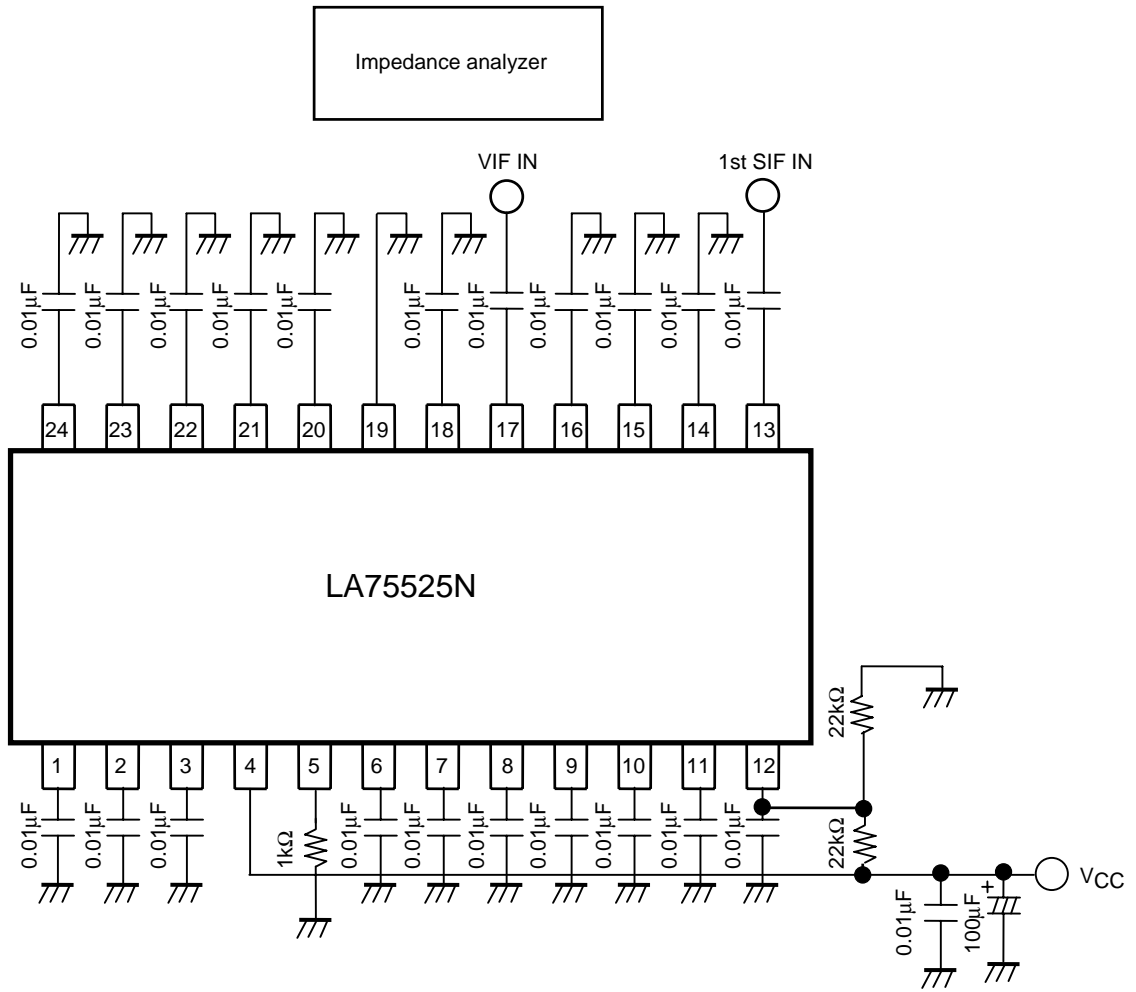

Block Diagram

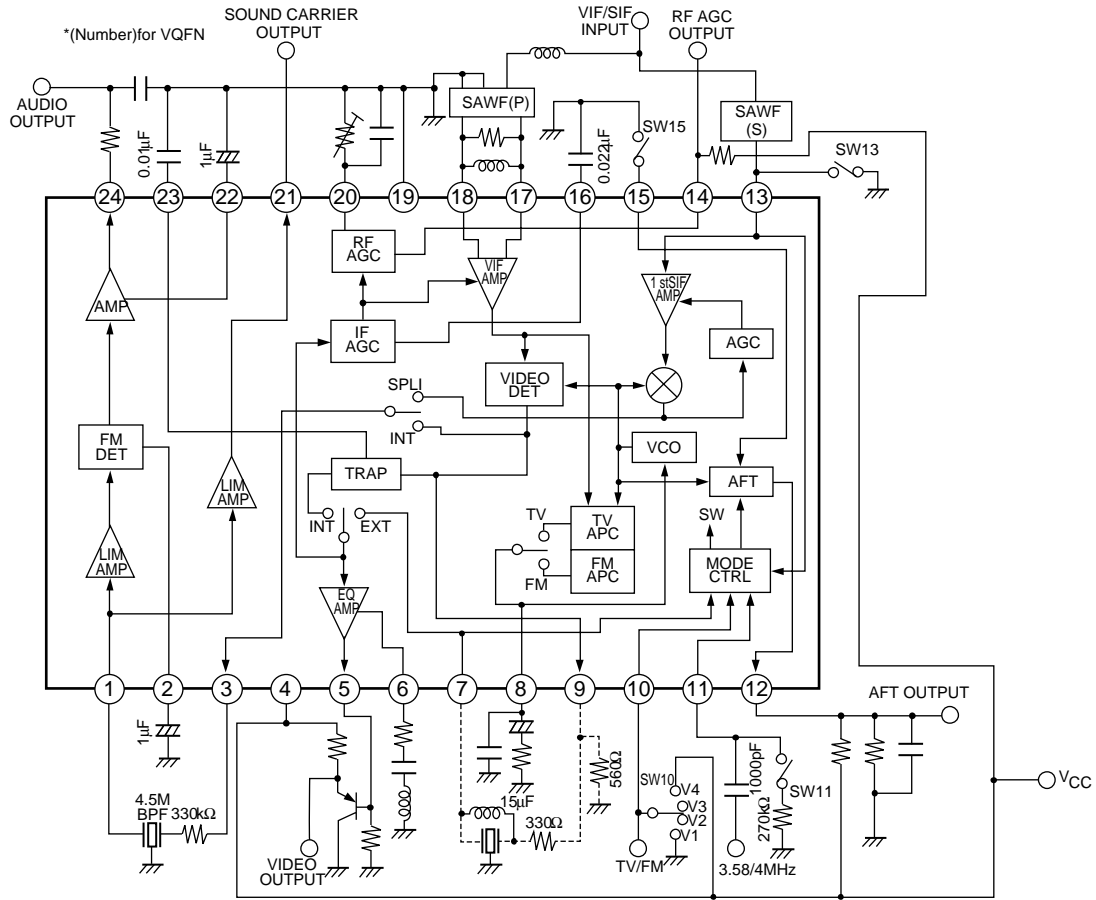

A: IF system SW

The IF frequency becomes 45.75MHz when pin 10 is open.
 The IF frequency becomes 58.75MHz when pin 10 is set to V_{CC}.

B: Split / Inter carrier SW

Inter-carrier is selected by setting the 1st SIF input (pin 13) to GND.

C: Reference frequency changeover SW

The reference frequency becomes 3.58MHz when pin 11 is set to "C-①."
 This frequency becomes 4.0MHz when this pin is set to "C-②."

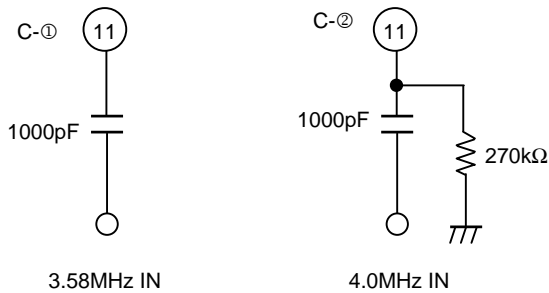

- SANYO Semiconductor Co.,Ltd. assumes no responsibility for equipment failures that result from using products at values that exceed, even momentarily, rated values (such as maximum ratings, operating condition ranges, or other parameters) listed in products specifications of any and all SANYO Semiconductor Co.,Ltd. products described or contained herein.
- SANYO Semiconductor Co.,Ltd. strives to supply high-quality high-reliability products, however, any and all semiconductor products fail or malfunction with some probability. It is possible that these probabilistic failures or malfunction could give rise to accidents or events that could endanger human lives, trouble that could give rise to smoke or fire, or accidents that could cause damage to other property. When designing equipment, adopt safety measures so that these kinds of accidents or events cannot occur. Such measures include but are not limited to protective circuits and error prevention circuits for safe design, redundant design, and structural design.
- In the event that any or all SANYO Semiconductor Co.,Ltd. products described or contained herein are controlled under any of applicable local export control laws and regulations, such products may require the export license from the authorities concerned in accordance with the above law.
- No part of this publication may be reproduced or transmitted in any form or by any means, electronic or mechanical, including photocopying and recording, or any information storage or retrieval system, or otherwise, without the prior written consent of SANYO Semiconductor Co.,Ltd.
- Any and all information described or contained herein are subject to change without notice due to product/technology improvement, etc. When designing equipment, refer to the "Delivery Specification" for the SANYO Semiconductor Co.,Ltd. product that you intend to use.
- Information (including circuit diagrams and circuit parameters) herein is for example only; it is not guaranteed for volume production.
- Upon using the technical information or products described herein, neither warranty nor license shall be granted with regard to intellectual property rights or any other rights of SANYO Semiconductor Co.,Ltd. or any third party. SANYO Semiconductor Co.,Ltd. shall not be liable for any claim or suits with regard to a third party's intellectual property rights which has resulted from the use of the technical information and products mentioned above.

This catalog provides information as of April, 2007. Specifications and information herein are subject to change without notice.