



LA7674

Color TV Single-Chip Signal Processor for NTSC Systems (PLL Detection)

Overview

The LA7674 improves upon the black-level, horizontal-jitter, switch-on drift performance of the single-chip LA7672 used to date. Also a single-chip IC, the LA7674 is for color TVs based on the NTSC (National Television System Committee) system with an on-chip circuit for all VIF, SIF, video, chroma and deflection signal processing.

Functions and Features

[VIF]

- PLL detection (high video and audio quality)
- High-gain VIF amplifier
- High speed AGC
- On-chip APC time constant switch

[SIF]

- Simultaneous sound IN/OUT
- Video/audio simultaneous muting, or audio-only muting possible

[Audio-visual switch]

- Internal/external audio-visual switch ($V_{CC} = 9V$)

Delay line	Video external, audio external	Switch rating
OFF	IN	6.9 to 9.0V
OFF	EXT	4.7 to 6.6V
ON	EXT	2.4 to 4.3V
ON	IN	0 to 2.1V

[OSD]

- RGB 3 input
- RGB linear amplifier (– 6dB input: 2V to 5V)
- Fast blanking (B input combined use)

[Chroma]

- On-chip ACC filter, On-chip killer filter, Killer-circuit hysteresis operation
- On-chip carrier filter

[Video]

- Black enhancement

- DC playback
- On-chip delay line
- Wide band width (9MHz): delay line short
- Dual rank on-chip differentiation circuit also available for soft also
- S input supported (VCR application)
- Variable DC transmission volume available (externally attached circuit adjustment)

[Deflection]

- Adjustment-free horizontal, vertical synchronization
- Dual AFC system with excellent anti-noise characteristics
- External adjustment of vertical synchronization sensitivity
- Vertical size is constant with no-signal
- Highly stable image during playback of copy protected tapes (macro-vision tape etc.)
- High stability against VCR skew distortion

Package Dimensions

unit: mm

3128-DIP52S

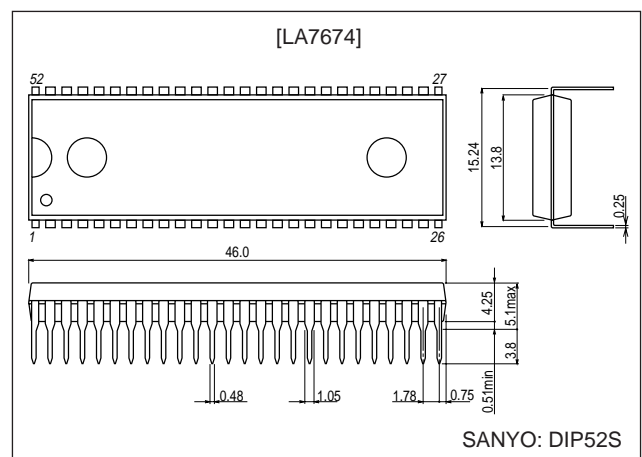

■ Any and all SANYO products described or contained herein do not have specifications that can handle applications that require extremely high levels of reliability, such as life-support systems, aircraft's control systems, or other applications whose failure can be reasonably expected to result in serious physical and/or material damage. Consult with your SANYO representative nearest you before using any SANYO products described or contained herein in such applications.

■ SANYO assumes no responsibility for equipment failures that result from using products at values that exceed, even momentarily, rated values (such as maximum ratings, operating condition ranges, or other parameters) listed in products specifications of any and all SANYO products described or contained herein.

SANYO Electric Co., Ltd. Semiconductor Company

TOKYO OFFICE Tokyo Bldg., 1-10, 1 Chome, Ueno, Taito-ku, TOKYO, 110-8534 JAPAN

Specifications

Absolute Maximum Ratings at $T_a = 25^\circ\text{C}$

Parameter	Symbol	Conditions	Ratings	Unit
Maximum supply voltage	V11 max		11	V
	V14 max		11	V
Maximum supply current	I30max		16	mA
Allowable power dissipation	Pd max	$T_a \leq 60^\circ\text{C}$	1.35	W
Operating temperature range	Topr		-10 to +65	$^\circ\text{C}$
Storage temperature range	Tstg		-55 to +150	$^\circ\text{C}$
Circuit current	I44		-6	mA
	I6		-3	mA
FBP input current	I22 max	Peak current	5	mA
	I21 max	Peak current	10	mA

Operating Conditions at $T_a = 25^\circ\text{C}$

Parameter	Symbol	Conditions	Ratings	Unit
Recommended supply voltage	V11		9	V
	V14		9	V
Recommended supply current	I30		13	mA
Operating voltage range	V11op		8 to 9.5	V
	V14op		8 to 9.5	V
Operating current range	I30op		10 to 16	mA

Operating Characteristics at $T_a = 25^\circ\text{C}$, $V_{CC} = V11 = V14 = 9\text{V}$, $I_{CC} = I30 = 13\text{mA}$

Parameter	Symbol	Conditions	Ratings			Unit
			min	typ	max	
[Circuit Voltage and Current]						
Horizontal supply voltage	V30	$V_{CC} = 9\text{V}$, $I_{CC} = 13\text{mA}$	7.3	7.8	8.3	V
Supply current	I11 + 14	$V_{CC} = 9\text{V}$, $I_{CC} = 13\text{mA}$, I_F AGC 4V	102	120	138	mA
[VIF]						
Quiescent video output voltage	V44	Quiescent	4.3	4.7	5.1	V
Quiescent AFT output voltage	V47	Quiescent	3.1	4.7	6.1	V
Maximum RFAGC voltage	V49H	$CW = 85\text{dB}\mu$, RFAGCVR = min	7.6	8.0	8.3	V
Minimum RFAGC voltage	V49L	$CW = 85\text{dB}\mu$, RFAGCVR = max	0	0.01	0.3	V
Input sensitivity	V_i	VIF input level for video output at 0.8Vp-p (40% mod).	33	39	45	dB μ
AGC range	GR	Maximum input ($V_0 = 0.8\text{Vp-p}$) - input sensitivity	54	62	70	dB
Maximum permissible input	V_i max	VIF input level for video output at +1dB	97	104	111	dB μ
Video output detection	V_{O44}	$V_i = 80\text{dB}\mu$, AM = 78% mod	1.7	2.0	2.3	Vp-p
Differential gain	DG	$V_i = 80\text{dB}\mu$, AM = 87.5%, video mod		3.0	10	%
Differential phase	DP	$V_i = 80\text{dB}\mu$, AM = 87.5%, video mod		1.0	10	DEG
Video S/N	S/N	$V_i = 80\text{dB}\mu$, 20 log $\frac{1.46 (Vp-p)}{\text{noise } (V_{rms})}$	47	54	61	dB
Synchronization signal tip level	V44 TIP	$CW = 80\text{dB}\mu$	2.1	2.4	2.7	V
Frequency characteristic	f_C	Frequency at video output of -3dB	6.0	9.0	12.0	MHz
920 kHz VIF intermodulation	I920	V3.58MHz/V920kHz, $V_i = 80\text{dB}\mu$	35	42	49	dB
Maximum AFT output voltage	V47H	$CW = 80\text{dB}\mu$, frequency change	8.3	8.7	9.0	V
Minimum AFT output voltage	V47L	$CW = 80\text{dB}\mu$, frequency change	0.1	0.3	0.8	V
AFT detection sensitivity	Sf	$CW = 80\text{dB}\mu$, frequency change	45	70	100	mV/kHz
AFT switch operation start voltage	V_{AFTSW}	Measuring with sweep signal	0.5	1.0	1.5	V
Black noise threshold level	V_{BTH}	Measuring with sweep signal	1.1	1.4	1.7	V
APC pull-in range (U)2	f_{PU-2}	$CW = 80\text{dB}\mu$, $f_P = 53\text{MHz}$ to 64MHz	0.8	1.7	4.0	MHz
APC pull-in range (L)2	f_{PL-2}	$CW = 80\text{dB}\mu$, $f_P = 53\text{MHz}$ to 64MHz		-2	-1	MHz
VCO maximum variable range	Δf_U	Quiescent	0.9	1.7	4.0	MHz
	Δf_L	Quiescent	-4	-2	-1	MHz
VCO control sensitivity	β	Quiescent	1.5	3.0	5.5	kHz/mV

Continued on next page.

LA7674

Continued from preceding page.

Parameter	Symbol	Conditions	Ratings			Unit
			min	typ	max	
[Audio-visual Switches]						
Video output DC voltage	V38	Quiescent	3.0	3.4	3.8	V
Internal video input voltage	V42	Quiescent	4.4	4.8	5.2	V
External video input voltage	V40	Quiescent	4.4	4.8	5.2	V
External audio input voltage	V3	Quiescent	5.2	5.6	6.0	V
[SIF AF]						
SIF limiting voltage	Vi lim	SIF output level for detection output at -3dB	33	40	47	dB μ
FM detection output voltage	V _{O1}	Vi = 100dB μ , $\Delta f = \pm 25\text{kHz}$	440	550	670	mVrms
FM detection output distortion ratio	THD	Vi = 100dB μ , $\Delta f = \pm 25\text{kHz}$	0	0.4	1.0	%
AM rejection	AMR	Vi = 100dB μ , $\frac{\text{FM} : \Delta f = \pm 25\text{kHz}}{\text{AM} : 30\%}$	40	60	80	dB
AF amplifier voltage gain	G _{AF}	Vi = 100mVrms, f = 400Hz	18	20	22	dB
AF maximum output voltage	V _{O6 max}	Output level for AF amplifier output distortion at 10%	2.0	2.8	3.6	Vrms
AF electronic attenuator range	ATT	Vi = 200mVrms, f = 400Hz	70	80	100	dB
[Video]						
Black enhancement threshold	B _{STH}	APL variable	40	50	60	IRE
Maximum black enhancement gain	BS max	APL variable	-35	-27	-20	IRE
Soft video tone variable range	Δ Soft	f = 2MHz, 100mVp-p video tone VR: 4V \rightarrow 0V	-6	-4	-2	dB
Sharp video tone variable range	Δ Sharp	f = 2MHz, 100mVp-p video tone VR: 4V \rightarrow 9V, contrast VR: 6V	7	10	13	dB
Video voltage gain audio-visual Switch 9V	GV9V	f = 100kHz, 100mVp-p, contrast VR: 9V, video tone VR: 4V	15	18	21	dB
Video voltage gain audio-visual Switch 0V	GV0V	f = 100kHz, 100mVp-p, contrast VR: 0V, video tone VR: 4V	15	18	21	dB
Contrast control center	C _{CEN}	f = 100kHz, 100mVp-p, contrast VR: 6V	0.4	0.48	0.57	Vp-p
Contrast variable control range	Δ C _V	Contrast VR: 3V \rightarrow 9V	18	20	22	dB
Bright control	B R _H	Bright VR: 2V	5.5	6.5	7.5	V
	B R _{CEN}	Bright VR: 4.5V	3.1	3.6	4.1	V
	B R _L	Bright VR: 7.5V		0.3	1.2	V
D.L. off frequency characteristics	f _v 9V	Contrast VR: 6V, video tone VR: 4V, 3dB down	7	9		MHz
D.L. on frequency characteristics	f _v 0V	Contrast VR: 6V, video tone VR: 4V, 3dB down	2.5	3	4	MHz
DC transmission	R _{DC}	Input: stair step signal, 500mVp-p	100	103	106	%
Delay line delay	T _{DL}	Input: white 100%	290	340	390	ns
[Chroma]						
ACC amplitude characteristics	A _{CC1}	+6dB	-3	0	+3	dB
	A _{CC2}	-20dB	-7	0	+2	dB
ACC phase characteristics	A _{CCP1}	+6dB	-3	0	+3	$^{\circ}$ C
	A _{CCP2}	-20dB	-7	0	+7	$^{\circ}$ C
Killer operation point	E _K		-35	-28	-21	dB
Color control color residual	E _{C min}	Color VR: 0V, contrast VR: 9V			50	mVp-p
Color control center	E _{C CEN}	Color VR: 4.5V, contrast VR: 6V	1.2	1.8	2.4	Vp-p
Maximum demodulation output	E _{C max}	Color VR: 9V, contrast VR: 9V	3.2	4.0	4.8	Vp-p
Color contrast variable range	Δ C _C	Color VR: B - Y = 2.5Vp-p, contrast VR: 3V \rightarrow 9V	17.5	19.5	21.5	dB
Tint control center	T _{CEN}	Tint VR: 4.5V, color VR: 4.5V, contrast VR: 6V	0	12	24	$^{\circ}$ C
Tint variable range	Δ T	Tint VR: 0V \leftarrow 4.5V \rightarrow 8V, color VR: 4.5V, contrast VR: 6V	± 40	± 55	± 70	$^{\circ}$ C
APC pull-in range	Δf_{APC}		± 300	± 500		Hz

Continued on next page.

LA7674

Continued from preceding page.

Parameter	Symbol	Conditions	Ratings			Unit
			min	typ	max	
Demodulator output ratio	R/B	Monochrome signal, contrast VR: 6V, color VR: B – Y = 1Vpo	0.81	0.90	0.98	
	G/B	Monochrome signal, contrast VR: 6V, color VR: B – Y = 1Vpo	0.24	0.30	0.38	
Demodulator phase angle	RB	Monochrome signal, contrast VR: 6V, color VR: B – Y = 1Vpo	97	105	113	DEG
	GB	Monochrome signal, contrast VR: 6V, color VR: B – Y = 1Vpo	-130	-120	-110	DEG
Demodulator output DC voltage	V _{C-Y}	Burst signal only, color VR: 0V	4.7	5.2	5.7	V
Demodulator output DC offset voltage	ΔV _{C-Y}	Burst signal only, color VR: 0V	-200	0	+200	mV
Demodulator output residual carrier	E car	Quiescent, killer off, color VR: 0V			0.05	Vp-p
[OSD]						
Blanking pulse threshold level	TH _{BL}	C – IN: color bar, B – IN: variable	0.5	0.8	1.1	V
- Y out DC voltage (OSD mode)	V _{-Y}	B-IN : 1.5V	2.5	2.8	3.1	V
RGB – in threshold level	TH _R	R – IN: variable, B – IN: 1.5V	1.9	2.2	2.5	V
	TH _G	G – IN: variable, B – IN: 1.5V				
	TH _B	B – IN, variable				
RGB – Y out DC voltage (3 V)	V _{R3V}	R, G, B – IN :3V	5.2	5.5	5.8	V
	V _{G3V}					
	V _{B3V}					
RGB – Y out DC voltage (4 V)	V _{R4V}	R, G, B – IN : 4V	5.7	6.0	6.3	V
	V _{G4V}					
	V _{B4V}					
RGB – Y out DC voltage (5 V)	V _{R5V}	R, G, B – IN : 5V	6.2	6.5	6.8	V
	V _{G5V}					
	V _{B5V}					
[Deflection]						
Synchronization separator input DC level	V _{SDC}		6.0	6.3	6.6	V
Vertical free-running period	T _{V free}		262	262.5	263	H
Maximum vertical synchronization period	T _{V max}	Input: horizontal synchronization signal only	296.5	297	297.5	H
Minimum vertical synchronization period	T _{V min}		224.5	225	225.5	H
Vertical blanking pulse width	P _{W VBL}		20.25	20.5	20.75	H
Vertical blanking pulse wave Height value	P _{H VBL}		7.0	7.5		V
Vertical output pulse width	P _{W VOUT}		8.25	8.5	8.75	H
Vertical output voltage	V _{OUT H}		5.7	6	6.3	V
	V _{OUT M}		4.2	4.5	4.8	V
	V _{OUT L}			0.1	0.3	V
Vertical external trigger load resistance	R _{TR}		2.7	3.6		kΩ
Vertical automatic synchronization stop voltage	V _{SAS}			1.9	2.4	V
Vertical output pulse start V _{CC} voltage	S _{VV}			3	4	V
Horizontal free-running frequency deviation	Δf _H	Deviation from 15.734kHz	-90	+30	+150	Hz
Horizontal pull-in range	f _{H PULL}	Deviation from 15.734kHz	±400	±550		Hz
Horizontal output pulse width	P _{WH OUT}		21.8	23.8	25.8	μs
Horizontal output pulse phase	H _{PF}		15	17	19	μs
	H _{PCEN}		3.4	4.4	5.4	μs
	H _{PR}		0	3	6	μs
Horizontal output pulse start V _{CC} voltage	S _{HV}			4.5	5.3	V
AFC II FBP peak voltage	F _{BPH}		4.1	4.6	5.1	V
Burst gate pulse delay time	T _{d BGP}		0.2	0.6	1.2	μs
Burst gate pulse width	P _{W BGP}		2.7	3.7	4.7	μs
VCR SW input voltage	V _{CR}			1.3	2.0	V
X-ray protector circuit operation input voltage	V _{HD}		0.64	0.74	0.84	V
Horizontal synchronization detection Threshold level	H _{coin}		4.2	4.5	4.8	V
Horizontal output current	H _{OUT}	I _{CC} = 13mA	3.8	4.7	5.5	mA

Sample Application Circuit

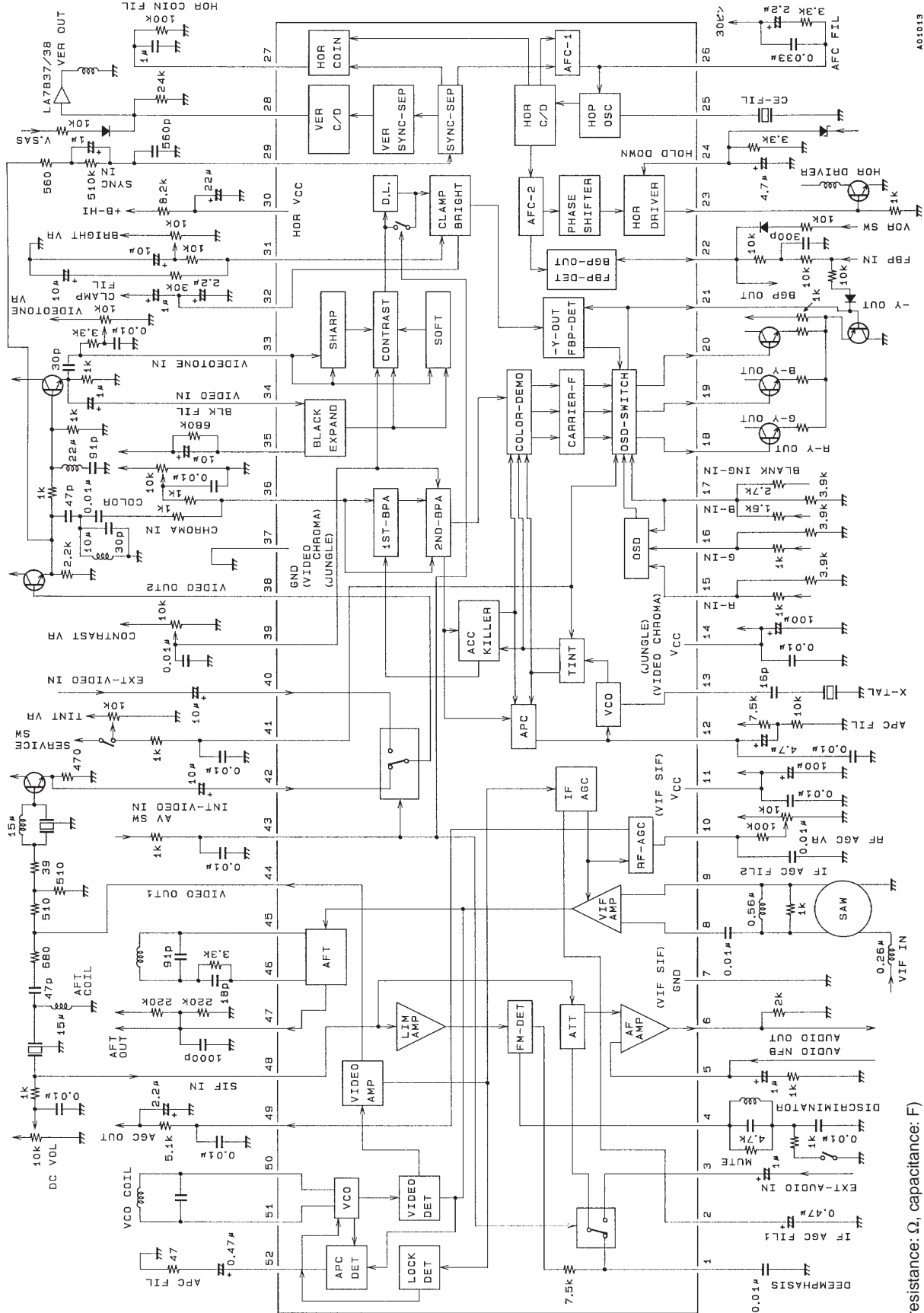

AO1013

Unit (resistance: Ω, capacitance: F)

- Specifications of any and all SANYO products described or contained herein stipulate the performance, characteristics, and functions of the described products in the independent state, and are not guarantees of the performance, characteristics, and functions of the described products as mounted in the customer's products or equipment. To verify symptoms and states that cannot be evaluated in an independent device, the customer should always evaluate and test devices mounted in the customer's products or equipment.
- SANYO Electric Co., Ltd. strives to supply high-quality high-reliability products. However, any and all semiconductor products fail with some probability. It is possible that these probabilistic failures could give rise to accidents or events that could endanger human lives, that could give rise to smoke or fire, or that could cause damage to other property. When designing equipment, adopt safety measures so that these kinds of accidents or events cannot occur. Such measures include but are not limited to protective circuits and error prevention circuits for safe design, redundant design, and structural design.
- In the event that any or all SANYO products (including technical data, services) described or contained herein are controlled under any of applicable local export control laws and regulations, such products must not be exported without obtaining the export license from the authorities concerned in accordance with the above law.
- No part of this publication may be reproduced or transmitted in any form or by any means, electronic or mechanical, including photocopying and recording, or any information storage or retrieval system, or otherwise, without the prior written permission of SANYO Electric Co., Ltd.
- Any and all information described or contained herein are subject to change without notice due to product/technology improvement, etc. When designing equipment, refer to the "Delivery Specification" for the SANYO product that you intend to use.
- Information (including circuit diagrams and circuit parameters) herein is for example only; it is not guaranteed for volume production. SANYO believes information herein is accurate and reliable, but no guarantees are made or implied regarding its use or any infringements of intellectual property rights or other rights of third parties.

This catalog provides information as of July, 1999. Specifications and information herein are subject to change without notice.