



LA7851

CRT Display Synchronization Deflection Circuit

Overview

The LA7851 is a sync deflection circuit IC dedicated to CRT display use. It can be connected to the LA7832, 7833 (for vertical output use) to form a sync deflection circuit that meets every requirement for CRT display use.

So far, ICs for color TV use have been applied to the sync deflection circuit for CRT display use and general-purpose ICs such as one-shot multivibrator, inverter and a lot of transistors have been used to form the peripherals such as sync input interface, horizontal phase shifter. The LA7851 contains these peripherals on chip, has a wide vertical pull-in range of 20Hz, and adopts a stable circuit for horizontal oscillation from 15kHz to 100kHz aiming at improving the characteristics required for CRT display use.

Features

- The vertical pull-in range 20Hz permits non-adjusting at vertical sync 50Hz/60Hz.
- The horizontal oscillation frequency can be adjusted stably from 15kHz to 100kHz.
- The horizontal display can be shifted right/left.
- The horizontal/vertical sync input can be used intact regardless of the difference in pulse polarity and pulse width.
- The AFC feedback sawtooth wave can be obtained by simply applying a flyback pulse to the IC as a trigger pulse.
- Any duty of the horizontal pulse can be set.
- Good linearity because DC bias at vertical output stage is subject to sampling control within retrace time.

On-Chip Functions

[Horizontal Block]

- AFC
- Horizontal OSC
- X-ray protector
- Horizontal phase shift
- AFC sawtooth wave generator
- Horizontal pulse duty setting

[Vertical Block]

- Vertical OSC
- Vertical sawtooth wave generator
- Sampling type DC voltage control

Package Dimensions

unit:mm

3021C-DIP20

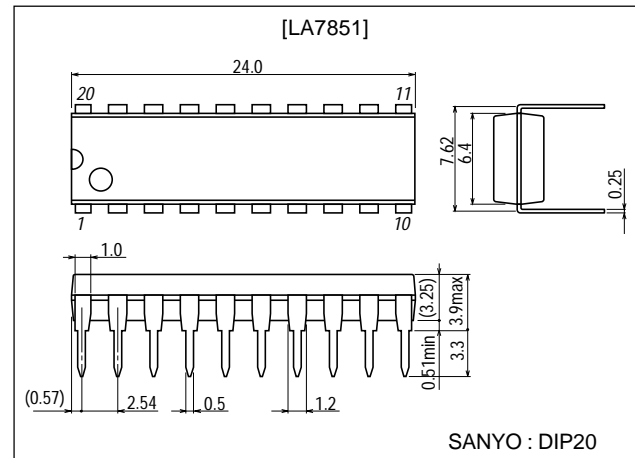

■ Any and all SANYO products described or contained herein do not have specifications that can handle applications that require extremely high levels of reliability, such as life-support systems, aircraft's control systems, or other applications whose failure can be reasonably expected to result in serious physical and/or material damage. Consult with your SANYO representative nearest you before using any SANYO products described or contained herein in such applications.

■ SANYO assumes no responsibility for equipment failures that result from using products at values that exceed, even momentarily, rated values (such as maximum ratings, operating condition ranges, or other parameters) listed in products specifications of any and all SANYO products described or contained herein.

SANYO Electric Co., Ltd. Semiconductor Company

TOKYO OFFICE Tokyo Bldg., 1-10, 1 Chome, Ueno, Taito-ku, TOKYO, 110-8534 JAPAN

O2500TN (KT)/N218TA/4015MW/6114KI, TS No.1775-1/4

LA7851

Specifications

Maximum Ratings at Ta = 25°C

Parameter	Symbol	Conditions	Ratings	Unit
Maximum supply voltage	V ₁₀ , V ₂₀ max		14	V
Allowable power dissipation	Pd max	Ta≤65°C	780	mW
Operating temperature	Topr		-20 to +85	°C
Storage temperature	Tstg		-55 to +125	°C

Operating Conditions at Ta = 25°C

Parameter	Symbol	Conditions	Ratings	Unit
Recommended supply voltage	V ₁₀ , V ₂₀		12.0	V
Operating voltage range	V ₁₀ , V ₂₀ op		9 to 13.5	V
Recommended vertical pulse input peak value	V _{PULSE}		5.0	Vp-p
Operating vertical pulse input peak value range	V _{PULSE}		2.0 to 6.0	Vp-p
Recommended horizontal pulse input peak value	H _{PULSE}		5.0	Vp-p
Operating horizontal pulse input peak value range	H _{PULSE}		2.0 to 6.0	Vp-p

Operating Characteristics at Ta = 25°C, V₁₁, V₂₂=12V

Parameter	Symbol	Conditions	Ratings			Unit
			min	typ	max	
V _{CC10} current drain	I ₁₀		12		30	mA
V _{CC20} current drain	I ₂₀		5		12	mA
Vertical frequency pull-in range	V _{P IN}	Vertical sync 60Hz	21.0		23.0	Hz
Vertical free-running frequency	f _V	f _V center 55Hz	50		60	Hz
Increased/reduced voltage characteristic of vertical frequency	Δf _V	V ₂₂ =12±1V, 55Hz at 12V	-0.1		+0.1	Hz
Midpoint control threshold level			3.8		4.4	V
Vertical OSC start voltage	f _{v, st}				4.0	V
Temperature characteristic of vertical frequency		Ta=-10 to +60°C	-0.028		+0.028	Hz/°C
Vertical driver amplification factor	G _V		12		18	dB
Horizontal AFC DC loop gain	I _{AFC}		±0.85		±1.6	mA
Horizontal free-running frequency	f _H	f _H center 15.734kHz	-750		+750	Hz
Horizontal OSC start voltage	f _{H, st}				4.0	V
Increased/reduced voltage characteristic of horizontal frequency	Δf _{H, V}	V ₁₁ =12±1V, 15.734kHz at 12V	-50		+50	Hz
Horizontal OSC warm-up drift	Δf _H	5s. to 30min. after application of power	-50		+50	Hz
Temperature characteristic of horizontal frequency		Ta=-10 to +60°C	-2.9		+2.9	Hz/°C
Horizontal output drive current	I ₁₂		6.0		12.0	mA
Increased/reduced voltage characteristic of phase shifter delay time		V ₁₀ =12±1V	-0.5		+0.5	%/V
Temperature characteristic of phase shifter delay time		Ta=-10 to +60°C	-0.1		+0.1	%/°C
Increased/reduced voltage characteristic of phase shifter delay time		V ₁₀ =12±1V	-1.0		+1.0	%/V
Temperature characteristic of phase shifter pulse width		Ta=-10 to +60°C	-0.13		+0.13	%/°C
AFC phase comparison center time		15.734kHz after F.B.P. input	9.9		11.5	μs
Increased/reduced voltage characteristic of AFC phase comparison center time		V ₁₀ =12±1V	-1.5		+1.5	%/V
Temperature characteristic of AFC phase comparison center time		Ta=-10 to +60°C	-0.2		+0.2	%/°C
Comparison waveform generating input operation voltage	V ₄		0.6		0.9	V
pin 13 voltage at hold-down operation start	V ₁₃		0.5		0.8	V

LA7851

Equivalent Circuit Block Diagram

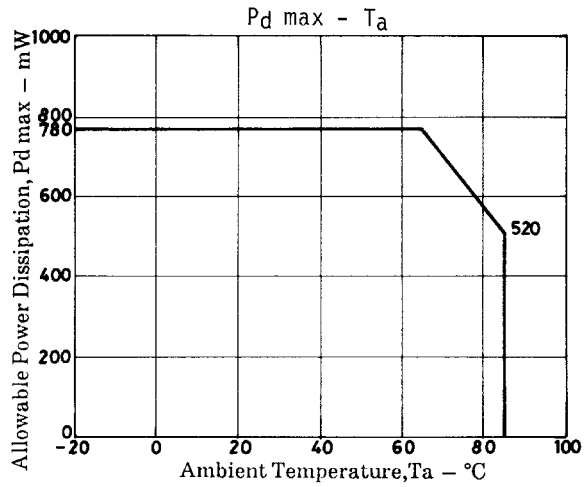
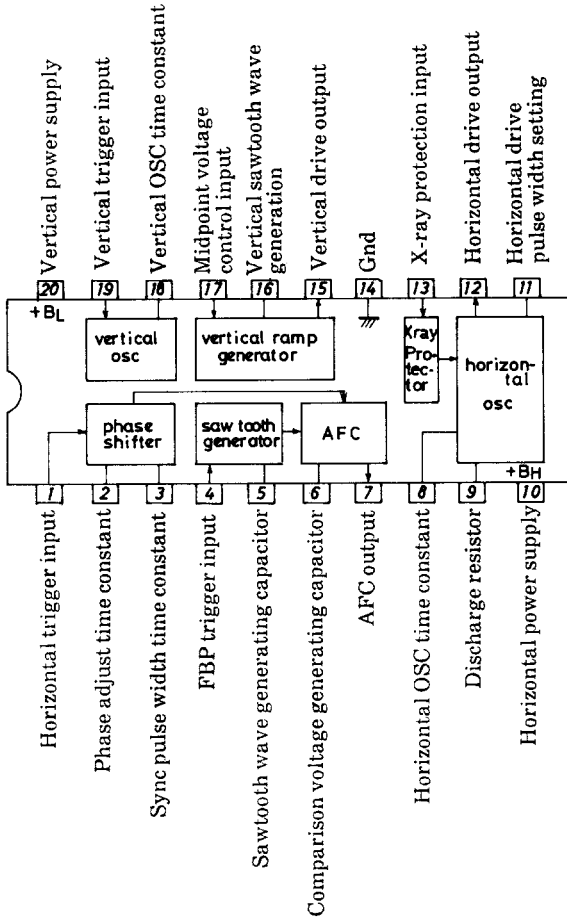

Sample Application Circuit : 14" Color Monitor/ $f_V=60\text{Hz}$, $f_H=15.734\text{kHz}$

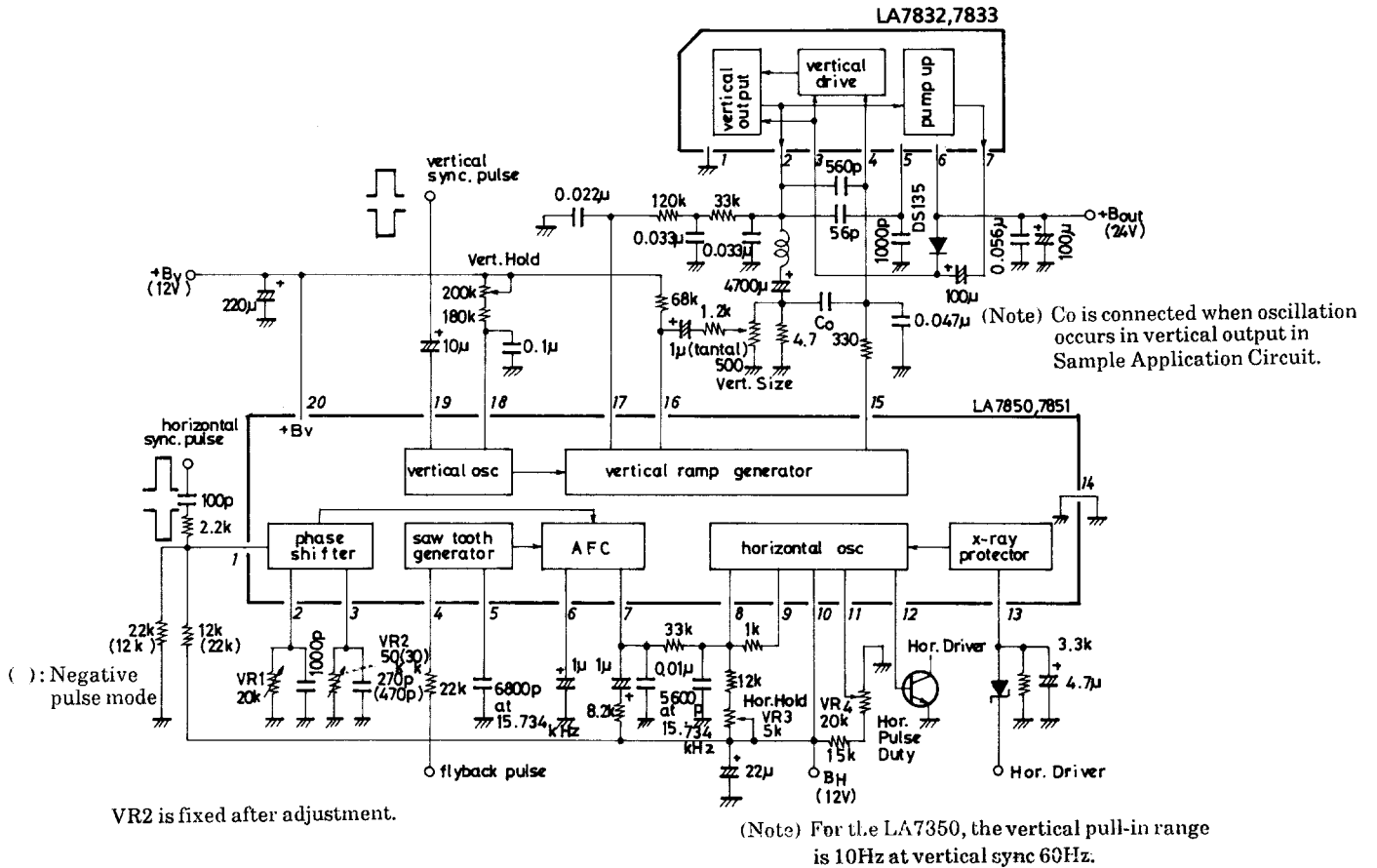

Unit (resistance:Ω, capacitance:F)

- Specifications of any and all SANYO products described or contained herein stipulate the performance, characteristics, and functions of the described products in the independent state, and are not guarantees of the performance, characteristics, and functions of the described products as mounted in the customer's products or equipment. To verify symptoms and states that cannot be evaluated in an independent device, the customer should always evaluate and test devices mounted in the customer's products or equipment.
- SANYO Electric Co., Ltd. strives to supply high-quality high-reliability products. However, any and all semiconductor products fail with some probability. It is possible that these probabilistic failures could give rise to accidents or events that could endanger human lives, that could give rise to smoke or fire, or that could cause damage to other property. When designing equipment, adopt safety measures so that these kinds of accidents or events cannot occur. Such measures include but are not limited to protective circuits and error prevention circuits for safe design, redundant design, and structural design.
- In the event that any or all SANYO products(including technical data, services) described or contained herein are controlled under any of applicable local export control laws and regulations, such products must not be exported without obtaining the export license from the authorities concerned in accordance with the above law.
- No part of this publication may be reproduced or transmitted in any form or by any means, electronic or mechanical, including photocopying and recording, or any information storage or retrieval system, or otherwise, without the prior written permission of SANYO Electric Co., Ltd.
- Any and all information described or contained herein are subject to change without notice due to product/technology improvement, etc. When designing equipment, refer to the "Delivery Specification" for the SANYO product that you intend to use.
- Information (including circuit diagrams and circuit parameters) herein is for example only ; it is not guaranteed for volume production. SANYO believes information herein is accurate and reliable, but no guarantees are made or implied regarding its use or any infringements of intellectual property rights or other rights of third parties.

This catalog provides information as of October, 2000. Specifications and information herein are subject to change without notice.