

General Description

LA8506 is a current mode, step-down DC-DC converter that is designed to meet 3A output current, and utilizes PWM control scheme that switches with 500KHz fixed frequency.

The input voltage range of LA8506 is from 8V to 40V, and available in adjustable output voltage from 1.222V to 24V. The supply current is only 1mA during operation and under 30uA in shutdown.

This device provides an enable function that can be controlled by external logic signal. It also provides excellent regulation during line or load transient. Other features of soft-start current limit, thermal shutdown protection, and short circuit protection are also included. Due to the low $R_{DS(ON)}$ of the internal power MOSFET, this device provides high efficiency step-down applications. The package is available in standard ESOP-8.

Features

- | Adjustable Output from 1.222V to 24V
- | 8V to 40V Input Voltage Range
- | Continuous 3A Output Capability
- | 500KHz Oscillation Frequency
- | 1.222V +/- 1.5% Reference Voltage
- | 30uA Low Shutdown Current
- | 1mA Low Supply Current
- | Current Mode for Excellent Response
- | Support Low ESR Output Ceramic Capacitors
- | Internal Current Limit
- | Short Circuit Protection
- | Thermal Shutdown Protection
- | ESOP-8 Package
- | Meet RoHS Standard

Applications

- | Broadband Communication Device
- | LCD TV / Monitor
- | Storage Device
- | Automotive Electronics

Ordering Information

LA8506 1 2 3 4

- 1 (Package Type) => P: ESOP
- 2 (Number of Pins) => G: 8pin
- 3 (Output Voltage) => Blank: Adjustable
- 4 (Special Feature) => Blank: N/A

Available Part Number

LA8506PG

Marking Information

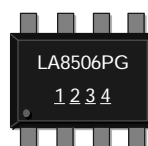

1 2 (Date Code)

For date code rule, please contact our sales representative directly

3 4 (Internal Code)

Typical Application

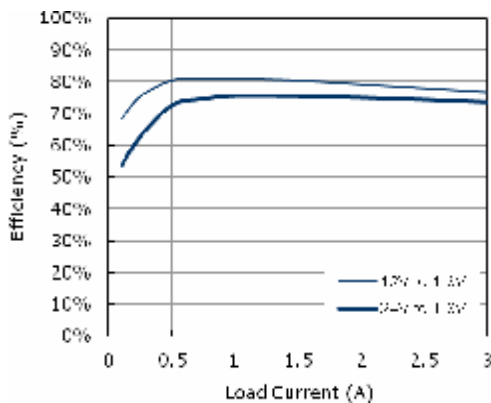
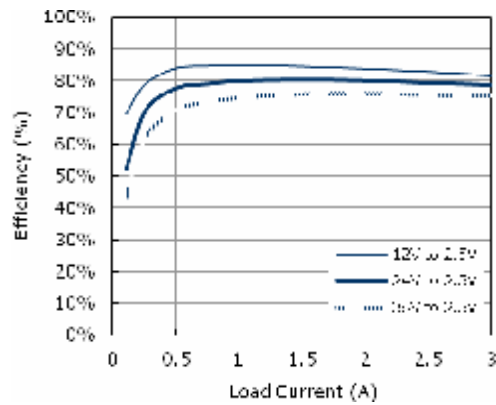
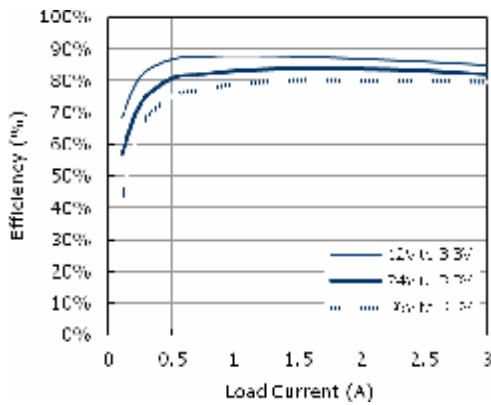
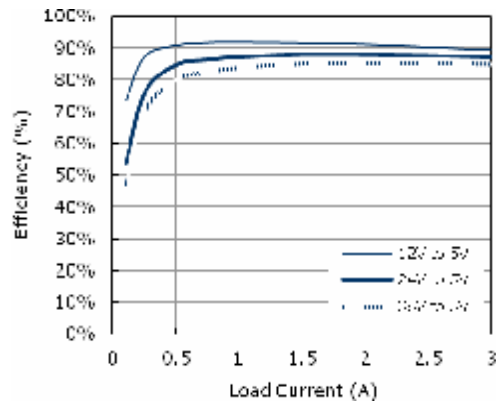
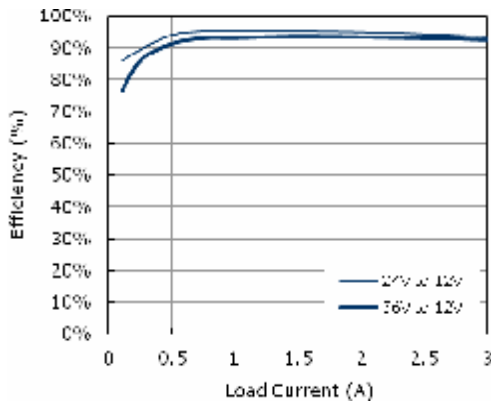
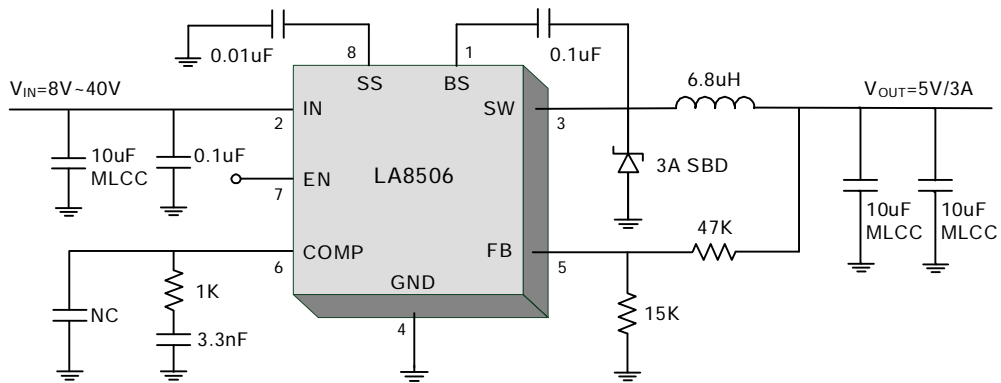

Functional Block Diagram

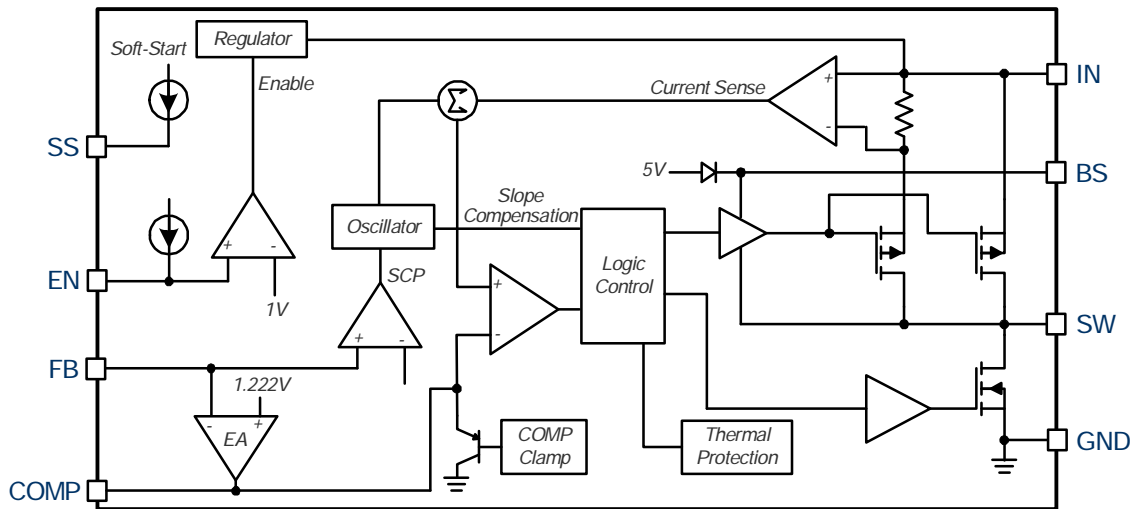

Pin Configurations

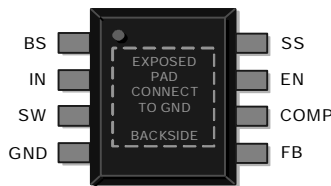

Pin No.	Name	Description
1	BS	Bootstrap. This pin provides power for the high side switch. Connect 0.1uF from BS to SW to power the switch.
2	IN	Power Input. Connect 10uF MLCC or greater and 0.1uF bypass capacitor from this pin to ground.
3	SW	Power Switch Output. This pin is the switching node that supplies power to the output. Connect an L-C filter from SW to the output load.
4	GND	Ground. Connect this pin to the circuit ground.
5	FB	Feedback. This pin senses the feedback to regulate the output voltage. Connect FB to a voltage divider to set the output voltage.
6	COMP	Compensation Node. Connect a series R-C network from COMP to GND to compensate the regulation control loop. In some cases, an additional capacitor from COMP to GND is required.
7	EN	Enable Input. EN is a digital input that turns the regulator on or off. Drive EN HIGH to turn on the regulator, drive it LOW to turn it off. For automatic start-up, leave EN unconnected.
8	SS	Soft-Start Control Input. Connect a capacitor from SS to GND to set the Soft-Start period. Leave SS unconnected if this function is not used.

Absolute Maximum Ratings

Parameter	Rating
Input Voltage	42V
SW Voltage Range	-1V ~ $V_{IN}+1V$
BS Voltage Range	$V_{SW}-0.3V$ ~ $V_{SW}+6V$
SS/FB / EN / COMP Voltage Range	-0.3V ~ 6V
Storage Temperature Range	-65°C ~ 150°C
Junction Temperature	150°C
Lead Soldering Temperature (10 sec)	260°C

These are stress ratings only and functional operation is not implied. Exposure to absolute maximum ratings for prolonged time periods may affect device reliability. All voltages are with respect to ground.

Recommended Operating Conditions

Parameter	Rating
Input Voltage Range	8V ~ 40V
Ambient Temperature Range	-40°C ~ 85°C
Junction Temperature Range	-40°C ~ 125°C

These are conditions under which the device functions but the specifications might not be guaranteed. For guaranteed specifications and test conditions, please see the *Electrical Specifications*.

Package Information

Parameter	Package	Symbol	Rating
Thermal Resistance (Junction to Case)	ESOP-8	θ_{JC}	10 °C/W
Thermal Resistance (Junction to Ambient)		θ_{JA}	50 °C/W

Electrical Specifications

$V_{IN}=12V$, $T_A=25^{\circ}C$, unless otherwise noted.

Parameter	Test Condition	Min.	Typ.	Max.	Units
Feedback Voltage		1.204	1.222	1.240	V
Oscillation Frequency		400	500	600	KHz
Short Circuit Frequency	$V_{FB}=0V$		100		KHz
Maximum Duty Cycle	$V_{FB}=1V$		85		%
Minimum ON time				125	ns
High Side MOSFET $R_{DS(ON)}$	$I=1A$		100		$m\Omega$
Low Side MOSFET $R_{DS(ON)}$			10		Ω
Current Limit			4.3		A
Error Amp. Voltage Gain, A_{VEA}			400		V/V
Error Amp. Transconductance, G_{EA}			500		$\mu A/V$
Current Sense Transconductance, G_{CS}			3.3		A/V
Supply Current	$V_{FB}=1.5V$		1	1.2	mA
Shutdown Current	$V_{EN}=0V$		30	60	μA
EN Threshold Voltage		0.85	1	1.15	V
EN Pull Up Current	$V_{EN}=0V$		5.5		μA
Soft Start Bias Current			4		μA
Over Temperature Shutdown			150		$^{\circ}C$
Over Temperature Shutdown Hysteresis			25		$^{\circ}C$

Typical Performance Characteristics

$V_{IN}=12V, T_A=25^{\circ}C$, unless otherwise noted.

Feedback Voltage vs. Input Voltage

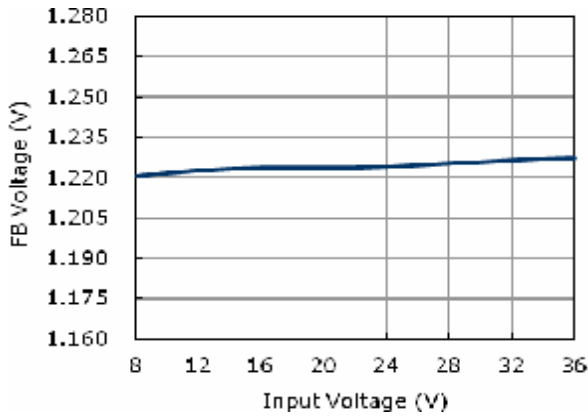

Feedback Voltage vs. Temperature

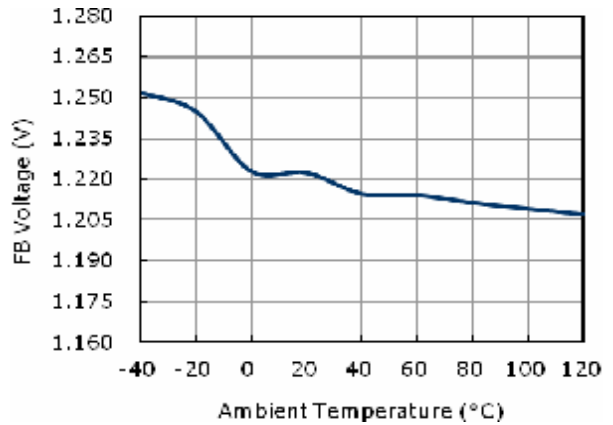

Frequency vs. Input Voltage

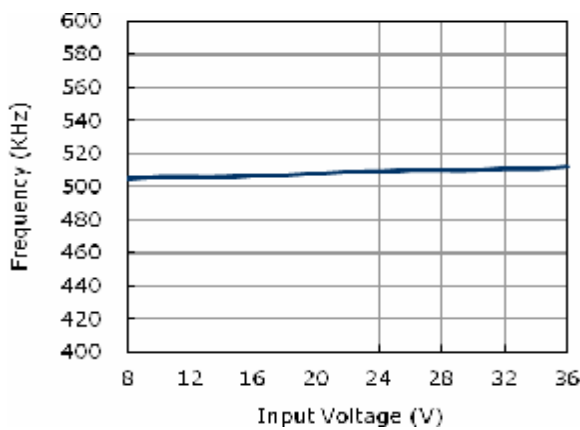

Frequency vs. Temperature

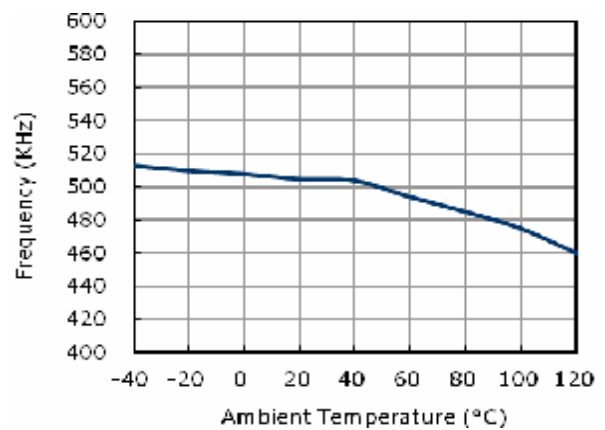

Short Circuit Frequency vs. Input Voltage

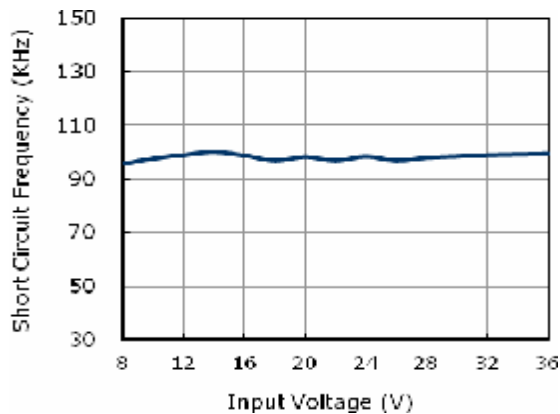

Short Circuit Frequency vs. Temperature

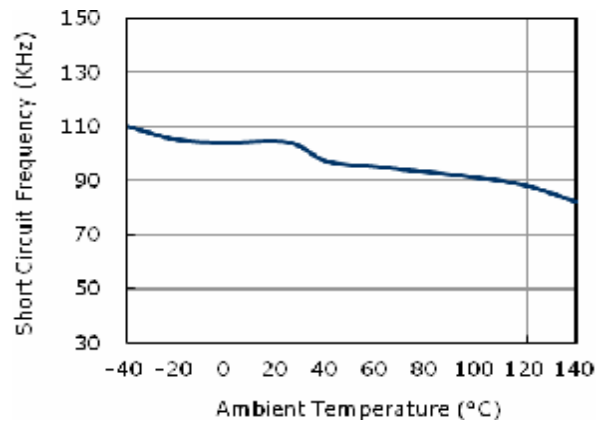

Supply Current vs. Input Voltage

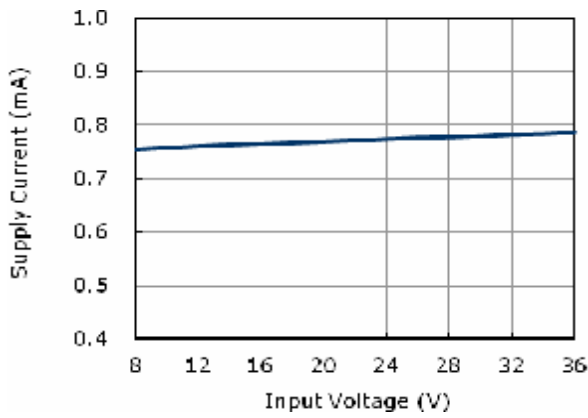

Shutdown Current vs. Temperature

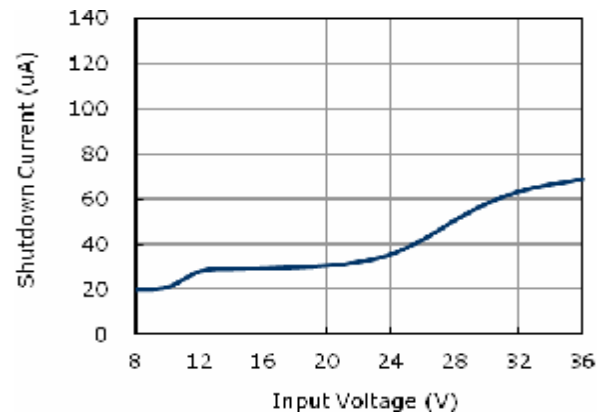

Line Regulation

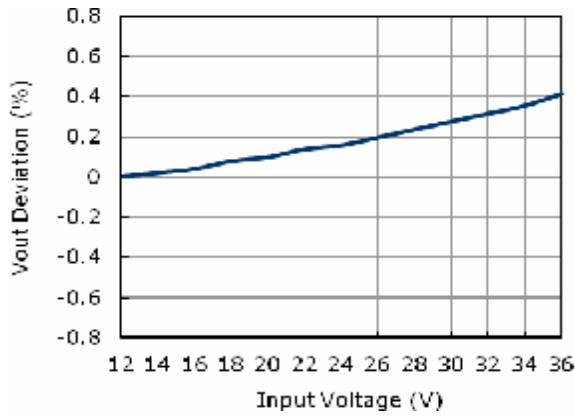

Load Regulation

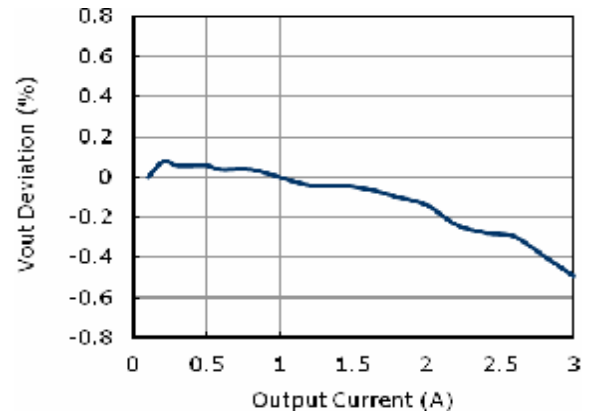

EN Bias Current vs. Input Voltage

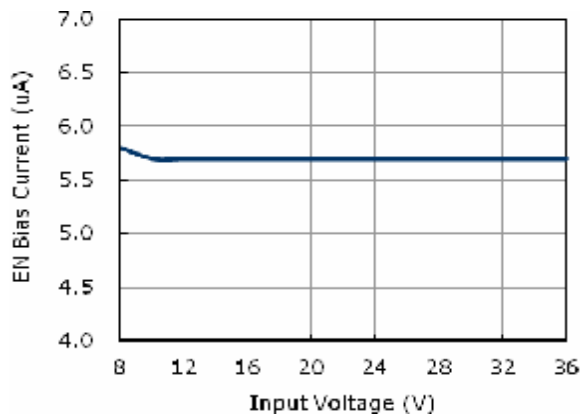

Start-up Waveform

$V_{IN}=12V$ $V_{OUT}=5V$, $I_{LOAD}=0.1A$

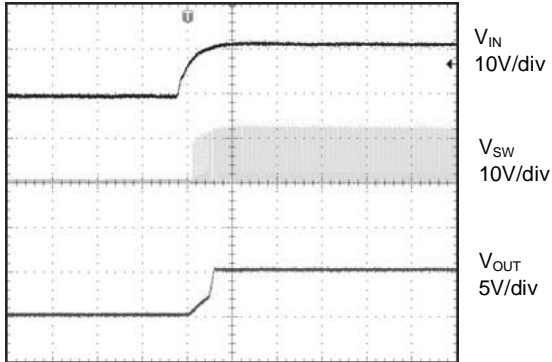

Time Base: 1ms/div

Shutdown Waveform

$V_{IN}=12V$ $V_{OUT}=5V$, $I_{LOAD}=0.1A$

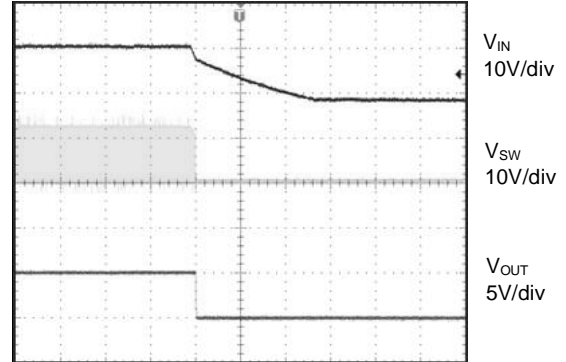

Time Base: 40ms/div

Output Voltage Ripple - CCM

$V_{IN}=12V$ $V_{OUT}=5V$, $I_{LOAD}=3A$

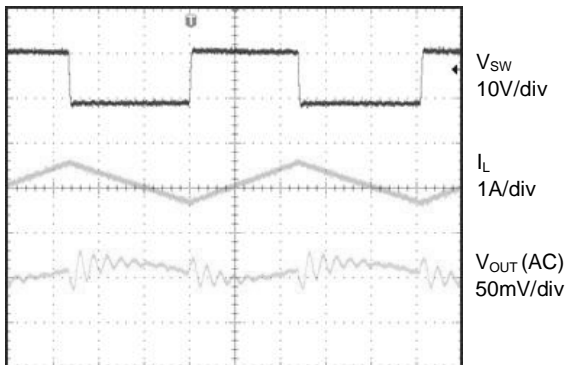

Time Base: 400ns/div

Application Information

Output Voltage Programming

LA8506 develops a band-gap between the feedback pin and ground pin. Therefore, the output voltage can be formed by R1 and R2. Use 1% metal film resistors for the lowest temperature coefficient and the best stability. Select lower resistor value to minimize noise pickup in the sensitive feedback pin, or higher resistor value to improve efficiency.

The output voltage is given by the following formula:

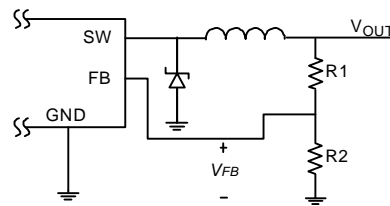

$$V_{OUT} = V_{FB} \times (1 + R1 / R2) ; \text{ where } V_{FB} = 1.222V$$

Short Circuit Protection

When the output is shorted to ground, the protection circuit will be triggered and force the oscillation frequency down to approximately 100KHz. The oscillation frequency will return to 500KHz once the output voltage or the feedback voltage rises above 0V.

Soft-Start

This device includes soft-start function with an external capacitor. It is useful to reduce supply inrush current, and prevent output voltage from overshooting during start-up. The soft start time can be calculated by the following formula:

$$T_{SS} = \frac{C_{SS} \times 0.2V}{4\mu A}$$

Delay Start-up

The following circuit uses the EN to provide a time delay between the input voltage is applied and the output voltage comes up. As the instant of the input voltage rises, the charging of capacitor C_{DELAY} pulls EN low, keeping the device off. Once the capacitor voltage rises above the EN threshold voltage, the device will start to operate. The start-up delay time can be calculated by the following formula:

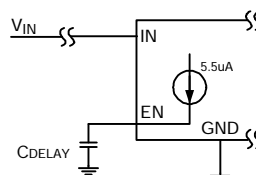

$$T_{\text{DELAY}} = \frac{C_{\text{DELAY}} \times V_{\text{EN(th)}}}{5.5\mu\text{A}}$$

Where $V_{\text{EN(th)}}$ is the EN threshold voltage that is approximately 1V.

This feature is useful in situations where the input power source is limited in the amount of current it can deliver. It allows the input voltage to rise to a higher voltage before the device starts operating.

Snubber Circuit

The simple RC snubber is used for voltage transient and ringing suppression. The high frequency ringing and voltage overshooting at the SW pin is caused by fast switching transition and resonating circuit parasitical elements in the power circuit. It maybe generates EMI and interferes with circuit performance. Reserve a snubber circuit in the PC board is preferred to damp the ringing due to the parasitical capacitors and inductors of layout. The following circuit is a simple RC snubber:

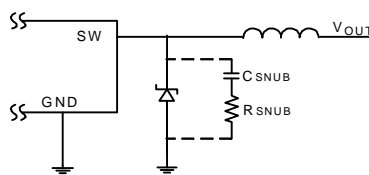

Choose the value of RC network by the following procedure:

- (1) Measure the voltage ringing frequency (f_R) of the SW pin.
- (2) Find a small capacitor and place it across the SW pin and the GND pin to damp the ringing frequency by half.
- (3) The parasitical capacitance (C_{PAR}) at the SW pin is 1/3 the value of the added capacitance above. The parasitical inductance (L_{PAR}) at the SW pin is:

$$L_{\text{PAR}} = \frac{1}{(2\pi f_R)^2 \times C_{\text{PAR}}}$$

- (4) Select the value of C_{SNUB} that should be more than 2~4 times the value of C_{PAR} but must be small enough so that the power dissipation of R_{SNUB} is kept to a minimum.

The power rating of R_{SNUB} can be calculated by following formula:

$$P_{\text{RSNUB}} = C_{\text{SNUB}} \times V_{\text{IN}}^2 \times f_s$$

- (5) Calculate the value of R_{SNUB} by the following formula and adjust the value to meet the expectative peak voltage.

$$R_{\text{SNUB}} = 2\pi \times f_R \times L_{\text{PAR}}$$

Thermal Considerations

Thermal protection limits total power dissipation in this device. When the junction temperature reaches approximately 150°C, the thermal sensor signals the shutdown logic turning off this device. The thermal sensor will turn this device on again after the IC's junction temperature cools by approximately 25°C. For continuous operation, do not exceed the maximum operation junction temperature 125°C.

The power dissipation across this device can be calculated by the following formula:

$$P_D = I_{LOAD}^2 \times R_{DS(ON)} \times \frac{V_{OUT}}{V_{IN}} + \frac{1}{2} \times V_{IN} \times I_{OUT} \times (t_r + t_f) \times f_s + Q_g \times V_{GS} \times f_s + V_{IN} \times I_s$$

Where f_s is the 500KHz switching frequency, (t_r+t_f) is the switching time that is approximately 20ns, Q_g is the power MOSFET gate charge that is approximately 15nC, V_{GS} is the gate voltage of the power MOSFET that is approximately 5V, and I_s is the 1mA supply current.

The maximum power dissipation of this device depends on the thermal resistance of the IC package and PCB layout, the temperature difference between the die junction and ambient air, and the rate of airflow. The maximum power dissipation can be calculated by the following formula:

$$P_{D(MAX)} = \frac{(T_J - T_A)}{\theta_{JA}}$$

Where $T_J - T_A$ is the temperature difference between the die junction and surrounding environment, θ_{JA} is the thermal resistance from the junction to the surrounding environment.

The value of junction to case thermal resistance θ_{JC} is also popular to users. This thermal parameter is convenient for users to estimate the internal junction operated temperature of packages while IC operating. The operated junction temperature can be calculated by the following formula:

$$T_J = T_C + P_D \times \theta_{JC}$$

T_C is the package case temperature measured by thermal sensor. Therefore it's easy to estimate the junction temperature by any condition.

There are many factors affect the thermal resistance. Some of these factors include trace width, copper thickness, total PCB copper area, and etc. For the best thermal performance, wide copper traces and generous amounts of PCB copper should be used in the board layout. If further improve thermal characteristics are needed, double sided and multi-layer PCB with large copper areas and airflow will be recommended.

Layout Considerations

PC board layout is very important, especially for switching regulators of high frequencies and large peak currents. A good layout minimizes EMI on the feedback path and provides best efficiency.

The following layout guides should be used to ensure proper operation of this device.

- (1) The power charge path that consists of the IN trace, the SW trace, the external inductor and the GND trace should be kept wide and as short as possible.
- (2) The power discharge path that consists of the SW trace, the external inductor, the rectifier diode and the GND trace should be kept wide and as short as possible.
- (3) The feedback path of voltage divider should be close to the FB pin and keep noisy traces away; also keep them separate using grounded copper.
- (4) The input capacitors should be close to the regulator and rectifier diode.
- (5) The output capacitors should be close to the load.

Component Selection

Inductor Selection

The conduction mode of power stage depends on input voltage, output voltage, output current, and the value of the inductor. Select an inductor to maintain this device operating in continuous conduction mode (CCM). The minimum value of inductor can be determined by the following procedure.

(1) Calculate the minimum duty ratio:

$$D_{(MIN)} = \frac{V_{OUT} + I_{LOAD} \times DCR + V_F}{V_{IN(MAX)} - I_{LOAD} \times R_{DS(ON)} + V_F} = \frac{T_{ON}}{T_S}$$

Where DCR is the DC resistance of the inductor, V_F is the forward voltage of the rectifier diode, and T_S is the switching period.

This formula can be simplified as below:

$$D_{(MIN)} = \frac{V_{OUT}}{V_{IN(MAX)}} = \frac{T_{ON}}{T_S} ; 0 \leq D \leq 1$$

(2) Define a value of minimum current that is approximately 10%~30% of full load current to maintain continuous conduction mode, usually referred to as the critical current (I_{CRIT}).

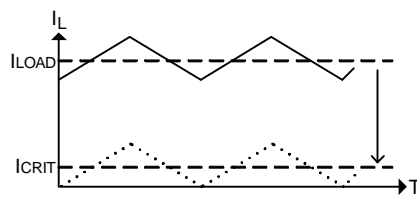

$$I_{CRIT} = \delta \times I_{LOAD} ; \delta = 0.1 \sim 0.3$$

(3) Calculate the inductor ripple current (ΔI_L). In steady state conditions, the inductor ripple current increase, (ΔI_{L+}), during the ON time and the current decrease, (ΔI_{L-}), during the OFF time must be equal.

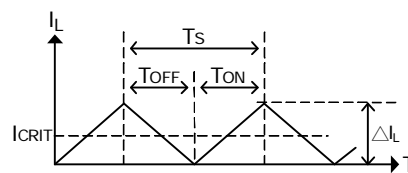

$$\Delta I_L = 2 \times I_{CRIT}$$

(4) Calculate the minimum value of inductor use maximum input voltage. That is the worst case condition because it gives the maximum ΔI_L .

$$L \geq \frac{[V_{IN(MAX)} - I_{LOAD} \times (R_{DS(ON)} + DCR) - V_{OUT}] \times D_{(MIN)}}{\Delta I_L \times f_s}$$

This formula can be simplified to

$$L \geq \frac{(V_{IN(MAX)} - V_{OUT}) \times D_{(MIN)}}{\Delta I_L \times f_s}$$

The higher inductance results in lower output ripple current and ripple voltage. But it requires larger physical size and price.

(5) Calculate the inductor peak current and choose a suitable inductor to prevent saturation.

$$I_{L(PEAK)} = I_{LOAD} + \frac{\Delta I_L}{2}$$

Coil inductors and surface mount inductors are all available. The surface mount inductors can reduce the board size but they are more expensive and its larger DC resistance results in more conduction loss. The power dissipation is due to the DC resistance can be calculated as below:

$$P_{D_INDUCTOR} = I_{LOAD}^2 \times DCR$$

Rectifier Diode Selection

The rectifier diode provides a current path for the inductor current when the internal power MOSFET turns off. The best solution is Schottky diode, and some parameters about the diode must be take care as below:

- (1) The forward current rating must be higher than the continuous output current.
- (2) The reverse voltage rating must be higher than the maximum input voltage.
- (3) The lower forward voltage will reduce the conduction loss.
- (4) The faster reverse recovery time will reduce the switching loss, but it is very small compared to conduction loss.
- (5) The power dissipation can be calculated by the forward voltage and output current for the time that the diode is conducting.

$$P_{D_DIODE} = I_{LOAD} \times V_F \times (1 - D)$$

Output Capacitor Selection

The functions of the output capacitor are to store energy and maintain the output voltage. The low ESR (Equivalent Series Resistance) capacitors are preferred to reduce the output ripple voltage (ΔV_{OUT}) and conduction loss. The output ripple voltage can be calculated as below:

$$\Delta V_{OUT} = \Delta I_L \times \left(ESR + \frac{1}{8 \times f_s \times C_{OUT}} \right)$$

Choose suitable capacitors must define the expectative value of output ripple voltage first.

The ESR of the aluminum electrolytic or the tantalum capacitor is an important parameter to determine the output ripple voltage. But the manufacturers usually do not specify ESR in the specifications. Assuming the capacitance is enough results in the output ripple voltage that due to

the capacitance can be ignored, the ESR should be limited to achieve the expectative output ripple voltage. The maximum ESR can be calculated as below:

$$ESR \leq \frac{\Delta V_{OUT}}{\Delta I_L}$$

Choose the output capacitance by the average value of the RC product as below:

$$C_{OUT} \approx \frac{50 \sim 80 \times 10^{-6}}{ESR_{_}C_{OUT}}$$

If low ESR ceramic capacitor is used as output capacitor, the output ripple voltage due to the ESR can be ignored results in most of the output ripple voltage is due to the capacitance. Therefore, the minimum output capacitance can be calculated as below:

$$C_{OUT(MIN)} \geq \frac{\Delta I_L}{8 \times f_s \times \Delta V_{OUT}}$$

The capacitors' ESR and ripple current result in power dissipation that will increase the internal temperature. Usually, the capacitors' manufacturers specify ripple current ratings and should not be exceeded to prevent excessive temperature shorten the life time. Choose a smaller inductor causes higher ripple current which maybe result in the capacitor overstress. The RMS ripple current flowing through the output capacitor and power dissipation can be calculated as below:

$$I_{RMS} = \frac{\Delta I_L}{\sqrt{12}} = \Delta I_L \times 0.289$$

$$P_{D_}C_{OUT} = I_{RMS}^2 \times ESR$$

The capacitor's ESL (Equivalent Series Inductance) maybe causes ringing in the low MHz region. Choose low ESL capacitors, limiting lead length of PCB and capacitor, and parallel connecting several smaller capacitors to replace with a larger one will reduce the ringing phenomenon.

Input Capacitor Selection

The input capacitor is required to supply current to the regulator and maintain the DC input voltage. Low ESR capacitors are preferred those provide the better performance and the less ripple voltage.

The input capacitors need an adequate RMS current rating. It can be calculated by following formula and should not be exceeded.

$$I_{RMS_}C_{IN} = I_{LOAD(MAX)} \times \sqrt{D \times (1 - D)}$$

This formula has a maximum at $V_{IN}=2V_{OUT}$. That is the worst case and the above formula can be simplified to:

$$I_{RMS_}C_{IN} = \frac{I_{LOAD(MAX)}}{2}$$

Therefore, choose a suitable capacitor at input whose ripple current rating must greater than half of the maximum load current.

The input ripple voltage (ΔV_{IN}) mainly depends on the input capacitor's ESR and its capacitance. Assuming the input current of the regulator is constant, the required input capacitance for a given input ripple voltage can be calculated as below:

$$C_{IN} = \frac{I_{LOAD(MAX)} \times D \times (1 - D)}{f_S \times (\Delta V_{IN} - I_{LOAD(MAX)} \times ESR)}$$

If using aluminum electrolytic or tantalum input capacitors, parallel connecting 0.1uF bypass capacitor as close to the regulator as possible. If using ceramic capacitor, make sure the capacitance is enough to prevent the excessive input ripple current.

The power dissipation of input capacitor causes a small conduction loss can be calculated as below:

$$P_{D_CIN} = (I_{RMS_CIN})^2 \times ESR$$

Loop Compensation Design

The current mode control scheme provides the faster transient response and easy to compensate because of eliminates the double pole of the output L-C filter. The system stability and transient response are controlled by compensation pin (COMP) that is the output of the transconductance error amplifier. The R-C network between COMP and GND sets pole-zero compensation to shape the close loop transfer function to get desired gain and phase.

The goal of the compensation design is to have a higher DC gain, enough phase margin, and higher bandwidth. The following figure shows the related components of the compensation loop.

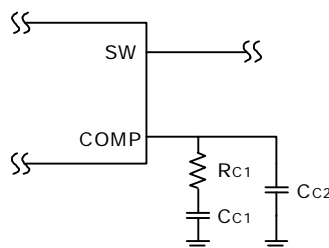

With current mode, the buck power stage can be simplified to be a 1 pole and 1 zero. The compensation network provides 2 poles and 1 zero. They are determined by the following formulas:

The DC loop gain is:

$$A_{VDC} = G_{CS} \times A_{VEA} \times \frac{V_{FB}}{I_{LOAD}}$$

The pole (f_{p1}) of the buck power stage due to the output capacitor, the load current, and the output voltage is:

$$f_{p1} = \frac{I_{LOAD}}{2\pi \times C_{OUT} \times V_{OUT}}$$

The zero (f_{z1}) of the buck power stage due to the output capacitor and its ESR is:

$$f_{z1} = \frac{1}{2\pi \times C_{OUT} \times ESR}$$

The pole (f_{p2}) due to the compensation capacitor (C_{C1}) and the output resistance of the error amplifier is:

$$f_{p2} = \frac{1}{2\pi \times C_{C1} \times (R_{C1} + \frac{A_{VEA}}{G_{EA}})} \approx \frac{G_{EA}}{2\pi \times C_{C1} \times A_{VEA}}$$

The zero (f_{z2}) due to the compensation capacitor (C_{C1}) and the compensation resistor (R_{C1}) is:

$$f_{z2} = \frac{1}{2\pi \times C_{C1} \times R_{C1}}$$

The pole (f_{p3}) due to the second compensation capacitor (C_{C2}) and the compensation resistor (R_{C1}) is:

$$f_{p3} = \frac{1}{2\pi \times C_{C2} \times R_{C1}}$$

The system crossover frequency (f_c) is defined to be the frequency where the feedback loop has unity gain. It is also called the bandwidth of the converter. Lower bandwidth causes poor transient response while higher bandwidth could cause system unstable.

In general, set the crossover frequency to be less than 1/10 of the switching frequency is recommended.

The loop compensation design guides are as below:

(1) Choose the compensation resistor (R_{C1}) to set the crossover frequency that should be less than 1/10 of the switching frequency. The R_{C1} can be calculated by the following formula:

$$R_{C1} = f_c \times \frac{V_{OUT}}{V_{FB}} \times \frac{2\pi \times C_{OUT}}{G_{EA} \times G_{CS}}$$

(2) Choose the compensation capacitor (C_{C1}) to achieve the desired phase margin. For applications with typical inductor values, setting the compensation zero (f_{z2}) to be less than 1/4 of the crossover frequency provides sufficient phase margin. The C_{C1} can be calculated by the

following formula:

$$C_{C1} = \frac{2}{\pi \times R_{C1} \times f_c}$$

(3) The second compensation capacitor (C_{C2}) is required if the ESR zero (f_{z1}) of the output capacitor is located at less than 1/2 of the switching frequency. If required, add the C_{C2} to set the compensation pole (f_{p3}) at location of the ESR zero (f_{z1}). The C_{C2} can be calculated by the following formula:

$$C_{C2} = \frac{C_{OUT} \times ESR}{R_{C1}}$$

Evaluation Board Layout

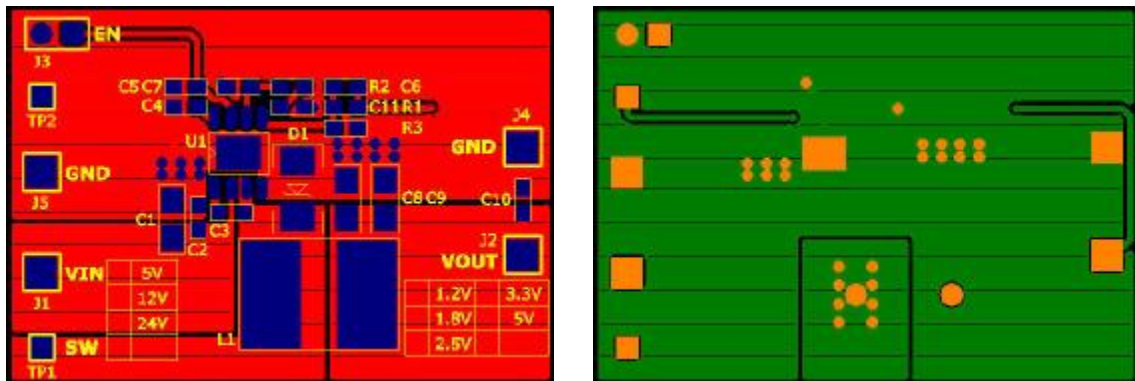

Evaluation Board Schematic

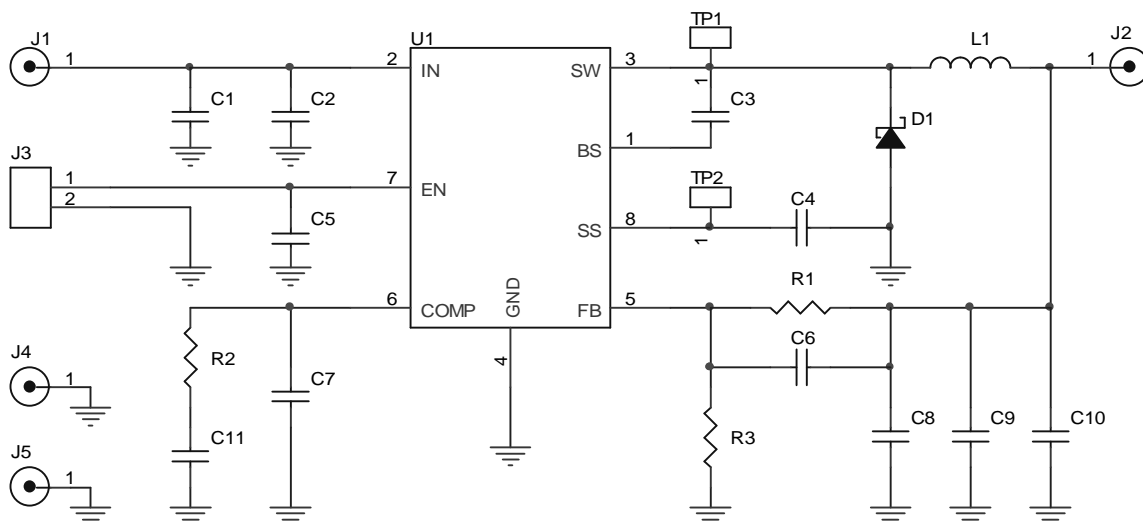

Key Components Supplier

Item	Manufacturer	Website	Manufacturer	Website
Inductor (L)	Chilisin	www.chilisin.com.tw	WE	www.we-online.com
Schottky Diode (D)	Formosa	www.formosams.com	Tip-Tek	www.tip-tek.com.tw
Electrolytic Capacitor (C)	NCC	www.chemi-con.co.jp	Jamicon	www.jamicon.com.tw
SMD Capacitor (C)	Yageo	www.yageo.com	Taiyo Yuden	www.yuden.co.jp
SMD Resistor (R)	Yageo	www.yageo.com		

Package Outline

ESOP-8

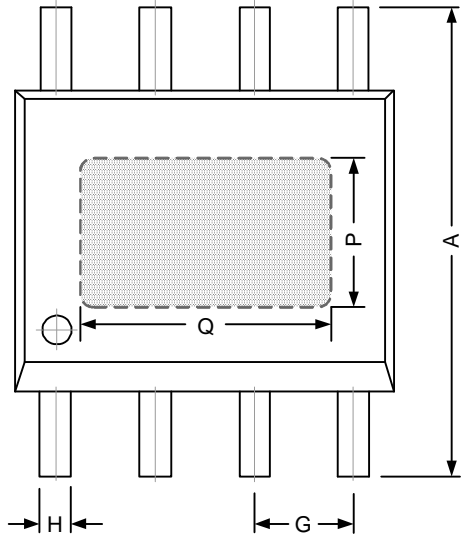

REF.	DIMENSIONS	
	Millimeter	
	Min.	Max.
A	5.80	6.20
B	4.80	5.00
C	3.80	4.00
D	0°	8°
E	0.40	0.90
F	0.19	0.25
M	0.10	0.25
H	0.35	0.49
L	1.35	1.75
P	2.30	2.50
Q	3.20	3.40
J	0.375 REF.	
K	45°	
G	1.27 TYP.	

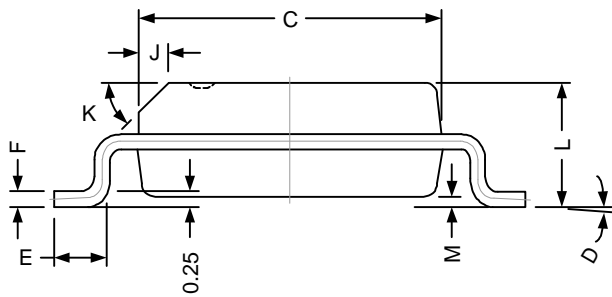
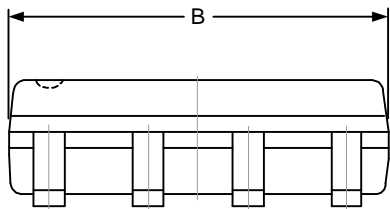

NOTICE

The specifications and product information of INNO-TECH Co., Ltd. are subject to change without any prior notice, and customer should contact INNO-TECH Co., Ltd. to obtain the latest relevant information before placing orders and verify that such information is current and complete.

The information provided here is believed to be reliable and accurate; however INNO-TECH Co., Ltd. makes no guarantee for any errors that appear in this document.

LIFE SUPPORT POLICY

INNO-TECH products are not designed or authorized for use as critical components in life support devices or systems without the express written approval of the president of INNO-TECH Co., Ltd. As used herein:

1. Life support devices or systems are devices or systems which, (a) are intended for surgical implant into the body, or (b) support or sustain life, and (c) whose failure to perform when properly used in accordance with instructions for use provided in the labeling, can be reasonably expected to result in a significant injury of the user.
2. A critical component in any component of a life support device or system whose failure to perform can be reasonably expected to cause the failure of the life support device or system, or to affect its safety or effectiveness.