

### General Description

LA8521 is a voltage mode, step-down DC-DC converter that is designed to meet 5A output current, and utilizes PWM control scheme that switches with 300KHz fixed frequency.

The input voltage range of LA8521 is from 3.6V to 23V, and available in adjustable output voltage from 0.8V to  $V_{IN}$ . The supply current is only 3mA during operation and under 1uA in shutdown.

This device provides an enable function that can be controlled by external logic signal. It also provides excellent regulation during line or load transient. Other features of current limit, thermal shutdown protection, and short circuit protection are also included. Due to the low  $R_{DS(ON)}$  of the internal power MOSFET, this device provides high efficiency step-down applications. It can also operate with a maximum duty cycle of 100% for use in low drop-out conditions. The package is available in standard ESOP-8.

### Ordering Information

LA8521 1 2 3 4

- 1 (Package Type) => P: ESOP
- 2 (Number of Pins) => G: 8 pin
- 3 (Output Voltage) => Blank: Adjustable
- 4 (Special Feature) => Blank: N/A

#### Available Part Number

LA8521PG

### Features

- | Adjustable Output Voltage from 0.8V to  $V_{IN}$
- | 3.6V to 23V Input Voltage Range
- | Continuous 5A Output Capability
- | 300KHz Oscillation Frequency
- | 0.8V Reference Voltage
- | 1uA Low Shutdown Current
- | 3mA Low Supply Current
- | 100% Duty Cycle
- | Built-in Low  $R_{DS(ON)}$  Power MOSFET
- | No External Compensation Required
- | Adjustable Current Limit
- | Short Circuit Protection
- | Thermal Shutdown Protection
- | ESOP-8 Package
- | Meet RoHS Standard

### Applications

- | Broadband Communication Device
- | LCD TV / Monitor
- | Storage Device
- | Wireless Application

### Marking Information

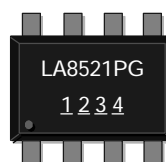

1 2 (Date Code)

For date code rule, please contact our sales representative directly.

3 4 (Internal Code)

### Typical Application

12V to 5V,  $I_{OUT}=5A$

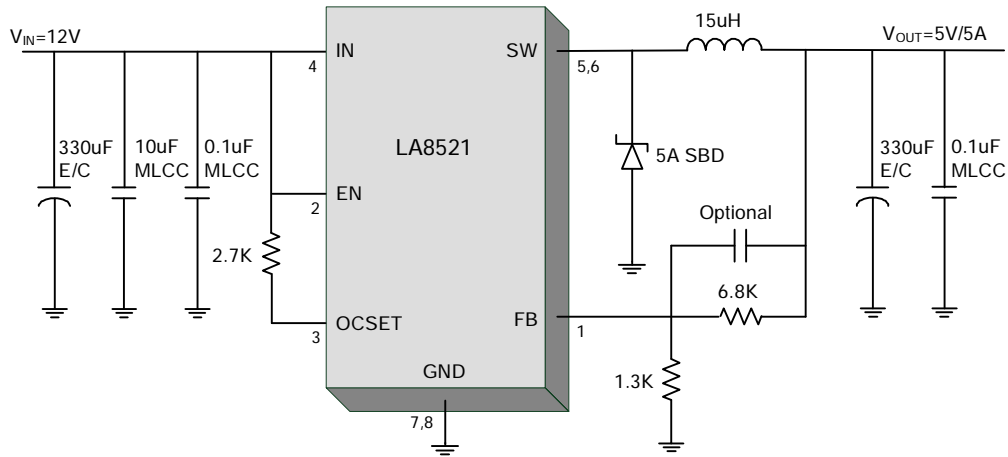

### Efficiency Curve

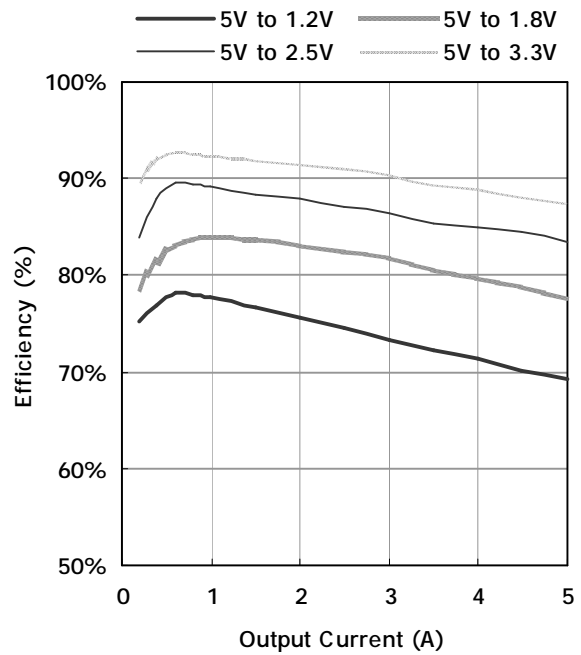
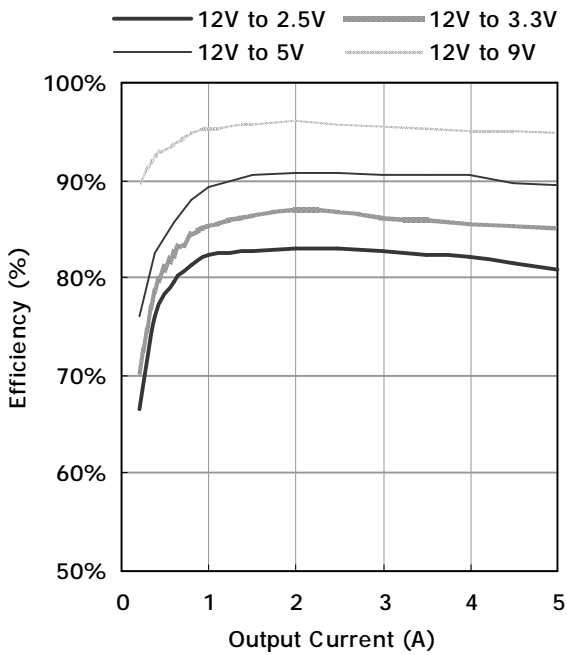

Quick Design Table

For 5A output current,  $\Delta I_L = 1A$ , continuous current mode operation.

The recommended input capacitors ( $C_{IN}$ ) are "330uF/EC + 10uF/MLCC + 0.1uF/MLCC", and the output capacitors ( $C_{OUT}$ ) are "330uF/EC + 0.1uF/MLCC". The compensation capacitor ( $C_C$ ) is the optional part, 220pF~1nF is recommended if needed.

- L1:** Recommended Inductor
- R1:** Output Voltage Divider
- R2:** Output Voltage Divider
- R3:** Current Limit Setting Resistor

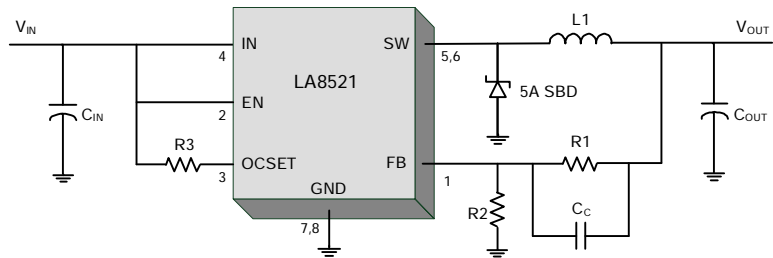

$V_{OUT} \backslash V_{IN}$	5V	9V	12V	18V
1.2V	L1 : 4.7uH R1 : 1.5KOhm R2 : 3KOhm R3 : 4.7KOhm			
1.5V	L1 : 6.8uH R1 : 1.3KOhm R2 : 1.5KOhm R3 : 4.7KOhm	L1 : 6.8uH R1 : 1.3KOhm R2 : 1.5KOhm R3 : 3.3KOhm		
1.8V	L1 : 5.6uH R1 : 2.5KOhm R2 : 2KOhm R3 : 4.7KOhm	L1 : 6.8uH R1 : 2.5KOhm R2 : 2KOhm R3 : 3.3KOhm		
2.5V	L1 : 6.8uH R1 : 4.7KOhm R2 : 2.2KOhm R3 : 4.7KOhm	L1 : 8.2uH R1 : 4.7KOhm R2 : 2.2KOhm R3 : 3.3KOhm	L1 : 10uH R1 : 4.7KOhm R2 : 2.2KOhm R3 : 2.7KOhm	
3.3V	L1 : 4.7uH R1 : 4.7KOhm R2 : 1.5KOhm R3 : 4.7KOhm	L1 : 10uH R1 : 4.7KOhm R2 : 1.5KOhm R3 : 3.3KOhm	L1 : 10uH R1 : 4.7KOhm R2 : 1.5KOhm R3 : 2.7KOhm	L1 : 12uH R1 : 4.7KOhm R2 : 1.5KOhm R3 : 3.3KOhm
5V		L1 : 10uH R1 : 6.8KOhm R2 : 1.3KOhm R3 : 3.3KOhm	L1 : 15uH R1 : 6.8KOhm R2 : 1.3KOhm R3 : 2.7KOhm	L1 : 15uH R1 : 6.8KOhm R2 : 1.3KOhm R3 : 3.3KOhm
9V			L1 : 10uH R1 : 10.2KOhm R2 : 1KOhm R3 : 2.7KOhm	L1 : 22uH R1 : 10.2KOhm R2 : 1KOhm R3 : 3.3KOhm
12V				L1 : 18uH R1 : 18.2KOhm R2 : 1.3KOhm R3 : 3.3KOhm

### Functional Block Diagram

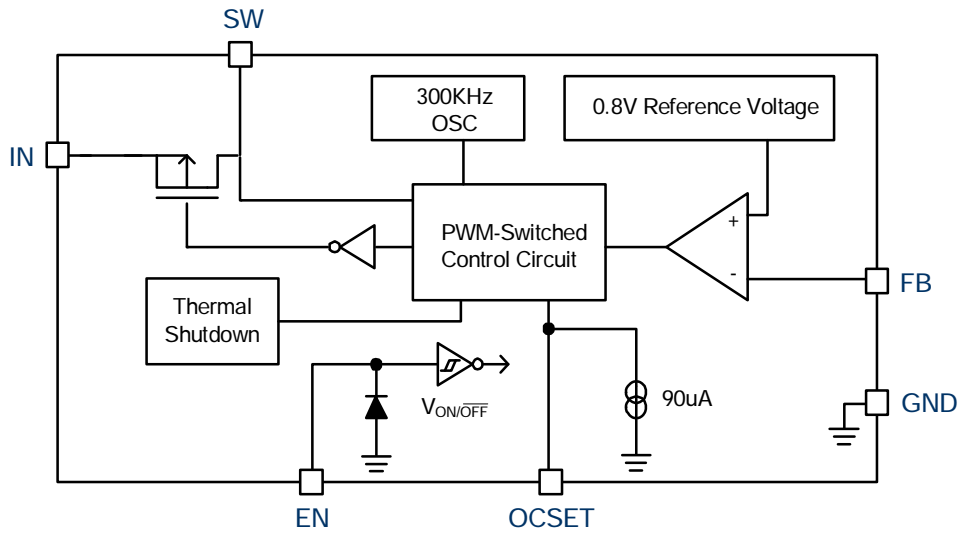

### Pin Configurations

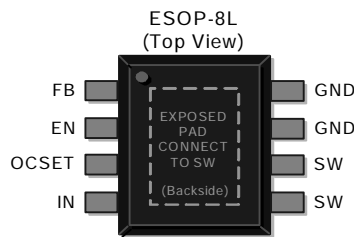

Pin No.	Name	Description
1	FB	This pin senses the feedback voltage to regulate the output voltage. Connect this pin to a voltage divider to set the output voltage.
2	EN	This pin allows an external control signal to turn-on/off this device. Float this pin or force it below 0.8V to turn-off this device, force it above 2V to turn-on this device. If this feature is not needed, connect this pin to IN directly.
3	OCSET	Add an external resistor from this pin to IN to set current Limit.
4	IN	The input pin of the step-down converter. A suitably large capacitor must be connected from this pin to ground to bypass noise on the input of the IC.
5,6	SW	The output pin of the step-down converter. This pin is the switching node that supplies power to the output. Connect a LC filter from this pin to the output load and a rectifier diode to the ground.
7,8	GND	The ground pin of the step-down converter. Connect this pin to the circuit ground.

## Absolute Maximum Ratings

Parameter	Rating
Input Voltage	25V
SW Pin Voltage Range	-0.5V ~ $V_{IN}+0.5V$
FB Pin Voltage Range	-0.3V ~ $V_{IN}$
EN Pin Voltage Range	-0.3V ~ $V_{IN}+0.3V$
Storage Temperature Range	-65°C ~ 150°C
Junction Temperature	150°C
Lead Soldering Temperature (10 sec)	300°C

These are stress ratings only and functional operation is not implied. Exposure to absolute maximum ratings for prolonged time periods may affect device reliability. All voltages are with respect to ground.

## Recommended Operating Conditions

Parameter	Rating
Input Voltage Range	3.6V ~ 23V
Ambient Temperature Range	-40°C ~ 85°C
Junction Temperature Range	-40°C ~ 125°C

These are conditions under which the device functions but the specifications might not be guaranteed. For guaranteed specifications and test conditions, please see the *Electrical Specifications*.

## Package Information

Parameter	Package	Symbol	Rating
Thermal Resistance (Junction to Case)	ESOP-8	$\theta_{JC}$	10 °C/W
Thermal Resistance (Junction to Ambient)		$\theta_{JA}$	50 °C/W

## Electrical Specifications

$V_{IN}=12V$ ,  $V_{OUT}$  set to 3.3V,  $T_A=25^{\circ}C$ , unless otherwise noted.

Parameter	Symbol	Test Condition	Min.	Typ.	Max.	Units
Feedback Voltage	$V_{FB}$	$I_{LOAD}=0.1A$	0.784	0.8	0.816	V
Efficiency	$\eta$	$V_{IN}=12V$ , $V_{OUT}=5V$ , $I_{LOAD}=5A$		90		%
		$V_{IN}=5V$ , $V_{OUT}=3.3V$ , $I_{LOAD}=5A$		88		
Oscillation Frequency	$F_{OSC}$		240	300	360	KHz
Frequency of Short Circuit Protection	$F_{SCP}$		30	50	70	KHz
Duty Cycle	DC	$V_{FB}=0V$		100		%
		$V_{FB}=1.5V$		0		
Internal MOSFET ON Resistance	$R_{DS(ON)}$	$V_{IN}=5V$ , $V_{FB}=0V$		45		m $\Omega$
		$V_{IN}=12V$ , $V_{FB}=0V$		35		
Supply Current	$I_S$	$V_{FB}=1.5V$		3	10	mA
Shutdown Current	$I_{SD}$	$V_{EN}=0V$		1	10	$\mu A$
EN Pin Input Threshold Voltage	$V_{EN}$	Regulator OFF		1.3	0.8	V
		Regulator ON	2.0			
EN Pin Bias Current	$I_{EN}$	Regulator OFF		1		$\mu A$
		Regulator ON		20		
FB Pin Bias Current	$I_{FB}$	$I_{LOAD}=0.1A$		0.1	0.5	$\mu A$
OCSET Pin Bias Current	$I_{OCSET}$	$I_{LOAD}=0.1A$	75	90	105	$\mu A$
Line Regulation	$\Delta V_{LINE}$	$V_{IN}=3.6V \sim 23V$ , $I_{LOAD}=0.1A$		2		%
Load Regulation	$\Delta V_{LOAD}$	$I_{LOAD}=0.1A \sim 5A$		0.1		%
Over Temperature Shutdown	$T_{SD}$			150		$^{\circ}C$
Over Temperature Shutdown Hysteresis	$T_{HYS}$			25		$^{\circ}C$

## Typical Performance Characteristics

$V_{IN}=12V$ ,  $V_{OUT}$  set to 3.3V,  $T_A=25^{\circ}C$ , unless otherwise noted.

Frequency vs. Input Voltage

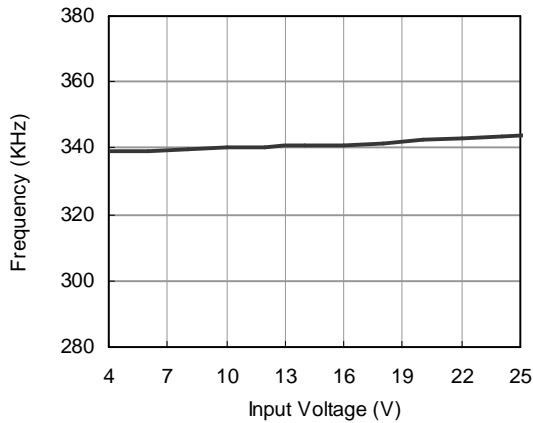

Frequency vs. Temperature

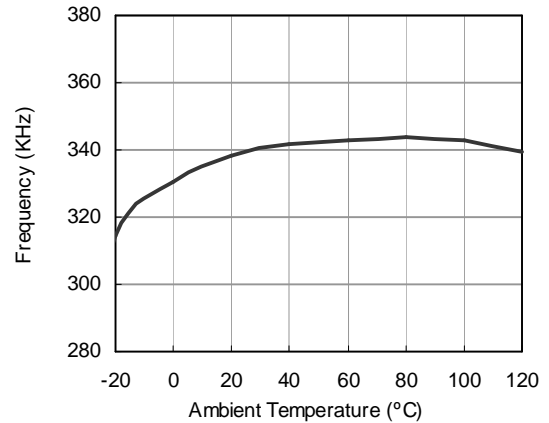

Feedback Voltage vs. Input Voltage

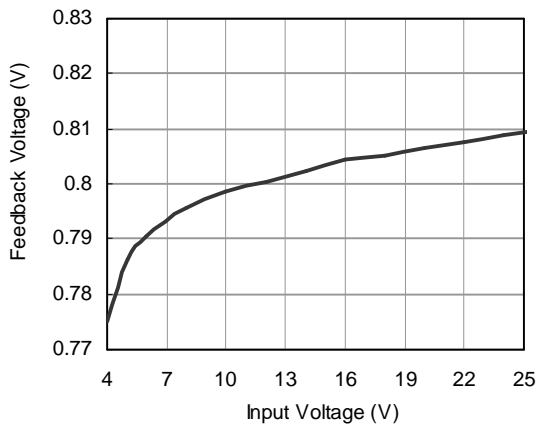

Feedback Voltage vs. Temperature

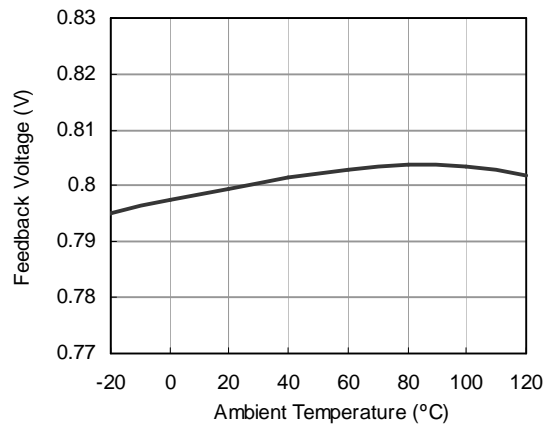

Short Circuit Frequency vs. Input Voltage

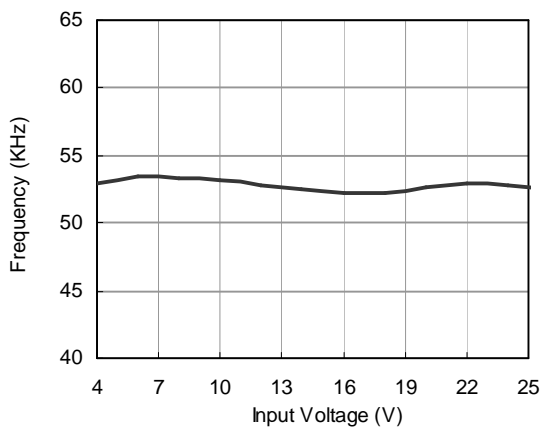

OCSET Current vs. Input Voltage

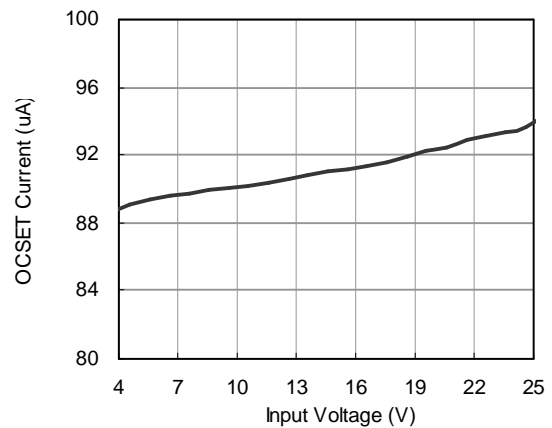

**Typical Performance Characteristics (Contd.)**

*Supply Current vs. Input Voltage*

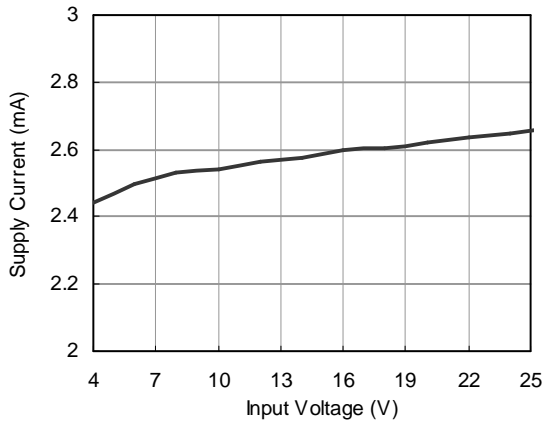

*Shutdown Current vs. Input Voltage*

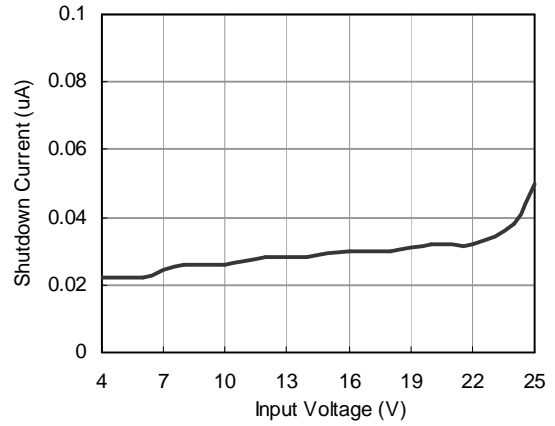

*Line Regulation*

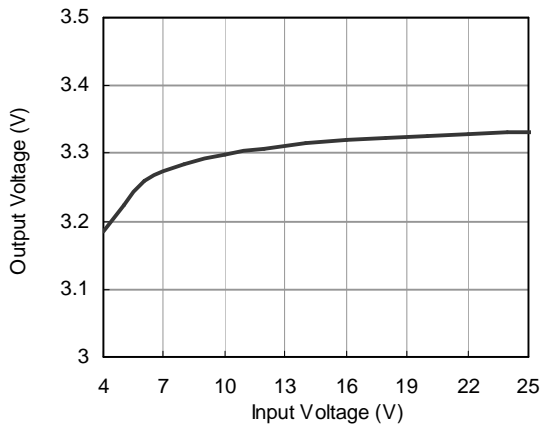

*Load Regulation*

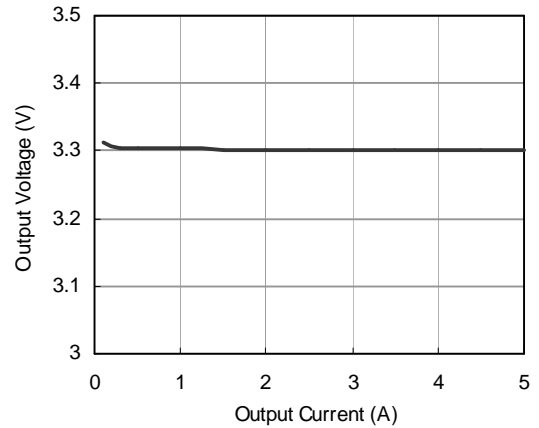

*Power MOSFET  $R_{DS(ON)}$  vs. Input Voltage*

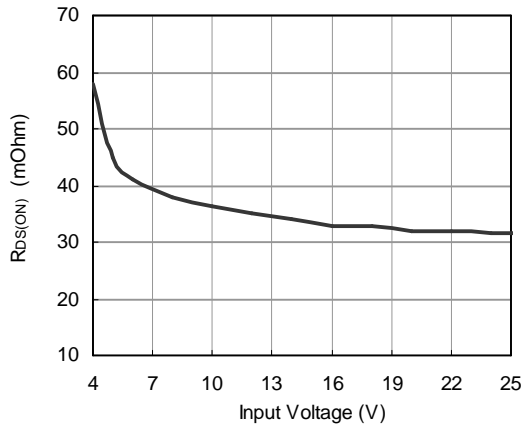



Typical Performance Characteristics (Contd.)

**Output Voltage Ripple - CCM**

$V_{IN}=12V$   $V_{OUT}=5V$ ,  $I_{LOAD}=5A$

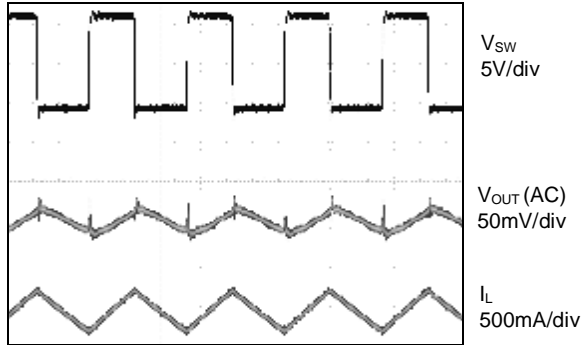

Time Base: 2us/div

**Output Voltage Ripple - DCM**

$V_{IN}=12V$   $V_{OUT}=5V$ ,  $I_{LOAD}=0.05A$

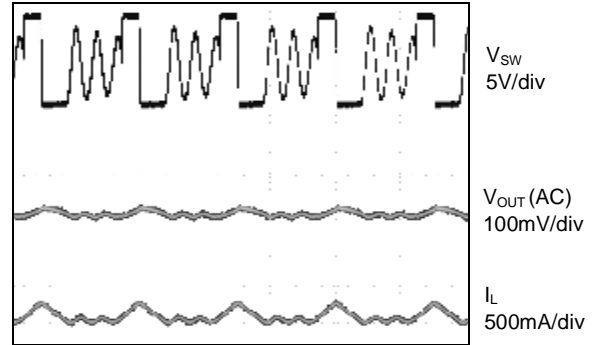

Time Base: 2us/div

**Start-up**

$V_{IN}=12V$   $V_{OUT}=5V$ ,  $I_{LOAD}=5A$

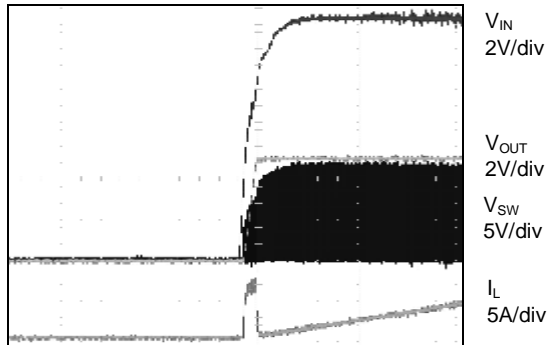

Time Base: 2ms/div

**Start-up from Enable**

$V_{IN}=12V$   $V_{OUT}=5V$ ,  $I_{LOAD}=5A$

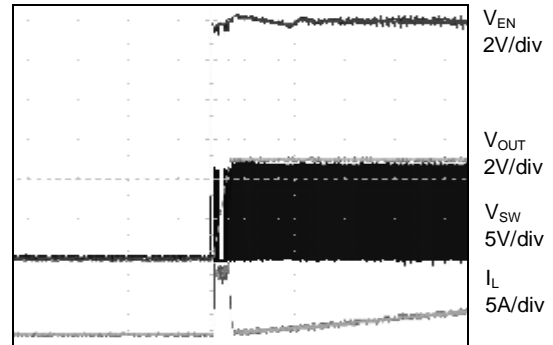

Time Base: 1ms/div

**Load Transient**

$V_{IN}=12V$   $V_{OUT}=5V$ ,  $I_{LOAD}=200mA\sim 5A$   
 $T_{ON}=T_{OFF}=1ms$ ,  $T_r=T_f=100mA/us$

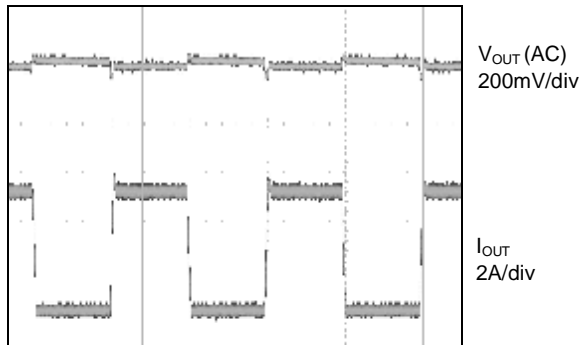

Time Base: 1ms/div

**Short Circuit Protection**

$V_{IN}=12V$   $V_{OUT}=5V$ ,  $I_{LOAD}=5A$

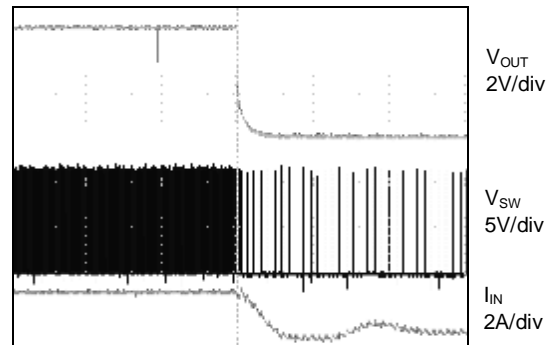

Time Base: 200us/div

## Application Information

### Output Voltage Programming

LA8521 develops a band-gap between the feedback pin and ground pin. Therefore, the output voltage can be formed by R1 and R2. Use 1% metal film resistors for the lowest temperature coefficient and the best stability. Select lower resistor value to minimize noise pickup in the sensitive feedback pin, or higher resistor value to improve efficiency.

The output voltage is given by the following formula:

$$V_{OUT} = V_{FB} \times ( 1 + R1 / R2 ) \quad \text{where } V_{FB} = 0.8V$$

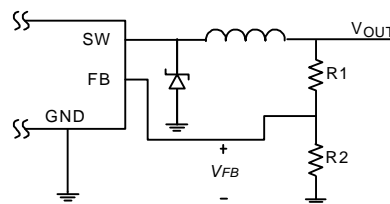

### Short Circuit Protection

When the output is shorted to ground, the protection circuit will be triggered and force the oscillation frequency down to approximately 50KHz. The oscillation frequency will return to 300KHz once the output voltage or the feedback voltage rises above 0V.

### Current Limit Setting

This device reserves OCSET pin to set the switching peak current. In general, the peak current must be 1.5 times of the continuous output current. It can be calculated as below:

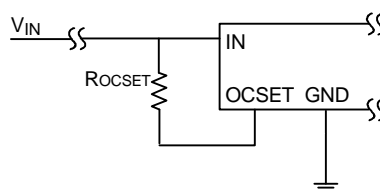

$$I_{CL} = (I_{OCSET} \times R_{OCSET}) / R_{DS(ON)}$$

Where  $I_{CL}$  is the current limit,  $I_{OCSET}$  is the OCSET bias current (90uA Typ.), and  $R_{DS(ON)}$  is the ON-resistance of the internal power MOSFET.

### Delay Start-up

The following circuit uses the EN pin to provide a time delay between the input voltage is applied and the output voltage comes up. As the instant of the input voltage rises, the charging of capacitor  $C_{DELAY}$  pulls the EN pin low, keeping the device off. Once the capacitor voltage rises above

the EN pin threshold voltage, the device will start to operate. The start-up delay time can be calculated by the following formula:

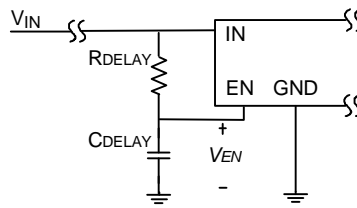

$$V_{IN} \times (1 - e^{-T/(R \times C)}) > V_{EN}$$

Where T is the start-up delay time, R is  $R_{DELAY}$ , C is  $C_{DELAY}$ , and the typical  $V_{EN}$  is 1.3V.

This feature is useful in situations where the input power source is limited in the amount of current it can deliver. It allows the input voltage to rise to a higher voltage before the device starts operating.

### Snubber Circuit

The simple RC snubber is used for voltage transient and ringing suppression. The high frequency ringing and voltage overshooting at the SW pin is caused by fast switching transition and resonating circuit parasitical elements in the power circuit. It maybe generates EMI and interferes with circuit performance. Reserve a snubber circuit in the PC board is preferred to damp the ringing due to the parasitical capacitors and inductors of layout. The following circuit is a simple RC snubber:

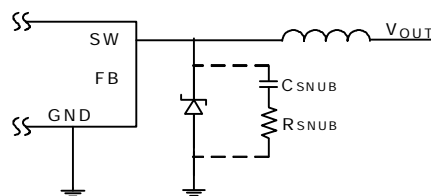

Choose the value of RC network by the following procedure:

- (1) Measure the voltage ringing frequency ( $f_R$ ) of the SW pin.
- (2) Find a small capacitor and place it across the SW pin and the GND pin to damp the ringing frequency by half.
- (3) The parasitical capacitance ( $C_{PAR}$ ) at the SW pin is 1/3 the value of the added capacitance above. The parasitical inductance ( $L_{PAR}$ ) at the SW pin is:

$$L_{PAR} = \frac{1}{(2\pi f_R)^2 \times C_{PAR}}$$

- (4) Select the value of  $C_{SNUB}$  that should be more than 2~4 times the value of  $C_{PAR}$  but must be small enough so that the power dissipation of  $R_{SNUB}$  is kept to a minimum.

The power rating of  $R_{SNUB}$  can be calculated by following formula:

$$P_{RSNUB} = C_{SNUB} \times V_{IN}^2 \times f_s$$

(5) Calculate the value of  $R_{SNUB}$  by the following formula and adjust the value to meet the expectative peak voltage.

$$R_{SNUB} = 2\pi \times f_R \times L_{PAR}$$

### Thermal Considerations

Thermal protection limits total power dissipation in this device. When the junction temperature reaches approximately 150°C, the thermal sensor signals the shutdown logic turning off this device. The thermal sensor will turn this device on again after the IC's junction temperature cools by approximately 25°C. For continuous operation, do not exceed the maximum operation junction temperature 125°C.

The power dissipation across this device can be calculated by the following formula:

$$P_D = I_{LOAD}^2 \times R_{DS(ON)} \times \frac{V_{OUT}}{V_{IN}} + \frac{1}{2} \times V_{IN} \times I_{OUT} \times (t_r + t_f) \times f_s + Q_g \times V_{GS} \times f_s + V_{IN} \times I_s$$

Where  $f_s$  is the 300KHz switching frequency,  $(t_r + t_f)$  is the switching time that is approximately 50ns,  $Q_g$  is the power MOSFET gate charge that is approximately 20nC,  $V_{GS}$  is the gate voltage of the power MOSFET that is approximately equal  $V_{IN}$ , and  $I_s$  is the 3mA supply current.

The maximum power dissipation of this device depends on the thermal resistance of the IC package and PCB layout, the temperature difference between the die junction and ambient air, and the rate of airflow. The maximum power dissipation can be calculated by the following formula:

$$P_{D(MAX)} = \frac{(T_J - T_A)}{\theta_{JA}}$$

Where  $T_J - T_A$  is the temperature difference between the die junction and surrounding environment,  $\theta_{JA}$  is the thermal resistance from the junction to the surrounding environment.

The value of junction to case thermal resistance  $\theta_{JC}$  is also popular to users. This thermal parameter is convenient for users to estimate the internal junction operated temperature of packages while IC operating. The operated junction temperature can be calculated by the following formula:

$$T_J = T_C + P_D \times \theta_{JC}$$

$T_C$  is the package case temperature measured by thermal sensor. Therefore it's easy to estimate the junction temperature by any condition.

There are many factors affect the thermal resistance. Some of these factors include trace width, copper thickness, total PCB copper area, and etc. For the best thermal performance, wide copper traces and generous amounts of PCB copper should be used in the board layout. If further improve thermal characteristics are needed, double sided and multi-layer PCB with large copper areas and airflow will be recommended.

### *Layout Considerations*

PC board layout is very important, especially for switching regulators of high frequencies and large peak currents. A good layout minimizes EMI on the feedback path and provides best efficiency. The following layout guides should be used to ensure proper operation of this device.

- (1) The power charge path that consists of the IN trace, the SW trace, the external inductor and the GND trace should be kept wide and as short as possible.
- (2) The power discharge path that consists of the SW trace, the external inductor, the rectifier diode and the GND trace should be kept wide and as short as possible.
- (3) The feedback path of voltage divider should be close to the FB pin and keep noisy traces away; also keep them separate using grounded copper.
- (4) The input capacitors should be close to the regulator and rectifier diode.
- (5) The output capacitors should be close to the load.

## Component Selection

### Inductor Selection

The conduction mode of power stage depends on input voltage, output voltage, output current, and the value of the inductor. Select an inductor to maintain this device operating in continuous conduction mode (CCM). The minimum value of inductor can be determined by the following procedure.

(1) Calculate the minimum duty ratio:

$$D_{(MIN)} = \frac{V_{OUT} + I_{LOAD} \times DCR + V_F}{V_{IN(MAX)} - I_{LOAD} \times R_{DS(ON)} + V_F} = \frac{T_{ON}}{T_S}$$

Where DCR is the DC resistance of the inductor,  $V_F$  is the forward voltage of the rectifier diode, and  $T_S$  is the switching period.

This formula can be simplified as below:

$$D_{(MIN)} = \frac{V_{OUT}}{V_{IN(MAX)}} = \frac{T_{ON}}{T_S} ; 0 \leq D \leq 1$$

(2) Define a value of minimum current that is approximately 10%~30% of full load current to maintain continuous conduction mode, usually referred to as the critical current ( $I_{CRIT}$ ).

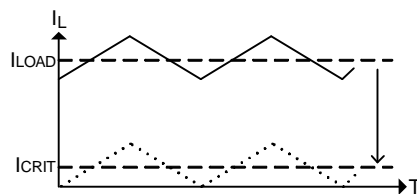

$$I_{CRIT} = \delta \times I_{LOAD} ; \delta = 0.1 \sim 0.3$$

(3) Calculate the inductor ripple current ( $\Delta I_L$ ). In steady state conditions, the inductor ripple current increase, ( $\Delta I_{L+}$ ), during the ON time and the current decrease, ( $\Delta I_{L-}$ ), during the OFF time must be equal.

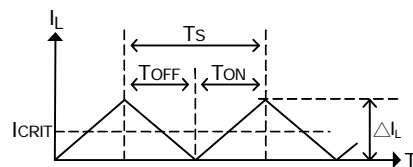

$$\Delta I_L = 2 \times I_{CRIT}$$

(4) Calculate the minimum value of inductor use maximum input voltage. That is the worst case condition because it gives the maximum  $\Delta I_L$ .

$$L \geq \frac{[V_{IN(MAX)} - I_{LOAD} \times (R_{DS(ON)} + DCR) - V_{OUT}] \times D_{(MIN)}}{\Delta I_L \times f_s}$$

This formula can be simplified to

$$L \geq \frac{(V_{IN(MAX)} - V_{OUT}) \times D_{(MIN)}}{\Delta I_L \times f_s}$$

The higher inductance results in lower output ripple current and ripple voltage. But it requires larger physical size and price.

(5) Calculate the inductor peak current and choose a suitable inductor to prevent saturation.

$$I_{L(PEAK)} = I_{LOAD} + \frac{\Delta I_L}{2}$$

Coil inductors and surface mount inductors are all available. The surface mount inductors can reduce the board size but they are more expensive and its larger DC resistance results in more conduction loss. The power dissipation is due to the DC resistance can be calculated as below:

$$P_{D\_INDUCTOR} = I_{LOAD}^2 \times DCR$$

### Rectifier Diode Selection

The rectifier diode provides a current path for the inductor current when the internal power MOSFET turns off. The best solution is Schottky diode, and some parameters about the diode must be take care as below:

- (1) The forward current rating must be higher than the continuous output current.
- (2) The reverse voltage rating must be higher than the maximum input voltage.
- (3) The lower forward voltage will reduce the conduction loss.
- (4) The faster reverse recovery time will reduce the switching loss, but it is very small compared to conduction loss.
- (5) The power dissipation can be calculated by the forward voltage and output current for the time that the diode is conducting.

$$P_{D\_DIODE} = I_{LOAD} \times V_F \times (1 - D)$$

### Output Capacitor Selection

The functions of the output capacitor are to store energy and maintain the output voltage. The low ESR (Equivalent Series Resistance) capacitors are preferred to reduce the output ripple voltage ( $\Delta V_{OUT}$ ) and conduction loss. The output ripple voltage can be calculated as below:

$$\Delta V_{OUT} = \Delta I_L \times \left( ESR_{\_COUT} + \frac{1}{8 \times f_s \times C_{OUT}} \right)$$

Choose suitable capacitors must define the expectative value of output ripple voltage first.

The ESR of the aluminum electrolytic or the tantalum capacitor is an important parameter to determine the output ripple voltage. But the manufacturers usually do not specify ESR in the specifications. Assuming the capacitance is enough results in the output ripple voltage that due to

the capacitance can be ignored, the ESR should be limited to achieve the expectative output ripple voltage. The maximum ESR can be calculated as below:

$$ESR_{\_COUT} \leq \frac{\Delta V_{OUT}}{\Delta I_L}$$

Choose the output capacitance by the average value of the RC product as below:

$$C_{OUT} \approx \frac{50 \sim 80 \times 10^{-6}}{ESR_{\_COUT}}$$

If low ESR ceramic capacitor is used as output capacitor, the output ripple voltage due to the ESR can be ignored results in most of the output ripple voltage is due to the capacitance. Therefore, the minimum output capacitance can be calculated as below:

$$C_{OUT(MIN)} \geq \frac{\Delta I_L}{8 \times f_s \times \Delta V_{OUT}}$$

The prerequisites for using low ESR output ceramic capacitors are Duty Cycle > 0.275 and feed-forward capacitor must be used to stabilize the control loop.

The capacitors' ESR and ripple current result in power dissipation that will increase the internal temperature. Usually, the capacitors' manufacturers specify ripple current ratings and should not be exceeded to prevent excessive temperature shorten the life time. Choose a smaller inductor causes higher ripple current which maybe result in the capacitor overstress. The RMS ripple current flowing through the output capacitor and power dissipation can be calculated as below:

$$I_{RMS\_COUT} = \frac{\Delta I_L}{\sqrt{12}} = \Delta I_L \times 0.289$$

$$P_{D\_COUT} = (I_{RMS\_COUT})^2 \times ESR_{\_COUT}$$

The capacitor's ESL (Equivalent Series Inductance) maybe causes ringing in the low MHz region. Choose low ESL capacitors, limiting lead length of PCB and capacitor, and parallel connecting several smaller capacitors to replace with a larger one will reduce the ringing phenomenon.

### *Input Capacitor Selection*

The input capacitor is required to supply current to the regulator and maintain the DC input voltage. Low ESR capacitors are preferred those provide the better performance and the less ripple voltage.

The input capacitors need an adequate RMS current rating. It can be calculated by following formula and should not be exceeded.

$$I_{RMS\_CIN} = I_{LOAD(MAX)} \times \sqrt{D \times (1 - D)}$$



This formula has a maximum at  $V_{IN}=2V_{OUT}$ . That is the worst case and the above formula can be simplified to:

$$I_{RMS\_CIN} = \frac{I_{LOAD(MAX)}}{2}$$

Therefore, choose a suitable capacitor at input whose ripple current rating must greater than half of the maximum load current.

The input ripple voltage ( $\Delta V_{IN}$ ) mainly depends on the input capacitor's ESR and its capacitance. Assuming the input current of the regulator is constant, the required input capacitance for a given input ripple voltage can be calculated as below:

$$C_{IN} = \frac{I_{LOAD(MAX)} \times D \times (1 - D)}{f_S \times (\Delta V_{IN} - I_{LOAD(MAX)} \times ESR_{\_CIN})}$$

If using aluminum electrolytic or tantalum input capacitors, parallel connecting 0.1uF bypass capacitor as close to the regulator as possible. If using ceramic capacitor, make sure the capacitance is enough to prevent the excessive input ripple current.

The power dissipation of input capacitor causes a small conduction loss can be calculated as below:

$$P_{D\_CIN} = (I_{RMS\_CIN})^2 \times ESR_{\_CIN}$$

*Evaluation Board Layout*

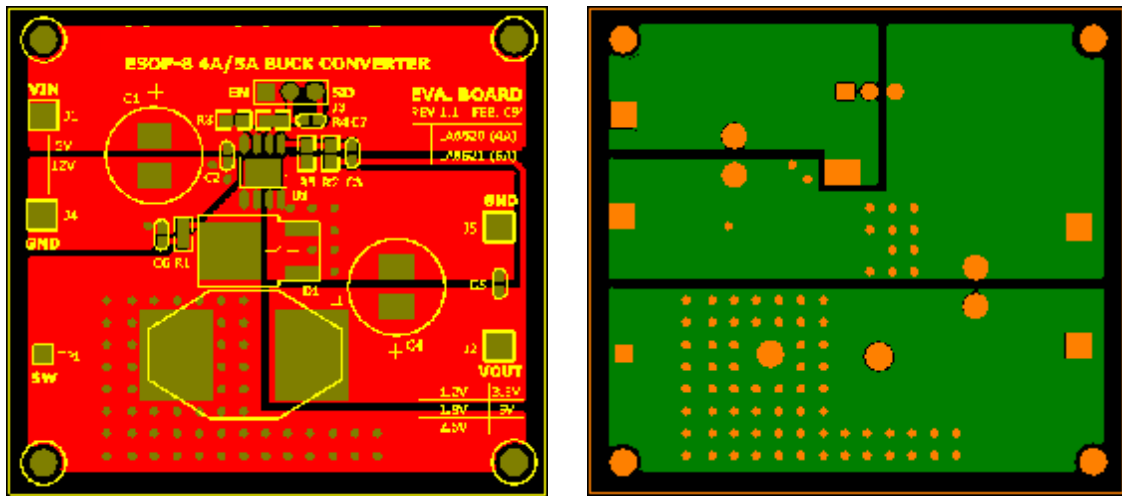

*Evaluation Board Schematic*

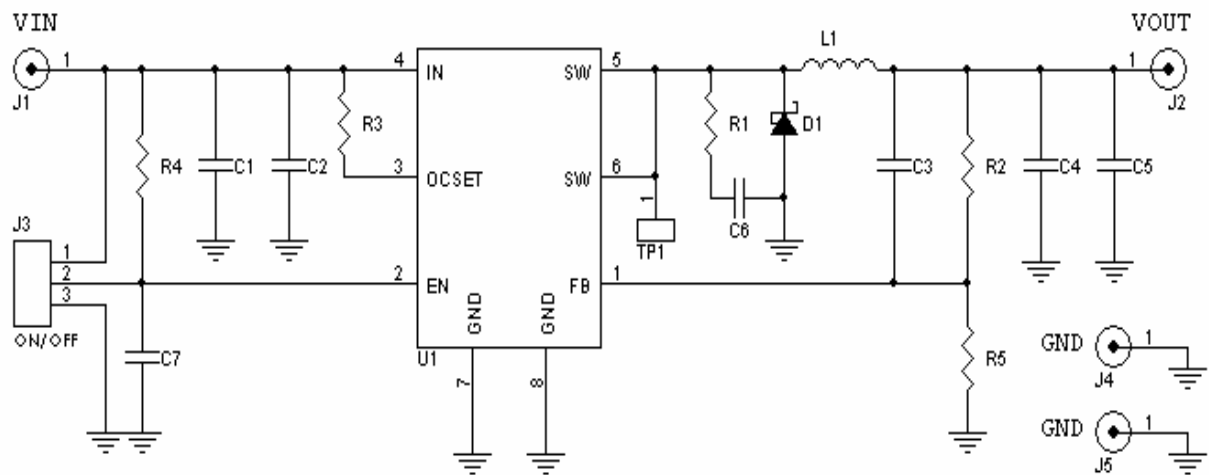

## Bill of Materials

$V_{IN}=12V$ ,  $V_{OUT}=5V$ ,  $I_{OUT}=5A$

Designation	Descriptions	Manufacturer Part #	Manufacturer	Manufacturer Website
U1	300KHz, 5A Step-Down DC-DC Converter ESOP-8 Package	LA8521PG	INNO-TECH	www.inno.com.tw
L1	Surface Mount Inductor 15uH 8A 0.036Ohm	SSL1306T-150M-N	Chilisin	www.chilisin.com.tw
	Choke 15uH 7.2A 0.015Ohm	TDH1420T-150K-N	Chilisin	www.chilisin.com.tw
D1	DPAK Schottky Diode 40V 6A 0.55V <sub>F</sub>	SKFM640Y-D	Formosa	www.formosams.com
C1	MLCC 22uF, 1210, X5R, 16V	C3225X5R1C226M	TDK	www.tdk.com
		EMK325BJ226MM-T	Taiyo Yuden	www.yuden.co.jp
C4	Low ESR E/C 330uF, 25V, 8x15mm	EKY-250EXX331MH15D	NCC	www.chemi-con.co.jp
		WLR331M1EF15	Jamicon	www.jamicon.com.tw
C2,C5	MLCC 0.1uF, 0805, X7R, 50V	UMK212BJ104KG	Taiyo Yuden	www.yuden.co.jp
	MLCC 0.1uF, 0603, B, 50V	C1608JB1H104K	TDK	www.tdk.com
C3,C6,C7	Optional Parts			
R2	Chip Resistor, 6.8KOhm, 0805, ±1%	RC0805FR-076K8L	Yageo	www.yageo.com
R3	Chip Resistor, 2.7KOhm, 0805, ±1%	RC0805FR-072K7L	Yageo	www.yageo.com
R5	Chip Resistor, 1.3KOhm, 0805, ±1%	RC0805FR-071K3L	Yageo	www.yageo.com
R1,R4	Optional Parts			
J3	Male Header 180° 3*1P 2.54mm			
J1,J2,J4,J5	Terminal Binding Post 1.6mm			
TP1	Male Header 180° 1P 2.54mm			

Package Outline

ESOP-8

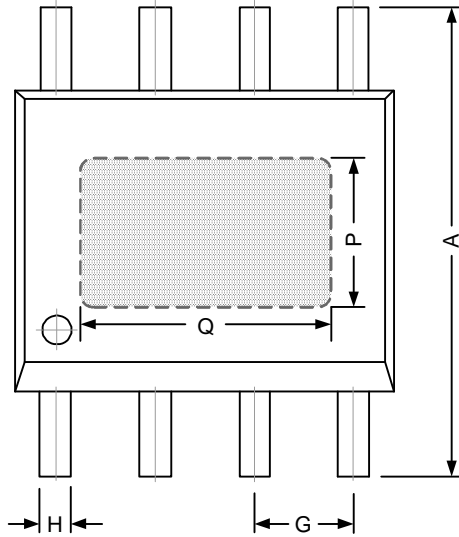

REF.	DIMENSIONS	
	Millimeter	
	Min.	Max.
A	5.80	6.20
B	4.80	5.00
C	3.80	4.00
D	0°	8°
E	0.40	0.90
F	0.19	0.25
M	0.10	0.25
H	0.35	0.49
L	1.35	1.75
P	2.30	2.50
Q	3.20	3.40
J	0.375 REF.	
K	45°	
G	1.27 TYP.	

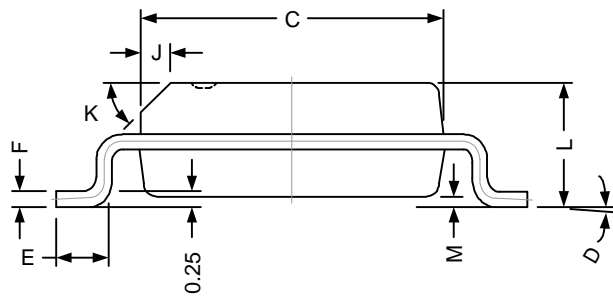
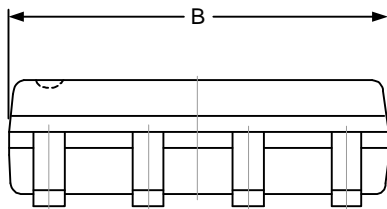

#### *NOTICE*

The specifications and product information of INNO-TECH Co., Ltd. are subject to change without any prior notice, and customer should contact INNO-TECH Co., Ltd. to obtain the latest relevant information before placing orders and verify that such information is current and complete.

The information provided here is believed to be reliable and accurate; however INNO-TECH Co., Ltd. makes no guarantee for any errors that appear in this document.

#### *LIFE SUPPORT POLICY*

INNO-TECH products are not designed or authorized for use as critical components in life support devices or systems without the express written approval of the president of INNO-TECH Co., Ltd. As used herein:

1. Life support devices or systems are devices or systems which, (a) are intended for surgical implant into the body, or (b) support or sustain life, and (c) whose failure to perform when properly used in accordance with instructions for use provided in the labeling, can be reasonably expected to result in a significant injury of the user.
2. A critical component in any component of a life support device or system whose failure to perform can be reasonably expected to cause the failure of the life support device or system, or to affect its safety or effectiveness.