



FEATURES

- * Guaranteed Power Dissipation 50 Watts @ 80°C case
- * Guaranteed input-output differential: +2.6 Volts
- * Low noise, band-gap reference
- * Sample power cycled burn-in
- * Guaranteed thermal resistance junction to case: 0.9°C/W
- * TO-247 package

DESCRIPTION

The LAS 1900P voltage regulators are monolithic integrated circuits designed for use in applications requiring a well regulated positive output voltage over line and load variations. Outstanding features include full power usage up to 5.0 amperes of load current, internal current limiting, thermal shutdown, and safe area protection on the chip, providing protection of the series pass darlington, under most operating conditions. TO-247 plastic packages are utilized for high current and lower thermal resistance. A low-noise temperature stable band-gap reference is the key design factor insuring excellent temperature regulation of the LAS 1900P. This, coupled to a very low output impedance, insures superior load regulation.

BLOCK DIAGRAM

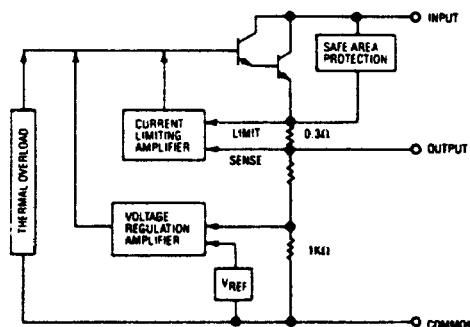

10/27/88

DEVICE SELECTION GUIDE

V_{OUT}	V_{OUT} TOLERANCE		
	+5%	+5%, -3%	+2%
5	LAS 1905P	LAS 1905BP	LAS 19A05P
12	LAS 1912P	LAS 1912BP	LAS 19A12P
15	LAS 1915P	LAS 1915BP	LAS 19A15P

ABSOLUTE MAXIMUM RATINGS

PARAMETER	SYMBOL	MINIMUM	MAXIMUM	UNITS
Input Voltage	V_{IN}		30(35) ⁽¹⁾⁽²⁾	Volts
Power Dissipation	P_D		Internally Limited ⁽³⁾	
Thermal Resistance Junction To Case	θ_{JC}		0.9	°C/Watt
Operating Junction Temperature Range	T_J	0	125	°C
Storage Temperature Range	T_{STG}	-65	150	°C
Lead Temperature (Soldering, 60 Seconds Time Limit)	T_{LEAD}		300	°C

- (1) Short circuit protection is only assured to V_{IN} max. Value of 30V applies to V_O of +5V to +12V. Value of 35V apply to V_O of 15V.
- (2) In case of short circuit with input-output voltages approaching V_{IN} max, regulator may require the removal of the input voltage to restart.
- (3) For operation above 80°C T_{CASE} , derate @ 1.111 watt/°C.

ELECTRICAL CHARACTERISTICS

Input voltage test conditions are as follows: $V_1 = V_D + 3$ Volts, $V_2 = V_D + 10$ Volts, $V_3 = V_D + 15$ Volts, or the maximum input, whichever is less.

Unless otherwise stated, specifications apply for $0^\circ\text{C} \leq T_J \leq 125^\circ\text{C}$.

Parameter	Symbol	Test Conditions			Test Limits		Units
		V_{IN}	I_D	T_J	Min	Max	
Output Voltage ² LAS 1900 ¹ LAS 1900B ¹ LAS 19A00 ¹	V_D	V_1 to V_2	10mA to 5.0A	25°C	0.95 V_D 0.97 V_D 0.98 V_D	1.05 V_D 1.05 V_D 1.02 V_D	
Input-Output Differential	$V_{IN}-V_D$		5.0A	0-125°C	2.6		
Line Regulation ²	$REG_{(LINE)}$	V_1 to V_3	3.0A	25°C		1.0	$\%V_D$
Load Regulation ²	$REG_{(LOAD)}$	V_1	10mA to 5.0A	25°C		0.6	$\%V_D$
Quiescent Current	I_Q	V_1	10mA	25°C		25	mA
Quiescent Current Line	$I_Q_{(LINE)}$	V_1 to V_2	10mA	25°C		5.0	mA
Quiescent Current Load	$I_Q_{(LOAD)}$	V_1	10mA to 5.0A	25°C		5.0	mA
Current Limit ²	I_{LIM}	$V_D + 5V$		25°C		15	Amps
Temperature Coefficient	T_C	V_1	0.1A	0-125°C		0.03	$\%V_D/^\circ\text{C}$
Output Noise ³ Voltage	V_N	V_1	0.1A	0-125°C		10	$\mu\text{Vrms/V}$
Ripple Attenuation ⁴	R_A	$V_D + 5V$	2.0A	0-125°C	60		dB
Power Dissipation	P_D	$V_{IN} - V_{OUT}$ 2.6 to 10	10mA to 5.0A	0-125°C		50	Watts

- 1) Nominal output voltages are specified under Device Selection Guide.
- 2) Low duty cycle pulse testing with Kelvin connections required.
Die temperature changes must be accounted for separately.
- 3) BW = 10Hz - 100 kHz
- 4) Ripple attenuation is specified for a 1Vrms, 120kHz, input ripple.
Ripple attenuation is minimum of 60dB at 5V output and is 1dB less for each volt increase in the output voltage.

OPERATIONAL DATA

POWER DERATING

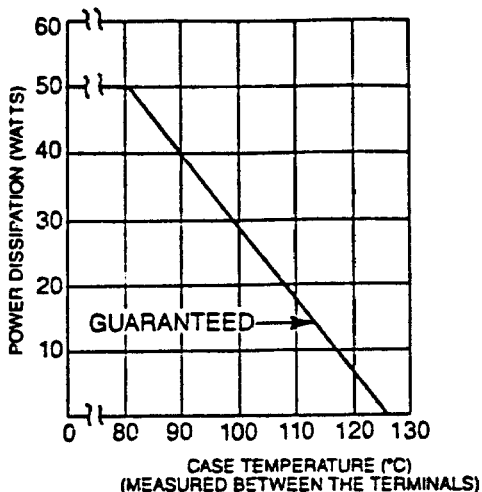

CURRENT LIMIT

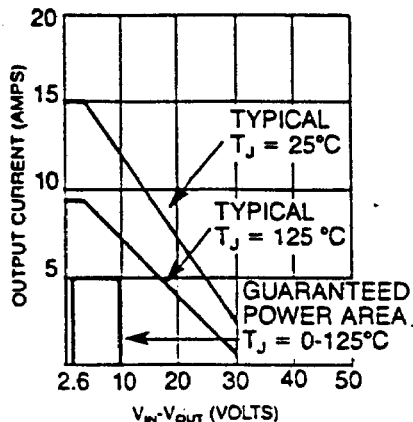

TYPICAL RIPPLE ATTENUATION VS FREQUENCY

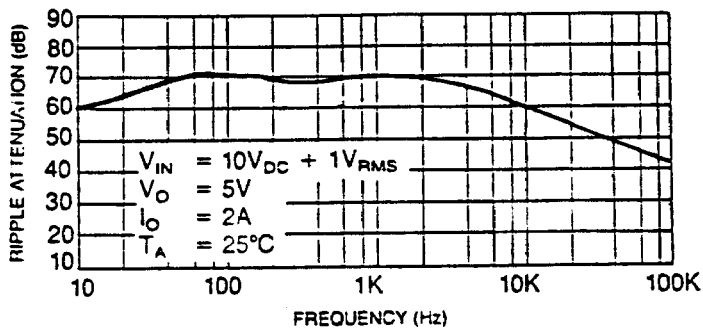

TYPICAL INPUT-OUTPUT VOLTAGE DIFFERENTIAL VS JUNCTION TEMPERATURE

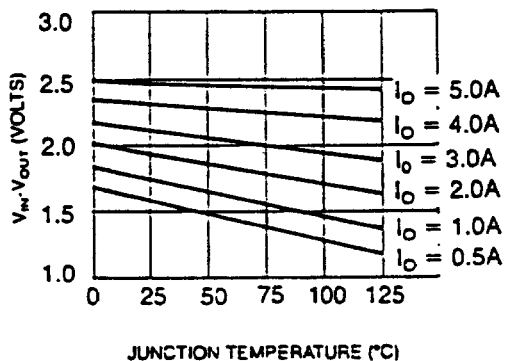

TYPICAL OUTPUT IMPEDANCE VS FREQUENCY

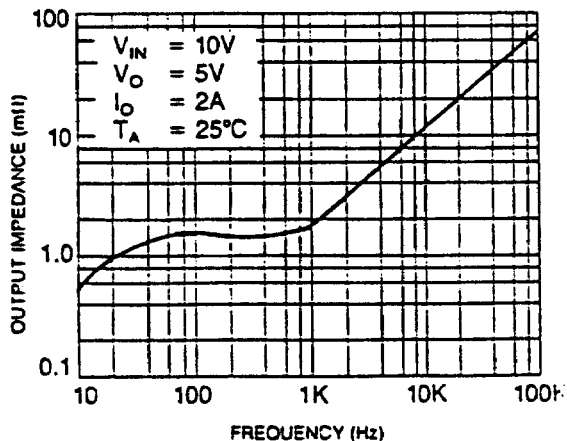

TYPICAL APPLICATIONS

FIXED VOLTAGE REGULATOR

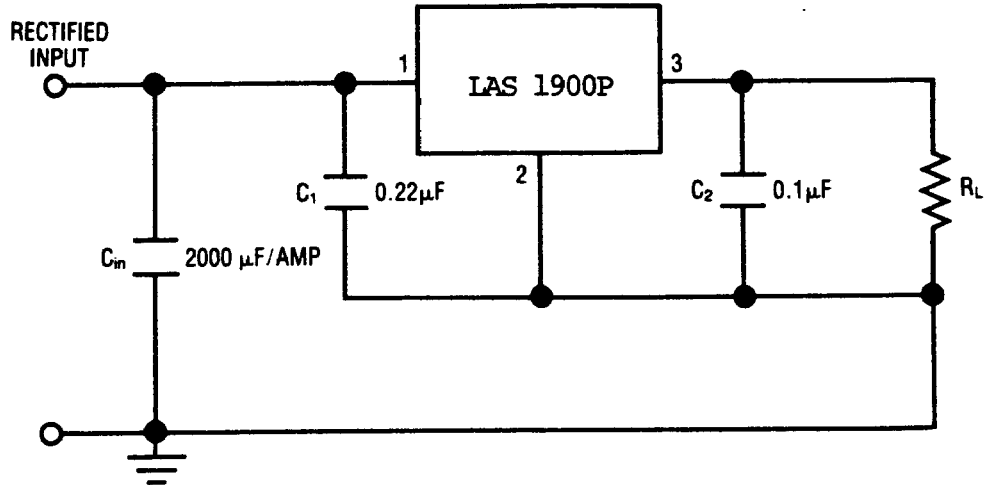

FIXED CURRENT REGULATOR

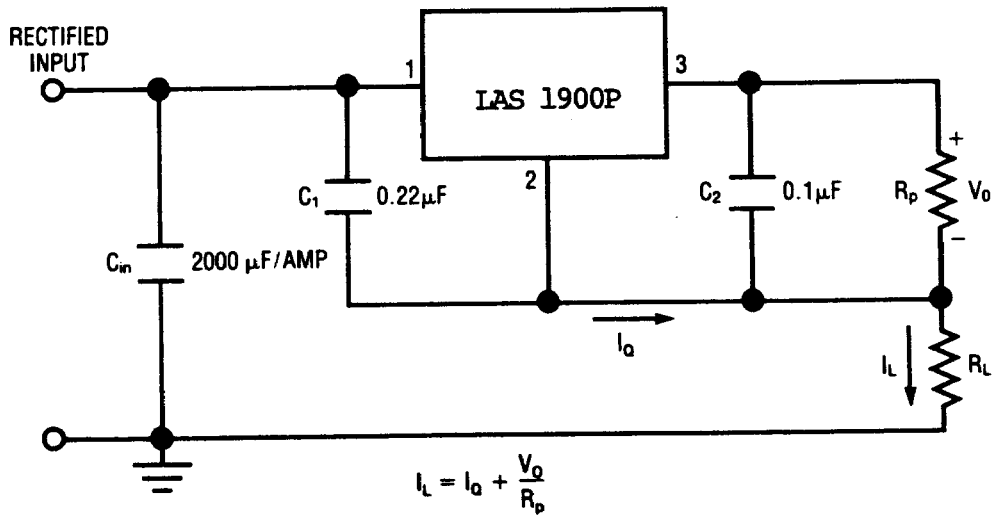

DEVICE OUTLINE

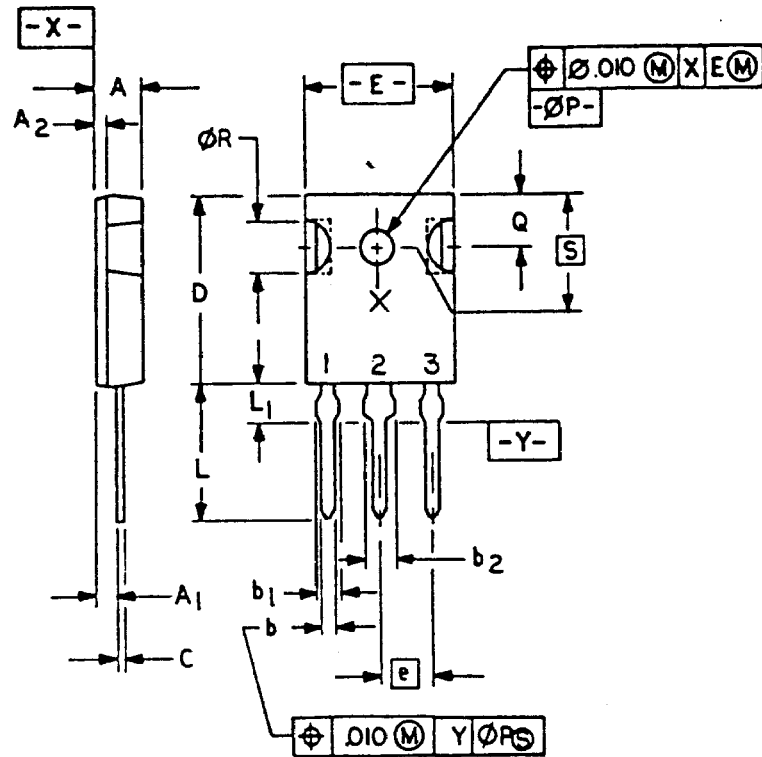

SYMBOL	MIN. MAX.	
	A	.185
A ₁	.087	.102
A ₂	.059	.098
b	.046	.055
b ₁	.079	.094
b ₂	.118	.133
c	.016	.031
D	.776	.799
E	.602	.625
e	.215 BSC	
L	.559	.582
L ₁	.146	.169
Øp	.118	.133
Q	.209	.224
ØR	.178	.216
S	.217 BSC	

1 - INPUT
 2 - COMMON
 3 - OUTPUT
 TAB IS COMMON

NOTE: CASE TEMPERATURE MEASURED AT POINT X.
 ALL DIMENSIONS ARE IN INCHES.

DEVICE OUTLINE

T-58-11-13

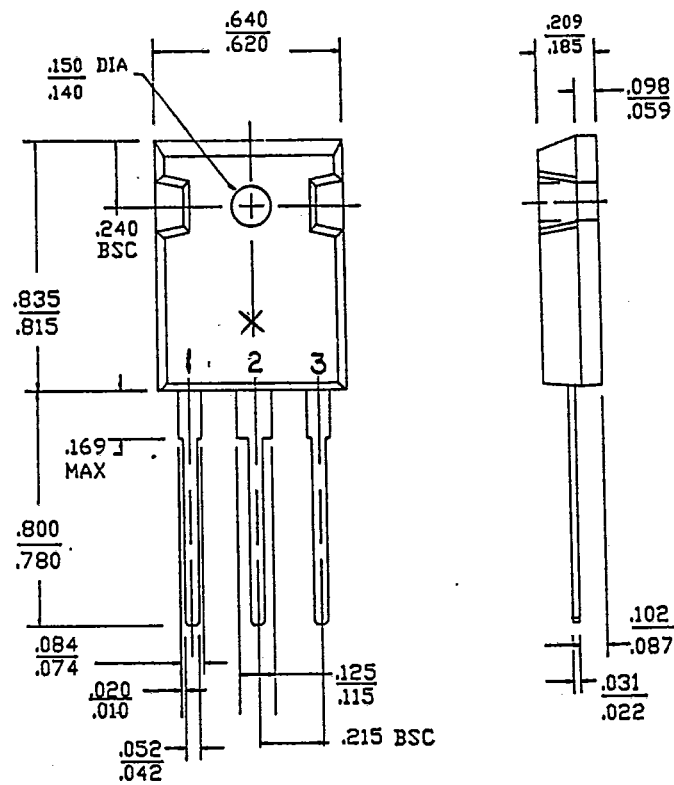

1	-	INPUT
2	-	COMMON
3	-	OUTPUT
TAB IS COMMON		

NOTE: CASE TEMPERATURE MEASURED AT POINT X.
ALL DIMENSIONS ARE IN INCHES.