

5 AMP, 85 WATT POSITIVE HYBRID VOLTAGE REGULATORS

LAS 2100

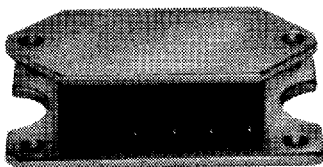

FEATURES

- 0.1% line regulation
- 0.2% load regulation
- 0.015% temperature coefficient
- Low noise
- $\pm 1\%$ output voltage tolerance
- Electrically isolated case

DESCRIPTION

The LAS 2100 Series of Power Hybrid Voltage Regulators is designed for applications requiring a well regulated, low noise, output voltage for load current variations up to 5.0 amperes. A key feature of the Power Hybrid Voltage Regulator is its construction. A high degree of thermal isolation between the heat generating power elements and the heat sensitive control and reference elements is achieved by placing the power section on the heat-dissipating base of the unit and the control state on the upper surface. This thermal isolation results in extremely low thermal drift characteristics for changes in power levels.

ABSOLUTE MAXIMUM RATINGS

PARAMETER	SYMBOL	MAXIMUM	UNITS
Input Voltage	V_{IN}	40	Volts
Input-Output Voltage Differential	$V_{IN}-V_O$	37.5	Volts
Power Dissipation ¹	P_D	85	Watts
Thermal Resistance Junction to Case ²	θ_{JC}	2.0	$^{\circ}\text{C}/\text{Watt}$
Thermal Resistance Junction to Ambient	θ_{JA}	15.0	$^{\circ}\text{C}/\text{Watt}$
Operating Junction Temperature Range ³	T_J	0 to 200	$^{\circ}\text{C}$
Storage Temperature Range	T_S	-55 to 125	$^{\circ}\text{C}$
Lead Temperature (Soldering, 10 seconds)	T_{LEAD}	215	$^{\circ}\text{C}$

⁽¹⁾ Output current vs. input-output voltage differential must be maintained per the Safe Operating Area curves.

⁽²⁾ Case 1, heat-dissipating base.

⁽³⁾ Darlington transistor, power section.

DEVICE SELECTION GUIDE

DEVICE	OUTPUT VOLTAGE (VOLTS)	OUTPUT CURRENT (AMPS)
LAS 2105	5	5
LAS 2112	12	5
LAS 2115	15	5
LAS 2124	24	3

BLOCK DIAGRAM

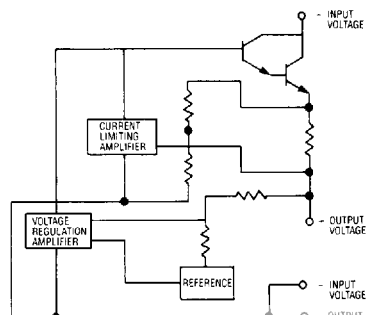

www.DataSheet4U.com

5 AMP, 85 WATT POSITIVE HYBRID VOLTAGE REGULATORS

ELECTRICAL CHARACTERISTICS

Input voltage test conditions are as follows: $V_1 = V_0 + 4.6$ Volts,
 $V_2 = V_1 + 10$ Volts, or the maximum input, whichever is less.

Parameter	Symbol	Test Conditions			Test Limits			Units
		V_{IN}	I_O	T_J	Minimum	Typical	Maximum	
Output Voltage ¹	V_O	V_1 to V_2	0A to I_{RATED}	25°C	0.99 V_{O1}		1.01 V_{O1}	Volts
Input-Output Voltage Differential ²	$V_{IN} - V_O$		$< I_{RATED}$	25-125°C	4.6		37.5	Volts
Line Regulation	$REG_{(LINE)}$	V_1 to V_2	0A	25°C			0.1	% V_O
Load Regulation	$REG_{(LOAD)}$	V_1	0A to I_{RATED}	25°C			0.2	% V_O
Quiescent Current	I_Q	V_1	0A	25°C			10.0	mA
Temperature Coefficient	T_C	V_1	0.5 I_{RATED}	0 - 125°C			0.015	%/°C
Ripple Attenuation ³	R_A	$V_O + 10V$	0.5 I_{RATED}	25-125°C	60			dB

⁽¹⁾ Nominal output voltages and rated currents are specified under Device Selection Guide.

⁽²⁾ Power dissipation must be maintained per the Power Derating curve.

Output current vs. input-output voltage differential must be maintained per the Safe Operating Area curves.

⁽³⁾ Ripple attenuation is specified for a 1Vrms, 120Hz input ripple. Ripple attenuation is 54dB minimum for 24V model.

TYPICAL APPLICATION

POSITIVE VOLTAGE REGULATOR^{1,2,3}

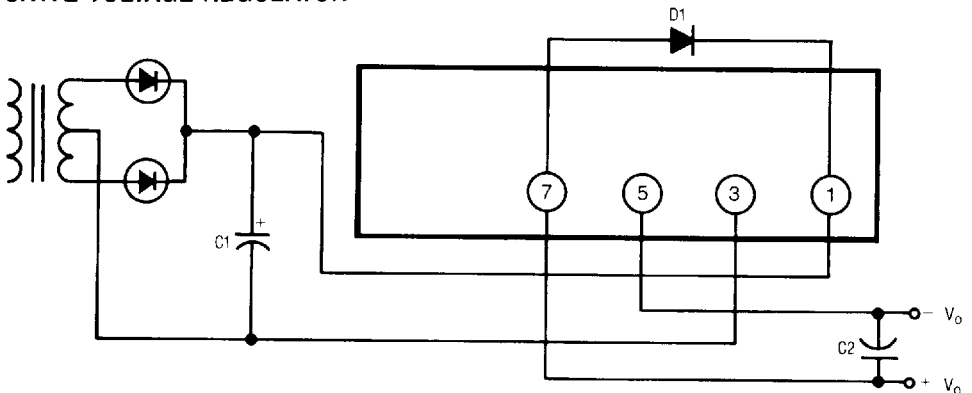

¹ Minimum value of input filter capacitor: $C1 = I_O \times 1000\mu F/Amp$

² Minimum value of output capacitor: $C2 = I_O \times 100\mu F/Amp$

³ External diode D1 provides reverse bias protection.

5 AMP, 85 WATT POSITIVE HYBRID VOLTAGE REGULATORS

LAS 2100

OPERATIONAL DATA

POWER DERATING

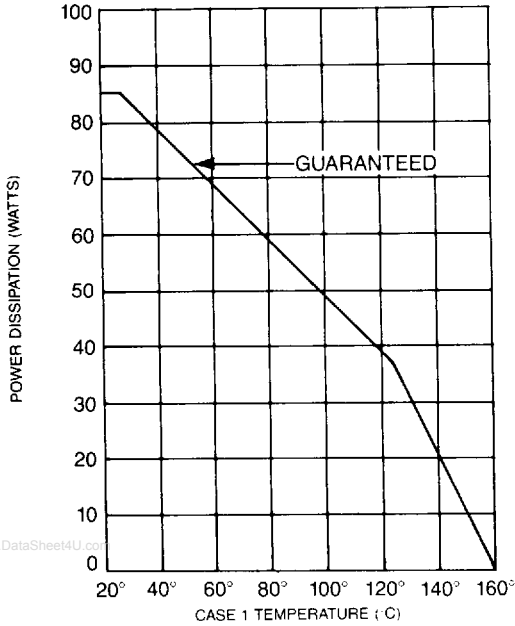

SHORT CIRCUIT PROTECTION

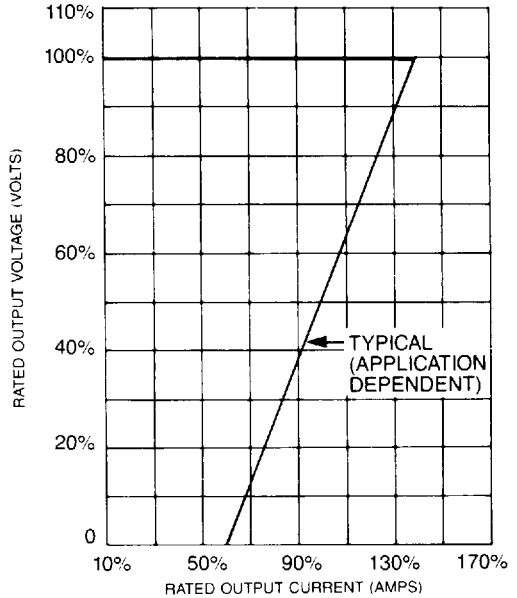

SAFE OPERATING AREA

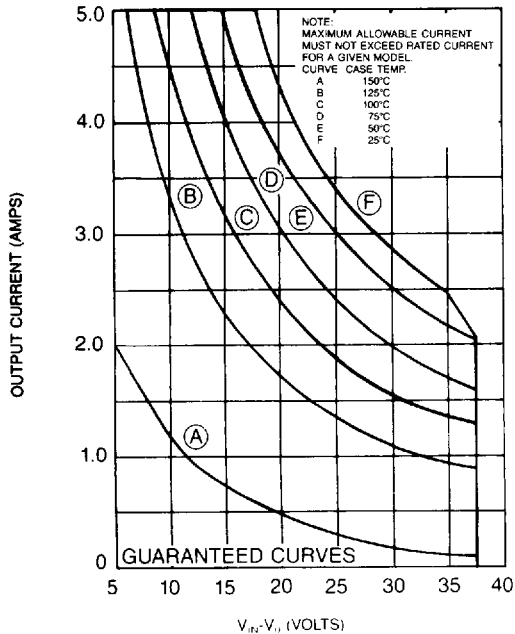

SAFE OPERATING AREA

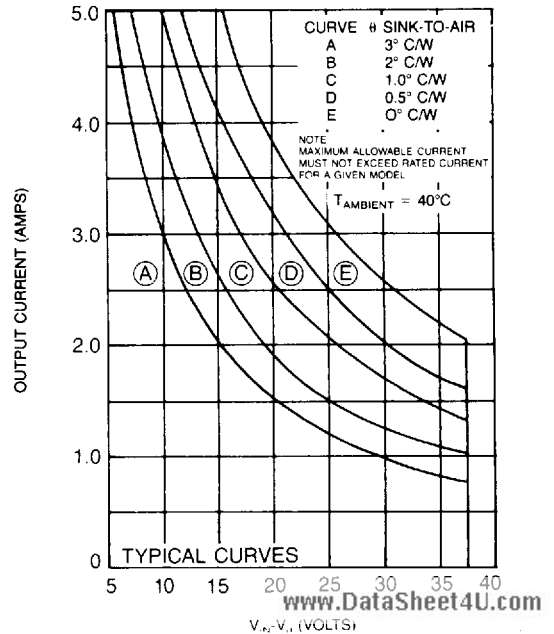

5 AMP, 85 WATT POSITIVE HYBRID VOLTAGE REGULATORS

DEVICE OUTLINE

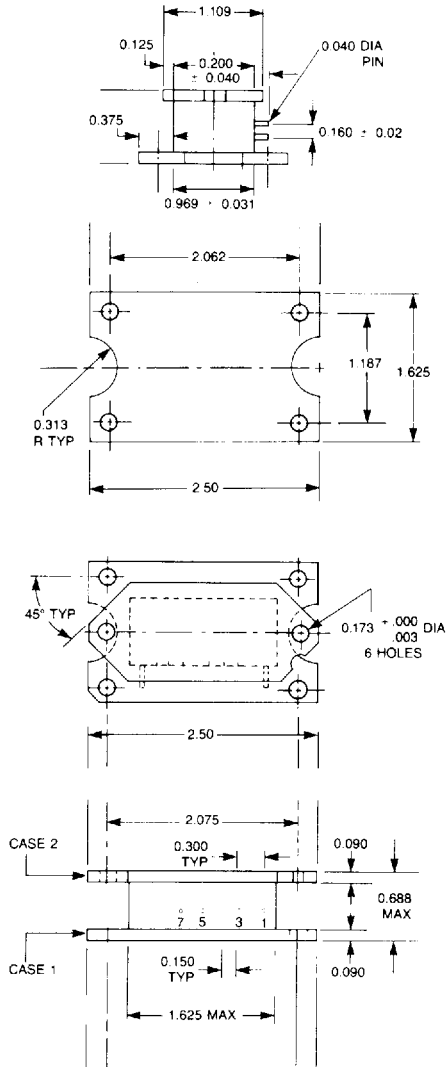

- | | | |
|---|-------|----------------|
| 1 | — (+) | Input Voltage |
| 3 | — (-) | Input Voltage |
| 5 | — (-) | Output Voltage |
| 7 | — (+) | Output Voltage |