

200mA PULSE WIDTH MODULATOR CONTROLLER

LAS-3840



FEATURES

- Dynamic volt/time balancing
- Cycle-by-cycle current limit
- Current limit frequency shift
- Programmable dead time
- Temperature compensated current limit

DESCRIPTION

The LAS 3840 is a high performance monolithic integrated circuit switching regulator designed for use in fixed frequency power control applications such as switching power supplies and motor controls. Included in the dual in-line hermetic & plastic packages are a temperature compensated voltage reference, under voltage lockout, sawtooth oscillator with over-current frequency shift, linear 'trailing edge' pulse width modulator with double pulse suppression logic, error amplifier, high speed current limit comparator, two push-pull output devices with over-current protection, shutdown logic and provision for dynamic volt-time symmetry correction in double ended systems. This circuit can be used to implement switching regulators of either polarity, transformer coupled DC to DC converters, transformerless voltage doublers, polarity converters, and DC/AC motor controls. The ceramic DIP device, LAS 3840, operates from -55°C to $+125^{\circ}\text{C}$. The Plastic DIP device, LAS 3840P, operates from 0°C to $+70^{\circ}\text{C}$.

ABSOLUTE MAXIMUM RATINGS

PARAMETER	SYMBOL	MAXIMUM	UNITS
Input Voltage	V_{IN}	40	Volts
Collector Supply Voltage	V_C	40	Volts
Source/Sink Current (per output)	I_O	200	mA
Thermal Resistance Junction to Ambient	θ_{JA}	125	$^{\circ}\text{C}/\text{Watt}$
Operating Junction Temperature Range LAS 3840 LAS 3840P	T_J	-55 to +125 0 to 70	$^{\circ}\text{C}$
Storage Temperature Range LAS3840 LAS 3840P	T_{STG}	-55 to +125 -25 to +125	$^{\circ}\text{C}$
Lead Temperature (Soldering, 10 Seconds)	T_{LEAD}	260	$^{\circ}\text{C}$

DEVICE SELECTION GUIDE

DEVICE	PACKAGE
LAS 3840	Ceramic DIP
LAS 3840P	Plastic DIP

BLOCK DIAGRAM

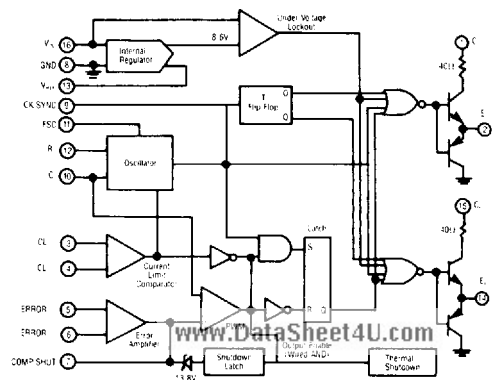

ELECTRICAL CHARACTERISTICS

Test conditions are as follows: $V_{IN} = 14$ Volts, $f = 40$ kHz, $T_J = -55^\circ\text{C}$ to 125°C (LAS 3840) or $T_J = 0^\circ\text{C}$ to 70°C (LAS 3840P), unless otherwise specified.

See test circuit.

Parameter	Test Conditions		Test Limits			Units
	V_{IN}	T_J	Minimum	Typical	Maximum	
REFERENCE SECTION						
Reference Output Voltage		25°C	1.56	1.65	1.74	Volts
Line Regulation	10V to 40V			0.005	0.028	%/V
Temperature Coefficient				0.002	0.006	%/°C
Output Resistance				5		k Ω
Output Noise Voltage ¹				50	200	μ Vrms
Long Term Stability				0.3		%
OSCILLATOR SECTION						
Frequency Initial Accuracy			-15	\pm 5	+15	%
Frequency Line Regulation	10V to 40V			0.005	0.039	%/ V_{IN}
Frequency Temperature Coefficient				-0.01	-0.025	%/°C
Maximum Frequency					400	kHz
Dead Time Initial Accuracy		25°C		-10		%
Dead Time Temperature Coefficient				+0.16		%/°C
Sawtooth Min/Max Voltage		25°C	1.2		2.4	Volts
Clock Amplitude				5.0		Volts
Clock Sync Threshold			2.0		5.0	Volts
Sync input Current				1		mA
Timing Capacitor			0.001		0.1	μ F
Timing Resistor			6.8		1000	k Ω
Frequency Shift			1.33	1.7	2.5	X
Frequency Shift Enable Voltage				0.8		Volts
ERROR AMPLIFIER SECTION						
DC Open Loop Gain			60	70		dB
Unity Gain Crossover Frequency				1.0		MHz
Slew Rate				1.0		V/ μ S
Input Bias Current				0.2		μ A
Input Offset Current				20		nA
Input Offset Voltage		25°C		\pm 10		mV
Input Common Mode Range			0		6	Volts
Output Common Mode Range			0.2		6	Volts
Output Source Current Limit				8		mA
Supply Ripple Rejection			60	70		dB
Minimum Output Pulse Width				0.8		μ S
Over Voltage Shutdown Threshold				13.8		Volts
CURRENT LIMIT COMPARATOR SECTION						
Threshold Voltage			0.6	0.7	0.8	Volts
Threshold Temperature Coefficient				0.025		%/°C
Input Common Mode Range			0		4	Volts
Input Bias Current				-0.3		mA
Time Delay to Outputs Off				0.3	0.5	μ S
OUTPUT SECTION						
Leakage Current				100	500	μ A
Maximum Source/Sink Current Peak Continuous					0.2 0.02	Amps
On State Voltage		$I_{SOURCE} = 0.02A$		3.5		Volts
Off State Voltage		$I_{SINK} = 0.02A$		1.1		Volts
Rise Time (Output Current) ²				0.2		μ S
Fall Time (Output Current) ²				0.1		μ S
UNDER VOLTAGE LOCKOUT SECTION						
Output Enable Threshold			8.3	8.8	9.4	Volts
Hysteresis				0.8	1	Volts
POWER CONSUMPTION						
Standby Current			10	15	30	mA
Operating Voltage Range ³			7		40	Volts

⁽¹⁾ BW = 10 - 10kHz

⁽²⁾ Measured with 0.001 μ F capacitor at CL + pin.

⁽³⁾ The device operates correctly in this range. Line effect changes from 7 to 15 volts are roughly equal to line effects from 10 to 40 volts.

200mA PULSE WIDTH MODULATOR CONTROLLER

LAS-3840

OPERATIONAL DATA

TEST CIRCUIT

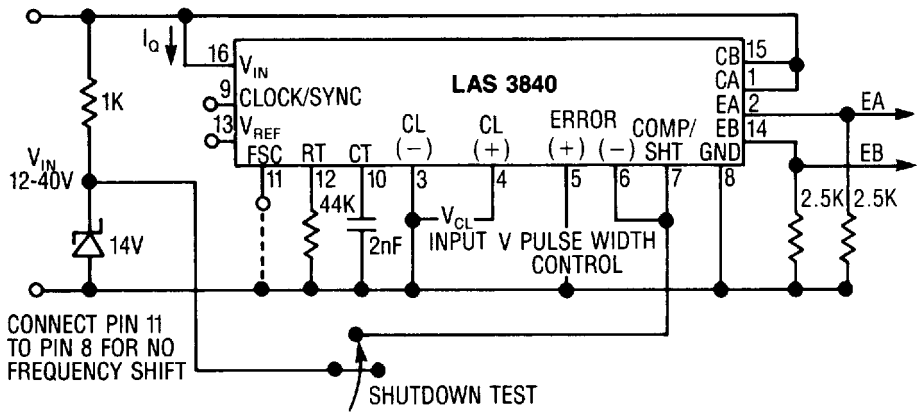

ERROR AMPLIFIER OPEN LOOP FREQUENCY RESPONSE

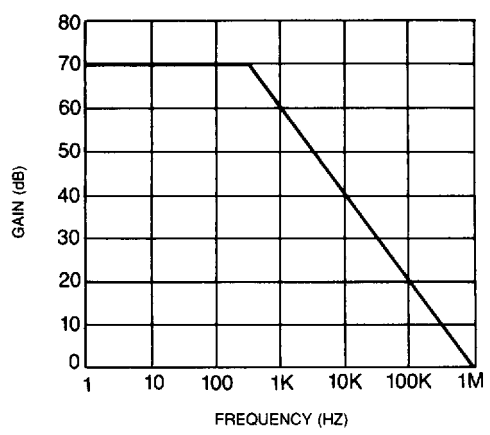

COMPONENT SELECTION

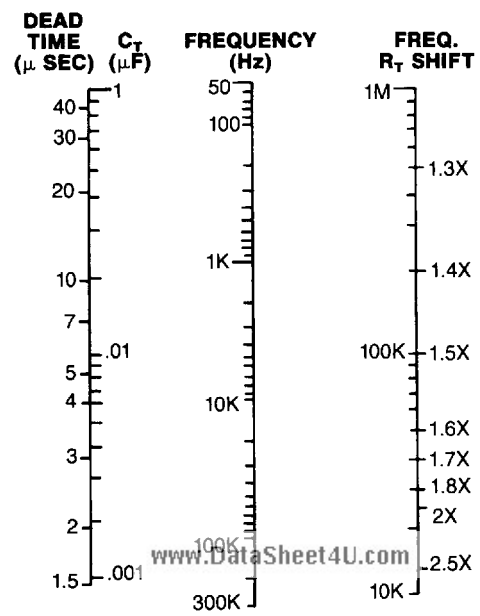

200mA PULSE WIDTH MODULATOR CONTROLLER

DEVICE OUTLINE

**LAS 3840
(CERAMIC)**

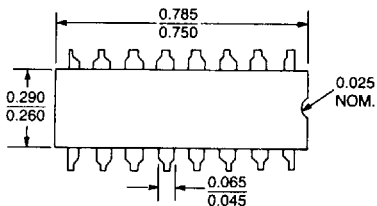

**LAS 3840P
(PLASTIC)**

