

## 8 AMP SWITCHING REGULATORS

T-58-11-31

### FEATURES

- DC to 100 kHz operation
- Adjustable output voltage
- Cycle-by-cycle current limit
- Internal thermal shutdown
- Inhibit/enable control pin

### ABSOLUTE MAXIMUM RATINGS

PARAMETER	SYMBOL	MAXIMUM	UNITS
Control Circuit Voltage	$V_{CC}$	35	Volts
Output Collector Voltage	$C_O$	35	Volts
Power Dissipation	$P_D$	Internally Limited	Watts
Thermal Resistance Junction to Case LAS 6380 & 6381 LAS 6380P1 & 6381P1	$\theta_{JC}$	1.5 0.8	$^{\circ}C/W$
Operating Junction and Storage Temperature Range	$T_J$ $T_{STG}$	- 25 to 125	$^{\circ}C$
Lead Temperature (Soldering) 60 sec for TO-3 10 sec for SIP	$T_{LEAD}$	300 260	$^{\circ}C$

### DESCRIPTION

The LAS 6380 Series are monolithic integrated circuits designed for fixed frequency, pulse width modulated, switching converter applications such as step-down, step-up, flyback, forward, Cuk and voltage inverting DC-to-DC converters and motor controls. The LAS 6380 Series includes a temperature compensated voltage reference, sawtooth oscillator with over-current frequency shift, linear trailing edge pulse width modulator with double pulse suppression logic, transconductance error amplifier, and an 8 amp Darlington output transistor with internal current limit protection.

The LAS 6380 & 6380P1 can be used in step-down or step-up applications. The LAS 6381 & LAS 6381P1 are for step-down applications where current limit adjustment is necessary. The LAS 6380 Series is available in TO-3 steel packages for true hermetic seal and board insertable plastic SIP packages.

### DEVICE SELECTION GUIDE

DEVICE	CURRENT LIMIT	PACKAGE
LAS 6380	Fixed	TO-3
LAS 6381	Adjustable	TO-3
LAS 6380P1	Fixed	Plastic SIP
LAS 6381P1	Adjustable	Plastic SIP

#### LAS6380

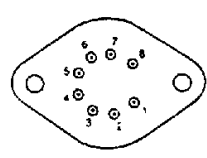

Bottom View

- 1 -  $C_O$
- 2 -  $V_{CC}$
- 3 -  $C_I$
- 4 - CNT
- 5 -  $V_{REF}$
- 6 -  $E_{rr}(-)$
- 7 - CMP
- 8 -  $E_O$
- Case is Ground

### BLOCK DIAGRAM

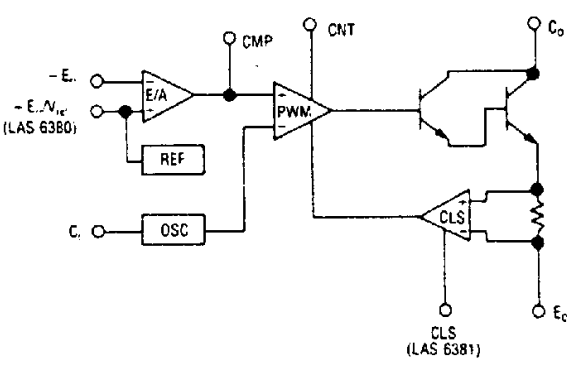

#### LAS6381

- 1 -  $C_O/V_{CC}$
- 2 -  $C_I$
- 3 - CNT
- 4 -  $V_{REF}$
- 5 -  $E_{rr}(-)$
- 6 - CMP
- 7 - CLS
- 8 -  $E_O$
- Case is Ground

#### LAS6380P1

- 1 -  $C_O$
- 2 -  $V_{CC}$
- 3 -  $C_I$
- 4 - CNT
- 5 - GND
- 6 -  $V_{REF}$
- 7 -  $E_{rr}(-)$
- 8 - CMP
- 9 -  $E_O$
- Tab is Ground

#### LAS6381P1

- 1 -  $C_O/V_{CC}$
- 2 -  $C_I$
- 3 - CNT
- 4 -  $V_{REF}$
- 5 - GND
- 6 -  $E_{rr}(-)$
- 7 - CMP
- 8 - CLS
- 9 -  $E_O$
- Tab is Ground

# ELECTRICAL CHARACTERISTICS

Test conditions are as follows:  $V_{CC} = 24V$ ,  $V_O = 5V$ ,  $I_O = 8A$ ,  $C_t = 0.0056\mu F$ ,  
 $T_J = 25^\circ C$ , unless otherwise specified.

Parameter	Symbol	Test Conditions			Test Limits			Units
		$V_{CC}$	$I_O$	$T_J$	Minimum	Typical	Maximum	
<b>REFERENCE SECTION</b>								
Reference Voltage	$V_{REF}$				2.137	2.25	2.363	Volts
Line Regulation	$REG_{(LINE)}$	12V to 30V				0.015	0.04	%/V
Temperature Coefficient	$T_C$			0 to 125°C		0.01	0.02	%/°C
<b>OSCILLATOR SECTION</b>								
Initial Frequency Accuracy					-33	± 10	+33	%
Line Regulation of Frequency	$REG_{(LINE)}$	12V to 30V				0.1	0.15	%/V
Frequency Temperature Coefficient	$T_C$			0 to 125°C		0.05		%/°C
Sawtooth Duty Cycle	d.c.					85		%
<b>ERROR AMPLIFIER SECTION</b>								
Input Offset Voltage						± 5		mV
Transconductance						2.7		mA/V
Output Sink/Source Current						0.26		mA
Input Common Mode Range					1.5		3.0	Volts
Open Loop Voltage Gain					50	60		dB
<b>OUTPUT SECTION</b>								
Peak Switching Current Limit	$I_{CL}$				9	11	13	Amps
Output Saturation Voltage	$V_O$ (sat)	$C_O = V_{CC}$ $C_O = V_{CC}$ $E_O = GND$ $E_C = GND$	4A 8A 4A 8A			1.6 2.1 0.9 1.4	2.5 1.8	Volts Volts Volts Volts
Efficiency	$\eta$				70	75		%
Current Rise Time	$t_R$	Inductive Load				50	100	nS
Current Fall Time	$t_F$	Inductive Load				700	900	nS
<b>CONTROL PIN</b>								
Output Inhibit					0.64	0.75	1.06	Volts
Quiescent Current	$I_O$	$V_O = 0V$				18	30	mA

# OPERATIONAL DATA

### POWER DERATING

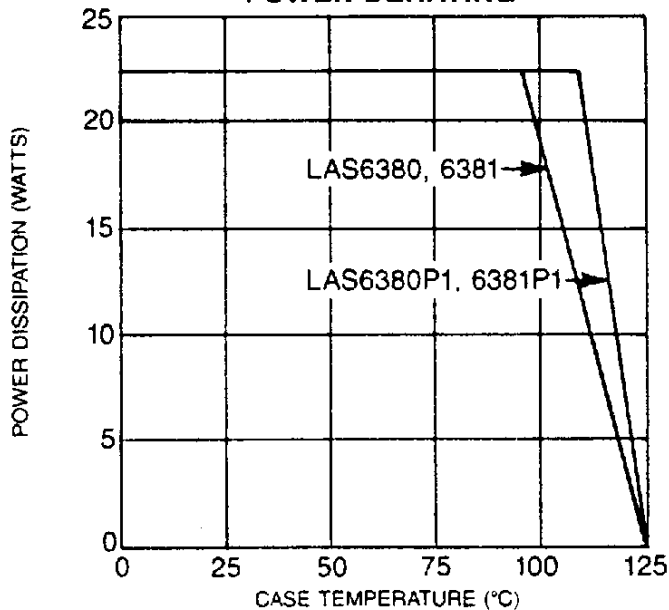

### POWER DISSIPATION VS INPUT VOLTAGE

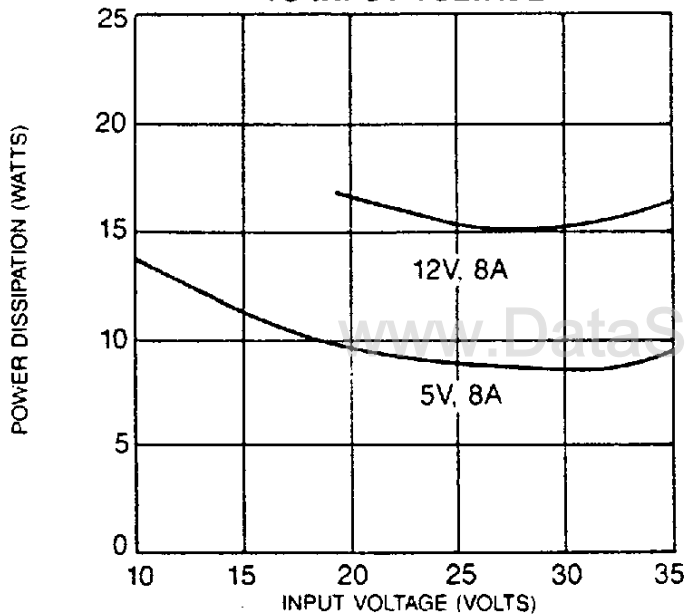

### EFFICIENCY VS INPUT VOLTAGE

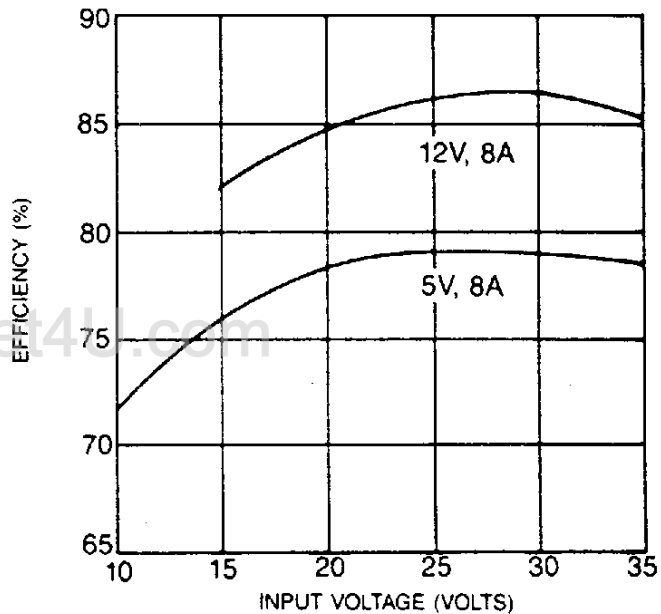

### FREQUENCY VS TIMING CAPACITANCE

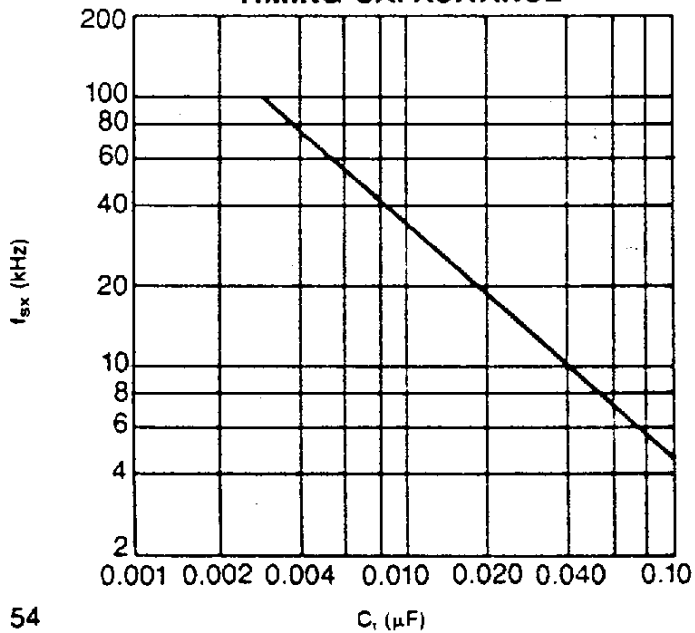

### ERROR AMPLIFIER OPEN LOOP GAIN

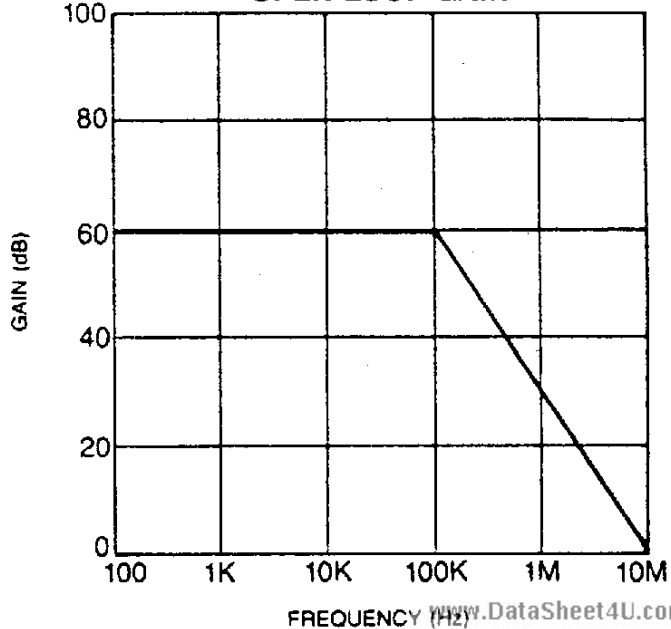

# TYPICAL APPLICATIONS

## DC-TO-DC STEP-DOWN CONVERTER

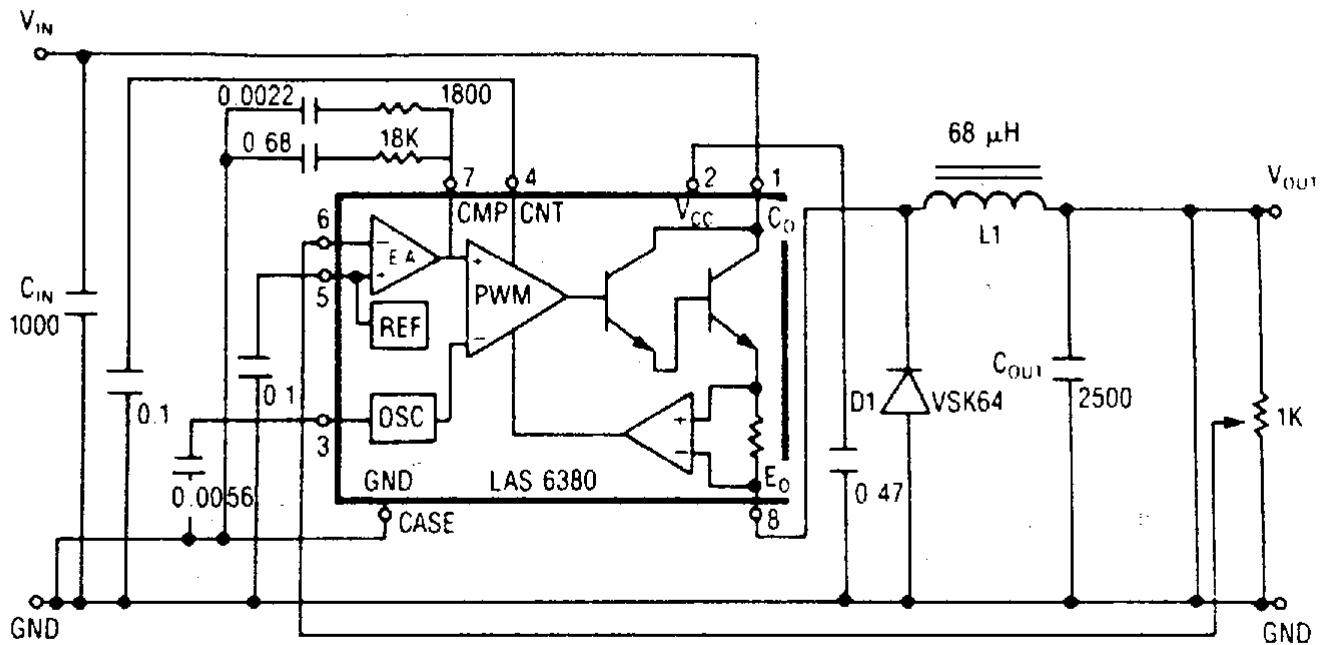

$$V_{IN} = 24V$$

$$V_{OUT} = 5V @ 8A$$

www.DataSheet4U.com

## DC-TO-DC STEP-UP CONVERTER

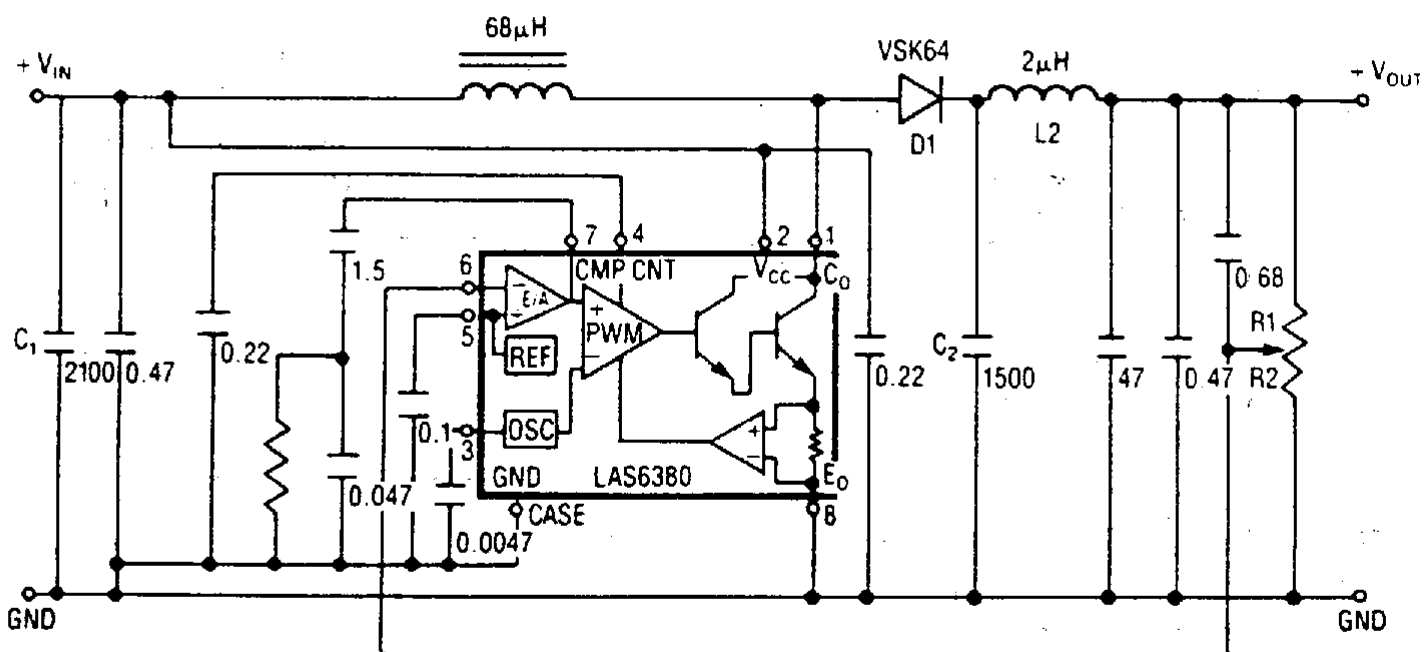

$$V_{IN} = 12V$$

$$V_{OUT} = 24V @ 2.5A$$

www.DataSheet4U.com

# DEVICE OUTLINE

**LAS6380, 6381**

**LAS6380P1, 6381P1**

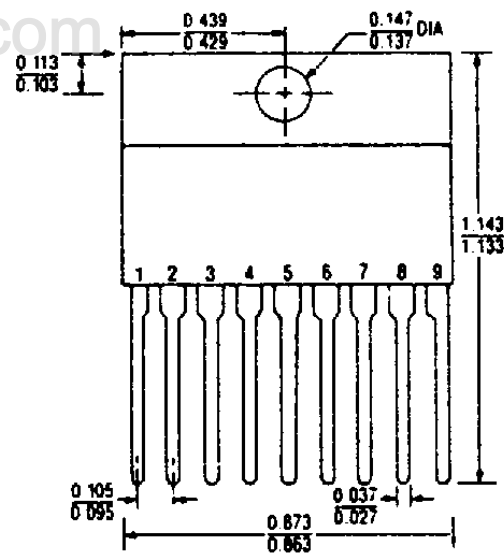
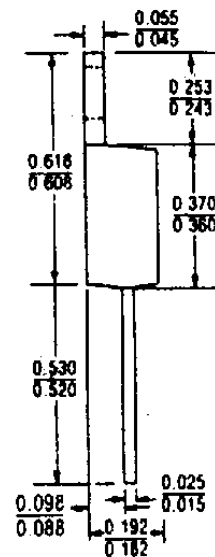
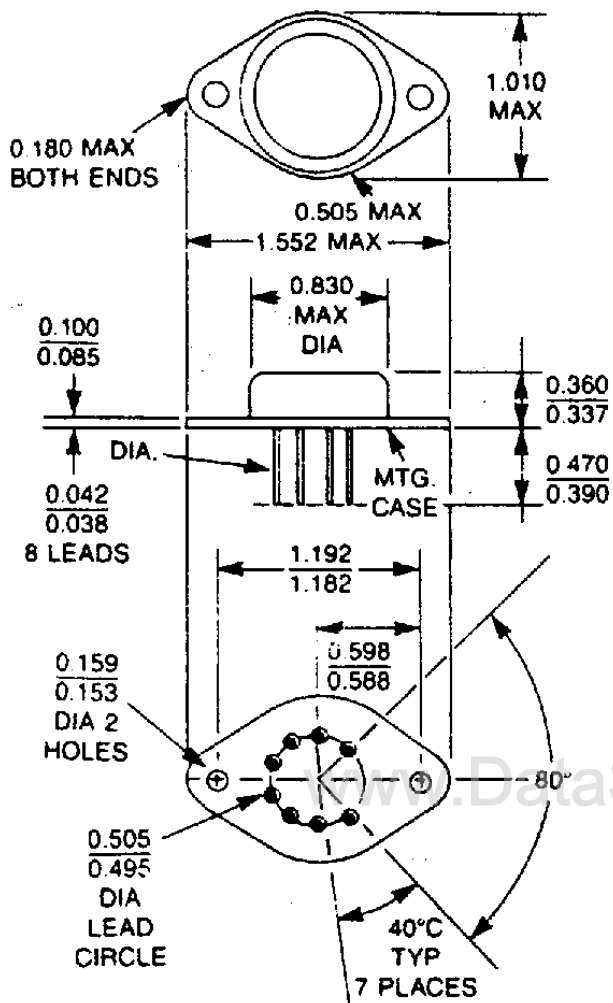

**Front View**

NOTE: All dimensions are in inches.