

Product Specification**Contents**

No.	Item	Page
0	Record of Revisions	3
1	General Description	4
2	Interface Connection	6
3	Absolute Maximum Ratings	8
4	Electrical Characteristics	9
5	Optical Characteristics	15
6	Mechanical Characteristics	18
7	Color Input Data Reference	19
8	Reliability Test	20
9	Outline Dimension	21
10	Packing	22
11	Precautions	23

Product Specification

1. General Description

1-1. Description

The LB050WQ2-TD01 is a **White LED Backlight Assembly** product of TFT LCD without any extra system. This module utilizes amorphous silicon thin film transistors. A 5.0" active matrix liquid crystal display allows 16M colors to be displayed. The applications are portable DVD, car navigation, multimedia applications and others AV system.

1-2. Features

- High brightness & contrast ratio
- Wide viewing angle
- WQVGA(480X272 pixels) resolution
- 8 bits color depth
- T-Con & power block is built In D-IC
- Low power consumption
- DE (Data Enable) only mode – DE, DOTCLK

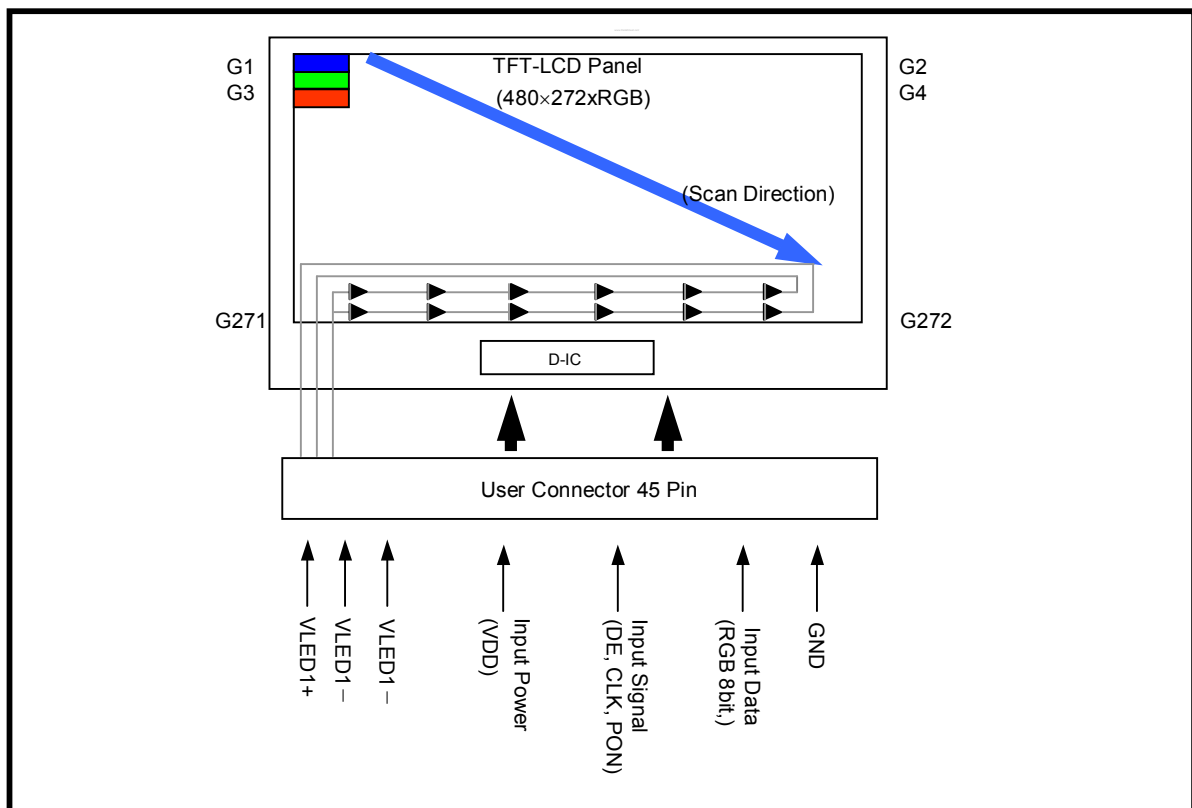

Product Specification

1-3. General Specification

PARAMETER	SPECIFICATION	REMARK
Active Screen Size	5.0 inches	Diagonal
Outline Dimension	124[H] x 77.2[V] x 3.35[D]	[mm]
Active Area	110.736[H] x 62.424[V]	[mm]
Number of dots	480[H] x 272 x RGB[V]	-
Dot Pitch	0.2307 x 0.2295	[mm]
Display Mode	TN / Transmissive / Normally White	-
Viewing Direction	6 o'clock	12 o'clock (good viewing)
Color Filter Array	RGB Horizontal Stripe	-
Signal Interface	Digital RGB	-
Weight	70	[g]
Backlight	12LEDs	-

Product Specification

2. Interface Connections

This LCD employs one interface connection for the operation of module. The pin configuration for the connector is shown in the table below.

2-1. Main LCM Connector

(Connector Type: 45Pin 0.5mm pitch,

Mating Connector: Hirose FH12 Series)

Pin	Symbol	Description	I/O	Remark
1	VSS	GROUND	I	
2	VSS	GROUND	I	
3	VDD	POWER SUPPLY	I	[Notes 2-1]
4	VDD	POWER SUPPLY	I	
5	R0	RED DATA(LSB)	I	
6	R1	RED DATA	I	
7	R2	RED DATA	I	
8	R3	RED DATA	I	
9	R4	RED DATA	I	
10	R5	RED DATA	I	
11	R6	RED DATA	I	
12	R7	RED DATA(MSB)	I	
13	G0	GREEN DATA(LSB)	I	
14	G1	GREEN DATA	I	
15	G2	GREEN DATA	I	
16	G3	GREEN DATA	I	
17	G4	GREEN DATA	I	
18	G5	GREEN DATA	I	
19	G6	GREEN DATA	I	
20	G7	GREEN DATA(MSB)	I	
21	B0	BLUE DATA(LSB)	I	
22	B1	BLUE DATA	I	
23	B2	BLUE DATA	I	
24	B3	BLUE DATA	I	
25	B4	BLUE DATA	I	
26	B5	BLUE DATA	I	
27	B6	BLUE DATA	I	
28	B7	BLUE DATA(MSB)	I	
29	VSS	GROUND	I	
30	DCLK	DATA CLOCK	I	

Product Specification

Pin	Symbol	Description	I/O	Remark
31	PON	DISPLAY ON/OFF	I	
32	NC	NO CONNECT	I	
33	NC	NO CONNECT	I	
34	DE	DATA ENABLE	I	
35	PWRSEL	VDD POWER SELECT	I	HIGH: 3.3V LOW : 2.5V
36	VSS	GROUND	I	
37	NC	NO CONNECT	I	
38	NC	NO CONNECT	I	
39	NC	NO CONNECT	I	
40	NC	NO CONNECT	I	
41	VSS	GROUND	I	
42	LED-	LED_CATHODE	I	
43	LED-	LED_CATHODE	I	
44	LED+	LED_ANODE	I	
45	NC	NO CONNECT	I	

[Note 2-1] VDD Voltage could be changed by PWRSEL.
PWRSEL is High → VDD Voltage must be 3.3V
PWRSEL is Low → VDD Voltage must be 2.5V

Product Specification

3. Absolute Maximum Ratings

If used the beyond absolute maximum ratings, this device can permanently be damaged.
 It is strongly recommended to use this device at a condition for normal operation.

Parameter	Symbol	CONDITION	Min	Max	Unit	Notes
Power Supply Voltage	VDD	T _a =25℃	-0.3	4.6	V	
LED Forward Current	I _f	T _a =25℃	-	30	mA	[Note 3-1]
Operating Temperature	T _{op}	-	-20	70	℃	[Note 3-2]
Storage Temperature	T _{st}	-	-30	80	℃	[Note 3-2]

[Note 3-1] Applies for each LED individually

[Note 3-2] If fixed pattern is displayed for a minutes, Image Sticking may appear.

[Note 3-3] Temp. ≤ 60℃, Humidity 95% RH Max

Temp. > 60℃, Absolute humidity shall be less than 95% RH at 60℃.

No condensation > 40℃

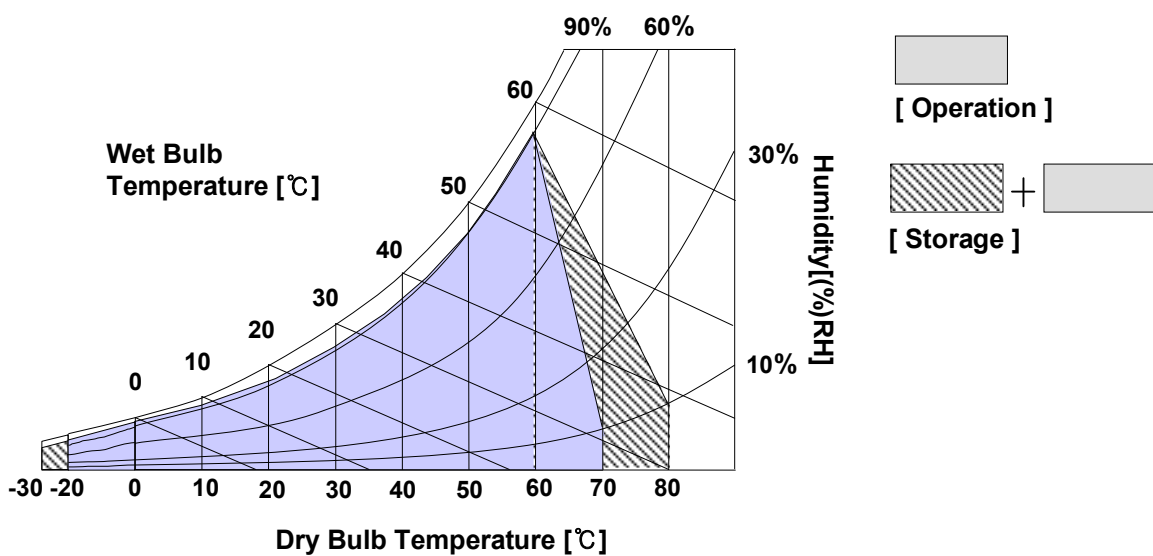

Product Specification
4. Electrical Characteristics
4-1. Recommended Operating Conditions

◆ TFT-LCD Panel Driving Section

 ($T_a = 25^\circ C$)

PARAMETER	SYMBOL	MIN.	TYP.	MAX.	UNIT	REMARK
Digital Input Voltage	VDD	2.3	2.5	2.8	V	PWRSEL=0
		2.9	3.3	3.5	V	PWRSEL=1
Frame Frequency	fFRAME		60		Hz	
Dot Clock	fclk		9.0	15.0	MHz	
Logic Input Voltage	V_{IH}	0.7*VDD	-	VDD	V	
	V_{IL}	0	-	0.3*VDD	V	
Logic Output Voltage	V_{OH}	VDD-0.4	-	VDD	V	
	V_{OL}	0	-	0.4	V	
Power Consumption	-		100	120	mW	White
			120	140	mW	Black

[Note4-1] PWRSEL = LOW

[Note4-2] PWRSEL = High

4-2. Backlight Unit

 ($T_a = 25^\circ C$)

PARAMETER	SYMBOL	MIN.	TYP.	MAX.	UNIT	REMARK
LED forward Current	I_f	-	20	-	mA	[Note4-3]
Power Consumption	P_{BL}	-	770	-	mW	

[Note4-3] The permissible forward current of LED vary with environmental temperature.

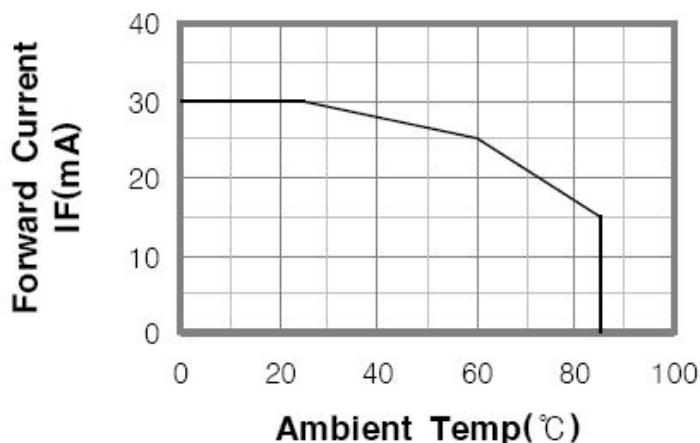

Product Specification

4-3. Timing Characteristics of input signals

(T_a = 25° C)

PARAMETER	SYMBOL	Min.	Typ.	Max.	Unit	
DOTCLK Cycle	f _{DOTCLK}	-	9.2	15.0	MHz	
Frame Frequency	f _{FRM}	-	60	70	Hz	
Frame Period	VCYC	277	286	335	H	
Vertical Blank Period	VBLP	5	14	63	H	
Vertical Display Period	VDP	277	272	272	H	
Line Period	HCYC	490	525	605	CLK	
Horizontal Blank Period	HBLP	10	45	125	CLK	
Horizontal Display Period	HDP	480	480	480	CLK	

[Note] If a driving condition is not in specification, then the LCM could be operate inappropriately.

Product Specification

4-4. RGB Data Interface Timing Figure

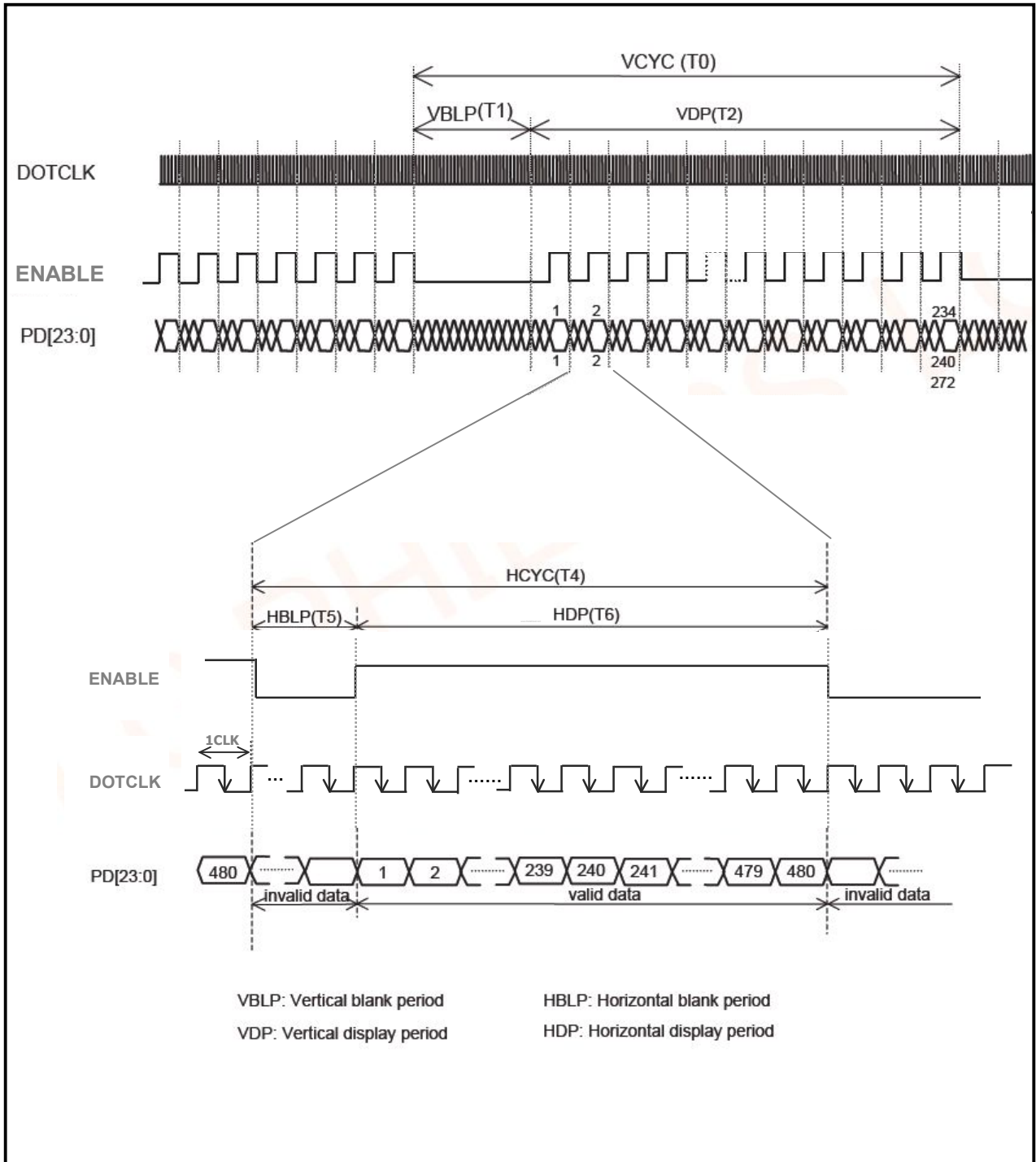

Product Specification

4-5. Clock Synchronized Characteristics

PARAMETER	SYMBOL	Min.	Typ.	Max.	Unit
Enable(DE) Setup time	t_{ENS}	10			ns
Enable(DE) hold time	t_{ENH}	10			ns
DOTCLK(MCLK) "Low" level Pulse width	PW_{DL}	25			ns
DOTCLK(MCLK) "High" level pulse	PW_{DH}	25			ns
DOTCLK(MCLK) cycle time	t_{CYCD}	66.7			ns
Data setup time	t_{PDS}	10			ns
Data hold time	t_{PDH}	10			ns
DOTCLK(MCLK), VSYNC, HSY NC, clock rise/fall time	t_{rgr}, t_{rgf}			5	ns

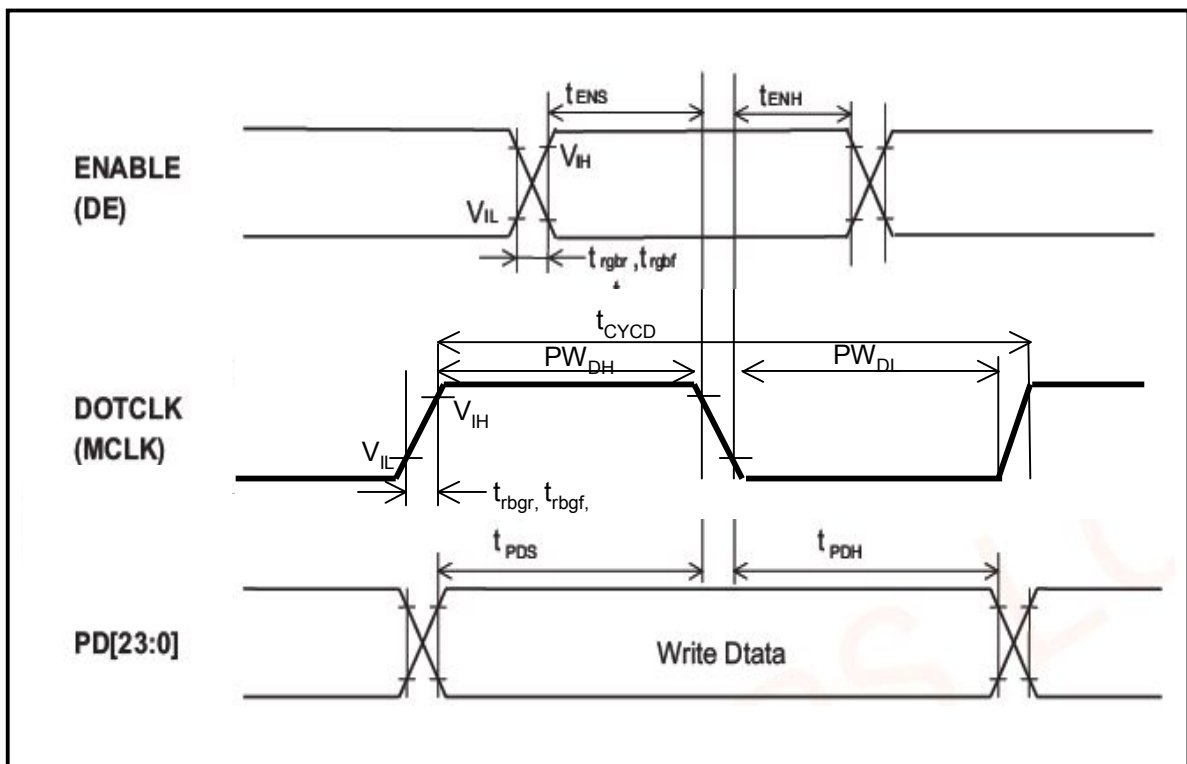

Product Specification

4-6. Pon Timing Characteristics

Item	Symbol	Min.	Typ.	Max.	Unit
Pon setup (DE mode)	t_{PONSE}	-	-	4	Line

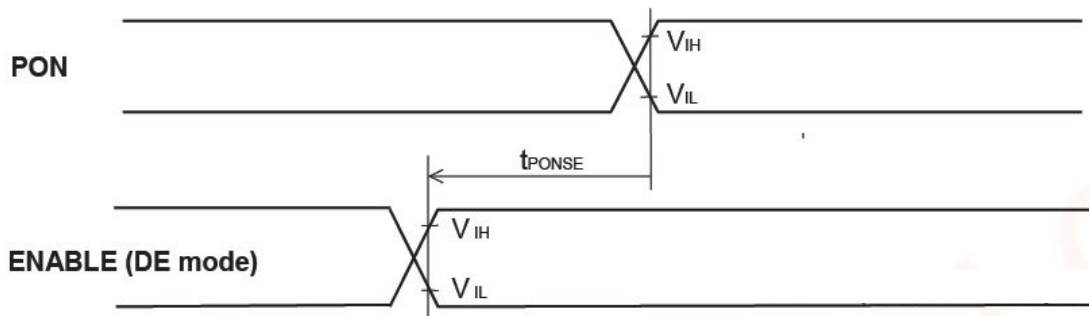

Product Specification

4-7. Power On/Off Sequence

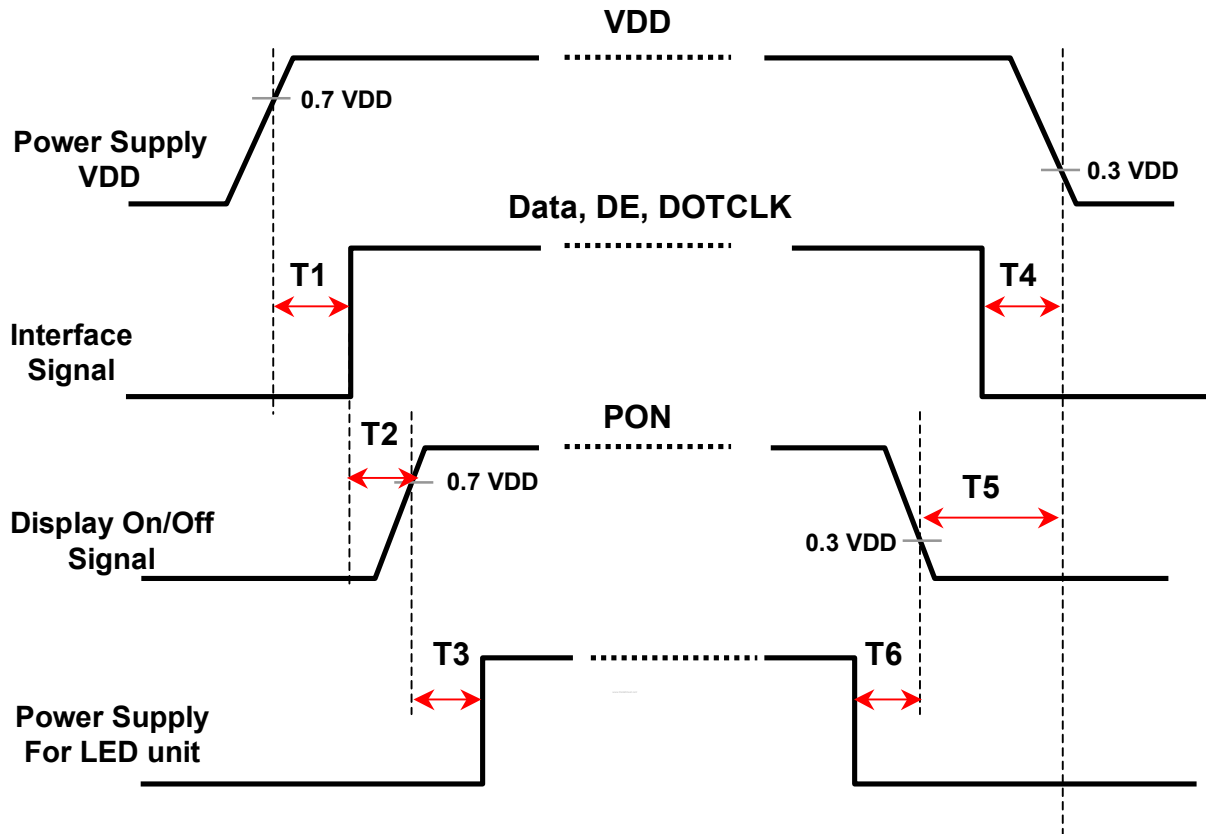

Symbol	Specifications	Note
T1	10ms < T1	
T2	10ms < T2 < 20ms	[Note4-5]
T3	160ms < T3	
T4	10ms < T4	
T5	(80ms + T4) < T5	[Note4-5]
T6	160ms < T6	

[Note4-5] Refer to “4-6. Pon Timing Characteristics.”

Product Specification

5. Optical Characteristics

5-1. TFT LCD Module

($T_a = 25^\circ C$)

PARAMETER		SYMBOL	CONDITION	MIN.	TYP.	MAX.	UNIT	REMARK
Luminance		Y	$I_{BL}=20mA$		500	-	cd/m ²	
Contrast Ratio		CR	Optimal	200	500	-	-	[Note5-2]
Viewing Angle	Hor.	θ_L	CR > 10	-	65	-	Degrees	[Note5-2] [Note5-3] PR-880
		θ_R		-	65	-		
	Ver.	θ_U		-	50	-		
		θ_D		-	60	-		
Response Time	Rising	$T_r + T_f$	$\theta = 0^\circ$	-	25	35	msec	[Note5-4] PR-880
	Falling							
White Color Chromaticity		Wx	Center	0.276	0.326	0.376	-	[Note5-1] PR-650
		Wy	Center	0.316	0.366	0.416		
		Rx	Center	0.519	0.569	0.619		
		Ry	Center	0.294	0.344	0.394		
		Gx	Center	0.297	0.347	0.397		
		Gy	Center	0.546	0.596	0.646		
		Bx	Center	0.115	0.165	0.215		
		By	Center	0.100	0.150	0.200		
Luminance Uniformity		U	$I_{BL}=20mA$	-	1.40	1.60	-	[Note5-5]

▪ Measurement condition : Refer to the below “Test Equipment Set Up” and next page.

[Test Equipment Set Up]

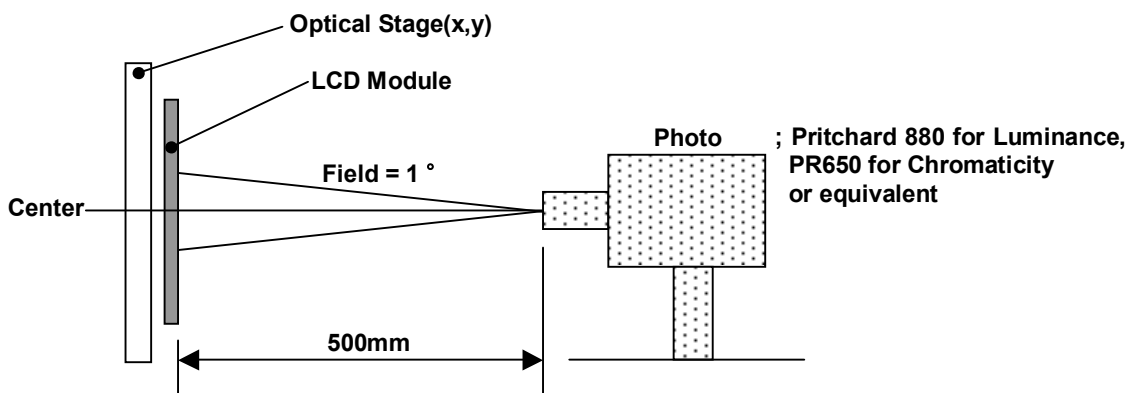

- Measuring Condition ;
 - Measuring surroundings : Dark Room
 - Measuring temperature : $T_a=25^\circ C$
 - Adjust operating voltage to get optimum contrast at the center of the display.
 - Measured value at the center point of LCD panel after more than 30 minutes while backlight turning on.

Product Specification

[Note 5-1]

Measured on the center area of the panel by PHOTO RESEARCH photometer PR-880&PR650 or Equivalent

[Note 5-2]

Contrast ratio is defined as follows ;

$$\text{Contrast Ratio(CR)} = \frac{\text{Photo detector output with LCD being "white"}}{\text{Photo detector output with LCD being "black"}}$$

[Note 5-3]

Viewing angle range is defined as follows [PR-880];

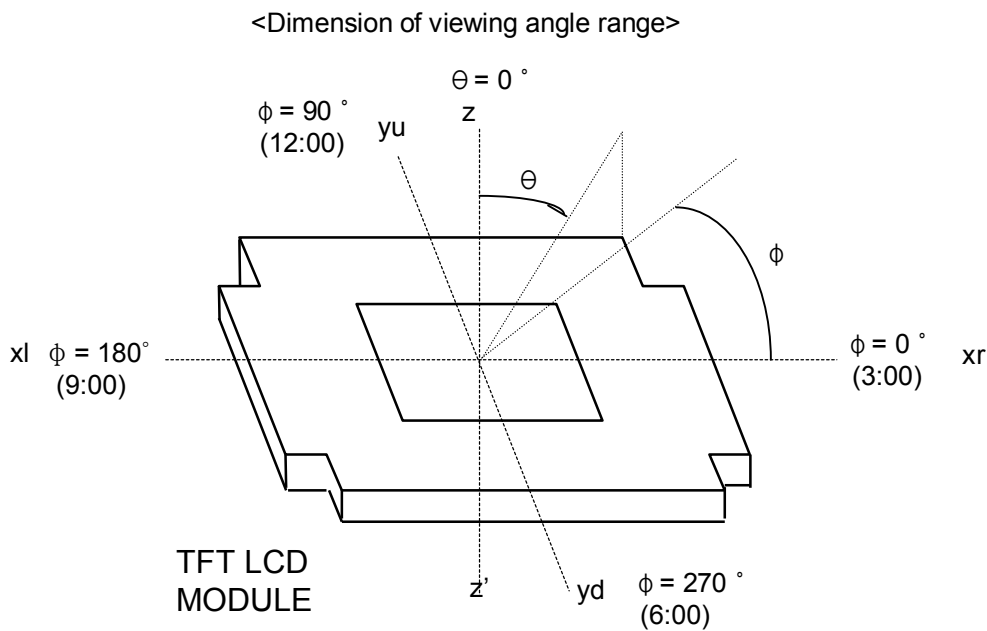

Product Specification

[Note 5-4]

Response time is obtained by measuring the transition time of photo detector output, when input signals are applied so as to make the area "black" to and from "white".

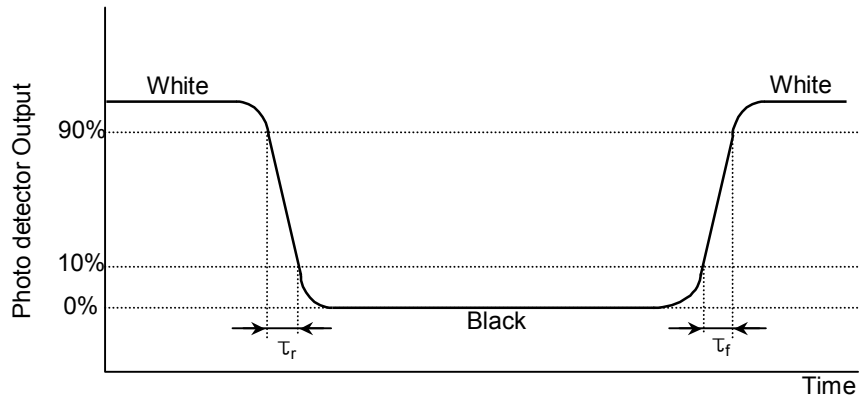

[Note 5-5]

Luminance Uniformity = Maximum of 9points (①~⑨) / Minimum of 9points (①~⑨)
 Luminance Uniformity(%) = Minimum of 9points (①~⑨) / Maximum of 9points (①~⑨) x 100

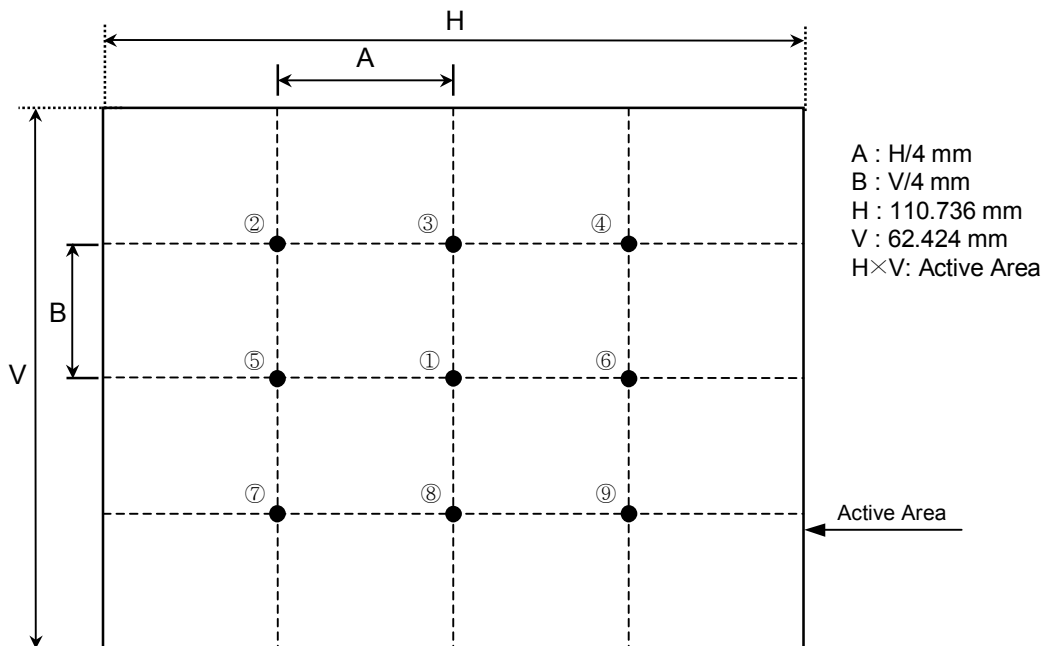

Product Specification

6. Mechanical Characteristics

Parameter	Specification		Unit	Notes
Outline Dimension	Horizontal	124(± 0.2)	mm	
	Vertical	77.2(± 0.2)	mm	
	Depth	3.35 ± (0.2)	mm	
Active Display Area	Horizontal	110.736	mm	
	Vertical	62.424	mm	
Weight	70		g	
Surface Treatment	Anti-Glare Treatment		-	

Product Specification

9. Outline Dimension

9-1. Front View

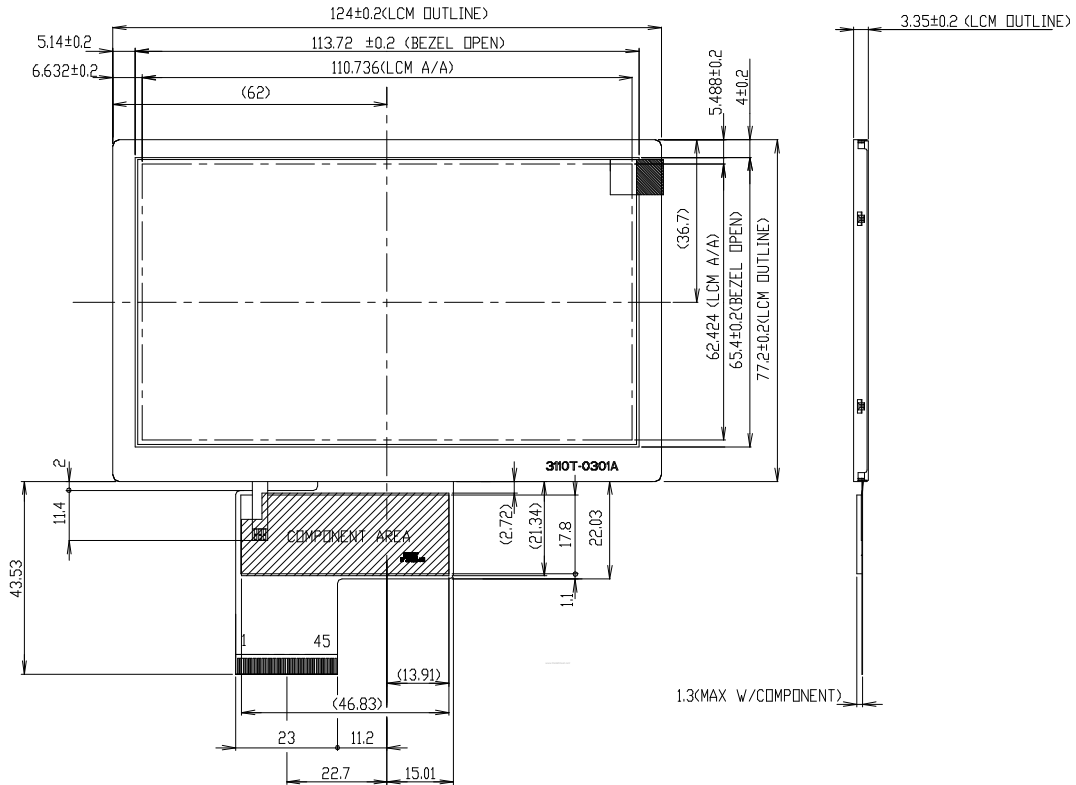

9-2. Rear View

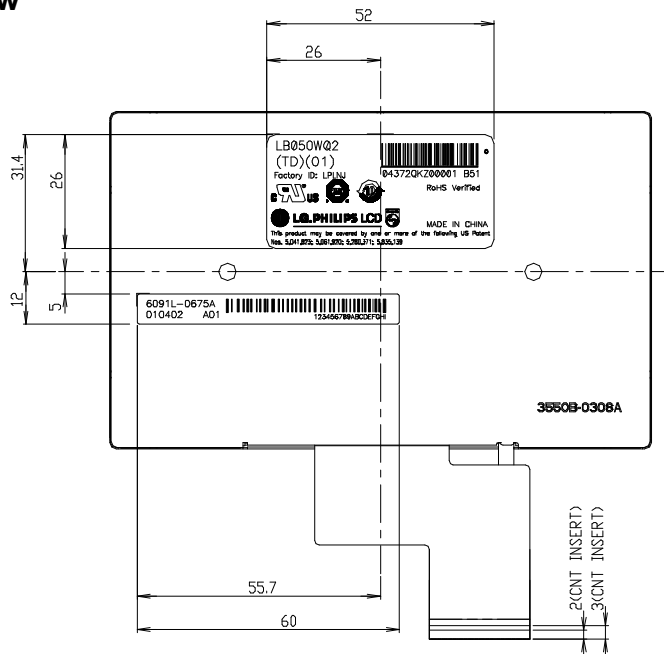

Product Specification

10. Packing

10-1. Packing Form

- a) Package quantity in one box : 96 pcs
- b) Box Size : 475X348X175 (mm)

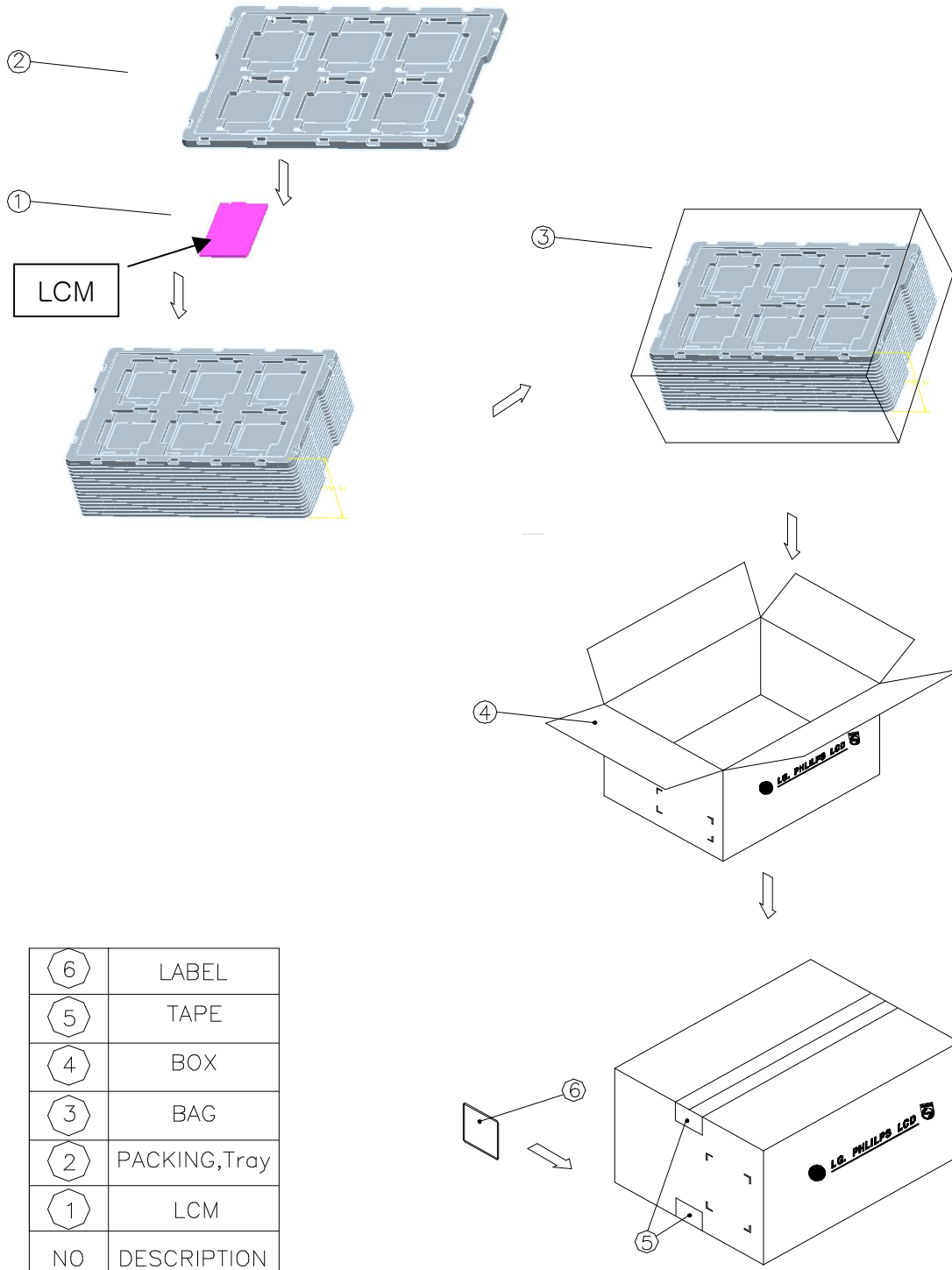

Product Specification

11. Precautions

Please pay attention to the following when you use this TFT LCD module.

11-1. Mounting Precautions

- (1) You should consider the mounting structure so that uneven force(ex. Twisted stress) is not applied to the module.
And the case on which a module is mounted should have sufficient strength so that external force is not transmitted directly to the module.
- (2) Please attach a transparent protective plate to the surface in order to protect the polarizer.
Transparent protective plate should have sufficient strength in order to resist external force.
- (3) You should adopt radiation structure to satisfy the temperature specification.
- (4) Acetic acid type and chlorine type materials for the cover case are not desirable because the former generates corrosive gas of attacking the polarizer at high temperature and the latter causes circuit break by electro-chemical reaction.
- (5) Do not touch, push or rub the exposed polarizers with glass, tweezers or anything harder than HB pencil lead. And please do not rub with dust clothes with chemical treatment.
Do not touch the surface of polarizer for bare hand or greasy cloth.(Some cosmetics deteriorate the polarizer.)
- (6) When the surface becomes dusty, please wipe gently with absorbent cotton or other soft materials like chamois soaks with petroleum benzene. Normal-hexane is recommended for cleaning the adhesives used to attach front / rear polarizers. Do not use acetone, toluene and alcohol because they cause chemical damage to the polarizer.
- (7) Wipe off saliva or water drops as soon as possible. Their long time contact with polarizer causes deformations and color fading.
- (8) The metal case of a module should be contacted to electrical ground of your system.

11-2. Operating Precautions

- (1) The spike noise causes the mis-operation of circuits. It should be lower than following voltage :
 $V = \pm 200\text{mV}$ (Over and under shoot voltage)
- (2) Response time depends on the temperature.(In lower temperature, it becomes longer.)
- (3) Brightness depends on the temperature. (In lower temperature, it becomes lower.)
And in lower temperature, response time(required time that brightness is stable after turned on) becomes longer.
- (4) Be careful for condensation at sudden temperature change. Condensation makes damage to polarizer or electrical contacted parts. And after fading condensation, smear or spot will occur.
- (5) When fixed patterns are displayed for a long time, remnant image is likely to occur.
- (6) Module has high frequency circuits. Sufficient suppression to the electromagnetic interference shall be done by system manufacturers. Grounding and shielding methods may be important to minimize the interference.

Product Specification

11-3. Electrostatic Discharge Control

Since a module is composed of electronic circuits, it is not strong to electrostatic discharge. Make certain that treatment persons are connected to ground through wrist band etc. And don't touch interface pin directly.

11-4. Precautions for Strong Light Exposure

Strong light exposure causes degradation of polarizer and color filter.

11-5. Storage

When storing modules as spares for a long time, the following precautions are necessary.

- (1) Store them in a dark place. Do not expose the module to sunlight or fluorescent light. Keep the temperature between 5°C and 35°C at normal humidity.
- (2) The polarizer surface should not come in contact with any other object.
It is recommended that they be stored in the container in which they were shipped.

11-6. Handling Precautions for Protection Film

- (1) When the protection film is peeled off, static electricity is generated between the film and polarizer.
This should be peeled off slowly and carefully by people who are electrically grounded and with well ion-blown equipment or in such a condition, etc.
- (2) The protection film is attached to the polarizer with a small amount of glue. If some stress is applied to rub the protection film against the polarizer during the time you peel off the film, the glue is apt to remain on the polarizer.
Please carefully peel off the protection film without rubbing it against the polarizer.
- (3) When the module with protection film attached is stored for a long time, sometimes there remains a very small amount of glue still on the polarizer after the protection film is peeled off.
- (4) You can remove the glue easily. When the glue remains on the polarizer surface or its vestige is recognized, please wipe them off with absorbent cotton waste or other soft material like chamois soaked with normal-hexane.