

Product Specification

# SPECIFICATION FOR APPROVAL

- (●) Preliminary Specification
- ( ) Final Specification

Title	6.4" VGA TFT LCD
-------	------------------

BUYER	
MODEL	

SUPPLIER	LG.Philips LCD CO., Ltd.
*MODEL	LB064V02
SUFFIX	A1

\*When you obtain standard approval, please use the above model name without suffix

SIGNATURE	DATE
/	_____
/	_____
/	_____

Please return 1 copy for your confirmation with your signature and comments.

APPROVED BY	DATE
C. S. Kyoung    G.Manager	_____
<b>REVIEWED BY</b>	
H.J. Kim    Manager	_____
<b>PREPARED BY</b>	
Y. T. Woo Research Engineer	_____

**Product Engineering Dept.**  
**LG. Philips LCD Co., Ltd**

**Product Specification**

<b>NO.</b>	<b>ITEM</b>	<b>Page</b>
-	COVER	1
-	CONTENTS	2
-	RECORD OF REVISIONS	3
1	GENERAL DESCRIPTION	4
2	ABSOLUTE MAXIMUM RATINGS	5
3	ELECTRICAL SPECIFICATIONS	6
3-1	ELECTRICAL CHARACTERISTICS	6
3-2	INTERFACE CONNECTIONS	8
3-3	SIGNAL TIMING SPECIFICATIONS	9
3-4	SIGNAL TIMING WAVEFORMS	10
3-5	COLOR INPUT DATA REFERENCE	11
3-6	POWER SEQUENCE	12
4	OPTICAL SPECIFICATIONS	13
5	MECHANICAL CHARACTERISTICS	17
6	RELIABILITY	21
7	INTERNATIONAL STANDARDS	22
7-1	SAFETY	22
7-2	EMC	22
8	PACKING	23
8-1	DESIGNATION OF LOT MARK	23
8-2	PACKING FORM	23
9	PRECAUTIONS	24

Product Specification

**RECORDS OF REVISIONS**

Revision No	Revision No	Page	DESCRIPTION
1.0	DEC 20,2002	-	● First Draft

Product Specification

1. General Description

The LB064V02-A1 is a Color Active Matrix Liquid Crystal Display with an integral Cold Cathode Fluorescent Lamp(CCFL) backlight system. The matrix employs a-Si Thin Film Transistor as the active element. It is a transmissive type display operating in the normally white mode. This TFT-LCD has 6.4 inches diagonally measured active display area with VGA resolution(480 vertical by 640 horizontal pixel array) Each pixel is divided into Red, Green and Blue sub-pixels or dots which are arranged in vertical stripes. Gray scale or the brightness of the sub-pixel color is determined with a 6-bit gray scale signal for each dot, thus, presenting a palette of more than 262,144 colors.

The LB064V02-A1 has been designed to apply the interface method that enables low power, high speed, low EMI. The LB064V02-A1 is intended to support applications where thin thickness, low power are critical factors and graphic display are important. In combination with the vertical arrangement of the sub-pixels, the LB064V02-A1 characteristics provide an excellent flat display for office automation products such as portable Computer and FA.

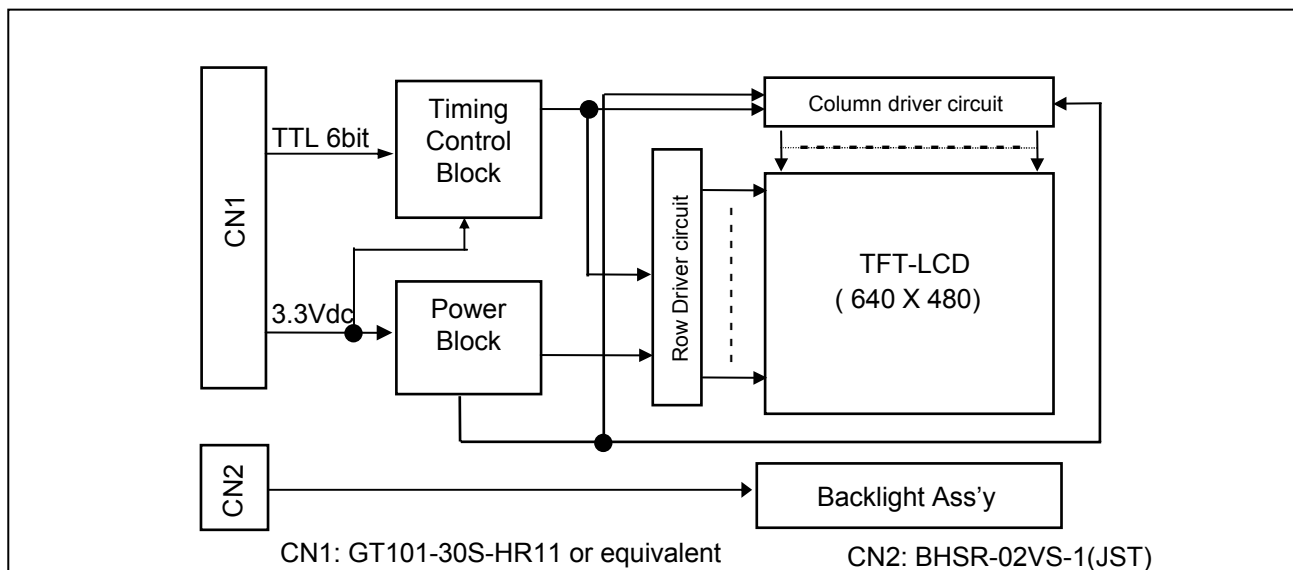

General Features

Active screen size	6.4 inches (163.2mm) diagonal
Outline Dimension	145.5(H) x 111.5(V) x 6.0(D) mm(Typ.)
Pixel Pitch	0.204 mm x 0.204mm
Pixel format	640 horiz. By 480 vert. Pixels RGB stripes arrangement
Color depth	6-bit, 262,144 colors
Luminance, white	250 cd/m <sup>2</sup> (Typ.)
Power Consumption	TBD
Weight	160g(Typ.)
Display operating mode	Transmissive mode, Normally white
Surface treatments	Hard coating(3H) Anti-glare treatment of the front polarizer, HAZE(13%)

Product Specification

2. Absolute Maximum Ratings

The following are maximum values which, if exceeded, may cause faulty operation or damage to the unit.

Table 1. ABSOLUTE MAXIMUM RATINGS

Parameter	symbol	Values		Units	Notes
		Min.	Max.		
Power Input Voltage	V <sub>CC</sub>	-0.3	4.0	Vdc	At 25 ± 5°C
Operating Temperature	T <sub>OP</sub>	0	50	°C	1
Storage Temperature	T <sub>ST</sub>	-20	60	°C	1
Operating Ambient Humidity	H <sub>OP</sub>	10	90	%RH	1
Storage Humidity	H <sub>ST</sub>	10	90	%RH	1

Note : 1. Temperature and relative humidity range are shown in the figure below.  
Wet bulb temperature should be 39 °C Max, and no condensation of water.

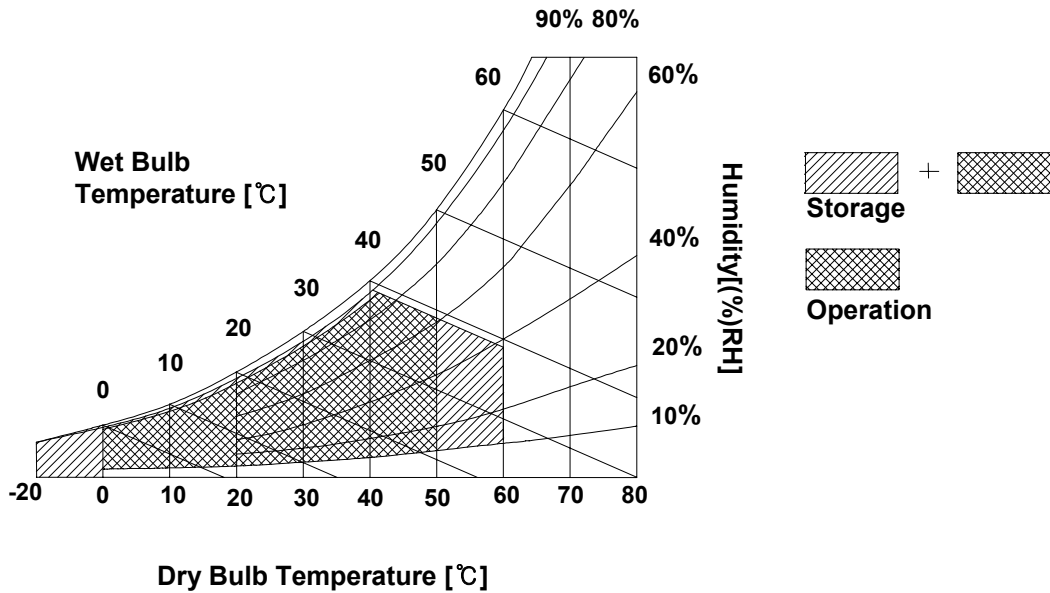

**Product Specification**
**3. Electrical Specifications**
**3-1. Electrical Characteristics**

The LB064V02-A1 requires two power inputs. One is employed to power the LCD electronics and to drive the TFT array and liquid crystal. The second input which powers the CCFL, is typically generated by an inverter. The inverter is an external unit to the LCD.

**Table 2. ELECTRICAL CHARACTERISTICS**

Parameter	Symbol	Values			Units	Notes
		Min.	Typ.	Max.		
<b>MODULE :</b>						
Power Supply Input Voltage	$V_{CC}$	3.0	3.3	3.6	Vdc	
Power Supply Input Current	$I_{CC}$	-	TBD	-	mA	1
Power Consumption	$P_C$	-	TBD	-	Watts	1
<b>LAMP :</b>						
Operating Voltage	$V_{BL}$	-	365	-	$V_{RMS}$	2
Operating Current	$I_{BL}$	-	5.0	-	mA	
Established Starting Voltage	$V_S$					3
at 25 °C		-	-	550	$V_{RMS}$	
at 0 °C		-	-	650	$V_{RMS}$	
Operating Frequency	$f_{BL}$	45	60	80	KHz	4
Discharge Stabilization Time	$T_s$			3	Minutes	5
Power Consumption	$P_{BL}$	-	1.825	-	Watts	6
Life Time		20,000	-	-	Hrs	7

Note : **The design of the inverter must have specification for the lamp in LCD Assembly.**

The performance of the Lamp in LCM, for example life time or brightness, is extremely influenced by the characteristics of the DC-AC inverter. So all the parameters of an inverter should be carefully designed so as not to produce too much leakage current from high-voltage output of the inverter.

When you design or order the inverter, please make sure unwanted lighting caused by the mismatch of the lamp and the inverter(no lighting, flicker, etc) never occurs. When you confirm it, the LCD Assembly should be operated in the same condition as installed in you instrument.

1. The specified current and power consumption are under the  $V_{CC}=3.3V$ ,  $25^{\circ}C$ ,  $f_v=60Hz$  condition whereas mosaic pattern is displayed and  $f_v$  is the frame frequency.
2. The variance of the voltage is  $\pm 10\%$ .
3. The voltage above  $V_S$  should be applied to the lamps for more than 1 second for start-up. Otherwise, the lamps may not be turned on. The used lamp current is the lamp typical current.

## Product Specification

4. The output of the inverter must have symmetrical(negative and positive) voltage waveform and symmetrical current waveform.(Unsymmetrical ratio is less than 10%) Please do not use the inverter which has unsymmetrical voltage and unsymmetrical current and spike wave.  
Lamp frequency may produce interface with horizontal synchronous frequency and as a result this may cause beat on the display. Therefore lamp frequency shall be as away possible from the horizontal synchronous frequency and from its harmonics in order to prevent interference.
5. Let's define the brightness of the lamp after being lighted for 5 minutes as 100%.  
 $T_s$  is the time required for the brightness of the center of the lamp to be not less than 95%.
6. The lamp power consumption shown above does not include loss of external inverter.  
The used lamp current is the lamp typical current.
7. The life is determined as the time at which brightness of the lamp is 50% compared to that of initial value at the typical lamp current on condition of continuous operating at  $25 \pm 2^\circ\text{C}$ .
8. Do not attach a conducting tape to lamp connecting wire.  
If the lamp wire attach to a conducting tape, TFT-LCD Module has a low luminance and the inverter has abnormal action. Because leakage current is occurred between lamp wire and conducting tape.

Product Specification

3-2. Interface Connections

This LCD employs two interface connections, a 20 pin connector is used for the module electronics and the other connector is used for the integral backlight system.

The electronics interface connector is a model GT101-30S-HR11 manufactured by LG Cable.

The pin configuration for the connector is shown in the table below.

**Table 3. MODULE CONNECTOR PIN CONFIGURATION**

Pin	Symbol	Description	Notes
1	GND	Ground	1. Connector 1.1 LCD : GT101-30S-HR11 (LG Cable) 1.2 Mating : FI-X30M ( JAE) or equivalent  2.3 Connector pin arrangement   [ LCD Module Rear View ]
2	VCC	Power (3.3V)	
3	VCC	Power (3.3V)	
4	GND	Ground	
5	DCLK	Data Input Clock	
6	DE	Data Enable Signal	
7	VSYNC	Vertical Sync Signal	
8	HSYNC	Horizontal Sync Signal	
9	GND	Ground	
10	R0	Red Data 0[LSB]	
11	R1	Red Data 1	
12	R2	Red Data 2	
13	R3	Red Data 3	
14	R4	Red Data 4	
15	R5	Red Data 5[MSB]	
16	GND	Ground	
17	G0	Green Data 0[LSB]	
18	G1	Green Data 1	
19	G2	Green Data 2	
20	G3	Green Data 3	
21	G4	Green Data 4	
22	G5	Green Data 5[MSB]	
23	GND	Ground	
24	B0	Blue Data 0[LSB]	
25	B1	Blue Data 1	
26	B2	Blue Data 2	
27	B3	Blue Data 3	
28	B4	Blue Data 4	
29	B5	Blue Data 5[MSB]	
30	GND	Ground	

The backlight interface connector is a model BHSR-02VS-1, manufactured by JST. The mating connector part number is SM02B-BHSS-1 by JST or equivalent.

The pin configuration for the connector is shown in the table below.

**Table 4. BACKLIGHT CONNECTOR PIN CONFIGURATION**

Pin	Symbol	Description	Notes
1	HV	Power supply for lamp(High voltage side)	www.DataSheet4U.com
2	LV	Power supply for lamp(Low voltage side)	1

Notes : 1. The high voltage side terminal is colored pink. The low voltage side terminal is black.



Product Specification

3-3. Signal Timing Specifications

This is the signal timing required at the input of the User connector. All of the interface signal timing should be satisfied with the following specifications for it's proper operation.

ITEM		SYMBOL	MIN	TYP.	MAX.	UNIT	NOTES
Dclk	Period	$t_{CLK}$	35	39.7	46	ns	
	Frequency	fclk	22	25	28	MHz	
Hsync	Period	$t_{HP}$	696	800	880	$t_{CLK}$	
	Width	$t_{WH}$	24	96	144		
Vsync	Period	$t_{VP}$	486	525	-	$t_{HP}$	
	Frequency	$f_V$	55	60	65	Hz	
	Width	$t_{WV}$	2	2	-	$t_{HP}$	
DE (Data Enable)	Horizontal Valid	$t_{HV}$	640	640	640	$t_{CLK}$	
	Horizontal Back Porch	$t_{HBP}$	16	40	-		
	Horizontal Front Porch	$t_{HFP}$	16	24	-		
	Horizontal Blank	-	56	160	$t_{HP} - t_{HV}$		$t_{WH} + t_{HBP} + t_{HFP}$
	Vertical Valid	$t_{VV}$	480	480	480	$t_{HP}$	
	Vertical Back Porch	$t_{VBP}$	2	33	-		
	Vertical Front Porch	$t_{VFP}$	2	10	-		
	Vertical Blank	-	6	45	$t_{VP} - t_{VV}$		$t_{WV} + t_{VBP} + t_{VFP}$

1. Hsync Period and Hsync Width-Active should be even number times of  $t_{CLK}$ .  
If the value is odd number times of  $t_{CLK}$ , display control signal can be asynchronous

Product Specification

3-4. Signal Timing Waveforms

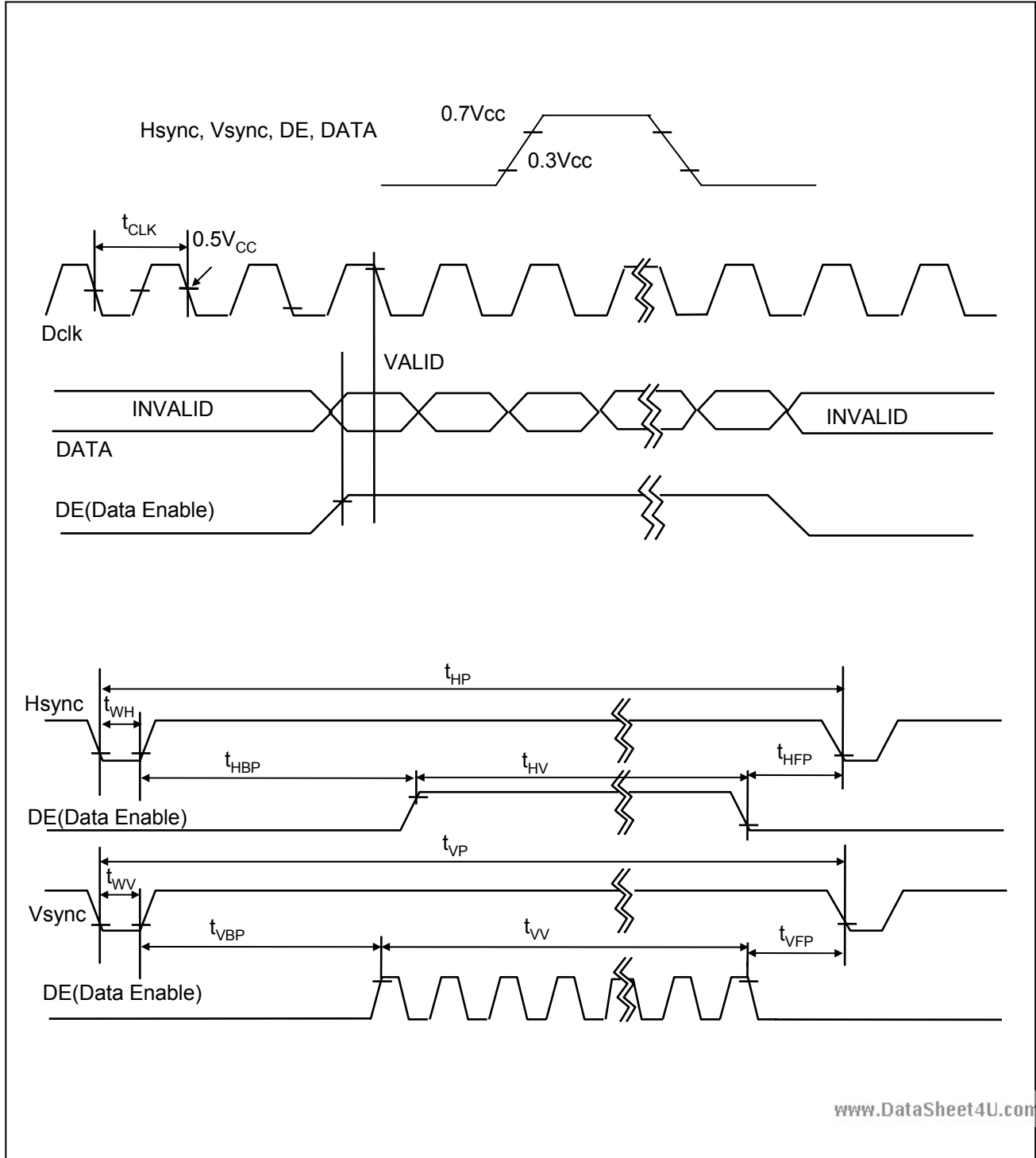

Product Specification

3-5. Color Input Data Reference

The brightness of each primary color(red,green and blue) is based on the 6-bit gray scale data input for the color ; the higher the binary input, the brighter the color. The table below provides a reference for color versus data input.

Table 7. COLOR DATA REFERENCE

Color		Input Color Data																	
		Red						Green						Blue					
		MSB		LSB				MSB		LSB				MSB		LSB			
	R5	R4	R3	R2	R1	R0	G5	G4	G3	G2	G1	G0	B5	B4	B3	B2	B1	B0	
Basic Colors	Black	0	0	0	0	0	0	0	0	0	0	0	0	0	0	0	0	0	0
	Red(63)	1	1	1	1	1	1	0	0	0	0	0	0	0	0	0	0	0	0
	Green(63)	0	0	0	0	0	0	1	1	1	1	1	1	0	0	0	0	0	0
	Blue(63)	0	0	0	0	0	0	0	0	0	0	0	0	1	1	1	1	1	1
	Cyan	0	0	0	0	0	0	1	1	1	1	1	1	1	1	1	1	1	1
	Magenta	1	1	1	1	1	1	0	0	0	0	0	0	1	1	1	1	1	1
	Yellow	1	1	1	1	1	1	1	1	1	1	1	1	0	0	0	0	0	0
	White	1	1	1	1	1	1	1	1	1	1	1	1	1	1	1	1	1	1
Red	Red(00) Dark	0	0	0	0	0	0	0	0	0	0	0	0	0	0	0	0	0	0
	Red(01)	0	0	0	0	0	1	0	0	0	0	0	0	0	0	0	0	0	0
	Red(02)	0	0	0	0	1	0	0	0	0	0	0	0	0	0	0	0	0	0
	:	:	:	:	:	:	:	:	:	:	:	:	:	:	:	:	:	:	:
	Red(61)	1	1	1	1	0	1	0	0	0	0	0	0	0	0	0	0	0	0
	Red(62)	1	1	1	1	1	0	0	0	0	0	0	0	0	0	0	0	0	0
	Red(63) Bright	1	1	1	1	1	1	0	0	0	0	0	0	0	0	0	0	0	0
Green	Green(00)Dark	0	0	0	0	0	0	0	0	0	0	0	0	0	0	0	0	0	0
	Green(01)	0	0	0	0	0	0	0	0	0	0	0	1	0	0	0	0	0	0
	Green(02)	0	0	0	0	0	0	0	0	0	0	1	0	0	0	0	0	0	0
	:	:	:	:	:	:	:	:	:	:	:	:	:	:	:	:	:	:	:
	Green(61)	0	0	0	0	0	0	1	1	1	1	0	1	0	0	0	0	0	0
	Green(62)	0	0	0	0	0	0	1	1	1	1	1	0	0	0	0	0	0	0
	Green(63)Bright	0	0	0	0	0	0	1	1	1	1	1	1	0	0	0	0	0	0
Blue	Blue(00) Dark	0	0	0	0	0	0	0	0	0	0	0	0	0	0	0	0	0	0
	Blue(01)	0	0	0	0	0	0	0	0	0	0	0	0	0	0	0	0	0	1
	Blue(02)	0	0	0	0	0	0	0	0	0	0	0	0	0	0	0	0	1	0
	:	:	:	:	:	:	:	:	:	:	:	:	:	:	:	:	:	:	:
	Blue(61)	0	0	0	0	0	0	0	0	0	0	0	0	1	1	1	1	0	1
	Blue(62)	0	0	0	0	0	0	0	0	0	0	0	0	1	1	1	1	1	0
	Blue(63) Bright	0	0	0	0	0	0	0	0	0	0	0	0	1	1	1	1	1	1

Product Specification

3-6. Power Sequence

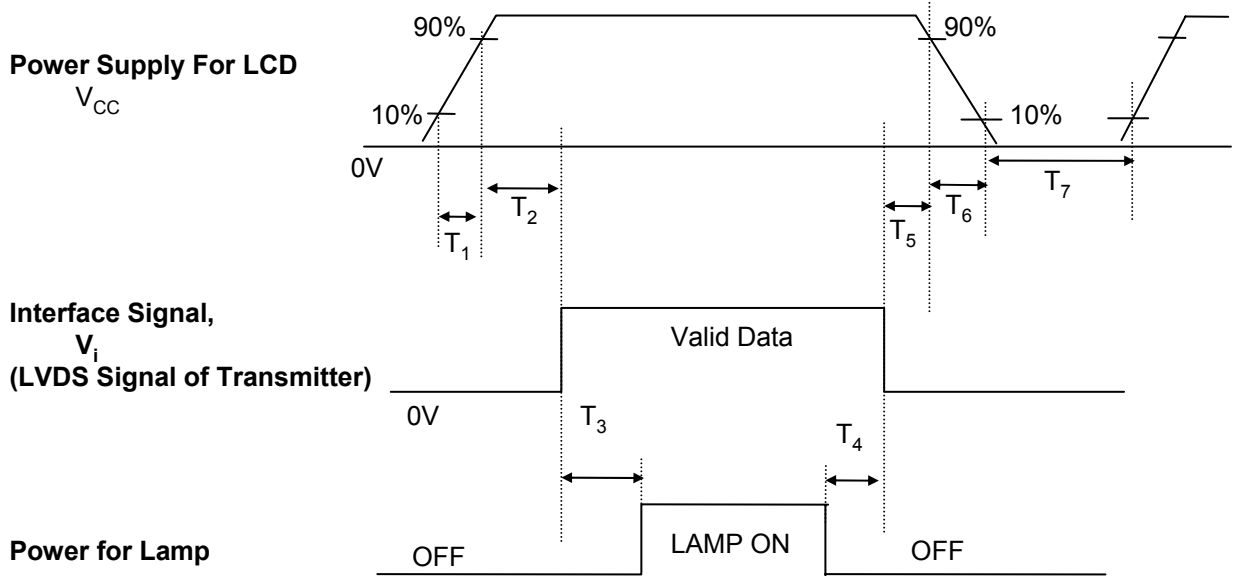

Parameter	Values			Units
	Min.	Typ.	Max.	
$T_1$	-	-	10	ms
$T_2$	0	-	50	ms
$T_3$	200	-	-	ms
$T_4$	200	-	-	ms
$T_5$	0	-	50	ms
$T_6$	-	-	10	ms
$T_7$	400	-	-	ms

- Notes :
1. Please avoid floating state of interface signal at invalid period.
  2. When the interface signal is invalid, be sure to pull down the power supply for LCD  $V_{CC}$  to 0V.
  3. Lamp power must be turn on after power supply for LCD and interface signal are valid.

Product Specification

4. Optical Specification

Optical characteristics are determined after the unit has been 'ON' and stable for approximately 30 minutes in a dark environment at 25 °C. The values specified are at an approximate distance 50cm from the LCD surface at a viewing angle of  $\Phi$  and  $\theta$  equal to 0 °.

FIG. 1 presents additional information concerning the measurement equipment and method.

FIG. 1 Optical Characteristic Measurement Equipment and Method

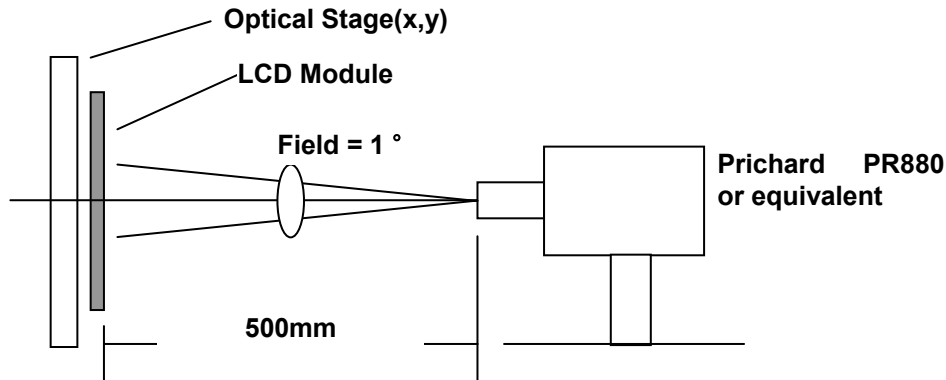

(Ta=25 °C, V<sub>CC</sub>=3.3V, f<sub>V</sub>=60Hz  
Dclk=25MHz, I<sub>BL</sub>=5mA)

Table 8. OPTICAL CHARACTERISTICS

Parameter	Symbol	Values			Units	Notes
		Min.	Typ.	Max.		
Contrast Ratio	CR	200	300	-		1
Surface Luminance, white	L <sub>WH</sub>	210	250	-	cd/m <sup>2</sup>	2
Luminance Variation	$\delta_{\text{WHITE}}$	-	1.4	1.6		3
Response Time	Tr				ms	4
Rise Time	Tr <sub>R</sub>	-	15	30		
Decay Time	Tr <sub>D</sub>	-	30	50		
CIE Color Coordinates						
Red	Rx	-	TBD	-		
Green	Ry	-	TBD	-		
Blue	Gx	-	TBD	-		
White	Gy	-	TBD	-		
	Bx	-	TBD	-		
	By	-	TBD	-		
	Wx	-	TBD	-		
	Wy	-	TBD	-		
Viewing Angle						
x axis, right( $\phi=0^\circ$ )	$\theta_r$	40	45	-	degree	5
x axis, left ( $\phi=180^\circ$ )	$\theta_l$	40	45	-		
y axis, up ( $\phi=90^\circ$ )	$\theta_u$	10	15	-		
y axis, down ( $\phi=270^\circ$ )	$\theta_d$	30	35	-		
Gray Sclae	-	-	-	-		6

www.DataSheet4U.com

Product Specification

Notes : 1. Contrast Ratio(CR) is defined mathematically as :

$$\text{Contrast Ratio} = \frac{\text{Surface Luminance with all white pixels}}{\text{Surface Luminance with all black pixels}}$$

2. Surface luminance is the center point across the LCD surface 50cm from the surface with all pixels displaying white. For more information see FIG 2.  
When  $I_{BL}=5\text{mA}$ ,  $L_{WH}=210\text{cd/m}^2(\text{Min.})$   $250\text{cd/m}^2(\text{Typ.})$

3. The variation in surface luminance,  $\delta$  WHITE is determined by measuring  $L_{ON}$  at each test position 1 through 5, and then dividing the maximum  $L_{ON}$  of 5 points luminance by minimum  $L_{ON}$  of 5 points luminance. For more information see FIG 2.

$$\delta \text{ WHITE} = \text{Maximum}(L_{ON1}, L_{ON2}, \dots, L_{ON5}) \div \text{Minimum}(L_{ON1}, L_{ON2}, \dots, L_{ON5})$$

4. Response time is the time required for the display to transition from to black(Rise Time,  $Tr_R$ ) and from black to white(Decay Time,  $Tr_D$ ). For additional information see FIG 3.

5. Viewing angle is the angle at which the contrast ratio is greater than 5. The angles are determined for the horizontal or x axis and the vertical or y axis with respect to the z axis which is normal to the LCD surface. For more information see FIG 4.

6. Gray scale specification

Gray Level	Luminance(%) (Typ.)
L0	TBD
L7	TBD
L15	TBD
L23	TBD
L31	TBD
L39	TBD
L47	TBD
L55	TBD
L63	TBD

Product Specification

FIG. 2 Luminance

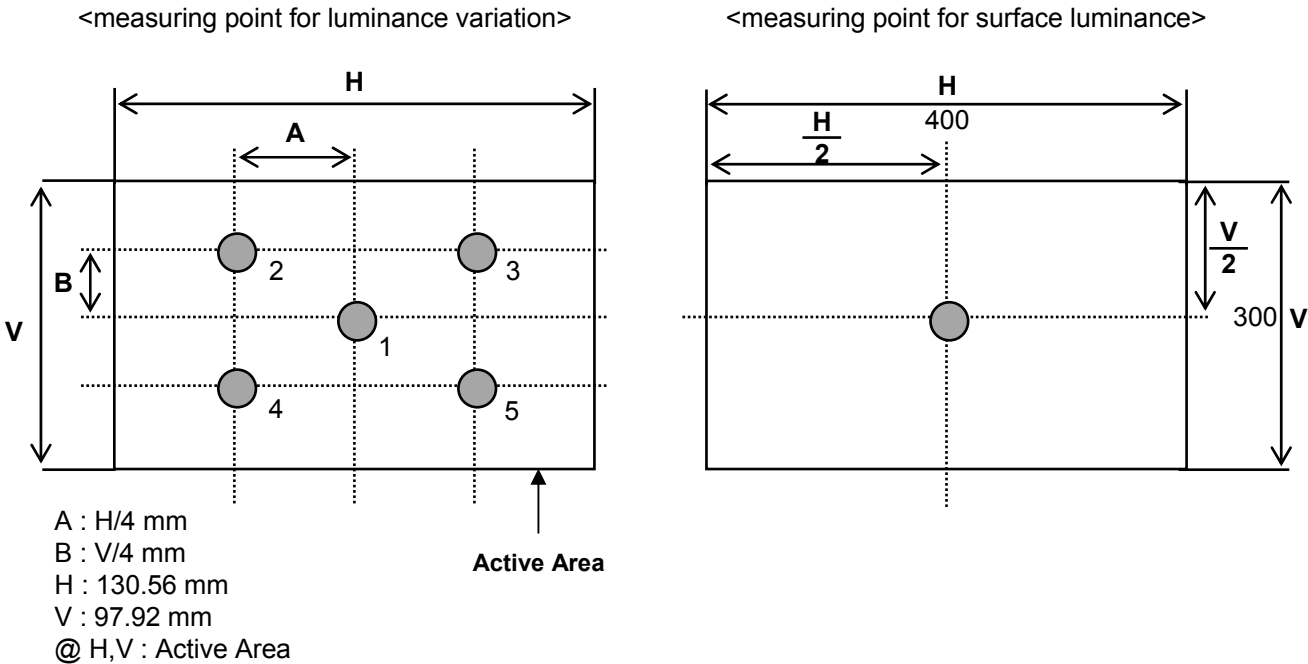
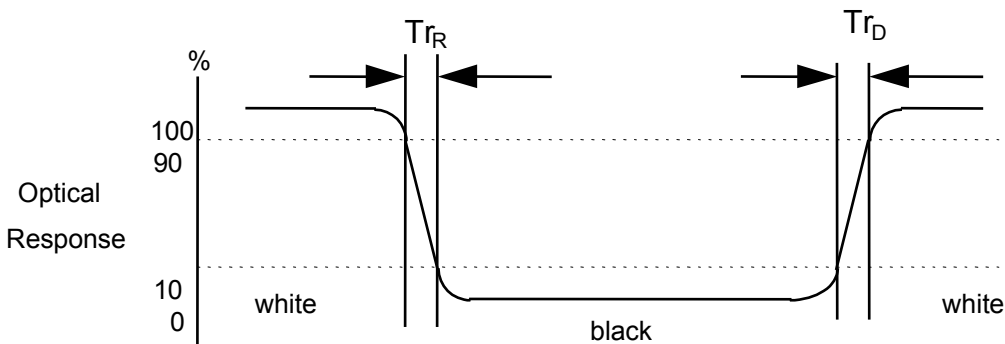

FIG. 3 Response Time

The response time is defined as the following figure and shall be measured by switching the input signal for "black" and "white".



Product Specification

FIG. 4 Viewing angle

<dimension of viewing angle range>

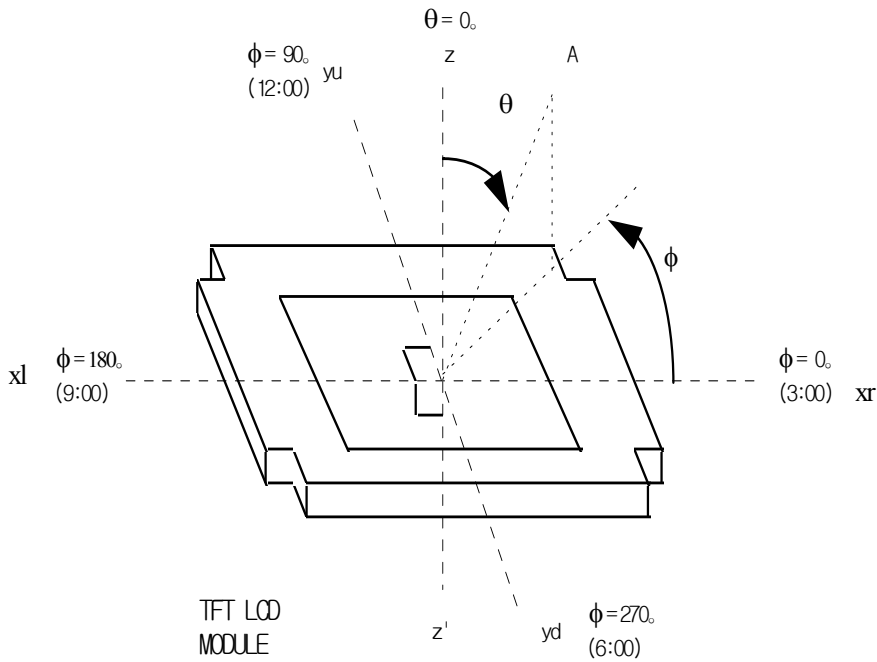



Product Specification

**5. Mechanical Characteristics**

The contents provide general mechanical characteristics for the model LP104S5-B2AP. In addition the figures in the next page are detailed mechanical drawing of the LCD.

Outside dimensions	Horizontal	145.5 ± 0.5mm
	Vertical	111.5 ± 0.5mm
	Depth	6.0 ± 0.3mm
Bezel area	Horizontal	133.8 ± 0.5mm
	Vertical	101.1 ± 0.5mm
Active display area	Horizontal	130.56mm
	Vertical	97.92mm
Weight(approximate)	160g(Typ.), 170g(Max.)	
Surface Treatment	Hard coating(3H) Anti-glare treatment of the front polarizer Haze(13%)	

Product Specification

<FRONT VIEW>

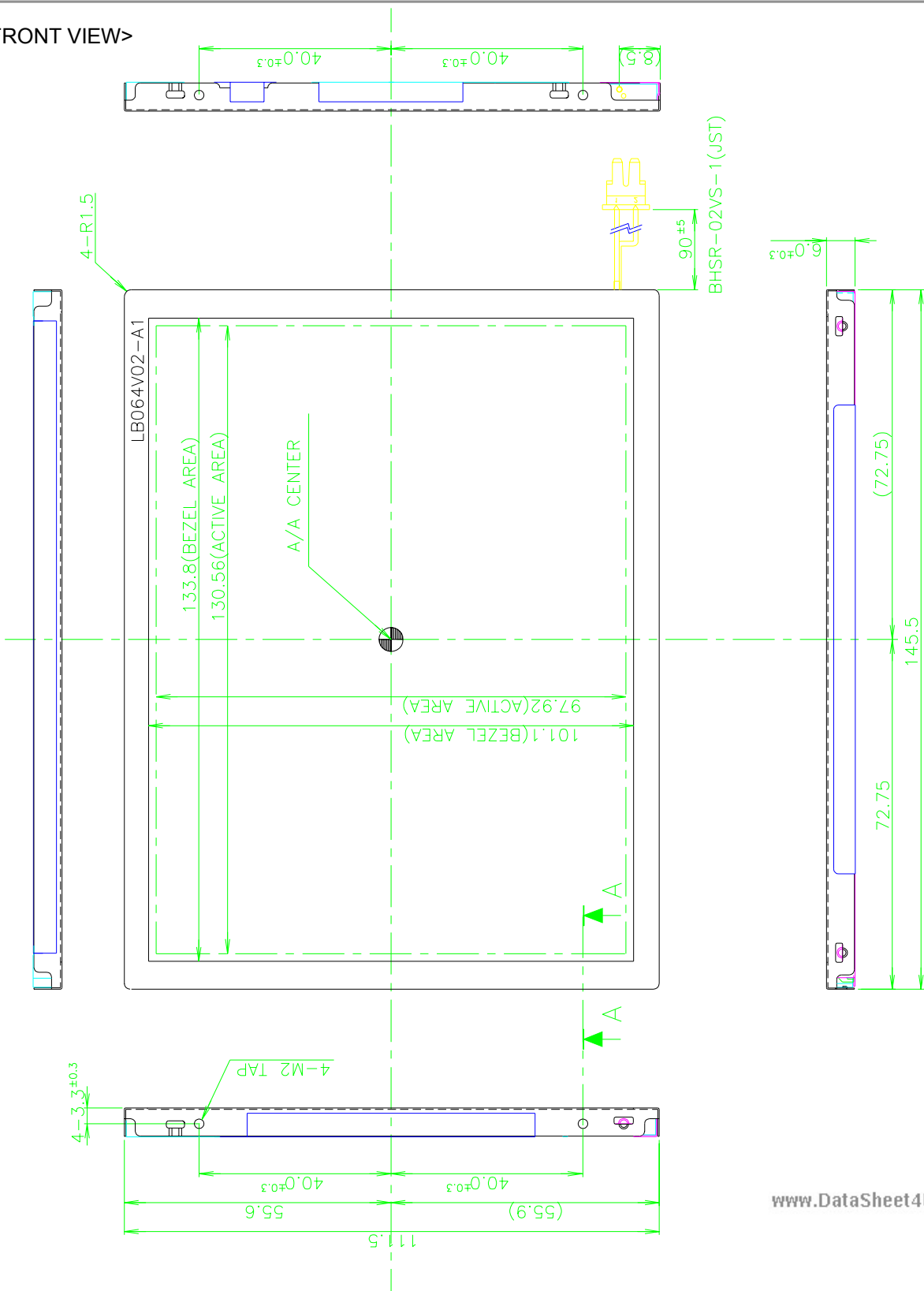

www.DataSheet4U.com

Product Specification

<REAR VIEW>

