

Product Specification

SPECIFICATION FOR APPROVAL

- () Preliminary Specification
 (●) Final Specification

Title	6.5" W (400 X RGB X 240) TFT – LCD
-------	-------------------------------------

BUYER	
MODEL	

SUPPLIER	LG.Philips LCD Co., Ltd.
MODEL	LB065WQ3
SUFFIX	TD02

SIGNATURE	DATE
/	_____
/	_____
/	_____

Please return 1 copy for your confirmation with your signature and comments.

SIGNATURE	DATE
C. S. KYEONG/ G.Manager	_____
REVIEWED BY	_____
S. D. JUNG/ Manager	_____
PREPARED BY	_____
K. J. LEE/ Engineer	_____

**Products Engineering Dept.
LG. Philips LCD Co., Ltd**

Product Specification

Contents

No	Item	Page
	Cover	1
	Contents	2
	Record of Revision	3
1	Summary	
2	Feature	
3	General Specification	5
4	Absolute Maximum Rating	
5	Electrical Specification	6
5-1	Electrical Characteristics	
5-2	Interface Connection	7
5-3	Signal Timing Specification	10
5-4	Signal Timing Waveform	11
5-5	Color Input Data Reference	12
5-6	Power Sequence	13
5-7	Touch Panel Specification	14
6	Optical Specification	15
7	Mechanical Characteristics	19
8	Reliability Test	22
9	International Standard	23
9-1	Safety	
9-2	EMC	
10	Packing	24
10-1	Designation of LOT Mark	
10-2	Packing Form	
11	Precaution	25

Product Specification

1. Summary

This module utilizes amorphous silicon thin film transistors and a 16:9 aspect ratio. A 6.5" active matrix liquid crystal display allows full color to be displayed. The applications are Portable DVD, Amusement and others AV system. This model is composed of a TFT-LCD module(TFT-LCD panel, driver ICs, FPC and control circuit board), a Back-Light unit and a touch screen panel.

2. Feature

- Utilizes a panel with a 16:9 aspect ratio, which makes the module suitable for use in wide-screen systems.
- The 6.5" screen produces a high resolution image that is composed of 96,000 pixel elements in a stripe arrangement.
- Wide viewing angle technology is employed.
[The most suitable viewing direction is in the 6 o'clock direction.]
- By adopting an active matrix drive, a picture with high contrast is realized.
- A thin, light and compact module is accomplished through the use of COG mounting technology.
- By adopting a high aperture panel, high transmittance color filter and high transmission polarizing plates, transmittance ratio is realized.
- Gray scale or the brightness of the sub-pixel color is determined with a 6-bit gray scale signal.
- 4 wire resistive analog touch screen panel is included.

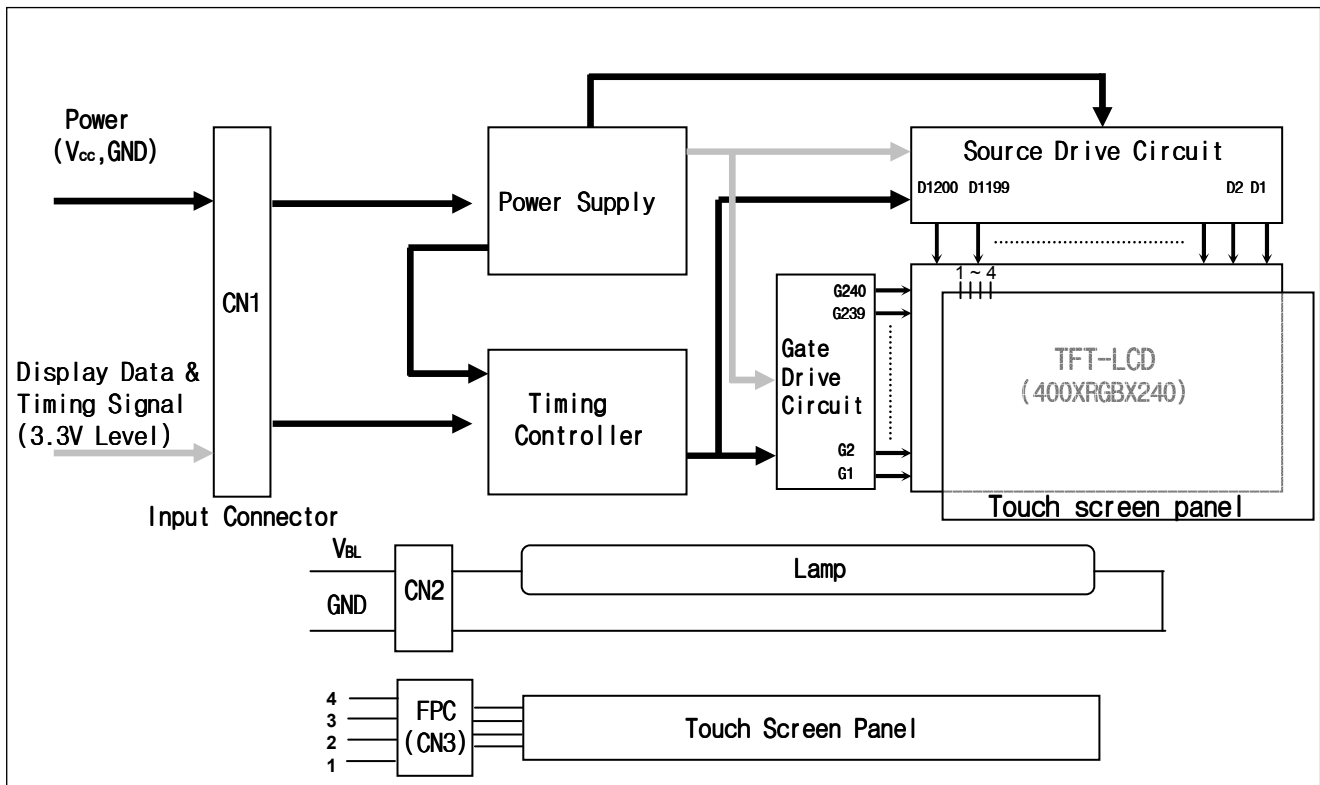

Product Specification

3. General Specification

Characteristic Item	Specification
Signal Interface	Digital Interface (CMOS TTL)
Display Mode	Normally White, Transmitting Type
Screen Size (Diagonal)	6.5" (16.5cm)
Outline Dimension	155.3mm (H) X 91mm (V) X 11.6mm (D)
Active Area	143.4mm (H) X 79.32mm (V)
Number Of Dots	400(H) X 3(R,G,B) X 240(V)
Color Depth	6 Bit, 262,144 Colors
Pixel Pitch	0.3585mm(H) × 0.3305mm(V)
Color Filter Array	RGB Vertical Stripes
Power Consumption	4.2 Watt(Typ)
Weight	210(Typ)
Backlight	CCFL (L Type)

4. Absolute Maximum Rating

The following are maximum values which, if exceeded, may cause faulty operation or damage to the unit.

Table 1. Absolute Maximum Rating

Parameter	Symbol	Value		Unit	Note
		Min.	Max.		
Power Input Voltage	VCC	-0.3	Vcc + 0.3	Vdc	at 25 ± 5°C
Operating Temperature	TOP	-0	50	°C	*4-1,2,3
	TOP*	-30	85	°C	
Storage Temperature	TST	-20	60	°C	*4-1,2

[Note 4-1] This rating applies to all parts of the module and should not be exceeded.

[Note 4-2] Maximum wet-bulb temperature is 38°C. Condensation of dew must be avoided as electrical current leaks will occur, causing a degradation of performance specification.

[Note 4-3] TOP* is the operating temperature of LCM without touch panel. The operating temperature only guarantees operation of the circuit and doesn't guarantee all the contents of Electro-optical specification.

Product Specification

5. Electrical Specification

5-1. Electrical Characteristics

The LB065WQ3-TD02 requires three power inputs. One is employed to power the LCD electronics and to drive the TFT array and liquid crystal. The second input which powers the CCFL, is typically generated by an inverter. The inverter is an external unit to the LCD. The third is for touch screen panel.

Table 2. Electrical Characteristics

Parameter	Symbol	Value			Unit	Note
		Min.	Typ.	Max.		
Module :						
Power Supply Input Voltage	VCC	3.0	3.3	3.6	Vdc	
Power Supply Input Current	I _{CC}	105	133	165	mA	*5-1
Power Consumption	Pc	-	0.44	0.60	Watt	*5-1
Lamp :						
Operating Voltage	V _{BL}	520(6.5mA)	550(6mA)	670(3mA)	V _{RMS}	±10[%]
Operating Current	I _{BL}	3.0	6.0	6.5	mA _{RMS}	
Operating Frequency	f _{BL}	40		60	kHz	*5-2
		40		80		
Kick-Off Voltage (*5-4)	Vs	-	-	1440	V _{RMS}	T _a =25°C
		-	-	1720		
Discharge Stabilization Time	Ts	-	-	3	Min	*5-5
Power Consumption	P _{BL}	-	3.30	3.63	Watt	at I _{BL} =TYP
Life Time		20,000	-	-	Hrs	*5-6
Touch Screen Panel						
Operating Voltage	V _{TS}	-	5	7	Vdc	

Note) **The design of the inverter must have specifications for the lamp in LCD Assembly.**

The performance of the Lamp in LCM, for example, life time or brightness, is extremely influenced by the characteristics of the DC-AC inverter. So all the parameters of an inverter should be carefully designed so as not to produce too much leakage current from high-voltage output of the inverter. When you design or order the inverter, please make sure unwanted lighting not caused by the mismatch of the lamp and the inverter(no lighting, flicker, etc) never occur. When you confirm it, the LCD Assembly should be operated in the same condition as installed in your instrument.

[Note 5-1] VCC=3.3V, 25°C, f_v (frame frequency) = 60Hz condition, whereas mosaic pattern(Typ), full black pattern(Max) is displayed.

[Note 5-2] This frequency range means the range to keep within ±10% change of electrical and optical characteristics.

[Note 5-3] This frequency range means not affecting to lamp life and reliability characteristics.

(The lamp frequency should be selected as different as possible from display horizontal synchronous signal (Including harmonic frequency of this scanning frequency) to avoid "Beat" interference which may be observed on the screen as horizontal stripes like moving wave.

Product Specification

This phenomenon is caused by interference between lamp (CCFL) lighting frequency and LCD horizontal synchronous signal.)

[Note 5-4] The “MAX” of “Kick-Off Voltage” means the minimum voltage for inverter to turn on the CCFL normally in the LCD module. However this isn't the values that we can assure stability of starting lamp on condition that the module is installed in your set.

It should be careful that “Kick-Off Voltage” is changed by an increase of stray capacitance in your set, inverter method, value of ballast capacitor in your inverter and so on.

Especially, the value of “Kick-Off Voltage” is higher in low temperature condition than innormal temperature condition, because impedance of CCFL is increased.

The voltage above V_S should be applied to the lamps for more than 1 second for start-up.

Otherwise, the lamps may not be turned on. The used lamp current is the lamp typical current.

[Note 5-5] The time needed to achieve not less than 95% brightness of the center part of lamp.

The brightness of the lamp after being lighted for 5 minutes is defined as 100%.

[Note 5-6] “Life time” is defined as the time that the lamp brightness decreases to 50% from original brightness at $I_{BL}=TYP$; continuous lighting, $T_a=25^{\circ}C$.

Requirements for a system inverter design, which is intended to have a better display performance, a better power efficiency and a more reliable lamp, are as follows. It shall help increase the lamp lifetime and reduce leakage current. Inverter should be designed to be subject to the conditions below

- A. The asymmetry rate of the inverter waveform should be less than 10%.
 - B. The distortion rate of the waveform should be within $\sqrt{2} \pm 10\%$.
- * Inverter output waveform had better be more similar to ideal sine wave.

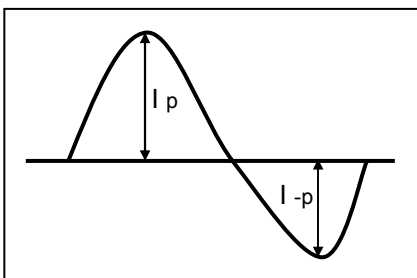

* Asymmetry rate:

$$(I_p - I_{-p}) / I_{rms} * 100\%$$
 •Distortion rate:

$$I_p \text{ (or } I_{-p}) / I_{rms}$$

- C. There should not be any spikes in the waveform.
- D. Lamp current should not exceed the “MAX” value under the “Operating Temperature”. (It is prohibited to exceed the “MAX” value even if it is operated in the guaranteed temperature).
 When lamp current exceed the maximum value for a long time, it may cause a smoking and Ignition.
 Therefore, it is recommended that the inverter have the current limited circuit that is used as a protection circuit and/or the lamp current-controlled inverter.

* Do not attaches a conducting tape to lamp connecting wire.
 If the lamp wire attach to a conducting tape, TFT-LCD Module has a low luminance and the inverter has abnormal action. Because leakage current is occurred between lamp wire and conducting tape.

5-2. Interface Connection

This LCD employs two interface connections, 40-pin connector is used for the module electronics interface and the other is used for the integral backlight system.

The interface connector is a model **FH12K-40S-0.5SH** manufactured by HIROSE.

Product Specification

Table 3. Module Connector Pin Configuration (CN1)

Pin	Symbol	Description	Notes
1	VDD	Power Input	+3.3VCC Power Supply Input, Note 5-8
2	VDD	Power Input	
3	VDD	Power Input	
4	VDD	Power Input	
5	GND	Ground	Connect to VSS, Note 5-7
6	GND	Ground	
7	N.C	No Connection	Do Not Connect
8	N.C	No Connection	
9	GND	Ground	Connect to VSS, Note 5-7
10	N.C	No Connection	
11	VS	Vertical Sync	Vertical Sync Signal
12	DE	Data Enable	Data Enable Signal
13	HS	Horizontal Sync	Horizontal Sync Signal
14	GND	Ground	
15	B5	Blue Data	Blue Data Most Significant Bit(MSB)
16	B4	Blue Data	
17	B3	Blue Data	
18	GND	Ground	
19	B2	Blue Data	Connect to VSS, Note 5-7
20	B1	Blue Data	
21	B0	Blue Data	Blue Data Least Significant Bit(LSB)
22	GND	Ground	Connect to VSS, Note 5-7
23	G5	Green Data	Green Data Most Significant Bit(MSB)
24	G4	Green Data	
25	G3	Green Data	
26	GND	Ground	
27	G2	Green Data	Connect to VSS, Note 5-7
28	G1	Green Data	
29	G0	Green Data	Green Data Least Significant Bit(LSB)
30	GND	Ground	Connect to VSS, Note 5-7
31	R5	Red Data	Red Data Most Significant Bit(MSB)
32	R4	Red Data	
33	R3	Red Data	
34	GND	Ground	
35	R2	Red Data	Connect to VSS, Note 5-7
36	R1	Red Data	
37	R0	Red Data	Red Data Least Significant Bit(LSB)
38	GND	Ground	Connect to VSS, Note 5-7
39	DCLK	Data Clock	Data Clock Signal
40	GND	Ground	Connect to VSS, Note 5-7

[Note 5-7] All VSS(Ground) pins should be connected together and the LCD's metal frame.

[Note 5-8] All VCC(Power input) pins should be connected together.

Product Specification

Table 4. Backlight Connector Pin Configuration(CN2)

Pin No.	Symbol	Function	Remark
1	HV	Power Supply For Lamp [High Voltage Side]	*5-9
2	NC	No Connection	
3	LV	Power Supply For Lamp [Low Voltage Side]	*5-10

The backlight interface connector is a model **BHR-03VS-1** manufactured by JST or a compatible model manufactured by AMP. The matching connector is **SM02(8.0)B-BHS-1-TB** manufactured or equivalent.

[Note 5-9] The wire color of high voltage side is pink.

[Note 5-10] The wire color of low voltage side is black. Connect the low voltage side of the DC/AC inverter used to drive the fluorescent tube to GND of the inverter circuit.

Table 5. Touch Panel Pin Configuration(CN3)

Pin No.	Symbol	Function	Note
1	Y1	Up Resistance Terminal	
2	X1	Right Resistance Terminal	
3	Y2	Bottom Resistance Terminal	
4	X2	Left Resistance Terminal	

Product Specification

5-3. Signal Timing Specification

Table 4. Timing Table

Item	Symbol	Min.	Typ.	Max.	Unit	Note		
DCLK	Frequency	f_{CLK}	7.7	8.3	10.8	MHz		
	Width_Low	t_{WCL}	4	-	-	ns		
	Width_High	t_{WCH}	4	-	-			
HS	Period	t_{HP}	512	528	544	t_{CLK}		
	Width_Active	t_{WH}	8	32	48			
	Rise/Fall Time	t_{Hr}, t_{Hf}	-	-	30	ns		
VS	Period	t_{VP}	250	263	330	t_{Hp}		
	Width_Active	T_{WV}	2	-	-			
	Rise/Fall Time	t_{Vr}, t_{Vf}	-	-	50	ns		
DE	Setup Time	t_{SI}	3	-	-	ns	For DCLK	
	Hold Time	t_{HI}	1	-	-			
	Rise/Fall Time	t_{Ir}, t_{If}	-	-	30	ns		
	Horizontal Display Period	t_{HDP}	400	400	400	clock		
	Vertical Display Period	t_{VDP}	240	240	240	line		
	Horizontal Back Porch	t_{HBP}	12	64	64	t_{CLK}		
	Horizontal Front Porch	t_{HFP}	8	32	32			
	Vertical Back Porch	t_{VBP}	6	-	-	t_{Hp}		
	Vertical Front Porch	t_{VFP}	2	-	-			
Data	Setup Time	t_{SD}	2	-	-	ns		For DCLK
	Hold Time	t_{HD}	2	-	-			
	Rise/Fall Time	t_{Dr}, t_{Df}	-	-	25	ns		

Product Specification

5-4. Signal Timing Waveform [$V_{dd} = 3.3V$]

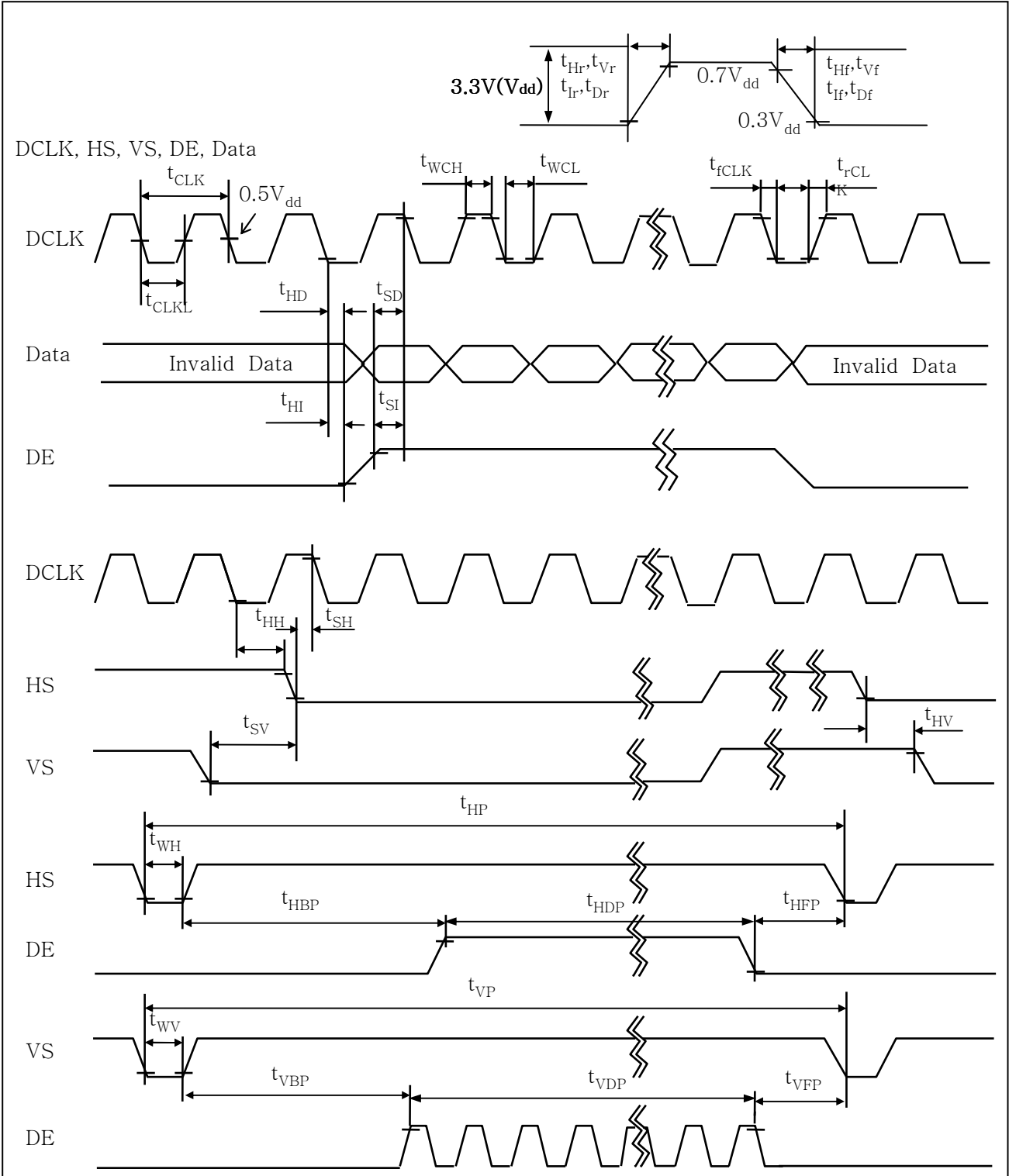

Product Specification

5-5. Color Input Data Reference

The brightness of each primary color (red, green and blue) is based on the 6-bit gray scale data input for the color; the higher the binary input, the brighter the color. The table below provides a reference for color versus data input.

Table 6. Color Data Reference

Color		Input Color Data																	
		RED						GREEN						BLUE					
		MSB				LSB		MSB				LSB		MSB		LSB			
		R5	R4	R3	R2	R1	R0	G5	G4	G3	G2	G1	G0	B5	B4	B3	B2	B1	B0
Basic Color	BLACK	0	0	0	0	0	0	0	0	0	0	0	0	0	0	0	0	0	0
	RED	1	1	1	1	1	1	0	0	0	0	0	0	0	0	0	0	0	0
	GREEN	0	0	0	0	0	0	1	1	1	1	1	1	0	0	0	0	0	0
	BLUE	0	0	0	0	0	0	0	0	0	0	0	0	1	1	1	1	1	1
	CYAN	0	0	0	0	0	0	1	1	1	1	1	1	1	1	1	1	1	1
	MAGENTA	1	1	1	1	1	1	0	0	0	0	0	0	1	1	1	1	1	1
	YELLOW	1	1	1	1	1	1	1	1	1	1	1	1	0	0	0	0	0	0
	WHITE	1	1	1	1	1	1	1	1	1	1	1	1	1	1	1	1	1	1
RED	RED (00)	0	0	0	0	0	0	0	0	0	0	0	0	0	0	0	0	0	0
	RED (01)	0	0	0	0	0	1	0	0	0	0	0	0	0	0	0	0	0	0
					
	RED (62)	1	1	1	1	1	0	0	0	0	0	0	0	0	0	0	0	0	0
	RED (63)	1	1	1	1	1	1	0	0	0	0	0	0	0	0	0	0	0	0
GREEN	GREEN (00)	0	0	0	0	0	0	0	0	0	0	0	0	0	0	0	0	0	0
	GREEN (01)	0	0	0	0	0	0	0	0	0	0	0	1	0	0	0	0	0	0
					
	GREEN (62)	0	0	0	0	0	0	1	1	1	1	1	0	0	0	0	0	0	0
	GREEN (63)	0	0	0	0	0	0	1	1	1	1	1	1	0	0	0	0	0	0
BLUE	BLUE (00)	0	0	0	0	0	0	0	0	0	0	0	0	0	0	0	0	0	0
	BLUE (01)	0	0	0	0	0	0	0	0	0	0	0	0	0	0	0	0	0	1
					
	BLUE (62)	0	0	0	0	0	0	0	0	0	0	0	0	1	1	1	1	1	0
	BLUE (63)	0	0	0	0	0	0	0	0	0	0	0	0	1	1	1	1	1	1

5-6. Power Sequence

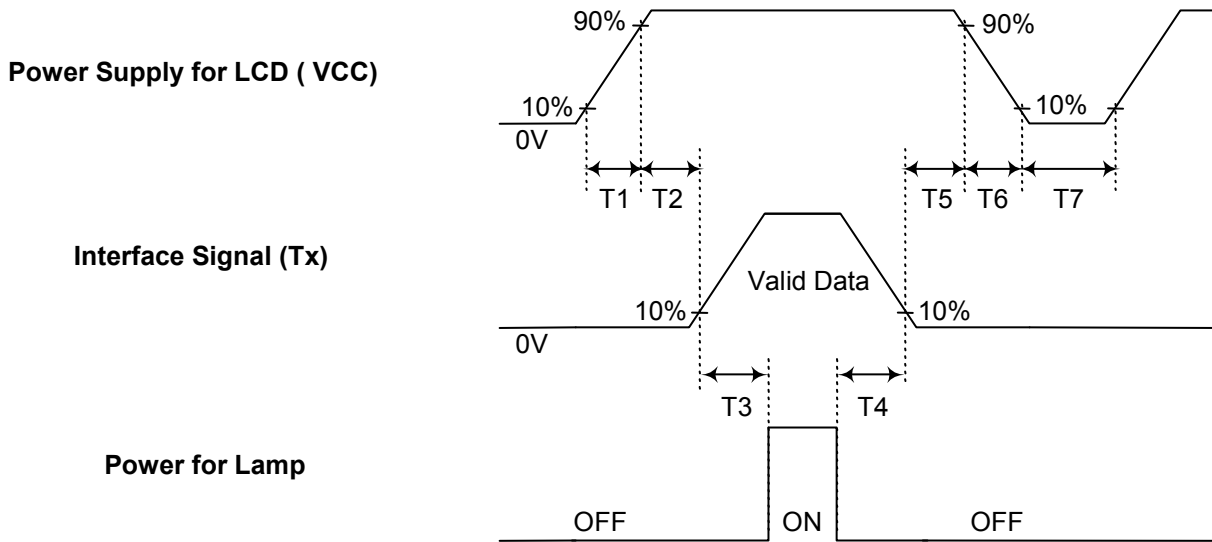

Table 7. Power Sequence Table

Parameter	Value			Unit
	Min.	Typ.	Max.	
T ₁	-	-	10	(ms)
T ₂	0	-	50	(ms)
T ₃	200	-	-	(ms)
T ₄	200	-	-	(ms)
T ₅	0	-	50	(ms)
T ₆	-	-	10	(ms)
T ₇	2,000	-	-	(ms)

[Note 5-11] Please avoid floating state of interface signal at invalid period.

[Note 5-12] When the interface signal is invalid, be sure to pull down the power supply for LCD VCC to 0V.

[Note 5-13] Lamp power must be turn on after power supply for LCD and interface signal are valid.

Product Specification

5-7. Touch Screen Panel Specification

5-7-1. Electrical Characteristics

Item	Min.	Typ.	Max.	Unit	Note
Linearity	-1.5	-	1.5	%	Each X/Y Direction
Terminal Resistance	350	-	1300	Ω	X(Film Side)
	120	-	550	Ω	Y(Glass Side)
Insulation Resistance	10	-	-	M Ω	DC 25V
Voltage	-	5	7	V	
Chattering	-	-	20	ms	At Connector Pin

5-7-2. Mechanical Characteristics

Item	Min.	Typ.	Max.	Unit	Note
ITO Glass	-	-	1.1	mm	
ITO Film	-	-	0.1	μ m	
Input Activation Force	-	-	80	g	*5-1
Notes Life Test	10 ⁵	-	-	word	*5-2
Input Life Test	10 ⁶	-	-	times	*5-3
Surface Hardness	3	-	-	H	JIS K5600

[Note 5-1] Stylus pen Input : R0.8mm polyacetal pen or silicon rubber.

[Note 5-2] Notes life test condition : load 250g, speed 60mm/s

[Note 5-3] Input life test condition : load 200g, frequency 5Hz

Product Specification

6. Optical Specification

Optical characteristics is determined after the unit has been 'ON' and stable for approximately 30 minutes in a dark environment at 25°C. The values specified are at an approximate distance 50cm from the LCD surface at a viewing angle of Φ and Θ equal to 0°.

FIG. 1 presents additional information concerning the measurement equipment and method.

FIG. 1 Optical Characteristic Measurement Equipment and Method

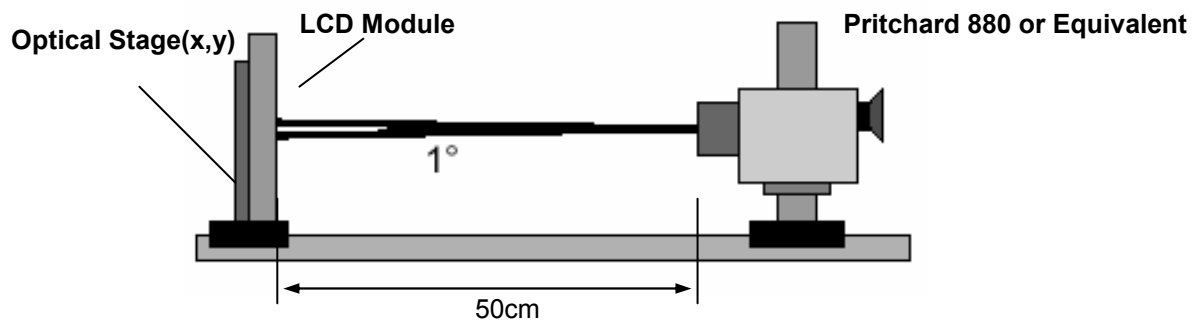

Table 8. Optical Characteristics

Ta=25°C, VCC=5.0V, fv=60Hz, Dclk= 8.3MHz, IL=6.0mA

Parameter	Symbol	Value			Unit	Notes
		Min	Typ	Max		
Contrast Ratio	CR	300	400	-	-	*6-1
Surface Luminance, White	L _{WH}	280	350	-	cd/m ²	*6-2
Luminance Variation	δ_{WHITE}	-	1.25	1.40	-	*6-3
Response Time						*6-4
Rising Time	Tr _R	-	10	20	ms	
Falling Time	Tr _D	-	30	45	ms	
Color Coordinate						
RED	RX	0.549	0.599	0.649		
RY		0.296	0.346	0.396		
GREEN	GX	0.288	0.338	0.388		
GY		0.488	0.538	0.588		
BLUE	BX	0.110	0.160	0.210		
BY		0.116	0.166	0.216		
WHITE	WX	0.270	0.320	0.370		
WY		0.291	0.341	0.391		
Viewing Angle (CR≥5)						*6-5
X Axis, Right($\Phi=0^\circ$)	Θ_r	60	65	-	degree	
X Axis, Left($\Phi=180^\circ$)	Θ_l	60	65	-	degree	
Y Axis, Up($\Phi=90^\circ$)	Θ_u	40	50	-	degree	
Y Axis, Down($\Phi=270^\circ$)	Θ_d	60	65	-	degree	

Product Specification

[Note 6-1] Contrast Ratio(CR) is defined as

$$\text{Contrast Ratio} = \frac{\text{Surface Luminance with All White Pixels}}{\text{Surface Luminance with All Black Pixels}}$$

[Note 6-2] Surface luminance is the center point across the LCD surface 50cm from the surface with all pixels displaying white(included the Touch Panel). For more information see FIG 1.

[Note 6-3] The variation in surface luminance , The panel total variation (δ_{WHITE}) is determined by measuring L_N at each test position 1 through 5, and then dividing the maximum L_N of 5 points luminance by minimum L_N of 5 points luminance. For more information see FIG 2.

$$\delta_{\text{WHITE}} = \text{Maximum}(L_1, L_2, \dots, L_5) / \text{Minimum}(L_1, L_2, \dots, L_5)$$

[Note 6-4] Response time is the time required for the display to transition from white to black (rising time, Tr_R) and from black to white(falling time, Tr_D). For additional information see FIG 3.

[Note 6-5] Viewing angle is the angle at which the contrast ratio is greater than 5. The angles are determined for the horizontal or x axis and the vertical or y axis with respect to the z axis which is normal to the LCD surface. For more information see FIG 4.

FIG. 2 Luminance

<Measuring point for surface luminance & measuring point for luminance variation>

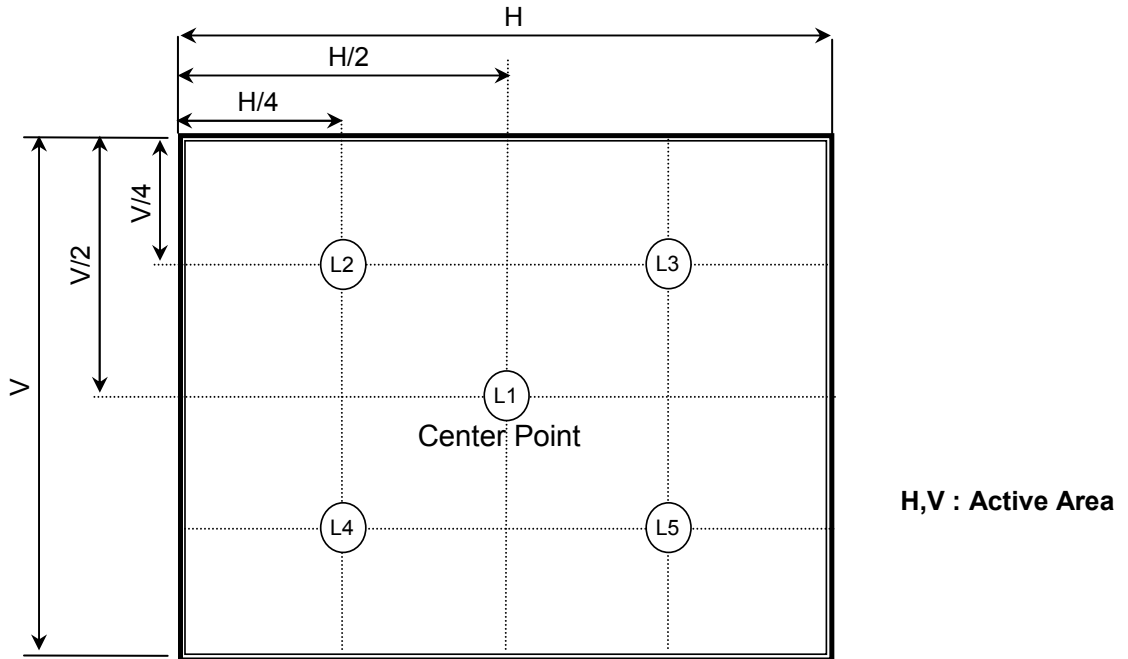
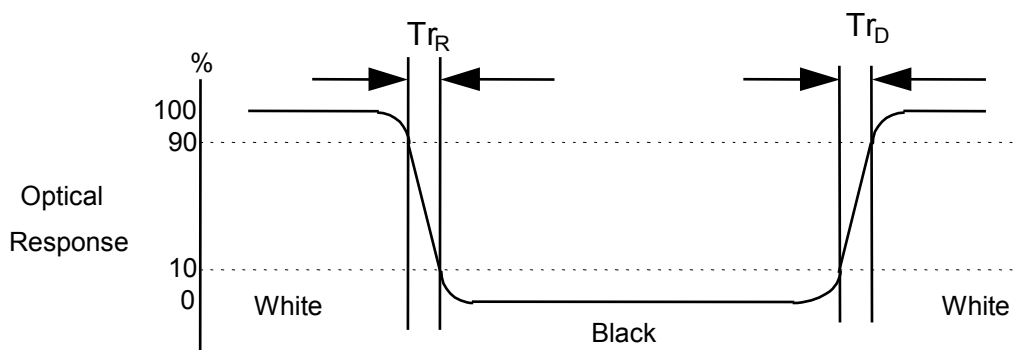

FIG. 3 Response Time

The response time is defined as the following figure and shall be measured by switching the input signal for "black" and "white".



Product Specification

FIG. 4 Viewing Angle

<Dimension of Viewing Angle Range>

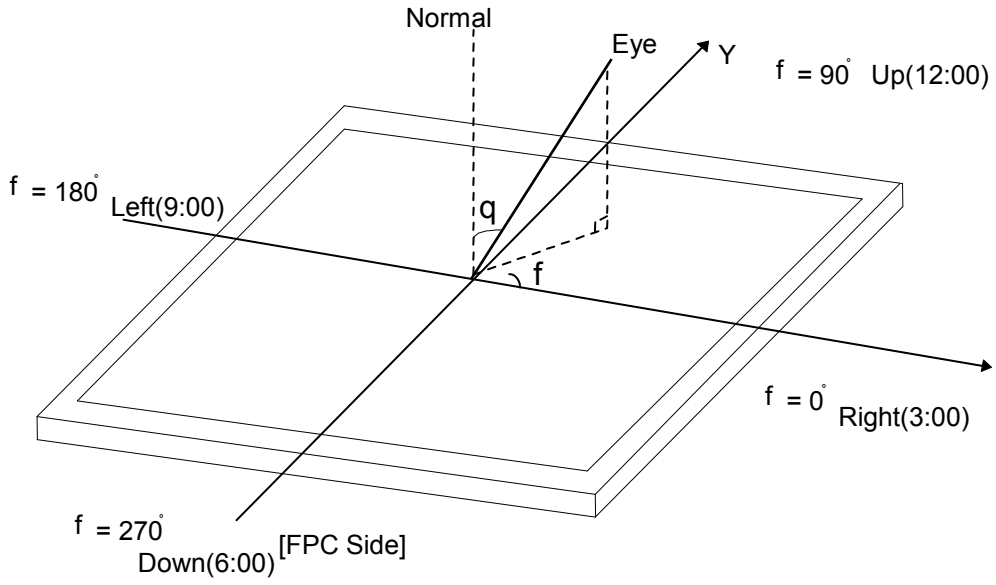

Product Specification

7. Mechanical Characteristics

The contents provide general mechanical characteristics for the model LB065WQ3-TD02. In addition the figures in the next two pages are detailed mechanical drawings of the LCD.

Outline Dimension	Horizontal	155.3(± 0.5)mm
	Vertical	91.0(± 0.5)mm
	Depth	11.6(± 0.5)mm
Bezel Area	Horizontal	146.6(± 0.3)mm
	Vertical	82.0(± 0.3)mm
Active Display Area	Horizontal	143.4 mm
	Vertical	79.32 mm
Weight	210(Typ)/220(Max)	

Product Specification

<Front View>

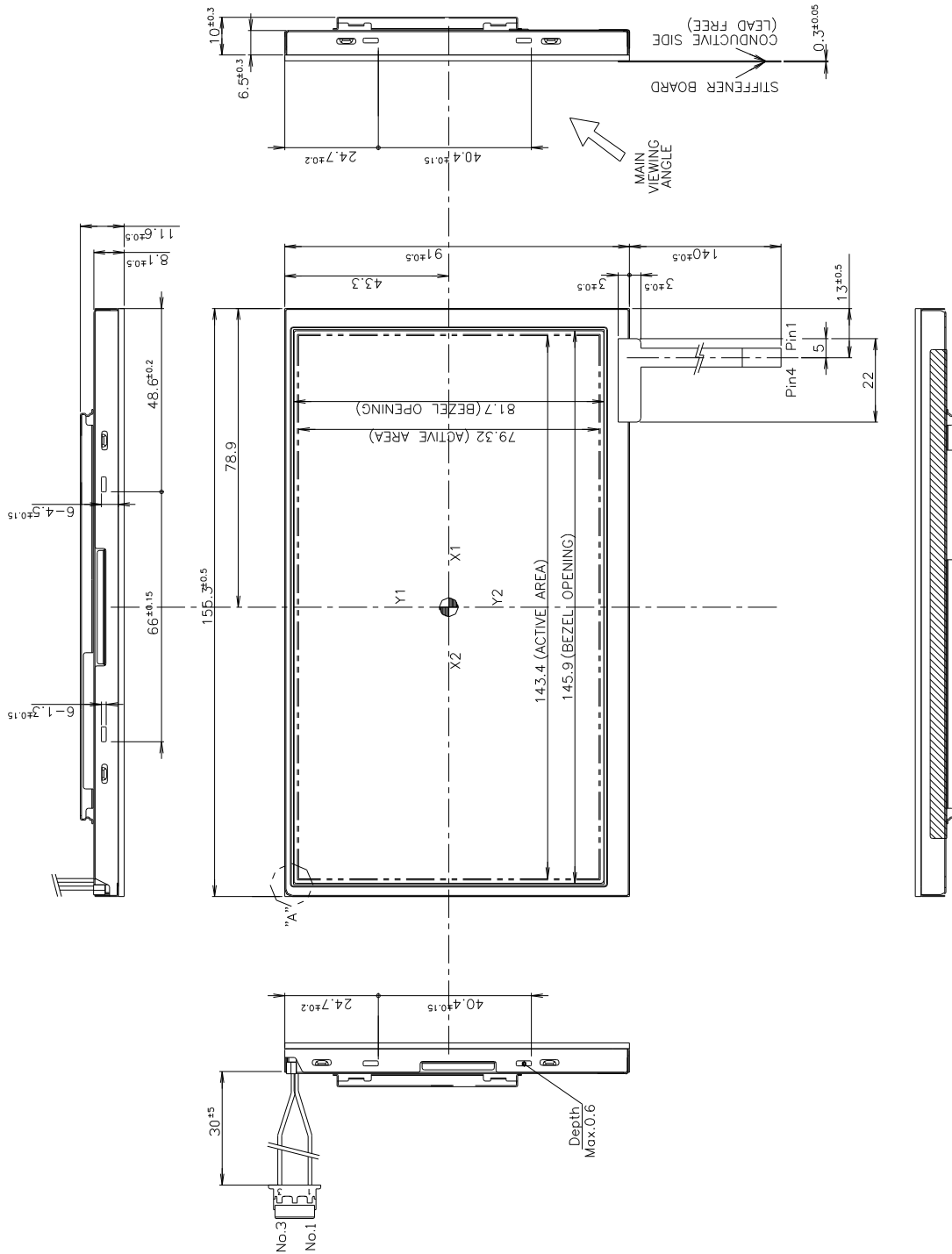

Product Specification

<Rear View>

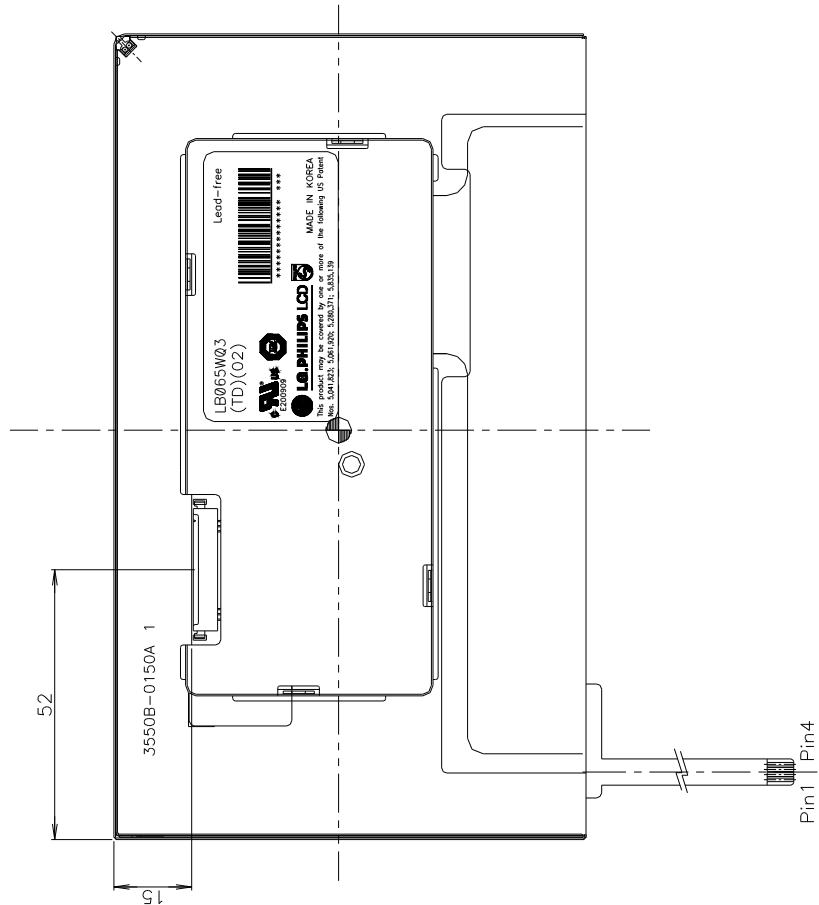

- UNSPECIFIED TOLERANCE IS $\pm 0.3\text{mm}$
- B/L CONNECTOR : BHR-03VS-1(JST) OR EQUIVALANT
MATING CONNECTOR : SM02(8.0)B-BHS-1-TB(JST) OR EQUIVALANT
- B/L WIRE COLOR & CN PIN ARRAY

PIN NO.	COLOR	VOLTAGE
1	PINK	HIGH
2	-	-
3	BLACK	LOW

- TOUCH SCREEN PANEL : BT-94134-2(FUSITSU)

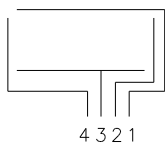

T/S CNT PIN ASSIGNMENT

PIN NO.	DESCRIPTION
1	Y1
2	X1
3	Y2
4	X2

Product Specification

8. Reliability Test

No.	Test Item	Test Condition	Remark
1	High Temperature Storage Test	Ta=60℃ 240hr	*8-1,2,3
2	Low Temperature Storage Test	Ta=-20℃ 240hr	*8-1,2,3
1	High Temperature Operation Test	Ta=50℃ 240hr	*8-1,2,3
2	High Temperature Operation Test (Without Touch Panel)	Tp=85℃ 240hr	*8-1,2,3
3	Low Temperature Operation Test	Ta=0℃ 240hr	*8-1,2,3
4	Low Temperature Operation Test (Without Touch Panel)	Ta=-30℃ 240hr	*8-1,2,3
5	High Temperature and High Humidity Storage Test	Ta=40℃ 90%RH 240hr	*8-1,2,3
6	Electro Static Discharge Test	-Panel Surface/Top_Case : 150pF ±15kV 150Ω (Direct Discharge, Five Times) -FPC Input Terminal : 100pF ±200V 0Ω	
7	Shock Test (No operation)	Half Sine Wave : 100G 6ms. Test Drop : One Direction 1 Drop/1 LCM.	
8	Vibration Test (No operation)	Random [10Hz↔300Hz, 1.0G. X, Y, Z Direction. Test Time: One Direction/1 LCM 30min.	
9	Thermal Shock Test	-20℃(0.5hr) ~ 60℃(0.5hr)/100cycles	

[Note 8-1] T_a = ambient temperature, T_p = panel surface temperature

[Note 8-2] In the reliability test, confirm performance after 1hr for test item 1-4 and 24hr for test item 5 leaving in room temperature.

[Note 8-3] In the standard condition, there shall be no practical problems that may affect the display function.

9. International Standard

9-1. Safety

- a) UL 60950, Third Edition, Underwriters Laboratories, Inc., Dated Dec. 11, 2000.
Standard for Safety of Information Technology Equipment, Including Electrical Business Equipment.
- b) CAN/CSA C22.2, No. 60950, Third Edition, Canadian Standards Association, Dec. 1, 2000.
Standard for Safety of Information Technology Equipment, Including Electrical Business Equipment.
- c) EN 60950 : 2000, Third Edition
IEC 60950 : 1999, Third Edition
European Committee for Electrotechnical Standardization(CENELEC)
European Standard for Safety of Information Technology Equipment Including Electrical Business Equipment.

9-2. EMC

- a) ANSI C63.4 "Methods of Measurement of Radio-Noise Emissions from Low-Voltage Electrical and Electrical Equipment in the Range of 9KHz to 40GHz". American National Standards Institute(ANSI), 1992
- b) C.I.S.P.R "Limits and Methods of Measurement of Radio Interface Characteristics of Information Technology Equipment." International Special Committee on Radio Interference.
- c) EN 55022 "Limits and Methods of Measurement of Radio Interface Characteristics of Information Technology Equipment". European Committee for Electrotechnical Standardization.(CENELEC), 1998
(Including A1: 2000)

Product Specification

10. Packing

10-1. Designation of Lot Mark

a) Lot Mark

A	B	C	D	E	F	G	H	I	J	K	L	M
---	---	---	---	---	---	---	---	---	---	---	---	---

A,B,C : SIZE(INCH)
E : MONTH
G : ASSEMBLY CODE

D : YEAR
F : FACTORY CODE
H ~ M : SERIAL NO.

Note

1. YEAR

Year	2001	2002	2003	2004	2005	2006	2007	2008	2009	2010
Mark	1	2	3	4	5	6	7	8	9	0

2. MONTH

Month	Jan	Feb	Mar	Apr	May	Jun	Jul	Aug	Sep	Oct	Nov	Dec
Mark	1	2	3	4	5	6	7	8	9	A	B	C

3. FACTORY CODE

Factory Code	LPL Gumi	LPL Nanjing	HEESUNG
Mark	K	C	D

4. SERIAL NO.

Mark	100001~199999, 200001~299999, 300001~399999,, A00001~A99999,, Z00001~Z99999
------	---

b) Location of Lot Mark

Serial No. is printed on the label. The label is attached to the backside of the LCD module.
This is subject to change without prior notice.

10-2. Packing Form

- a) Package quantity in one box : 44 pcs
- b) Box size : 492mm × 380mm × 165mm

11. Precaution

Please pay attention to the following when you use this TFT LCD module.

11-1. Mounting Precaution

- (1) You must mount a module using holes arranged in four corners or four sides.
- (2) You should consider the mounting structure so that uneven force(ex. twisted stress) is not applied to the module.
And the case on which a module is mounted should have sufficient strength so that external force is not transmitted directly to the module.
- (3) Please attach a transparent protective plate to the surface in order to protect touch panel.
Transparent protective plate should have sufficient strength in order to resist external force.
- (4) You should adopt radiation structure to satisfy the temperature specification.
- (5) Acetic acid type and chlorine type materials for the cover case are not desirable because the former generates corrosive gas of attacking the polarizer at high temperature and the latter causes circuit break by electro-chemical reaction.
- (9) Do not open the case because inside circuits do not have sufficient strength.
- (10) The metal case of a module should be contacted to electrical ground of your system.

11-2. Operating Precaution

- (1) The spike noise causes the mis-operation of circuits. It should be lower than following voltage :
 $V = \pm 200\text{mV}$ (Over and under shoot voltage)
- (2) Response time depends on the temperature.(In lower temperature, it becomes longer.)
- (3) Brightness depends on the temperature. (In lower temperature, it becomes lower.)
And in lower temperature, response time(required time that brightness is stable after turned on) becomes longer.
- (4) Be careful for condensation at sudden temperature change. Condensation makes damage to electrical contacted parts. And after fading condensation, smear or spot will occur.
- (5) When fixed patterns are displayed for a long time, remnant image is likely to occur.
- (6) Module has high frequency circuits. Sufficient suppression to the electromagnetic interference shall be done by system manufacturers. Grounding and shielding methods may be important to minimize the interference.
- (7) Do not operate it with a thing except a poly-acetal pen(tip R0.8mm or less) or a finger, especially those with hard or sharp tips such as a ball point pen or mechanical pencil.

11-3. Electrostatic Discharge Control

Since a module is composed of electronic circuits, it is not strong to electrostatic discharge. Make certain that treatment persons are connected to ground through wrist band etc. And don't touch interface pin directly.

11-4. Precautions for Strong Light Exposure

Strong light exposure causes degradation of polarizer and color filter.

11-5. Storage

When storing modules as spares for a long time, the following precautions are necessary.

- (1) Store them in a dark place. Do not expose the module to sunlight or fluorescent light. Keep the temperature between 5°C and 35°C at normal humidity.
- (2) Touch panel surface should not come in contact with any other object.
It is recommended that they be stored in the container in which they were shipped.

11-6. Handling Precautions for Protection Film

- (1) When the protection film is peeled off, static electricity may be generated.
This should be peeled off slowly and carefully by people who are electrically grounded and with well ion-blown equipment or in such a condition, etc.
- (2) The protection film is attached to the touch panel with a small amount of glue. If some stress is applied to rub the protection film against the touch panel during the time you peel off the film, the glue is apt to remain on the touch panel.
Please carefully peel off the protection film without rubbing it against the touch panel.
- (3) When the module with protection film attached is stored for a long time, sometimes there remains a very small amount of glue still on the touch panel after the protection film is peeled off.
- (4) You can remove the glue easily. When the glue remains on the touch panel surface or its vestige is recognized, please wipe them off with absorbent cotton waste or other soft material like chamois soaked with normal-hexane.