

**Product Specification**

# SPECIFICATION FOR APPROVAL

- ( ● ) Preliminary Specification
- (   ) Final Specification

<b>Title</b>	<b>7.0"W (480 X RGB X 234) TFT-LCD</b>
--------------	--

BUYER	
MODEL	

SUPPLIER	LG.Philips LCD Co., Ltd.
MODEL	LB070W02
SUFFIX	TME2

**\*Without Tcon**

SIGNATURE	DATE
/	_____
/	_____
/	_____

APPROVED BY	DATE
H.S. SOO /G.Manager	_____
<b>REVIEWED BY</b>	
S.H. JUNG /Manager	_____
<b>PREPARED BY</b>	
S.H. CHO /Engineer	_____

**Product Engineering Dept.  
LG. Philips LCD Co., Ltd**

**Product Specification****CONTENTS**

NO.	ITEM	PAGE
0	Record of Revisions	3
1	Summary	4
2	Features	4
3	General Specification	4
4	Interface (Input Terminal)	5
5	Absolute Maximum Ratings	7
6	Electrical Characteristics	8
7	Electro-optical Characteristics	14
8	Mechanical Characteristics	17
9	Reliability Test	19
10	International Standards	20
11	Packing	21
12	Precautions	22



**Product Specification**

**1. Summary**

This module utilizes amorphous silicon thin film transistors and a 16:9 aspect ratio. A 7.0" active matrix liquid crystal display allows full color to be displayed.

The applications are Portable DVD, Multimedia applications and others AV system.

**2. Features**

- Utilizes a panel with a 16:9 aspect ratio, which makes the module suitable for use in wide-screen systems.
- The 7.0" screen produces a high resolution image that is composed of 112,320 pixel elements in a stripe arrangement.
- Wide viewing angle technology is employed.  
[The most suitable viewing direction is in the 6 o'clock direction.]
- By adopting an active matrix drive, a picture with high contrast is realized.
- This Board Assembly is accomplished through the use of COG mounting technology.
- By adopting a high aperture panel, high transmittance color filter and high transmission polarizing plates, transmittance ratio is realized.

**3. General Specification**

CHARACTERISTIC ITEM	SPECIFICATION
Video Signal Interface	Analog Video Interface
Display Technology	a-Si TFT active matrix
Display Mode	TN Type Full Color / Transmitting Type / Normally White
Screen Size (Diagonal)	7.0" (17.67cm)
Outline Dimension	164.9mm (W) X 100mm (H) X 5.7mm (D)
Active Area	154.08mm (W) X 86.58mm (H)
Number Of dots	480(H) X 3(R,G,B) X 234(V)
Dot Pitch	0.107mm (W) X 0.370mm (H)
Color Filter Array	RGB vertical stripes
Weight	170 g (Max)
Backlight	CCFL with 3 wave-length spectrum (L Type)
Surface Treatment	Anti-Glare Treatment

**Product Specification**
**4. Interface (Input terminal)**

## 1&gt; TFT-LCD Panel Driving Part

Pin No.	SYMBOL	FUNCTION	REMARK
1	GND	Ground for logic circuit	
2	VCC	Supply voltage of logic control circuit for scan driver	
3	VGL	Negative power for scan driver	
4	VGH	Positive power for scan driver	
5	STVR	Open	Forced Up to Down Sampling Mode
6	STVL	Vertical start pulse	
7	CLK	Shift clock input for scan driver	
8	U/D	Open	Forced Up to Down Sampling Mode
9	GOE	Output enable input for scan driver(GOE)	H: enable / L:disable
10	VCOM	Common electrode driving signal	
11	VCOM	Common electrode driving signal	
12	L/R	LEFT/RIGHT scan control input	See 6-3> P.9
13	MOD	Sequential sampling and simultaneous sampling setting	
14	SOE	Output enable input for data driver(INH)	
15	STHL	Start pulse for horizontal scan line	
16	STHR	Start pulse for horizontal scan line	
17	CPH3	Sampling and shifting clock pulse for data driver	
18	CPH2	Sampling and shifting clock pulse for data driver	
19	CPH1	Sampling and shifting clock pulse for data driver	
20	VCC	Supply voltage of logic control circuit for data driver	
21	GND	Ground for logic circuit	
22	VR	Alternated video signal input(Red)	
23	VG	Alternated video signal input(Green)	
24	VB	Alternated video signal input(Blue)	
25	AVDD	Supply voltage for analog circuit	
26	AVSS	Ground for analog circuit	

\*\*The matching connector part number is GF053-26S-LSS(Bottom Contact Type) or GF055-26S-LSS (Top Contact Type) manufactured by LG Cable Ltd. or equivalent.

**Product Specification**

2> Backlight Fluorescent Tube Driving Part

Pin No.	SYMBOL	FUNCTION	REMARK
1	HV	Power Supply For Lamp [High Voltage Side]	[Note 4-1]
2	LV	Power Supply For Lamp [Low Voltage Side]	[Note 4-2]

The backlight interface connector is a model **BHSR-02VS-1** manufactured by JST or a model **1674817-1** manufactured by AMP. The matching connector part number is **SM02B-BHSS-1-TB** manufactured by JST or equivalent.

[Note 4-1] The wire color of high voltage side is pink.

[Note 4-2] The wire color of low voltage side is white. Connect the low voltage side of the DC/AC inverter used to drive the fluorescent tube to GND of the inverter circuit.

**Product Specification**
**5. Absolute Maximum Ratings**

PARAMETER	SYMBOL	CONDITION	MIN.	MAX.	UNIT	REMARK
Logic Voltage	VDD1	$T_a=25^{\circ}\text{C}$	-0.5	6.0	V	
Source Driver Voltage	VDD2	$T_a=25^{\circ}\text{C}$	-0.5	6.0	V	
Digital Input Signals	$V_{DI}$	$T_a=25^{\circ}\text{C}$	-0.5	$VDD1+0.5$	V	[Note 5-1]
Analog Input Signals	$V_{AI}$	$T_a=25^{\circ}\text{C}$	-0.5	$VDD2+0.5$	V	[Note 5-2]
Gate Driver High Supply Voltage	VGH	$T_a=25^{\circ}\text{C}$	-0.5	28	V	
Gate Driver Internal Negative Supply Voltage	VEE	$T_a=25^{\circ}\text{C}$	-16	0.5	V	
Gate Driver Low Supply Voltage	VGL	$T_a=25^{\circ}\text{C}$	$VEE-0.3$	$VEE+7.0$	V	
Storage Temperature	$T_{st}$	-	TBD	TBD	$^{\circ}\text{C}$	[Note 5-3,4]
Operating Temperature (Ambient Temperature)	$T_a$	-	TBD	TBD	$^{\circ}\text{C}$	[Note 5-3,4,5,6]

[Note 5-1] DS, U/D, STV, CLK, OE, DSOE, STH1, STH2, U/R, SOE, CPH1, CPH2, CPH3

[Note 5-2] VR, VG, VB

[Note 5-3] This rating applies to all parts of the module and should not be exceeded.

[Note 5-4] Maximum wet-bulb temperature is  $60^{\circ}\text{C}$ . Condensation of dew must be avoided as electrical current leaks will occur, causing a degradation of performance specifications.

[Note 5-5] The operating temperature only guarantees operation of the circuit. The contrast, response speed, and the other specification related to electro-optical display quality is determined at the room temperature,  $T_a \approx 25^{\circ}\text{C}$ .

[Note 5-6] Ambient temperature when the backlight is lit (reference value).

Product Specification

6. Electrical Characteristics

1> Recommended Operating Conditions

◆ TFT-LCD Panel Driving Section

T<sub>s</sub>=25 °C

PARAMETER		SYMBOL	MIN.	TYP.	MAX.	UNIT	REMARK
Logic Supply Voltage		VDD1	3.0	5.0	5.2	V	
Digital Input Signal	High Level	V <sub>IH</sub>	0.8VDD1	-	VDD1	V	
	Low Level	V <sub>IL</sub>	0	-	0.2VDD1	V	
Source Driver Supply Voltage		VDD2	4.5	5.0	5.5	V	
Gate Driver	High Supply Voltage	VGH	16.0	16.5	17.0	V	
	Low Supply Voltage	VGL	-10.5	-10	-9.5	V	
Analog Video Signal Input Voltage		V <sub>VI</sub>	AGND+1.0	-	VDD2-1.0	V	
Color Filter Substrate Voltage	AC Component	VCOM <sub>AC</sub>	4.0	5.0	6.0	V <sub>p-p</sub>	
	DC Component	VCOM <sub>DC</sub>	1.5	1.75	2.0	V	[Note 1]

[Note 1] This value should be tuned for optimal display quality of each panel.

\*\*\*\*\* Cautionary Matter : When applying or disconnecting power, please be sure that such action is sequentially carried out for all power supplies. In addition, apply input signals only after power has been turned on.

-Source Driver :

Turn on power to VDD1 and VDD2 in this order.  
Turn off power in the reverse order.

-Gate Driver :

Turn on power to VDD1, VGL and VGH in this order.  
Turn off power in the reverse order.



**Product Specification**

PARAMETER	SYMBOL	MIN.	TYP.	MAX.	UNIT	REMARK
Logic Supply Current	$I_{DD1}$	-	-	5.0	mA	VDD1 = 5.0V
Source Driver Supply Current	$I_{DD2}$	-	-	50	mA	VDD2 = 5.0V
Gate Driver High Supply Current	$I_{GH}$	-	-	0.5	mA	VGH=16.5V
Gate Driver Low Supply Current	$I_{GL}$	-	-	15	mArms	VGL <sub>DC</sub> =-10V

**◆ Backlight Driving Section**

PARAMETER	SYMBOL	MIN.	TYP.	MAX.	UNIT	REMARK
Lamp Current	$I_{BL}$	3.0	6.0	7.0	mArms	
Lamp Voltage	$V_{BL}$	567 (7.0mA)	594 (8.0mA)	633 (3.0mA)	Vrms	±10[%]
Lamp Power Consumption	$P_{BL}$		3.56		W	@ Typ. Current
Lamp Frequency	$f_{BL}$	45	-	60	kHz	*1
		45	-	80		*2
Kick-Off Voltage (*3)	$V_S$	-	-	830	Vrms	$T_a=25^{\circ}C$
		-	-	940	Vrms	$T_a=0^{\circ}C$
Discharge Stabilization Time	$T_S$	-	-	3	Minutes	*4
Life Time	-	20,000	-	-	Hours	*5

Product Specification

- \* 1 : This frequency range means the range to keep within  $\pm 10\%$  change of electrical and optical characteristics.
- \* 2 : This frequency range means not affecting to lamp life and reliability characteristics.  
(The lamp frequency should be selected as different as possible from display horizontal synchronous signal (Including harmonic frequency of this scanning frequency) to avoid "Beat" interference which may be observed on the screen as horizontal stripes like moving wave. This phenomenon is caused by interference between lamp (CCFL) lighting frequency and LCD horizontal synchronous signal.)
- \* 3 : The "MAX" of "Kick-Off Voltage" means the minimum voltage for inverter to turn on the CCFL normally in the LCD module. However this isn't the values that we can assure stability of starting lamp on condition that the module is installed in your set.  
It should be careful that "Kick-Off Voltage" is changed by an increase of stray capacitance in your set, inverter method, value of ballast capacitor in your inverter and so on.  
Especially, the value of "Kick-Off Voltage" is higher in low temperature condition than in normal temperature condition, because impedance of CCFL is increased.
- \* 4 : The time needed to achieve not less than 95% brightness of the center part of lamp.  
The brightness of the lamp after being lighted for 5 minutes is defined as 100%.
- \* 5 : "Life time" is defined as the time the lamp brightness decreases to 50% from original brightness at  $I_{BL}=TYP$ ; continuous lighting,  $T_a=25^\circ C$ .

Requirements for a system inverter design, which is intended to have a better display performance, a better power efficiency and a more reliable lamp, are following. It shall help increase the lamp lifetime and reduce leakage current. Inverter should be designed to be subject to the conditions below

- A. The asymmetry rate of the inverter waveform should be less than 10%.
  - B. The distortion rate of the waveform should be within  $\sqrt{2} \pm 10\%$ .
- \* Inverter output waveform had better be more similar to ideal sine wave.

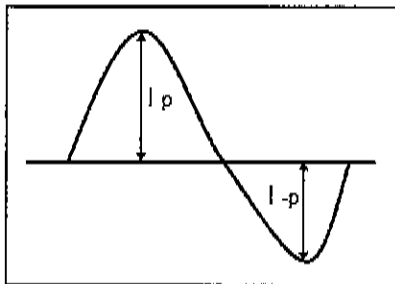

\* Asymmetry rate:

$$(I_p - I_{-p}) / I_{rms} * 100\%$$

•Distortion rate:

$$I_p \text{ (or } I_{-p}) / I_{rms}$$

- C. There should not be any spikes in the waveform.
- D. Lamp current should not exceed the "MAX" value under the "Operating Temperature" (it is prohibited to exceed the "MAX." value even if it is operated in the guaranteed temperature).  
When lamp current exceed the maximum value for a long time, it may cause a smoking and ignition.  
Therefore, it is recommended that the inverter have the current limited circuit that is used as a protection circuit and/or the lamp current-controlled inverter.

- \* Do not attach a conducting tape to lamp connecting wire.  
If the lamp wire attaches to a conducting tape, TFT-LCD Module has a low luminance and the inverter has abnormal action. Because leakage current is occurred between lamp wire and conducting tape.

**Product Specification**
**2> Timing Characteristics of input signals**

	PARAMETER	SYMBOL	MIN.	TYP.	MAX.	UNIT	REMARK
SOURCE	Clock cycle time	$T_{cph}$	100	-	2000	ns	CPHn
	CPHn pulse duty	$T_{cwh}$	40	-	60	%	CPHn
	CPHn phase delay	$T_{c12}$ $T_{c23}$ $T_{c31}$	20	-	$T_{cph}/2$	ns	CPH1-CPH2 CPH2-CPH3 CPH3-CPH1
	Set-up time of analog signals	$T_{asu}$	60	-	-	ns	VA,VB,VC-CPHn
	Hold time of analog signals	$T_{ahd}$	40	-	-	ns	CPHn-VA,VB,VC
	STHn set-up time	$T_{su}$	20	-	-	ns	STHn-CPHn
	STHn hold time	$T_{hd}$	10	-	-	ns	CPHn-STHn
	Propagation delay of STHn	$T_{phl}$	10	35	50	ns	CL=25pF
	Sample and hold disable time	$T_{dis}$	8	-	-	us	OE-STHn
	SOE pulse width	$T_{woe}$	1	-	-	$T_{cph}$	
GATE	Clock Frequency	$f_{cl}$	-	-	500	KHz	
	Clock Pulse Width	$T_{cwh}$ $T_{cwl}$	500	-	-	ns	
	OE Disable Time	$T_{woeb}$	1000	-	-	ns	
	STV Setup Time	$T_{sustv}$	200	-	-	ns	
	STV Hold Time	$T_{hdstv}$	200	-	-	ns	
	Output Delay to CL	$T_{pdlr}$	-	-	800	ns	CL=300pF
	Output Delay to CL	$T_{pdli}$	-	-	800	ns	CL=300pF
	Output Delay to OE	$T_{pdzr}$	-	-	800	ns	CL=300pF
Output Delay to OE	$T_{pdzi}$	-	-	800	ns	CL=300pF	

**3> Scanning Mode Selection ( Reference position : @ Input terminal )**

MODE	L/R	U/D	\$THL	\$THR	\$TV	REMARK
Normal Mode	H	H	Signal Output	Signal Input	Input	See P. 15 (the figure of [Note 7-3])
Left/Right Reverse Mode	L	H	Signal Input	Signal Output	Input	

\*\*\*\* H(High Level) =VDD1 , L(Low Level)=DGND

Product Specification

Timing for a Source Driver

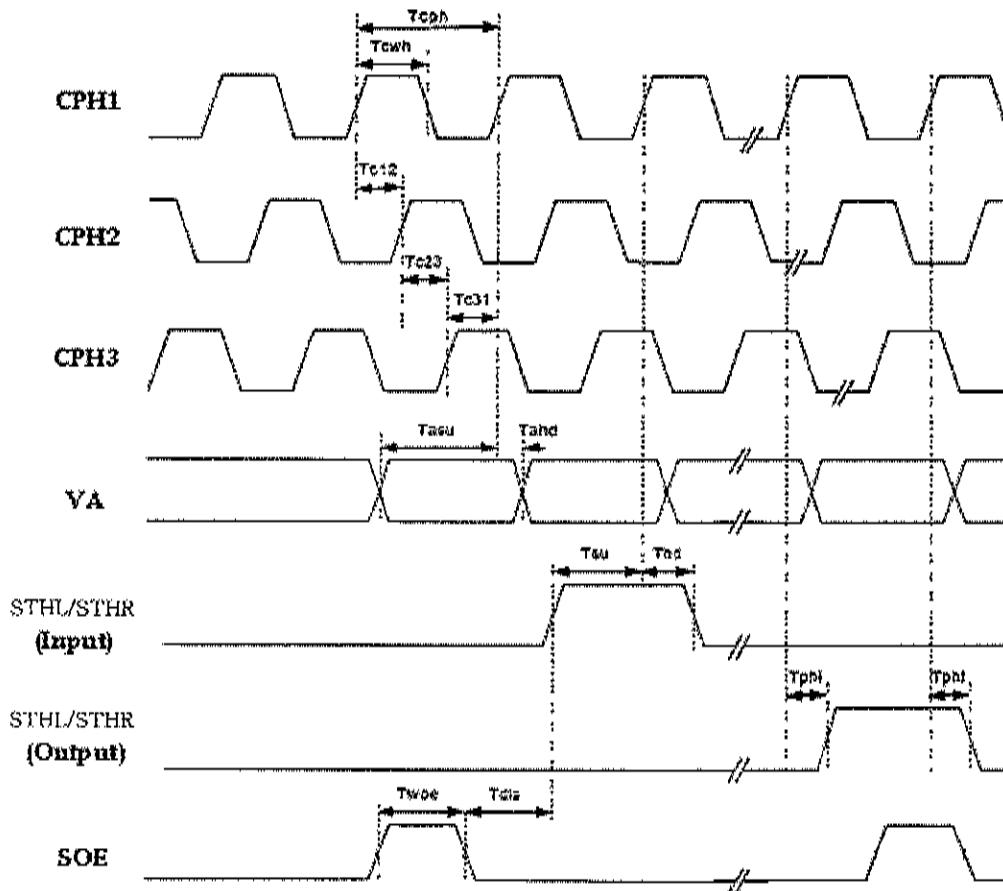

• Remark : The sample-and-hold circuits are switched and the outputs are started with new data at the rising edge of SOE.

“ For  $T_{twoe}$  period, shift register in source driver are reset internally.”

Product Specification

Switching Characteristics Waveform for Gate Driver

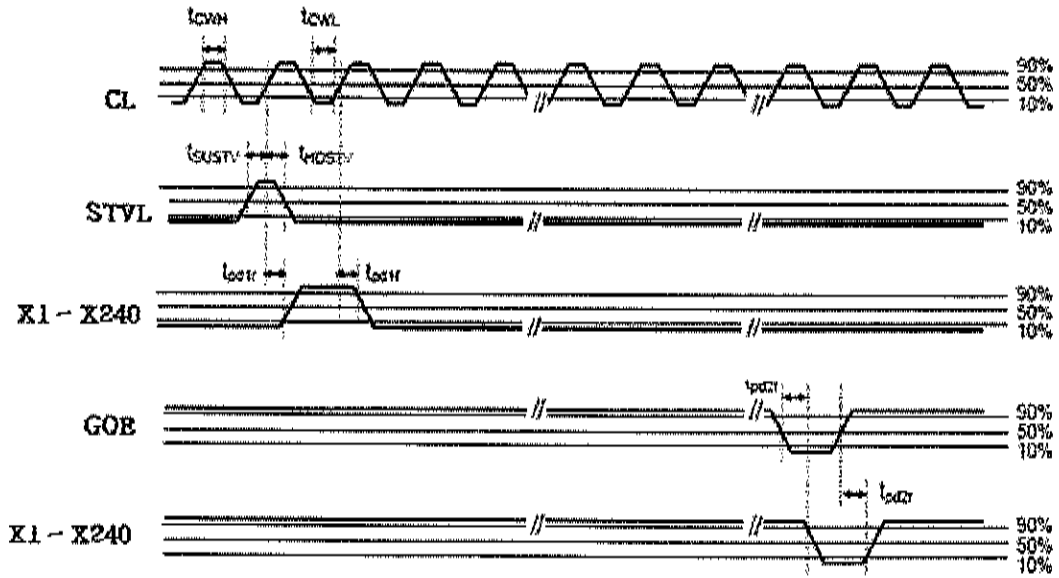

**Product Specification**

**7. Electro-optical Characteristics**

T<sub>a</sub>=25°C

PARAMETER		SYMBOL	CONDITION	MIN.	TYP.	MAX.	UNIT	REMARK
Luminance		Y	I <sub>BL</sub> =6mA <sub>rms</sub>	190	220	-	cd/m <sup>2</sup>	[Note 7-1]
Contrast Ratio		CR	Optimal	300	400	-	-	[Note 7-2]
White Color Chromaticity		W <sub>x</sub>	-	288	318	348	-	[Note 7-1]
		W <sub>y</sub>		298	328	358	-	
Viewing Angle	φ=180°	Θl	CR≥10	60	65	-	°	[Note 7-2] [Note 7-3]
	φ=0°	Θr		60	65	-	°	
	φ=90°	Θu		40	45	-	°	
	φ=270°	Θd		50	55	-	°	
Response Time	Rise	τ <sub>r</sub>	Θ=0°	-	10	20	ms	[Note 7-4]
	Fall	τ <sub>d</sub>		-	20	30	ms	

**Product Specification**

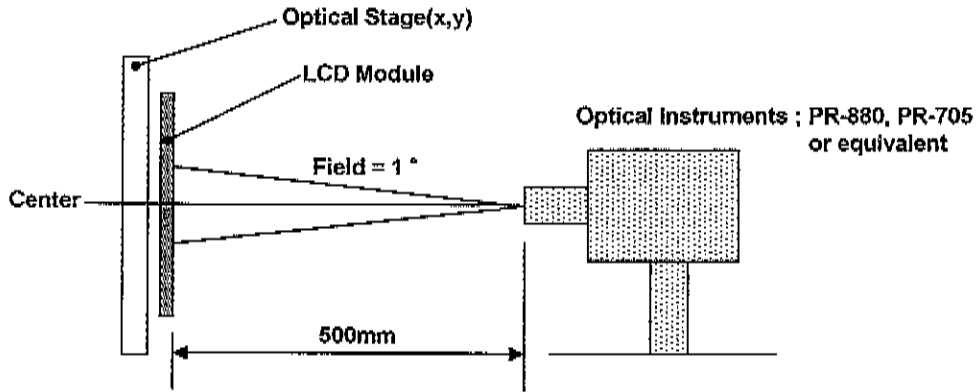

- Measuring Condition ;
- Measuring surroundings : Dark Room
  - Measuring temperature :  $T_a=25^{\circ}\text{C}$
  - Adjust operating voltage to get optimum contrast at the center of the display.
  - Measured value at the center point of LCD panel after more than 30 minutes while backlight turning on.

[Note 7-1] Measured on the center area of the panel by PHOTO RESEARCH photometer PR-880.

[Note 7-2] Contrast ratio is defined as follows ;

$$\text{Contrast Ratio(CR)} = \frac{\text{Photo detector output with LCD being "white"}}{\text{Photo detector output with LCD being "black"}}$$

[Note 7-3] Viewing angle range is defined as follows;

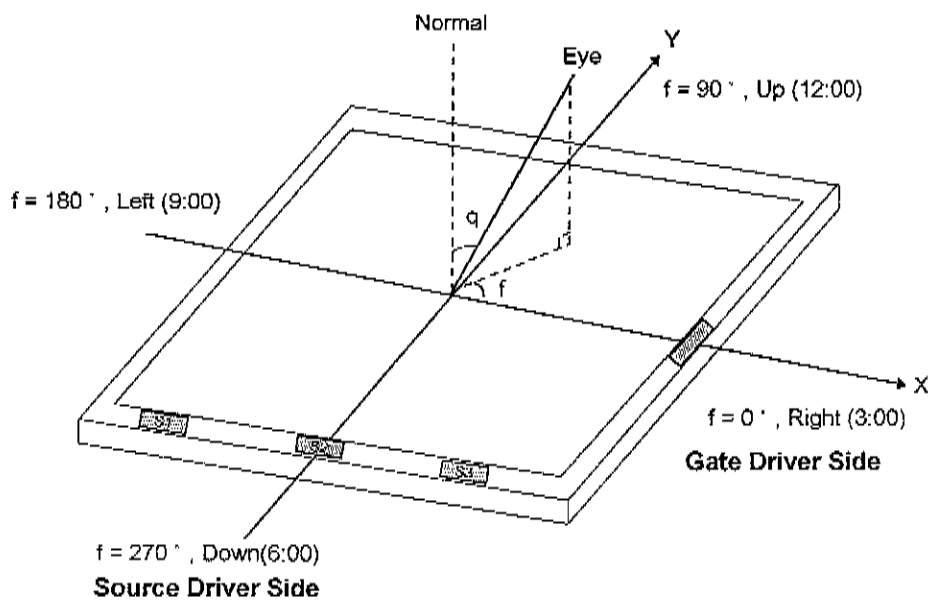

**Product Specification**

[Note 7-4]

Response time is obtained by measuring the transition time of photo detector output, when input signals are applied so as to make the area "black" to and from "white".

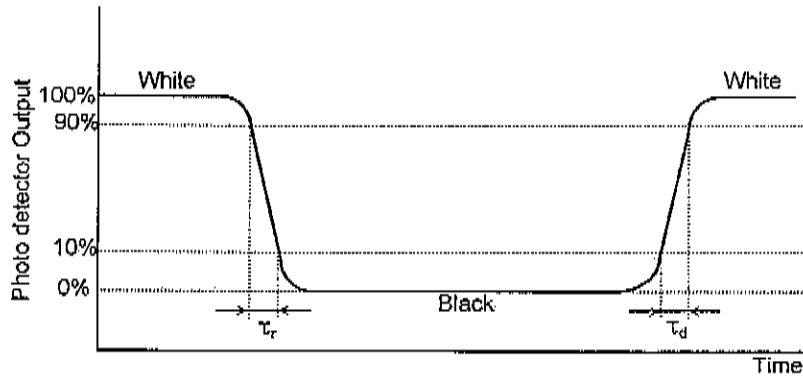



**Product Specification**

**8. Mechanical Characteristics**

PARAMETER	SPECIFICATION		UNIT	REMARK
Outline Dimension	Width	164.9	mm	
	Height	100	mm	
	Depth	5.7 (TYP)	mm	
Active Display Area	Width	154.08	mm	
	Height	86.58	mm	
Weight	170 (Max.)		g	
Surface Treatment	Anti-Glare Treatment		-	

**Product Specification**

**[ Outline Dimension ]**

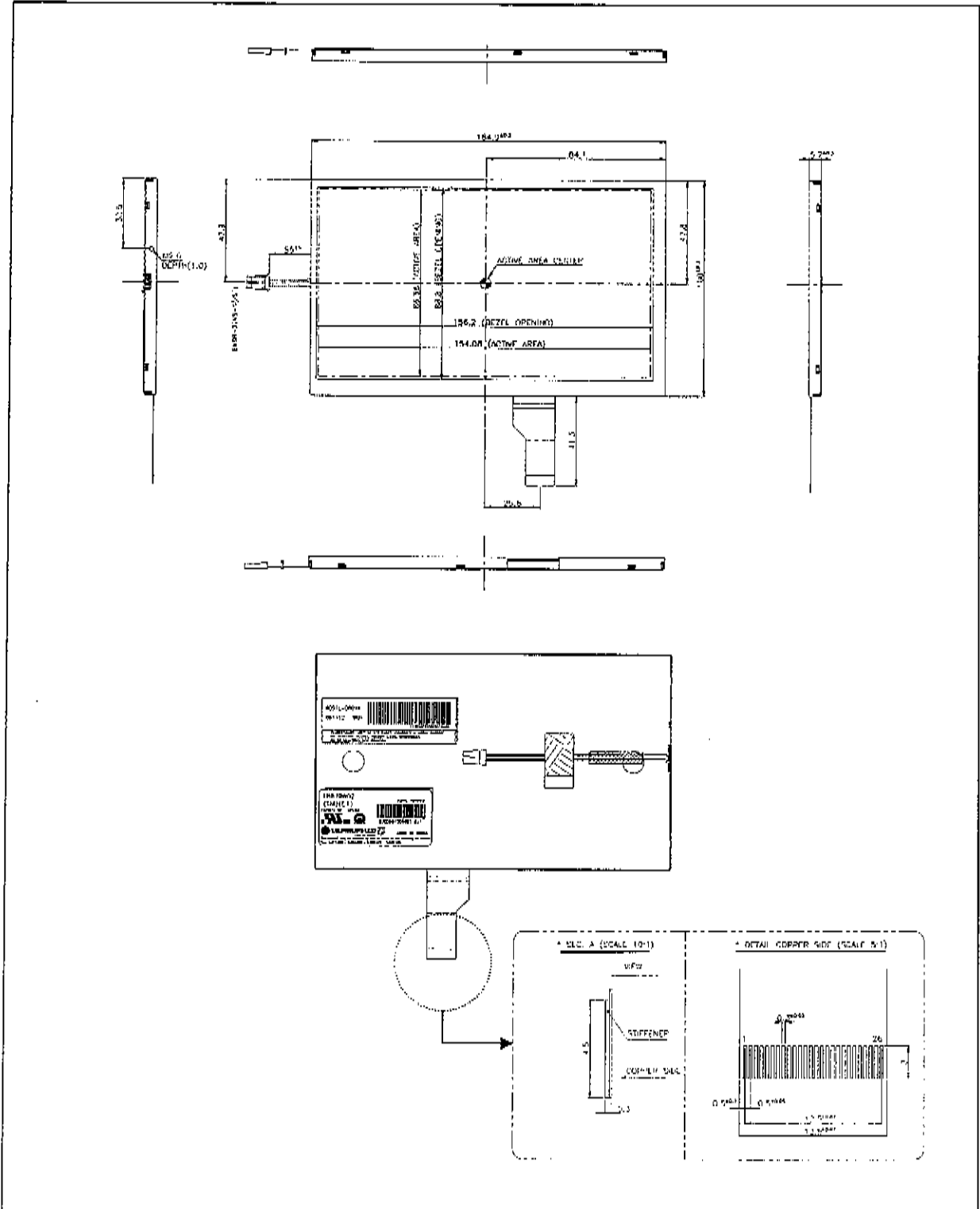

**Product Specification**

**9. Reliability Test**

No.	Test Items	Test Condition	REMARK
1	High Temperature Storage Test	Ta=70°C 240h	[Note 9-1,2,3]
2	Low Temperature Storage Test	Ta=-20°C 240h	[Note 9-1,2,3]
3	High Temperature Operation Test	Ta=60°C 240h	[Note 9-1,2,3]
4	Low Temperature Operation Test	Ta=-10°C 240h	[Note 9-1,2,3]
5	High Temperature and High Humidity Operation Test	Ta=50°C 80%RH 240h	[Note 9-1,2,3]
6	Electro Static Discharge Test	-Panel Surface/Top_Case : 150pF, 150Ω (Air : ±15kV . Contact : ±8kV ) -FPC input terminal : 100pF ±200V 0Ω	
7	Shock Test (non-operating)	Half sine wave, 80G, 11ms 3 times shock of each six faces	
8	Vibration Test (non-operating)	Sine wave, 10 ~ 500 ~ 10Hz, 1.5G, 0.37oct/min 3 axis, 1hour/axis	
9	Thermal Shock Test	-10°C(0.5h) ~ 60°C(0.5h) / 100 cycles	

[Note 9-1] T<sub>a</sub> = Ambient Temperature

[Note 9-2] In the Reliability Test, Confirm performance after leaving in room temp.

[Note 9-3] In the standard condition, there shall be no practical problems that may affect the display function.

**Product Specification****10. International Standards****10-1. Safety**

- a) UL 60950-1:2003, First Edition, Underwriters Laboratories, Inc., Standard for Safety of Information Technology Equipment.
- b) CAN/CSA C22.2, No. 60950-1-03 1<sup>st</sup> Ed. April 1, 2003, Canadian Standards Association, Standard for Safety of Information Technology Equipment.
- c) EN 60950-1:2001, First Edition, European Committee for Electrotechnical Standardization(CENELEC) European Standard for Safety of Information Technology Equipment.

**10-2. EMC**

- a) ANSI C63.4 "Methods of Measurement of Radio-Noise Emissions from Low-Voltage Electrical and Electrical Equipment in the Range of 9kHz to 40GHz." American National Standards Institute(ANSI), 1992
- b) C.I.S.P.R "Limits and Methods of Measurement of Radio Interface Characteristics of Information Technology Equipment." International Special Committee on Radio Interference.
- c) EN 55022 "Limits and Methods of Measurement of Radio Interface Characteristics of Information Technology Equipment." European Committee for Electrotechnical Standardization.(CENELEC), 1998 ( Including A1: 2000 )

**Product Specification**

**11. Packing**

**11-1. Designation of Lot Mark**

a) Lot Mark

A	B	C	D	E	F	G	H	I	J	K	L	M
---	---	---	---	---	---	---	---	---	---	---	---	---

A,B,C : SIZE(INCH)  
E : MONTH

D : YEAR  
F ~ M : SERIAL NO.

Note

1. YEAR

Year	2001	2002	2003	2004	2005	2006	2007	2008	2009	2010
Mark	1	2	3	4	5	6	7	8	9	0

2. MONTH

Month	Jan	Feb	Mar	Apr	May	Jun	Jul	Aug	Sep	Oct	Nov	Dec
Mark	1	2	3	4	5	6	7	8	9	A	B	C

b) Location of Lot Mark

Serial No. is printed on the label. The label is attached to the backside of the LCD module.  
This is subject to change without prior notice.

**11-2. Packing Form**

a) Package quantity in one box : 36 pcs

b) Box Size(mm) : 475(L)×348(W)×182(H)

**Product Specification****12. PRECAUTIONS**

Please pay attention to the following when you use this TFT LCD module.

**12-1. MOUNTING PRECAUTIONS**

- (1) You must mount a module using hole arranged in the side.
- (2) You should consider the mounting structure so that uneven force(ex. Twisted stress) is not applied to the module.  
And the case on which a module is mounted should have sufficient strength so that external force is not transmitted directly to the module.
- (3) Please attach a transparent protective plate to the surface in order to protect the polarizer.  
Transparent protective plate should have sufficient strength in order to resist external force.
- (4) You should adopt radiation structure to satisfy the temperature specification.
- (5) Acetic acid type and chlorine type materials for the cover case are not desirable because the former generates corrosive gas of attacking the polarizer at high temperature and the latter causes circuit break by electro-chemical reaction.
- (6) Do not touch, push or rub the exposed polarizers with glass, tweezers or anything harder than HB pencil lead. And please do not rub with dust clothes with chemical treatment.  
Do not touch the surface of polarizer for bare hand or greasy cloth.(Some cosmetics deteriorate the polarizer.)
- (7) When the surface becomes dusty, please wipe gently with absorbent cotton or other soft materials like chamois soaks with petroleum benzine. Normal-hexane is recommended for cleaning the adhesives used to attach front / rear polarizers. Do not use acetone, toluene and alcohol because they cause chemical damage to the polarizer.
- (8) Wipe off saliva or water drops as soon as possible. Their long time contact with polarizer causes deformations and color fading.
- (9) Do not open the case because inside circuits do not have sufficient strength.
- (10) The metal case of a module should be contacted to electrical ground of your system.

**12-2. OPERATING PRECAUTIONS**

- (1) The spike noise causes the mis-operation of circuits. It should be lower than following voltage :  
 $V = \pm 200\text{mV}$ (Over and under shoot voltage)
- (2) Response time depends on the temperature.(In lower temperature, it becomes longer.)
- (3) Brightness depends on the temperature. (In lower temperature, it becomes lower.)  
And in lower temperature, response time(required time that brightness is stable after turned on) becomes longer.
- (4) Be careful for condensation at sudden temperature change. Condensation makes damage to polarizer or electrical contacted parts. And after fading condensation, smear or spot will occur.
- (5) When fixed patterns are displayed for a long time, remnant image is likely to occur.
- (6) Module has high frequency circuits. Sufficient suppression to the electromagnetic interference shall be done by system manufacturers. Grounding and shielding methods may be important to minimize the interference.

**Product Specification****12-3. ELECTROSTATIC DISCHARGE CONTROL**

Since a module is composed of electronic circuits, it is not strong to electrostatic discharge. Make certain that treatment persons are connected to ground through wrist band etc. And don't touch interface pin directly.

**12-4. PRECAUTIONS FOR STRONG LIGHT EXPOSURE**

Strong light exposure causes degradation of polarizer and color filter.

**12-5. STORAGE**

When storing modules as spares for a long time, the following precautions are necessary.

- (1) Store them in a dark place. Do not expose the module to sunlight or fluorescent light. Keep the temperature between 5°C and 35°C at normal humidity.
- (2) The polarizer surface should not come in contact with any other object.  
It is recommended that they be stored in the container in which they were shipped.

**12-6. HANDLING PRECAUTIONS FOR PROTECTION FILM**

- (1) When the protection film is peeled off, static electricity is generated between the film and polarizer. This should be peeled off slowly and carefully by people who are electrically grounded and with well ion-blown equipment or in such a condition, etc.
- (2) The protection film is attached to the polarizer with a small amount of glue. If some stress is applied to rub the protection film against the polarizer during the time you peel off the film, the glue is apt to remain on the polarizer.  
Please carefully peel off the protection film without rubbing it against the polarizer.
- (3) When the module with protection film attached is stored for a long time, sometimes there remains a very small amount of glue still on the polarizer after the protection film is peeled off.
- (4) You can remove the glue easily. When the glue remains on the polarizer surface or its vestige is recognized, please wipe them off with absorbent cotton waste or other soft material like chamois soaked with normal-hexane.