

Product Specification

SPECIFICATION FOR APPROVAL

- () Preliminary Specification
 (●) Final Specification

Title	7.0" WVGA (800 x RGB x 480) TFT LCD
-------	-------------------------------------

BUYER	
MODEL	W212

SUPPLIER	LG Display Co., Ltd.
*MODEL	LB070WV3
Suffix	SD01

SIGNATURE	DATE
/	_____
/	_____
/	_____

Please return 1 copy for your confirmation with your signature and comments.

SIGNATURE	DATE
J.D. KIM / G.Manager	_____
REVIEWED BY	_____
C.S. SO / S. Manager	_____
PREPARED BY	_____
J.Y. KANG / Engineer	_____

Products Engineering Dept.
LG Display Co., Ltd

Product Specification

Contents

No	ITEM	Page
	COVER	1
	CONTENTS	2
	RECORD OF REVISIONS	3
1	GENERAL DESCRIPTION	4
2	ABSOLUTE MAXIMUM RATINGS	5
3	ELECTRICAL SPECIFICATIONS	
3-1	ELECTRICAL CHARACTERISTICS	6
3-2	INTERFACE CONNECTIONS	8
3-3	SIGNAL TIMING SPECIFICATIONS	9
3-4	SIGNAL TIMING WAVEFORMS	11
3-5	COLOR INPUT DATA REFERENCE	12
3-6	POWER SEQUENCE	13
3-7	Thermistor	14
4	OPTICAL SPECIFICATIONS	15
5	MECHANICAL CHARACTERISTICS	19
6	RELIABILITY	22
7	INTERNATIONAL STANDARDS	
7-1	SAFETY	23
7-2	EMC	23
8	PACKING	
8-1	DESIGNATION OF LOT MARK	24
8-2	PACKING FORM	24
9	PRECAUTIONS	25

1. General Description

The LB070WV3 is a Color Active Matrix Liquid Crystal Display with an integral WHITE LED backlight system. The matrix employs a-Si Thin Film Transistor as the active element. It is a transmissive type display operating in the normally white mode. This TFT-LCD has 7.0 inches diagonally measured active display area with WVGA resolution(800 horizontal by 480 vertical pixel array). Each pixel is divided into Red, Green and Blue sub-pixels or dots which are arranged in vertical stripes. Gray scale or the brightness of the sub-pixel color is determined with a 6-bit gray scale signal for each dot, thus, presenting a palette of more than 262,144 colors.

The LB070WV3 has been designed to apply the interface method that enables low power, high speed, low EMI.

The LB070WV3 is intended to support applications where thin thickness, low power are critical factors and graphic displays are important. In combination with the vertical arrangement of the sub-pixels, the LB070WV3 characteristics provide an excellent flat display.

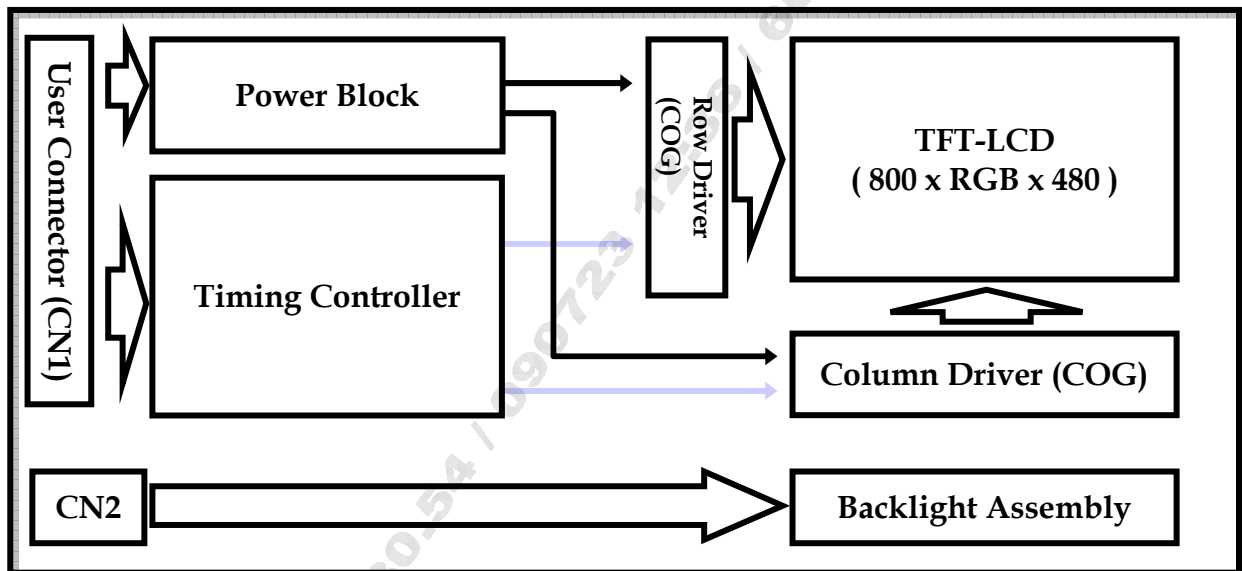

General Features

Active Screen Size	7.0 inches diagonal
Outline Dimension	170.0 (H) × 109.6 (V) × 15.3(D) mm (Typ.)
Pixel Pitch	0.1905 mm × 0.1905 mm
Pixel Format	800 horiz. by 480 vert. Pixels RGB strip arrangement
Color Depth	6-bit, 262,144 colors
Luminance, White	470 cd/m ² (Min.) [with LCF, Enhanced Single-Peak]
Power Consumption	Total 8.8 Watt(Typ.) [LCM circuit 1.68 Watt(Typ.)+B/L 7.12 Watt(Typ.)]
Weight	325g(Typ.) 375g (Max.)
Display Operating Mode	Transmissive mode, normally black
Surface Treatment	Anti-glare/Anti-reflection treatment of the front polarizer

2. Absolute Maximum Ratings

The following are maximum values which, if exceeded, may cause faulty operation or damage to the unit.

Table 1. ABSOLUTE MAXIMUM RATINGS

Parameter	Symbol	Values		Units	Notes	
		Min	Max			
Power Input Voltage	VCC	0.0	3.6	Vdc	at 25 ± 5°C	
Storage Temperature	HST	-40	105	°C	1	
Operating Temperature	Surface Of Panel	T _p	-40	95	°C	1,2
	Ambient	T _a	-40	80	°C	1,2,3

Notes :

1. Maximum wet-bulb temperature is 58°C. Condensation of dew must be avoided, because it may cause electrical current leakage, and deterioration of performance and quality.
2. The operating temperature means that LCD Module guarantees operation of the circuit.
All the contents of Electro-optical specifications are guaranteed under the room temperature condition.
3. This temperature is ambient temperature with regard to the heat which is generated under operation of circuit and backlight on.(reference value)

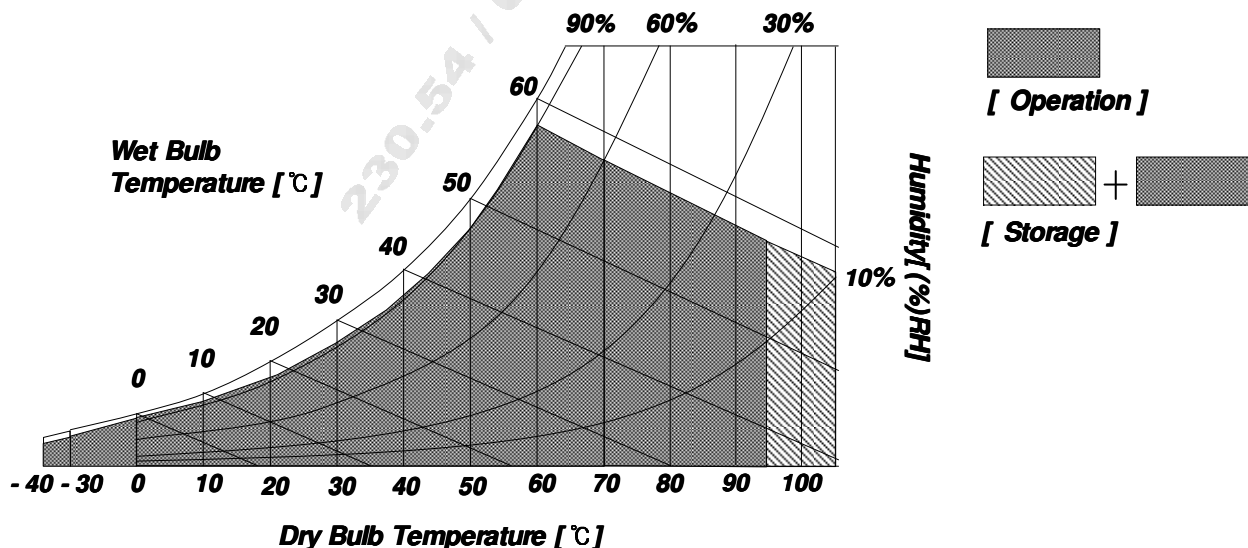

Product Specification

3. Electrical Specifications

3-1. Electrical Characteristics

The LB070WV3 requires two power inputs. One is employed to power the LCD electronics and to drive the TFT array and liquid crystal. The second input which powers the LED, is typically generated by an LED-driver. The LED-driver is an external unit to the LCD.

Table 2. ELECTRICAL CHARACTERISTICS

Parameter	Symbol	Values			Unit	Notes
		Min	Typ	Max		
MODULE :						
Power Supply Input Voltage	VCC	3.0	3.3	3.6	V _{DC}	
Power Supply Input Current	I _{CC}	100	(510)	600	mA	1
White		100	(430)	600		
Power Consumption	P _c	-	1.68	1.98	Watt	1
LED :						
LED current	I _{LED}	-	94.2	100	mA	2
LED voltage	V _{LED}	-	23.3	32.0	V	
LED power	P _{LED}	-	6.58	9.6	W	
LED chain			3			3
Life Time continuous		20,000	-	-	Hrs	4
Life Time intermittent		54,000	-	-	Cycles	5

Note)

- The specified current and power consumption are under the Vcc = 3.3V , 25 °C , fv = 60Hz condition whereas "Mosaic pattern" is displayed and fv is the frame frequency.
Typical current situation: 8 x 6 chess pattern; timing: CLK = 33 MHz

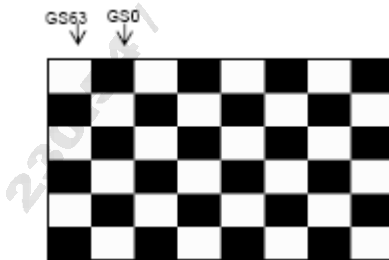

Max current situation: full white pattern(GS63) ; timing: CLK = 33 MHz



Power consumption condition

- Typ Pc: typ VCC x typ ICC(white pattern)
- Max Pc: typ VCC x max ICC(white pattern)

Product Specification

2. The permissible forward current of LED vary with environmental temperature.

Ambient Temperature vs. Allowable Forward Current

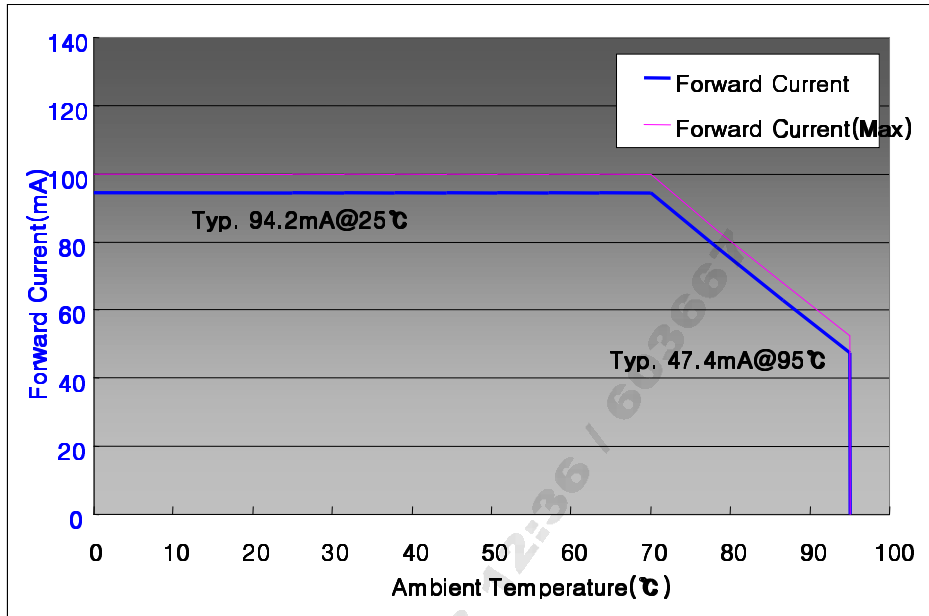

3. Principle sketch of LED chains

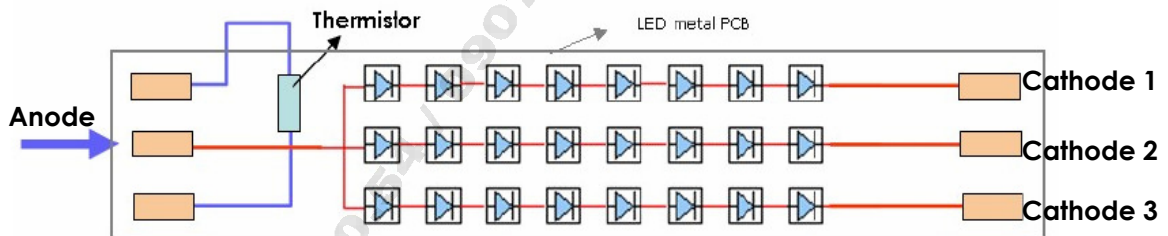

4. The life time is determined as the time at which brightness of LED is 50% compare to that of initial value at the typical LED current.

5. Intermittent cycle, at $V_{LED} = \text{typ}$, $I_{LED} = \text{typ}$.

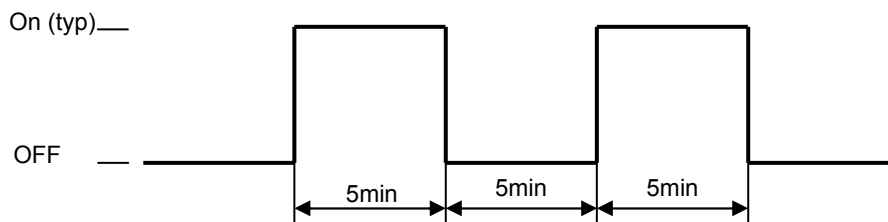

3-2. Interface Connections

This LCD employs two interface connections, a 40 pin connector is used for the module electronics interface and the other connector is used for the integral backlight system.

The electronics interface connector is a model 9828S-40A-GFC(IRISO), manufactured by IRISO.

The mating connector part number is 9827B-40A-GFC(IRISO) or equivalent.

Table 3. MODULE CONNECTOR PIN CONFIGURATION (CN1)

Pin No.	Symbol	Description	Pin No.	Symbol	Description
1	GND	Ground	21	GND	Ground
2	CLK	Clock	22	B0	Blue Data Signal 0(LSB)
3	GND	Ground	23	B1	Blue Data Signal 1
4	R0	Red Data Signal 0(LSB)	24	B2	Blue Data Signal 2
5	R1	Red Data Signal 1	25	B3	Blue Data Signal 3
6	R2	Red Data Signal 2	26	B4	Blue Data Signal 4
7	R3	Red Data Signal 3	27	B5	Blue Data Signal 5(MSB)
8	R4	Red Data Signal 4	28	GND	Ground
9	R5	Red Data Signal 5(MSB)	29	DE	Data Enable
10	GND	Ground	30	GND	Ground
11	Hsync	Horizontal Sync	31	HVR	Horizontally and Vertically Inverted
12	GND	Ground	32	GND	Ground
13	G0	Green Data Signal 0(LSB)	33	GND	Ground
14	G1	Green Data Signal 1	34	VCC	+3.3[V]
15	G2	Green Data Signal 2	35	VCC	+3.3[V]
16	G3	Green Data Signal 3	36	NC	No Connection
17	G4	Green Data Signal 4	37	NC	No Connection
18	G5	Green Data Signal 5(MSB)	38	GND	Ground
19	GND	Ground	39	NC	No Connection
20	Vsync	Vertical Sync	40	GND	Ground

[Note 1]

- Hsync = "Negative"
- Vsync = "Negative"

[Note 2]

- HVR="HIGH" → Regular Video
- HVR="LOW" → Horizontally and Vertically Inverted Video

Product Specification

The backlight interface connector is a model 9850S-10B-TR (IRISO), manufactured by IRISO or Compatible. The mating connector part number is 9859B-10B-TR (IRISO) or equivalent.

Table 4. BACKLIGHT CONNECTOR PIN CONFIGURATION (CN2)

Pin No.	Symbol	Description	Pin No.	Symbol	Description
1	NTC1	Temperature Sensor Pin1	6	BR_CA	Brightness Sensor Cathode
2	NTC2	Temperature Sensor Pin2	7	BL_AN	Backlight Anode of all chains
3	BL_CA_3	Backlight Chain 3 (Cathode)	8	BL_AN	Backlight Anode of all chains
4	BR_AN	Brightness Sensor Anode	9	BL_CA_2	Backlight Chain 2 (Cathode)
5	BL_AN	Backlight Anode of all chains	10	BL_CA_1	Backlight Chain 1 (Cathode)

3-3. Signal Timing Specifications

This is the signal timing required at the input of the User connector. All of the interface signal timing should be satisfied with the following specifications for its proper operation.

Table 5-1. TIMING TABLE

*** 50Hz Framerate ***

	Item	Symbol	Min.	Typ.	Max.	Unit	Remarks
DCLK	Frequency	f_{CLK}	31.50	33.00	34.54	MHz	
	Period	t_{CLK}	28.95	30.30	37.56	ns	
	High Level Width	t_{WCH}	6	-	-	ns	
	Low Level Width	t_{WCL}	6	-	-	ns	
DATA	Setup Time	t_{DS}	4	-	-	ns	
	Hold Time	t_{DH}	4	-	-	ns	
DE	Setup Time	t_{DES}	5	-	-	ns	
	Hold Time	t_{DEH}	5	-	-	ns	
Hsync	Period	t_{HP}	1024	1056	1088	t_{CLK}	
	Width	t_{WH}	10	128	-		
	Horizontal Valid	t_{HV}	-	800	-		
	Horizontal Back Porch	t_{HBP}	10	-	-		
	Horizontal Front Porch	t_{HFP}	10	-	-		
Vsync	Period	t_{VP}	616	625	635	t_{HP}	
	Width	t_{WV}	2	-	-		
	Vertical Valid	t_{VV}	-	480	-		
	Vertical Back Porch	t_{VBP}	6	-	-		
	Vertical Front Porch	t_{VFP}	2	-	-		

Product Specification

Table 5-2. TIMING TABLE

*** 60Hz Framerate ***

Item	Symbol	Min.	Typ.	Max.	Unit	Remarks	
DCLK	Frequency	f_{CLK}	31.95	33.26	34.60	MHz	
	Period	t_{CLK}	28.90	30.06	31.30	ns	
	High Level Width	t_{WCH}	6	-	-	ns	
	Low Level Width	t_{WCL}	6	-	-	ns	
DATA	Setup Time	t_{DS}	4	-	-	ns	
	Hold Time	t_{DH}	4	-	-	ns	
DE	Setup Time	t_{DES}	5	-	-	ns	
	Hold Time	t_{DEH}	5	-	-	ns	
Hsync	Period	t_{HP}	1024	1056	1088	t_{CLK}	
	Width	t_{WH}	10	128	-		
	Horizontal Valid	t_{HV}	-	800	-		
	Horizontal Back Porch	t_{HBP}	10	-	-		
	Horizontal Front Porch	t_{HFP}	10	-	-		
Vsync	Period	t_{VP}	520	525	530	t_{HP}	
	Width	t_{WV}	2	-	-		
	Vertical Valid	t_{VV}	-	480	-		
	Vertical Back Porch	t_{VBP}	6	-	-		
	Vertical Front Porch	t_{VFP}	2	-	-		

Note)

1. Low active: see 3-4 "Signal Timing Waveforms"
2. Max Value has no meaning. Thereform, they are not defined.
3. RGB data, Hsync, Vsync, DE signals change logic level in synchronization whit DCLK(rising edge). Values are valid with the falling edge fo DCLK.
4. In case of no valid data is available(missing like DCLK, DE) LCD display black screen.

3-4. Signal Timing Waveforms

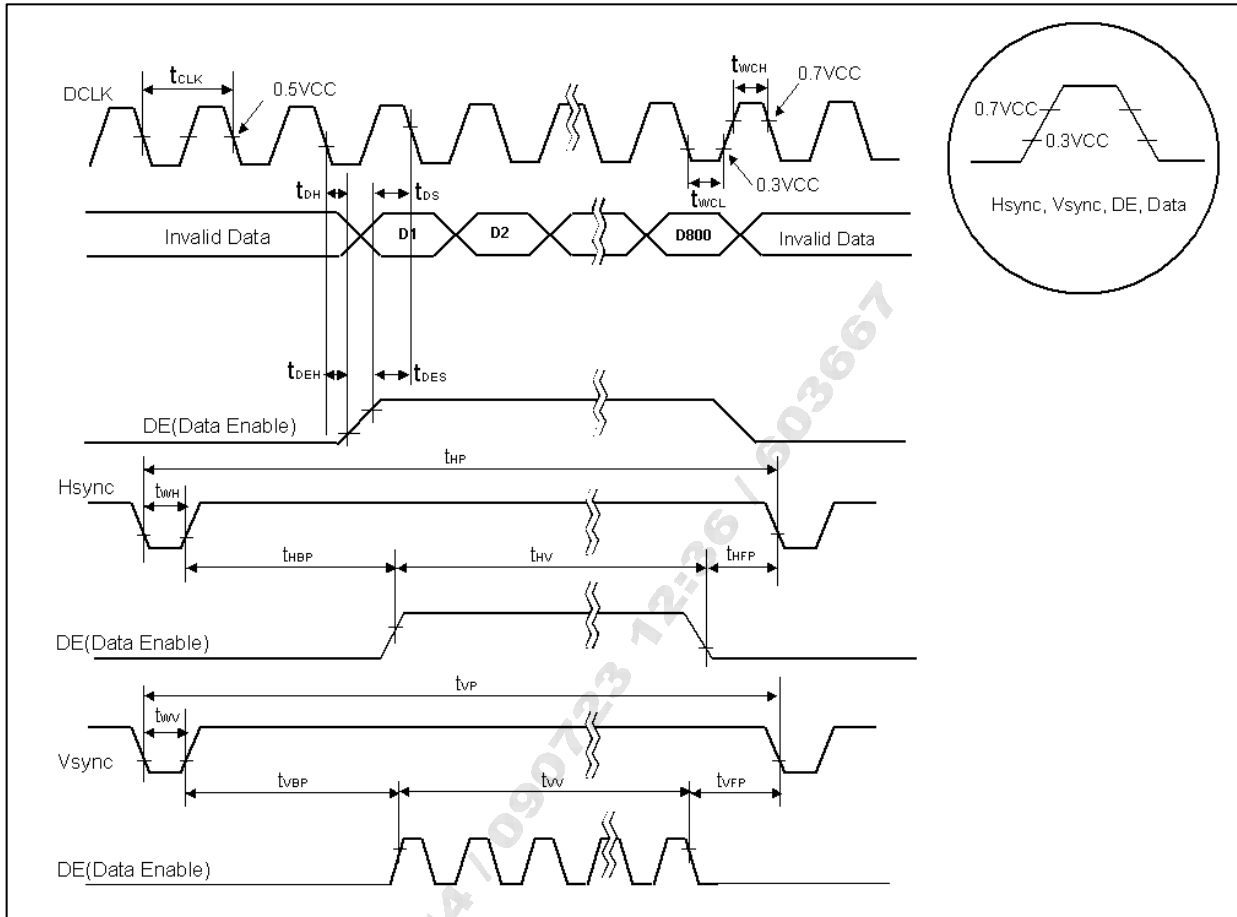

3-5. Color Input Data Reference

The brightness of each primary color (red, green and blue) is based on the 6-bit gray scale data input for the color ; the higher the binary input, the brighter the color. The table below provides a reference for color versus data input.

Table 6. COLOR DATA REFERENCE

Color		Input Color Data																					
		RED						GREEN						BLUE									
		MSB						LSB		MSB						LSB		MSB					
		R5	R4	R3	R2	R1	R0	G5	G4	G3	G2	G1	G0	B5	B4	B3	B2	B1	B0				
Basic Color	Black	0	0	0	0	0	0	0	0	0	0	0	0	0	0	0	0	0	0				
	Red	1	1	1	1	1	1	0	0	0	0	0	0	0	0	0	0	0	0				
	Green	0	0	0	0	0	0	1	1	1	1	1	1	0	0	0	0	0	0				
	Blue	0	0	0	0	0	0	0	0	0	0	0	0	1	1	1	1	1	1				
	Cyan	0	0	0	0	0	0	1	1	1	1	1	1	1	1	1	1	1	1				
	Magenta	1	1	1	1	1	1	0	0	0	0	0	0	1	1	1	1	1	1				
	Yellow	1	1	1	1	1	1	1	1	1	1	1	1	0	0	0	0	0	0				
	White	1	1	1	1	1	1	1	1	1	1	1	1	1	1	1	1	1	1				
RED	RED (00)	0	0	0	0	0	0	0	0	0	0	0	0	0	0	0	0	0	0				
	RED (01)	0	0	0	0	0	1	0	0	0	0	0	0	0	0	0	0	0	0				
	...																						
	RED (62)	1	1	1	1	1	0	0	0	0	0	0	0	0	0	0	0	0	0				
	RED (63)	1	1	1	1	1	1	0	0	0	0	0	0	0	0	0	0	0	0				
GREEN	GREEN (00)	0	0	0	0	0	0	0	0	0	0	0	0	0	0	0	0	0	0				
	GREEN (01)	0	0	0	0	0	0	0	0	0	0	0	1	0	0	0	0	0	0				
	...																						
	GREEN (62)	0	0	0	0	0	0	1	1	1	1	1	0	0	0	0	0	0	0				
	GREEN (63)	0	0	0	0	0	0	1	1	1	1	1	1	0	0	0	0	0	0				
BLUE	BLUE (00)	0	0	0	0	0	0	0	0	0	0	0	0	0	0	0	0	0	0				
	BLUE (01)	0	0	0	0	0	0	0	0	0	0	0	0	0	0	0	0	0	1				
	...																						
	BLUE (62)	0	0	0	0	0	0	0	0	0	0	0	0	1	1	1	1	1	0				
	BLUE (63)	0	0	0	0	0	0	0	0	0	0	0	0	1	1	1	1	1	1				

3-6. Power Sequence

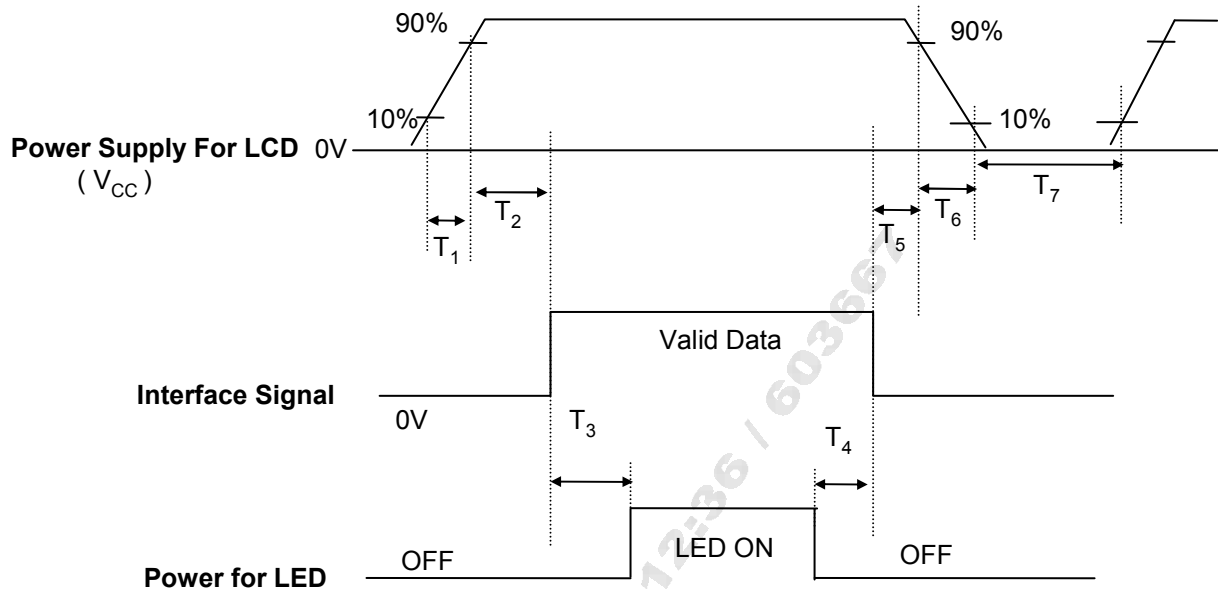
Table 7. POWER SEQUENCE TABLE

Parameter	Value			Units
	Min.	Typ.	Max.	
T ₁	0.5	-	10	(ms)
T ₂	50	-	-	(ms)
T ₃	100	-	-	(ms)
T ₄	200	-	-	(ms)
T ₅	0	-	-	(ms)
T ₆	0	-	10	(ms)
T ₇	400	-	-	(ms)

Note)

1. Please avoid floating state of interface signal at invalid period.
2. When the interface signal is invalid, be sure to pull down the power supply for LCD VCC to 0V.
3. LED power must be turn on after power supply for LCD and interface signal are valid.

Product Specification

3-7. Thermistor

*NCP18XW223E03RB made by Murata Manufacturing Co., Ltd

- Resistance : 22k ohm \pm 3%
- B-Constant : 3950K \pm 3%

Temp. (°C)	R _{TYP.} (kohm)	Temp. (°C)	R _{TYP.} (kohm)
-30	396.07	+30	17.71
-25	291.02	+35	14.34
-20	216.01	+40	11.69
-15	161.98	+45	9.58
-10	122.64	+50	7.89
-5	93.70	+55	6.54
0	72.19	+60	5.45
+5	56.09	+65	4.56
+10	43.91	+70	3.83
+15	34.63	+75	3.24
+20	27.51	+80	2.75
+25	22.00	+85	2.34

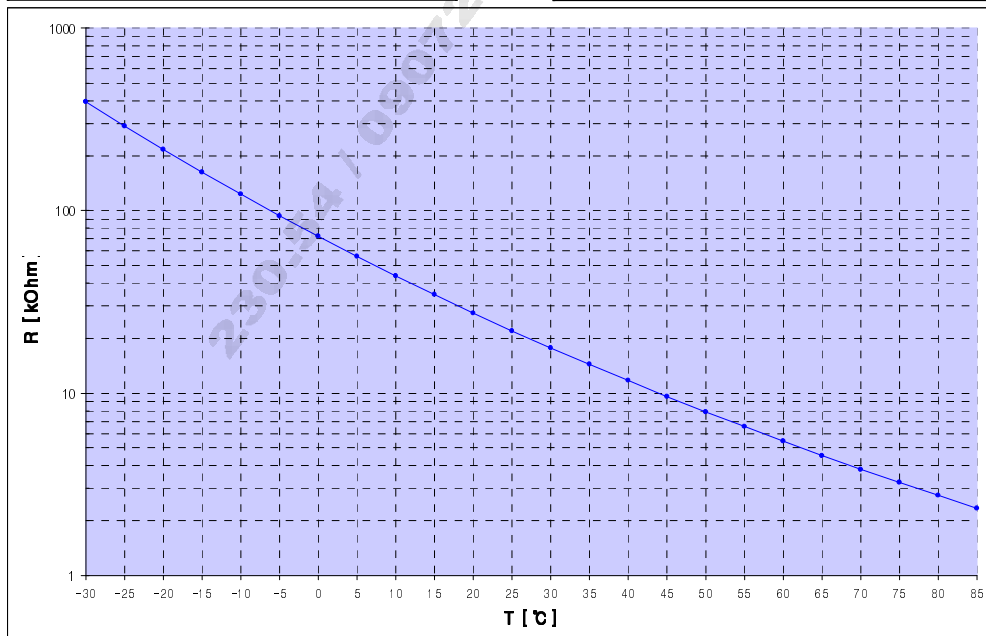
3-8. Brightness Sensor

*SFH5711 made by OSRAM

A brightness sensor is built in control PCB to measure the brightness of the backlight. Ambient light don't influence the output signal of the brightness sensor.

Product Specification

4. Optical Specification

Optical characteristics are determined after the unit has been 'ON' and stable for approximately 30 minutes in a dark environment at 25°C. The values specified are at an approximate distance 50cm from the LCD surface at a viewing angle of Φ and Θ equal to 0°.

FIG. 1 presents additional information concerning the measurement equipment and method.

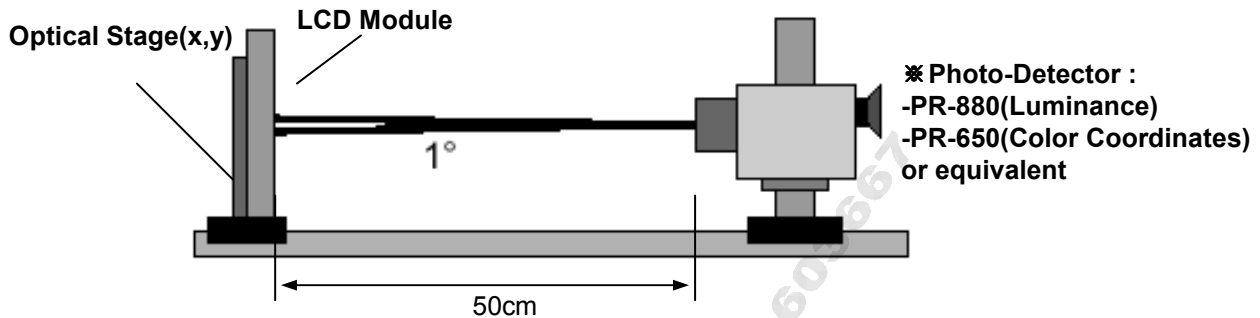
FIG. 1 Optical Characteristic Measurement Equipment and Method

Table 9. OPTICAL CHARACTERISTICS

[With LCF & Enhanced Single-Peak]

 Ta=25°C, VCC=3.3V, fv=60Hz, f_{CLK}= 33.26MHz, I_{LED} = 94.2mA/chain

Parameter	Symbol	Values			Units	Notes
		Min	Typ	Max		
Contrast Ratio	CR	630	(900)	-		1
Surface Luminance, white ($\Theta=0^\circ$)	L _{WH}	470	-	-	cd/m ²	2
Surface Luminance, white($\Phi=180^\circ \Theta=30^\circ$)	L _{WH LEFT}	410	-	-	cd/m ²	
Surface Luminance, white($\Phi=0^\circ \Theta=30^\circ$)	L _{WH RIGHT}	310	-	-	cd/m ²	
Luminance Variation	δ_{WHITE}	80	85	-	%	3
Response Time						4
Rise Time	T _R	-	15	20	ms	
Decay Time	T _D	-	14	18	ms	
Color Coordinates						2
RED	RX	0.605	0.635	0.665		
	RY	0.319	0.349	0.379		
GREEN	GX	0.299	0.329	0.359		
	GY	0.584	0.614	0.644		
BLUE	BX	0.118	0.148	0.178		
	BY	0.066	0.096	0.126		
WHITE	WX	0.282	0.312	0.342		
	WY	0.306	0.336	0.366		
Viewing Angle						5
x axis, right($\Phi=0^\circ$)	Θ_r	65	70	-	degree	
x axis, left ($\Phi=180^\circ$)	Θ_l	65	70	-	degree	
y axis, up ($\Phi=90^\circ$)	Θ_u	25	30	-	degree	
y axis, down ($\Phi=270^\circ$)	Θ_d	30	40	-	degree	
Gray Scale		-	2.2	-		6

Product Specification

Note)

1. Contrast Ratio(CR) is defined mathematically as

$$\text{Contrast Ratio} = \frac{\text{Surface Luminance with all white pixels}}{\text{Surface Luminance with all black pixels}}$$

2. Surface luminance is measured at the center point(L₁) of the LCD with all pixels displaying white at the distance of 50cm by PR-880. Color Coordinates are measured at the center point(L₁) of the LCD with all pixels displaying red, green, blue and white at the distance of 50cm by PR-650. For more information, refer to the FIG 1 and FIG 2.

3. Luminance % uniformity is measured for 9 point For more information see FIG 2.

$$\delta \text{ WHITE} = \{ \text{Minimum}(L_1, L_2, \dots, L_9) \div \text{Maximum}(L_1, L_2, \dots, L_9) \} * 100(\%)$$

4. Response time is the time required for the display to transition from white to black (Rise Time, Tr_R) and from black to white(Decay Time, Tr_D). For additional information see FIG 3.

5. Viewing angle is the angle at which the contrast ratio is greater than 10. The angles are determined for the horizontal or x axis and the vertical or y axis with respect to the z axis which is normal to the LCD surface. For more information see FIG 4.

6. Gray scale specification

Gray Level	Luminance [%] (Typ)
L0	0.13
L7	0.68
L15	3.43
L23	9.04
L31	18.07
L39	30.75
L47	47.88
L55	72.83
L63	100.00

Product Specification

FIG. 4 Viewing angle

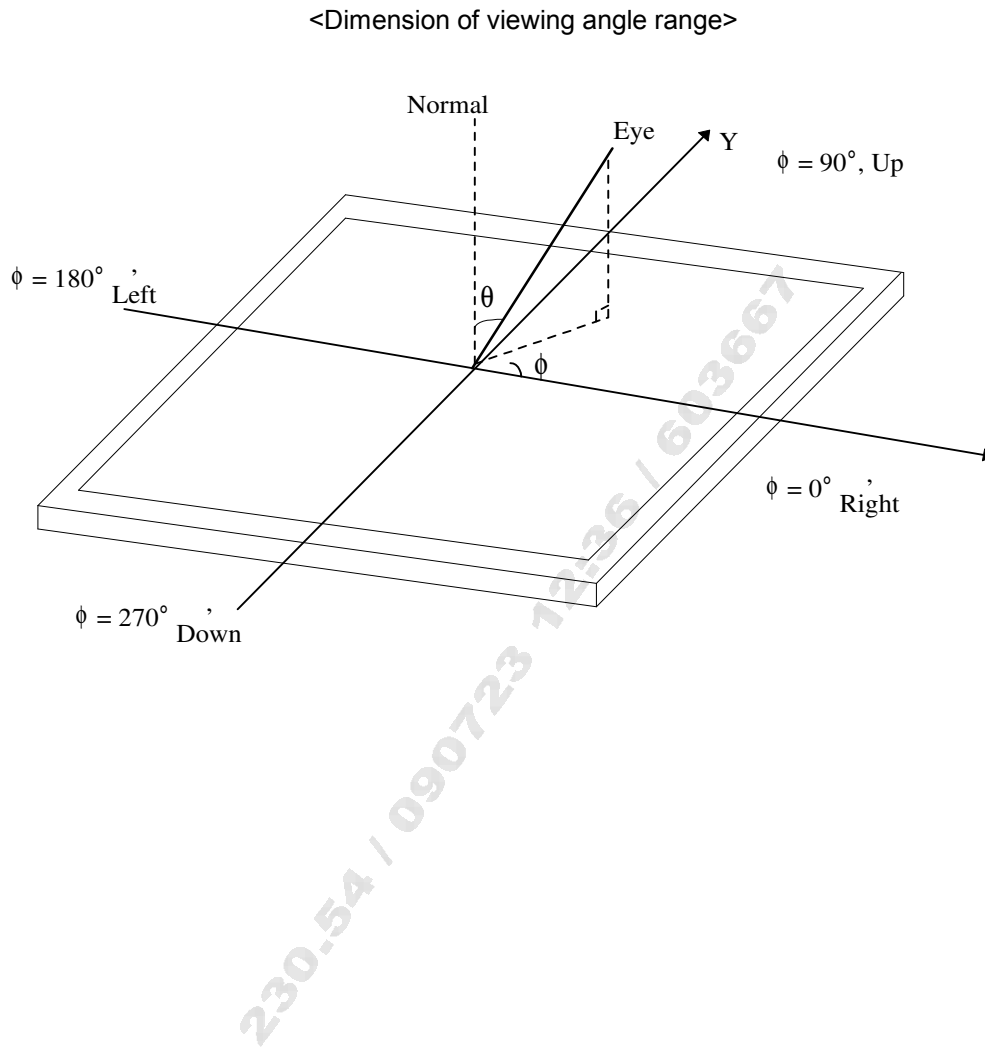

5. Mechanical Characteristics

The contents provide general mechanical characteristics for the model LB070WV1. In addition the figures in the next page are detailed mechanical drawing of the LCD.

Outline Dimension	Horizontal	170.0 mm (± 0.3)mm.
	Vertical	109.6 mm (± 0.3)mm
	Depth	15.3 mm (± 0.3)mm
Bezel Area	Horizontal	155.8 mm (± 0.3)mm
	Vertical	94.8 mm (± 0.3)mm
Active Display Area	Horizontal	152.40 mm (± 0.3)mm
	Vertical	91.44 mm (± 0.3)mm
Weight	325g(Typ.) / 375g (Max.)	
Surface Treatment	Anti-glare/Anti-Reflection treatment of the front polarizer	

Product Specification

<FRONT VIEW>

Note) Unit:[mm], General tolerance: ± 0.3 mm

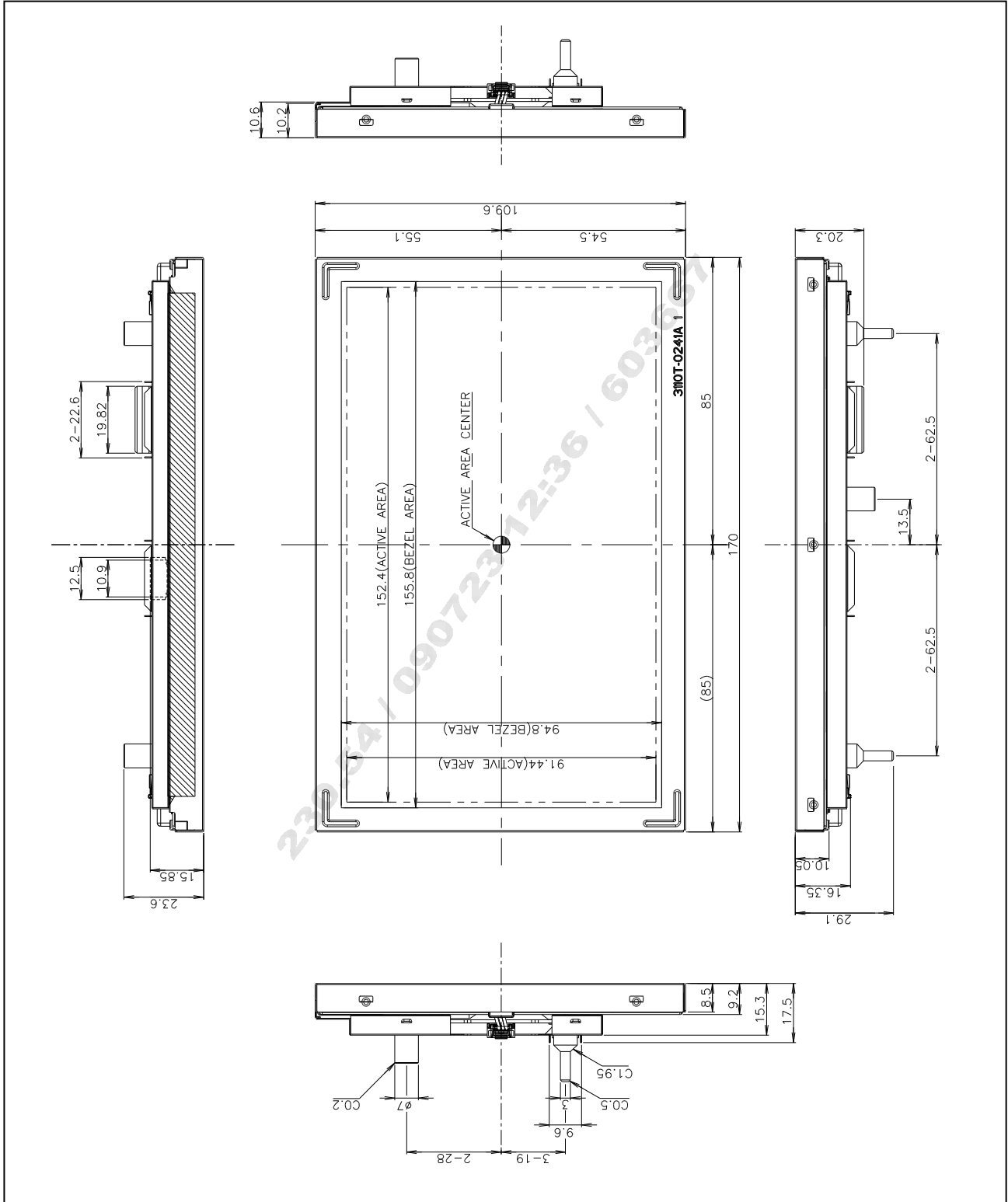

6. Reliability

Environment test condition

No.	Test Item	Conditions
1	High Temperature Storage Test	Ta=+105℃ 500h
2	Low Temperature Storage Test	Ta=-40℃ 100h
3	High Temperature Operation Test	Tp=+95℃ 200h
4	High Temperature and High Humidity Storage Test	Tp=+65℃ 93%RH 500h
5	Vibration test (non-operating)	10 - 30 Hz : ± 0.75mm 30 - 500 Hz : 3G 1 Oct./min 3x (16h sinusoidal and 8h random) in X, Y and Z direction)
6	Shock test (non-operating)	3 shocks in each direction Peak acceleration: 981 m/s ² Duration of nominal shock: 6ms Waveform: saw-tooth with slow rise(2.94 m/s) or half-sine
7	Thermal Shock Test (non-operating)	Ta=-40℃ ~ +95℃ 2h duration / 10 cycles
8	Electrostatic Discharge	Probe Settings: ± 2kV (330Ω/150pF) Sample quantity: 3 displays 3 contact discharges on all critical positions of the display (such as all connector pins, display viewing area, backside of driver, contact ledge).

※ Ta= Ambient Temperature, Tp= Panel Temperature

{ Result Evaluation Criteria }

There should be no change which might affect the practical display function when the display quality test is conducted under normal operating condition.

7. International Standards

7-1. Safety

- a) UL 60950-1:2003, First Edition, Underwriters Laboratories, Inc., Standard for Safety of Information Technology Equipment.
- b) CAN/CSA C22.2, No. 60950-1-03 1st Ed. April 1, 2003, Canadian Standards Association, Standard for Safety of Information Technology Equipment.
- c) EN 60950-1:2001, First Edition, European Committee for Electrotechnical Standardization(CENELEC) European Standard for Safety of Information Technology Equipment.

7-2. EMC

- a) ANSI C63.4 "Methods of Measurement of Radio-Noise Emissions from Low-Voltage Electrical and Electrical Equipment in the Range of 9kHz to 40GHz." American National Standards Institute(ANSI), 1992
- b) C.I.S.P.R. "Limits and Methods of Measurement of Radio Interface Characteristics of Information Technology Equipment." International Special Committee on Radio Interference.
- c) EN 55022 "Limits and Methods of Measurement of Radio Interface Characteristics of Information Technology Equipment." European Committee for Electrotechnical Standardization.(CENELEC), 1998 (Including A1: 2000)

Product Specification

8. Packing

8-1. Designation of Lot Mark

a) Lot Mark

A	B	C	D	E	F	G	H	I	J	K	L	M
---	---	---	---	---	---	---	---	---	---	---	---	---

A,B,C : SIZE(INCH)
E : MONTH

D : YEAR
F ~ M : SERIAL NO.

Note

1. YEAR

Year	2001	2002	2003	2004	2005	2006	2007	2008	2009	2010
	2011	2012	2013	2014	2015	2016	2017	2018	2019	2020
Mark	1	2	3	4	5	6	7	8	9	0

2. MONTH

Month	Jan	Feb	Mar	Apr	May	Jun	Jul	Aug	Sep	Oct	Nov	Dec
Mark	1	2	3	4	5	6	7	8	9	A	B	C

b) Location of Lot Mark

Serial No. is printed on the label. The label is attached to the backside of the LCD module.
This is subject to change without prior notice.

8-2. Packing Form

a) Package quantity in one box : 18 pcs

b) Box Size : 572 mm × 372 mm × 156 mm

9. PRECAUTIONS

Please pay attention to the followings when you use this TFT LCD module.

9-1. MOUNTING PRECAUTIONS

- (1) You must mount a module using holes arranged in four corners or four sides.
- (2) You should consider the mounting structure so that uneven force (ex. Twisted stress) is not applied to the module. And the case on which a module is mounted should have sufficient strength so that external force is not transmitted directly to the module.
- (3) Please attach the surface transparent protective plate to the surface in order to protect the polarizer. Transparent protective plate should have sufficient strength in order to resist external force.
- (4) You should adopt radiation structure to satisfy the temperature specification.
- (5) Acetic acid type and chlorine type materials for the cover case are not desirable because the former generates corrosive gas of attacking the polarizer at high temperature and the latter causes circuit break by electro-chemical reaction.
- (6) Do not touch, push or rub the exposed polarizers with glass, tweezers or anything harder than HB pencil lead. And please do not rub with dust clothes with chemical treatment. Do not touch the surface of polarizer for bare hand or greasy cloth. (Some cosmetics are detrimental to the polarizer.)
- (7) When the surface becomes dusty, please wipe gently with absorbent cotton or other soft materials like chamois soaks with petroleum benzene. Normal-hexane is recommended for cleaning the adhesives used to attach front / rear polarizers. Do not use acetone, toluene and alcohol because they cause chemical damage to the polarizer.
- (8) Wipe off saliva or water drops as soon as possible. Their long time contact with polarizer causes deformations and color fading.
- (9) Do not open the case because inside circuits do not have sufficient strength.

9-2. OPERATING PRECAUTIONS

- (1) The spike noise causes the mis-operation of circuits. It should be lower than following voltage :
 $V = \pm 200\text{mV}$ (Over and under shoot voltage)
- (2) Response time depends on the temperature. (In lower temperature, it becomes longer.)
- (3) Brightness depends on the temperature. (In lower temperature, it becomes lower.)
And in lower temperature, response time (required time that brightness is stable after turned on) becomes longer.
- (4) Be careful for condensation at sudden temperature change. Condensation makes damage to polarizer or electrical contacted parts. And after fading condensation, smear or spot will occur.
- (5) When fixed patterns are displayed for a long time, remnant image is likely to occur.
- (6) Module has high frequency circuits. Sufficient suppression to the electromagnetic interference shall be done by system manufacturers. Grounding and shielding methods may be important to minimize the interference.

9-3. ELECTROSTATIC DISCHARGE CONTROL

Since a module is composed of electronic circuits, it is not strong to electrostatic discharge. Make certain that treatment persons are connected to ground through wrist band etc. And don't touch interface pin directly.

9-4. PRECAUTIONS FOR STRONG LIGHT EXPOSURE

Strong light exposure causes degradation of polarizer and color filter.

9-5. STORAGE

When storing modules as spares for a long time, the following precautions are necessary.

- (1) Store them in a dark place. Do not expose the module to sunlight or fluorescent light. Keep the temperature between 5°C and 35°C at normal humidity.
- (2) The polarizer surface should not come in contact with any other object.
It is recommended that they be stored in the container in which they were shipped.

9-6. HANDLING PRECAUTIONS FOR PROTECTION FILM

- (1) When the protection film is peeled off, static electricity is generated between the film and polarizer.
This should be peeled off slowly and carefully by people who are electrically grounded and with well ion-blown equipment or in such a condition, etc.
- (2) The protection film is attached to the polarizer with a small amount of glue. If some stress is applied to rub the protection film against the polarizer during the time you peel off the film, the glue is apt to remain on the polarizer.
Please carefully peel off the protection film without rubbing it against the polarizer.
- (3) When the module with protection film attached is stored for a long time, sometimes there remains a very small amount of glue still on the polarizer after the protection film is peeled off.
- (4) You can remove the glue easily. When the glue remains on the polarizer surface or its vestige is recognized, please wipe them off with absorbent cotton waste or other soft material like chamois soaked with normal-hexane.