

Product Specification

## SPECIFICATION FOR APPROVAL

- ( ) Preliminary Specification
- ( ● ) Final Specification

Title	7.0" WVGA (800 x 480 x RGB) TFT LCD
-------	-------------------------------------

BUYER	
MODEL	

SUPPLIER	LG.Display Co., Ltd.
*MODEL	LB070WV6
Suffix	TD08

SIGNATURE	DATE
/	_____
/	_____
/	_____

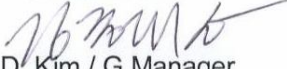
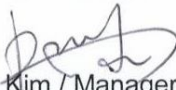
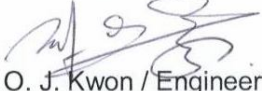
SIGNATURE	DATE
 J. D. Kim / G. Manager	2010. 03. 25
<b>REVIEWED BY</b>  J. Y. Kim / Manager	2010. 03. 25
<b>PREPARED BY</b>  O. J. Kwon / Engineer	2010. 03. 25

Please return 1 copy for your confirmation with your signature and comments.

**Products Engineering Dept.  
LG Display Co., Ltd**

## Product Specification

## Contents

No	ITEM	Page
	COVER	1
	CONTENTS	2
	RECORD OF REVISIONS	3
1	GENERAL DESCRIPTION	4
2	ABSOLUTE MAXIMUM RATINGS	5
3	ELECTRICAL SPECIFICATIONS	6
3-1	ELECTRICAL CHARACTERISTICS	6
3-2	INTERFACE CONNECTIONS	7
3-3	SIGNAL TIMING SPECIFICATIONS	8
3-4	SIGNAL TIMING WAVEFORMS	9
3-5	COLOR INPUT DATA REFERENCE	10
3-6	POWER SEQUENCE	11
4	OPTICAL SPECIFICATIONS	12
5	MECHANICAL CHARACTERISTICS	16
6	RELIABILITY	19
7	INTERNATIONAL STANDARDS	20
7-1	SAFETY	20
7-2	EMC	20
7-3	ENVIRONMENT	20
8	PACKING	21
8-1	DESIGNATION OF LOT MARK	21
8-2	PACKING FORM	21
9	PRECAUTIONS	22



Product Specification

### 1. General Description

The LB070WV6 is a Color Active Matrix Liquid Crystal Display with an integral Light Emitting Diode(LED) backlight system. The matrix employs a-Si Thin Film Transistor as the active element. It is a transmissive type display operating in the normally white mode. This TFT-LCD has 7.0 inches diagonally measured active display area with WVGA resolution(800 horizontal by 480 vertical pixel array). Each pixel is divided into Red, Green and Blue sub-pixels or dots which are arranged in horizontal stripes. Gray scale or the brightness of the sub-pixel color is determined with a 8-bit gray scale signal for each dot, thus, presenting a palette of more than 16,772,216 colors.

The LB070WV6 has been designed to apply the interface method that enables low power, high speed, low EMI.

The LB070WV6 is intended to support applications where thin thickness, low power are critical factors and graphic displays are important. In combination with the horizontal arrangement of the sub-pixels, the LB070WV6 characteristics provide an excellent flat display.

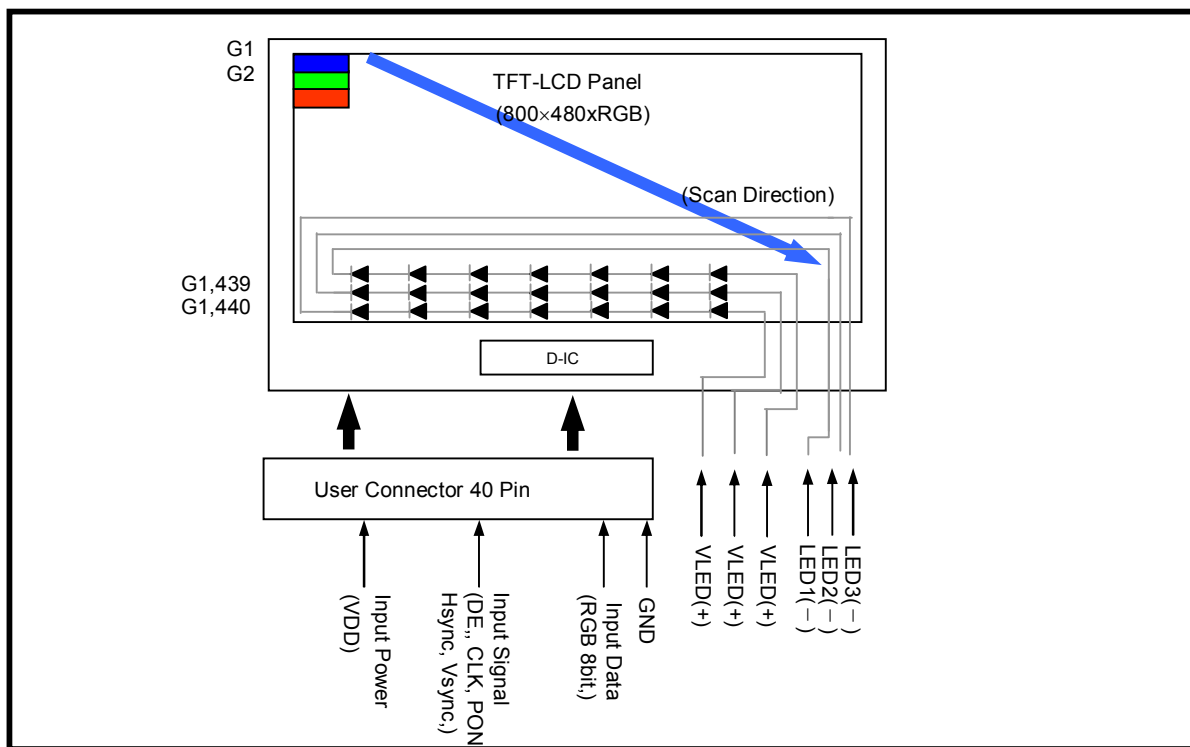

### General Features

Active Screen Size	7.0 inches diagonal
Outline Dimension	165x104.6x3.3mm
Pixel Pitch	0.1893 mm × 0.1887 mm
Pixel Format	800 horiz. by 480 vert. Pixels RGB strip arrangement
Color Depth	8-bit, 16,772,216 colors
Luminance, White	350 cd/m <sup>2</sup> (Typ.)
Power Consumption	0.29W(logic), 1.34W(LED)
Weight	107.7g(Typ)
Display Operating Mode	Transmissive mode, normally white
Surface Treatment	Anti-glare treatment of the front polarizer
Viewing Direction	6 o'clock

Product Specification

**2. Absolute Maximum Ratings**

The following are maximum values which, if exceeded, may cause faulty operation or damage to the unit.

**Table 1. ABSOLUTE MAXIMUM RATINGS**

Parameter	Symbol	Values		Units	Notes
		Min	Max		
Power Input Voltage	VCC	0.0	3.6	Vdc	at 25 ± 5°C
Storage Temperature	T <sub>ST</sub>	-30	80	°C	1
Operating Temperature	T <sub>OP</sub>	-20	70	°C	1,2

Notes :

1. Maximum wet-bulb temperature is 58°C. Condensation of dew must be avoided, because it may cause electrical current leakage, and deterioration of performance and quality.
2. The operating temperature means that LCD Module guarantees operation of the circuit.  
All the contents of Electro-optical specifications are guaranteed under the room temperature condition.

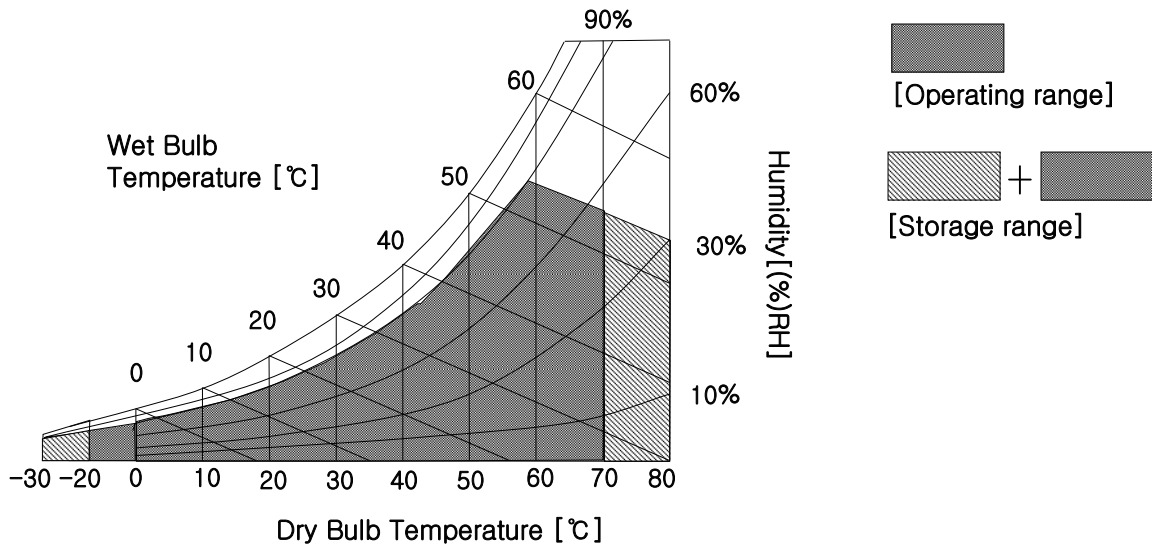

Product Specification

### 3. Electrical Specifications

#### 3-1. Electrical Characteristics

The LB070WV6 requires two power inputs. One is employed to power the LCD electronics and to drive the TFT array and liquid crystal. The second input which powers the LED, is typically generated by an LED Driver. The LCD don't include LED Driver.

**Table 2. ELECTRICAL CHARACTERISTICS**

Parameter	Symbol	Values			Unit	Notes
		Min	Typ	Max		
LCD :						
Power Supply Input Voltage	VCC	3.0	3.3	3.6	V <sub>DC</sub>	
Input High-Level Voltage	V <sub>IH</sub>	0.8XVCC	-	VCC	V <sub>DC</sub>	
Input Low-Level Voltage	V <sub>IL</sub>	0	-	0.2XVCC	V <sub>DC</sub>	
Power Supply Input Current	I <sub>CC</sub>	-	86.7	99.7	mA	1
Power Consumption	P <sub>c</sub>	-	0.29	0.36	Watt	1

Note)

- The specified current and power consumption are under the Vcc = 3.3V , 25°C, fv = 60Hz condition whereas “Full Black Pattern” is displayed and fv is the frame frequency.

**Table 3. Backlight Unit**

(*T<sub>a</sub>* = 25°C)

PARAMETER	SYMBOL	MIN.	TYP.	MAX.	UNIT	REMARK
LED forward Current	I <sub>f</sub>	-	20	30	mA	1, Per chain
LED forward Voltage	V <sub>f</sub>	-	22.40	24.50	V	1, Per chain
Power Consumption	P <sub>BL</sub>	-	1.34	1.47	W	The sum of 3 chain at 20mA

Note)

- The permissible forward current of LED vary with environmental temperature.

Forward Current Derating Curve

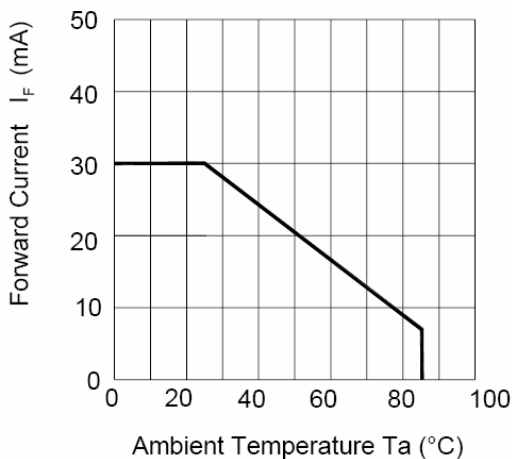

### 3-2. Interface Connections

**Table 4. MODULE CONNECTOR PIN CONFIGURATION (CN1)**

Pin No.	Symbol	Description	Pin No.	Symbol	Description
1	GND	Ground	21	B0	Blue Data 0 [LSB]
2	GND	Ground	22	B1	Blue Data 1
3	VCC	Power Line For Logic	23	B2	Blue Data 2
4	VCC	Power Line For Logic	24	B3	Blue Data 3
5	R0	Red Data 0 [LSB]	25	B4	Blue Data 4
6	R1	Red Data 1	26	B5	Blue Data 5
7	R2	Red Data 2	27	B6	Blue Data 6
8	R3	Red Data 3	28	B7	Blue Data 7 [MSB]
9	R4	Red Data 4	29	GND	Ground
10	R5	Red Data 5	30	DCLK	Dot clock signal
11	R6	Red Data 6	31	PON	Display mode control
12	R7	Red Data 7 [MSB]	32	NC	No Connection
13	G0	Green Data 0 [LSB]	33	NC	No Connection
14	G1	Green Data 1	34	DE	Data enable
15	G2	Green Data 2	35	NC	No Connection
16	G3	Green Data 3	36	NC	No Connection
17	G4	Green Data 4	37	GND	Ground
18	G5	Green Data 5	38	GND	Ground
19	G6	Green Data 6	39	NC	No Connection
20	G7	Green Data 7 [MSB]	40	NC	No Connection

(Connector Type : 40Pin 0.5mm pitch.

Matching Connector : Hirose FH12 Series)

**Table 5. LED CONNECTOR PIN CONFIGURATION (CN2)**

Pin No.	Symbol	Description
1	LED1(-)	Current Sink For LED1
2	VLED(+)	Power Line For LED
3	LED2(-)	Current Sink For LED2
4	VLED(+)	Power Line For LED
5	LED3(-)	Current Sink For LED3
6	VLED(+)	Power Line For LED

(Connector Type : 6Pin 0.5mm pitch.

Matching Connector : Hirose TF12S-6S-0.5SH)

## Product Specification

### 3-3. Signal Timing Specifications

This is the signal timing required at the input of the User connector. All of the interface signal timing should be satisfied with the following specifications for its proper operation.

**Table 6. TIMING TABLE**

\*\*\* 60Hz Framerate \*\*\*

Item	Symbol	Min.	Typ.	Max.	Unit	Remarks	
Frame frequency		55	60	65	Hz	Note 1	
DCLK	Frequency	fCLK	27.1	31.0	35.1	MHz	
	Period	tDCYC	28.49	32.26	36.90	ns	
	DOTCLK rise/fall time	tR, tF	-	-	2	ns	
	High Level Width	tDCHW	9	-	-	ns	
	Low Level Width	tDCLW	9	-	-	ns	
DATA	Setup Time	tENS	5	-	-	ns	
	Hold Time	tENH	5	-	-	ns	
DE	Setup Time	tPDS	5	-	-	ns	
	Hold Time	tPDH	5	-	-	ns	
	Horizontal Active Period	tHA	-	800	-	CLK	
	Horizontal Blank Period	tHB	175	217	256	CLK	
	Horizontal Period	tH	975	1017	1056	CLK	Note 2
	Vertical Active Period	tVA	-	480	-	CLK	
	Vertical Blank Period	tVB	25	28	31	CLK	
	Vertical Period	tV	505	508	511	CLK	

Note)

1. Typical frequency is 60Hz.  
The lower frequency goes, the more flickering happens.
2. DOTCLK should be n times of 3 in Horizontal period(tH).



### 3-4. Signal Timing Waveforms

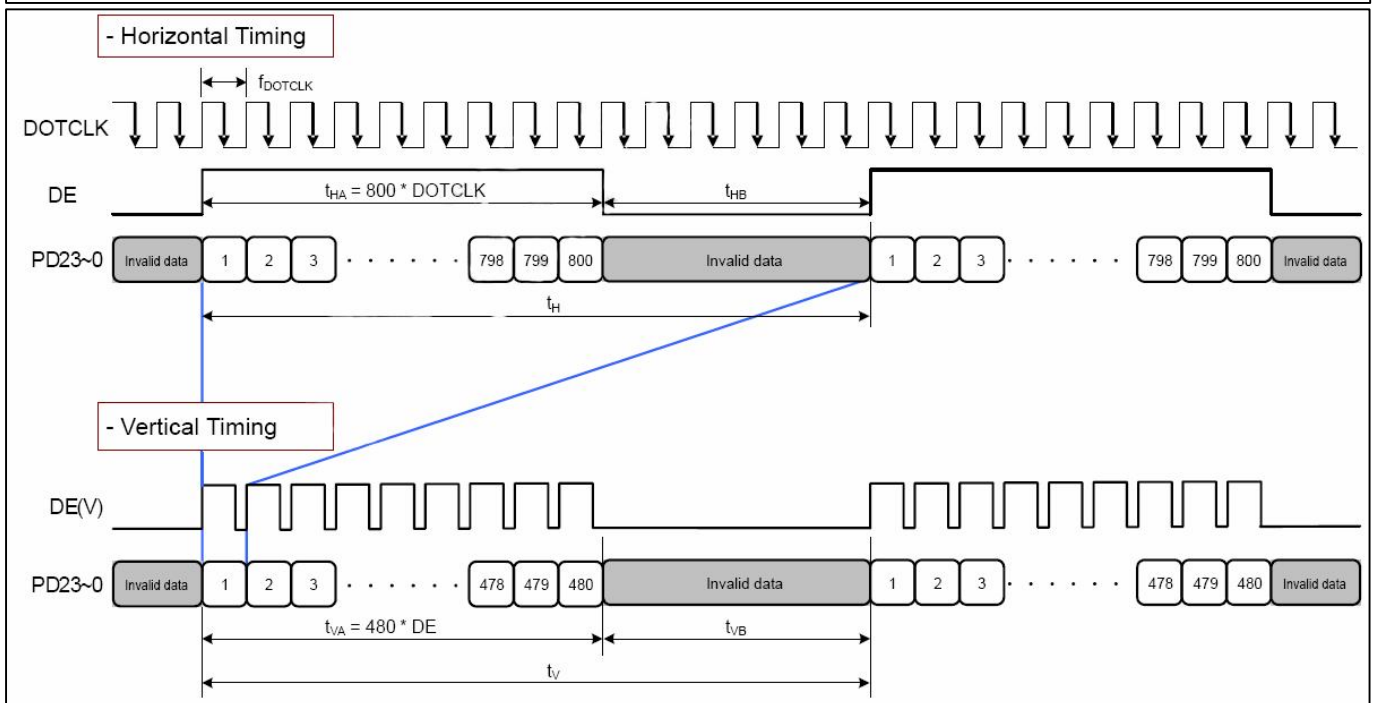
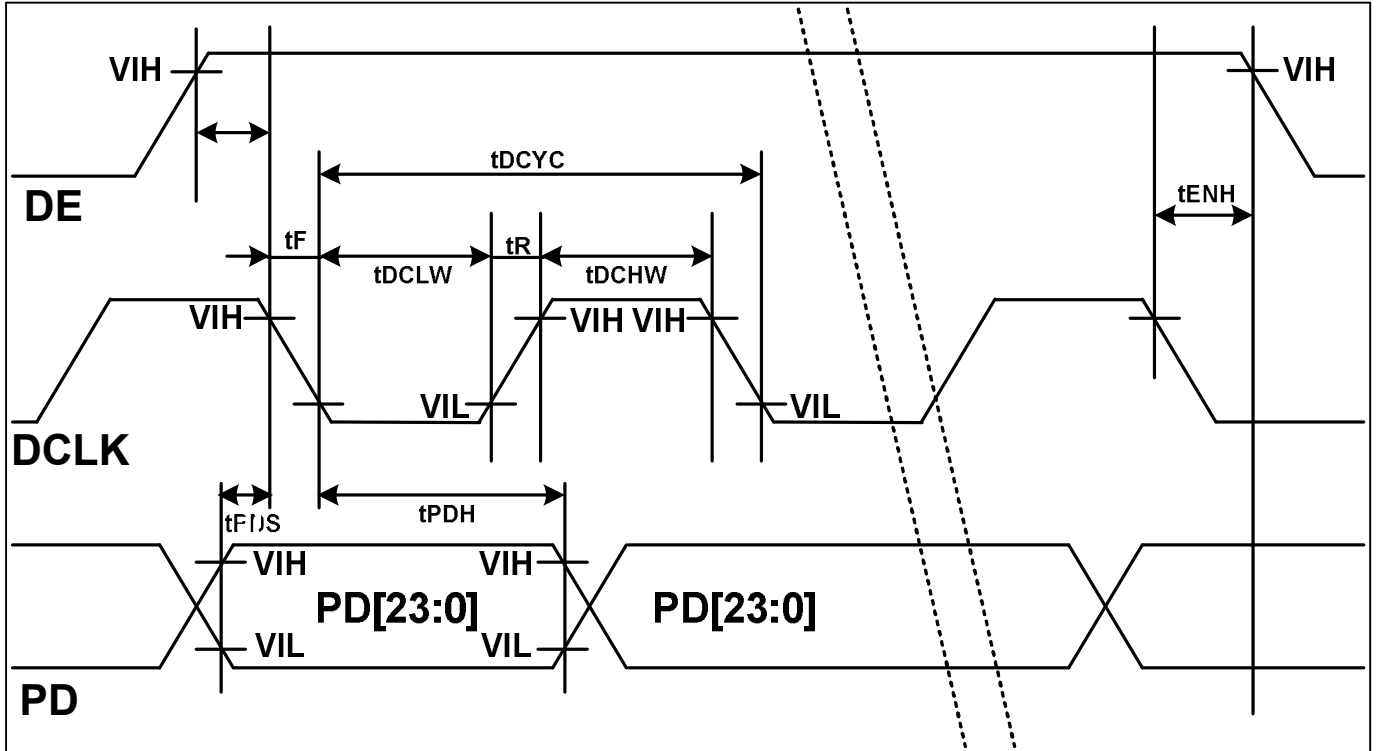

## Product Specification

### 3-5. Color Input Data Reference

The brightness of each primary color (red, green and blue) is based on the 6-bit gray scale data input for the color ; the higher the binary input, the brighter the color. The table below provides a reference for color versus data input.

**Table 7. COLOR DATA REFERENCE**

Colors & Gray Scale	Gray Scale Levels	Data Signal																											
		RED							GREEN							BLUE													
		R0	R1	R2	R3	R4	R5	R6	R7	G0	G1	G2	G3	G4	G5	G6	G7	B0	B1	B2	B3	B4	B5	B6	B7				
Black	---	0	0	0	0	0	0	0	0	0	0	0	0	0	0	0	0	0	0	0	0	0	0	0	0	0	0	0	
Blue	---	0	0	0	0	0	0	0	0	0	0	0	0	0	0	0	0	1	1	1	1	1	1	1	1	1	1	1	
Green	---	0	0	0	0	0	0	0	0	1	1	1	1	1	1	1	1	0	0	0	0	0	0	0	0	0	0	0	
Cyan	---	0	0	0	0	0	0	0	0	1	1	1	1	1	1	1	1	1	1	1	1	1	1	1	1	1	1	1	
Red	---	1	1	1	1	1	1	1	1	0	0	0	0	0	0	0	0	0	0	0	0	0	0	0	0	0	0	0	
Magenta	---	1	1	1	1	1	1	1	1	0	0	0	0	0	0	0	0	1	1	1	1	1	1	1	1	1	1	1	
Yellow	---	1	1	1	1	1	1	1	1	1	1	1	1	1	1	1	1	0	0	0	0	0	0	0	0	0	0	0	
White	---	1	1	1	1	1	1	1	1	1	1	1	1	1	1	1	1	1	1	1	1	1	1	1	1	1	1	1	
Black	R0	0	0	0	0	0	0	0	0	0	0	0	0	0	0	0	0	0	0	0	0	0	0	0	0	0	0	0	
Darker	R1	1	0	0	0	0	0	0	0	0	0	0	0	0	0	0	0	0	0	0	0	0	0	0	0	0	0	0	
	R2	0	1	0	0	0	0	0	0	0	0	0	0	0	0	0	0	0	0	0	0	0	0	0	0	0	0	0	
Brighter		:	:	:	:	:	:	:	:	:	:	:	:	:	:	:	:	:	:	:	:	:	:	:	:	:	:	:	
		:	:	:	:	:	:	:	:	:	:	:	:	:	:	:	:	:	:	:	:	:	:	:	:	:	:	:	
	R253	1	0	1	1	1	1	1	1	0	0	0	0	0	0	0	0	0	0	0	0	0	0	0	0	0	0	0	
	R254	0	1	1	1	1	1	1	1	0	0	0	0	0	0	0	0	0	0	0	0	0	0	0	0	0	0	0	
Red	R255	1	1	1	1	1	1	1	1	0	0	0	0	0	0	0	0	0	0	0	0	0	0	0	0	0	0	0	
Black	G0	0	0	0	0	0	0	0	0	0	0	0	0	0	0	0	0	0	0	0	0	0	0	0	0	0	0	0	
Darker	G1	0	0	0	0	0	0	0	0	1	0	0	0	0	0	0	0	0	0	0	0	0	0	0	0	0	0	0	
	G2	0	0	0	0	0	0	0	0	0	1	0	0	0	0	0	0	0	0	0	0	0	0	0	0	0	0	0	
Brighter		:	:	:	:	:	:	:	:	:	:	:	:	:	:	:	:	:	:	:	:	:	:	:	:	:	:	:	
		:	:	:	:	:	:	:	:	:	:	:	:	:	:	:	:	:	:	:	:	:	:	:	:	:	:	:	
	G253	0	0	0	0	0	0	0	0	1	0	1	1	1	1	1	1	0	0	0	0	0	0	0	0	0	0	0	
	G254	0	0	0	0	0	0	0	0	0	1	1	1	1	1	1	1	0	0	0	0	0	0	0	0	0	0	0	
Green	G255	0	0	0	0	0	0	0	0	1	1	1	1	1	1	1	1	0	0	0	0	0	0	0	0	0	0	0	
Black	B0	0	0	0	0	0	0	0	0	0	0	0	0	0	0	0	0	0	0	0	0	0	0	0	0	0	0	0	
Darker	B1	0	0	0	0	0	0	0	0	0	0	0	0	0	0	0	0	1	0	0	0	0	0	0	0	0	0	0	
	B2	0	0	0	0	0	0	0	0	0	0	0	0	0	0	0	0	0	1	0	0	0	0	0	0	0	0	0	
Brighter		:	:	:	:	:	:	:	:	:	:	:	:	:	:	:	:	:	:	:	:	:	:	:	:	:	:	:	
		:	:	:	:	:	:	:	:	:	:	:	:	:	:	:	:	:	:	:	:	:	:	:	:	:	:	:	
	B253	0	0	0	0	0	0	0	0	0	0	0	0	0	0	0	0	1	0	1	1	1	1	1	1	1	1	1	
	B254	0	0	0	0	0	0	0	0	0	0	0	0	0	0	0	0	0	1	1	1	1	1	1	1	1	1	1	
Blue	B255	0	0	0	0	0	0	0	0	0	0	0	0	0	0	0	0	1	1	1	1	1	1	1	1	1	1	1	

## Product Specification

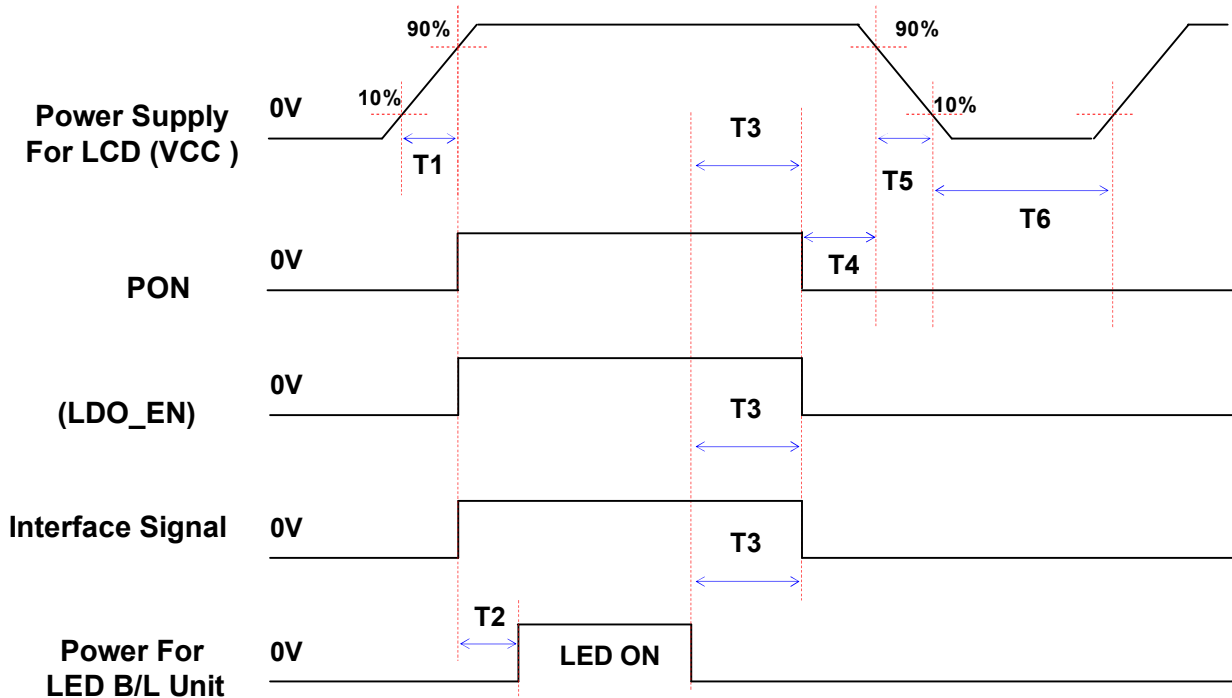
**3-6. Power Sequence**

**Table 8. POWER SEQUENCE TABLE**

Parameter	Value			Units	Remarks
	Min.	Typ.	Max.		
T <sub>1</sub>	-	-	10	(ms)	
T <sub>2</sub>	100	-	-	(ms)	
T <sub>3</sub>	50	-	-	(ms)	
T <sub>4</sub>	20	-	-	(ms)	
T <sub>5</sub>	0	-	-	(ms)	
T <sub>6</sub>	400	-	-	(ms)	

Note)

1. Please avoid floating state of interface signal at invalid period.
2. When the interface signal is invalid, be sure to pull down the power supply for LCD VCC to 0V.
3. PON & Interface Signal should be turn on the same time with VCC.
4. If the LDO of system use Enable signal, turn on the Enable signal at the same time with VCC.
5. LED power must be turn on after power supply for LCD and interface signal are valid.

Product Specification

**4. Optical Specifications**

Optical characteristics are determined after the unit has been 'ON' and stable for approximately 5 minutes in a dark environment at 25°C. The values specified are at an approximate distance 50cm from the LCD surface at a viewing angle of  $\Phi$  and  $\Theta$  equal to 0°.

FIG. 1 presents additional information concerning the measurement equipment and method.

**FIG. 1 Optical Characteristic Measurement Equipment and Method**

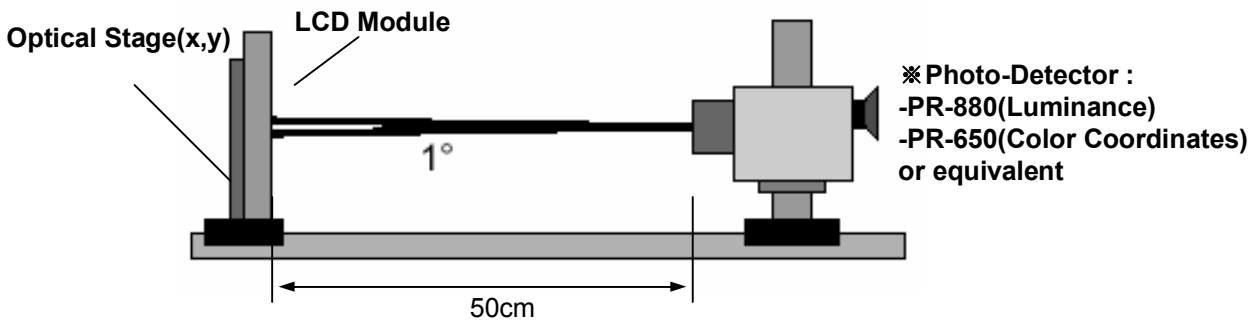

**Table 9. OPTICAL CHARACTERISTICS**

Ta=25°C, VCC=3.3V, fv=60Hz, fCLK= 33.26MHz, ILED = 20.0mA

Parameter	Symbol	Values			Units	Notes
		Min	Typ	Max		
Contrast Ratio	CR	400	500	-		1
Surface Luminance, white	L <sub>WH</sub>	280	350	-	cd/m <sup>2</sup>	2
Luminance Variation	$\delta_{WHITE}$	-	1.4	1.6		3
Response Time						4
: Rise Time	Tr <sub>R</sub>	-	10	20	ms	
: Decay Time	Tr <sub>D</sub>	-	15	25	ms	
Color Coordinates						2
: Red	RX	0.526	0.576	0.626		
:	RY	0.290	0.340	0.390		
: Green	GX	0.310	0.360	0.410		
:	GY	0.548	0.598	0.648		
: Blue	BX	0.111	0.161	0.211		
:	BY	0.062	0.112	0.162		
: White	WX	0.263	0.313	0.363		
:	WY	0.279	0.329	0.379		
Viewing Angle						5
: x axis, right( $\Phi=0^\circ$ )	$\Theta_r$	55	65	-	degree	3 o'clock
: x axis, left ( $\Phi=180^\circ$ )	$\Theta_l$	55	65	-	degree	9 o'clock
: y axis, up ( $\Phi=90^\circ$ )	$\Theta_u$	40	50	-	degree	12 o'clock
: y axis, down ( $\Phi=270^\circ$ )	$\Theta_d$	50	60	-	degree	6 o'clock
Gray Scale						6

## Product Specification

Note)

1. Contrast Ratio(CR) is defined mathematically as

$$\text{Contrast Ratio} = \frac{\text{Surface Luminance with all white pixels}}{\text{Surface Luminance with all black pixels}}$$

2. Surface luminance is measured at the center point(L<sub>1</sub>) of the LCD with all pixels displaying white at the distance of 50cm by PR-880. Color Coordinates are measured at the center point(L<sub>1</sub>) of the LCD with all pixels displaying red, green, blue and white at the distance of 50cm by PR-650. For more information, refer to the FIG 1 and FIG 2.
3. Luminance % uniformity is measured for 9 point For more information see FIG 2.  
 $\delta \text{ WHITE} = \text{Maximum}(L_1, L_2, \dots, L_9) \div \text{Minimum}(L_1, L_2, \dots, L_9)$
4. Response time is the time required for the display to transition from white to black (Rise Time, Tr<sub>R</sub>) and from black to white(Decay Time, Tr<sub>D</sub>). For additional information see FIG 3.
5. Viewing angle is the angle at which the contrast ratio is greater than 10. The angles are determined for the horizontal or x axis and the vertical or y axis with respect to the z axis which is normal to the LCD surface. For more information see FIG 4.
6. Gray scale specification (Recommendation)

Gray Level	Luminance [%] (Typ)
G0	0.17
G31	0.78
G63	3.40
G95	10.60
G127	18.90
G159	32.70
G191	51.20
G223	72.20
G255	100

Product Specification

**FIG. 2 Luminance**

<measuring point for surface luminance & measuring point for luminance variation>

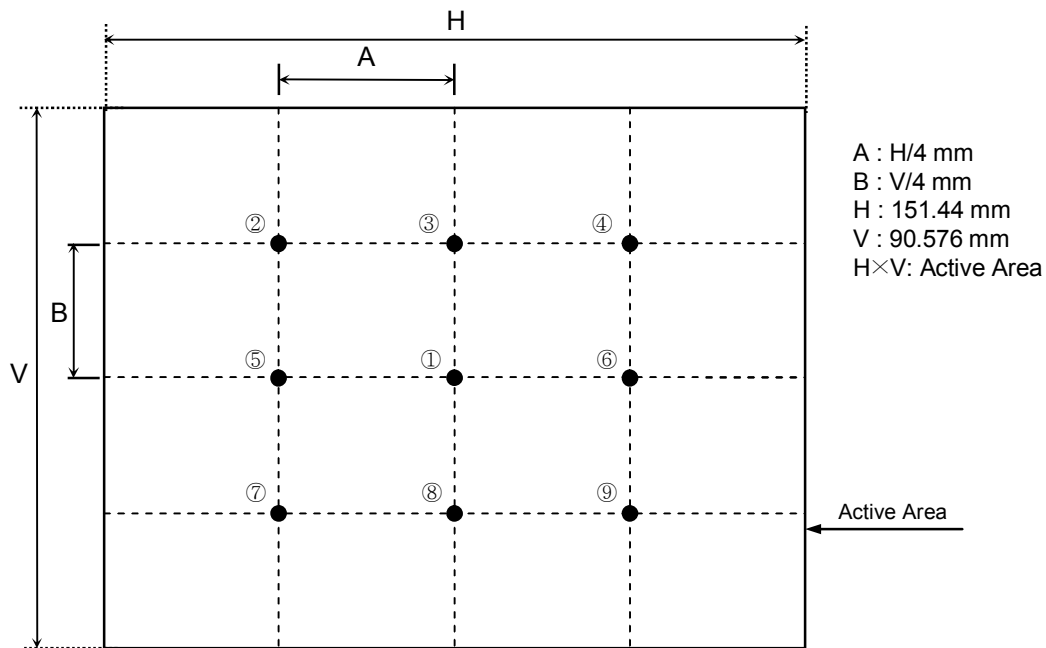

**FIG. 3 Response Time**

The response time is defined as the following figure and shall be measured by switching the input signal for “black” and “white”.

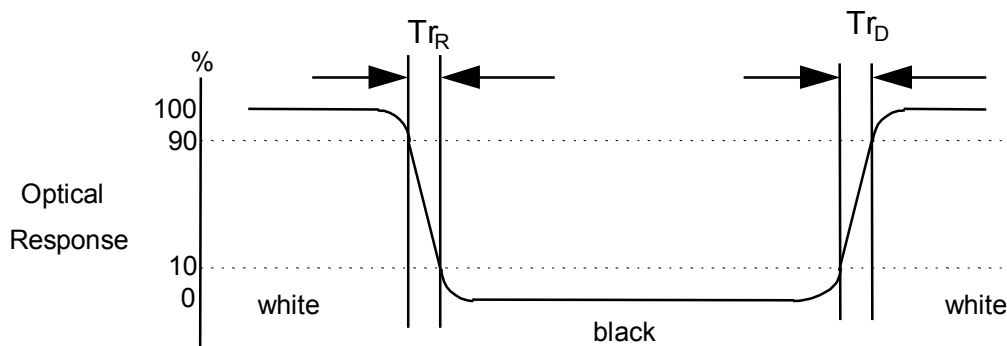

Product Specification

FIG. 4 Viewing angle

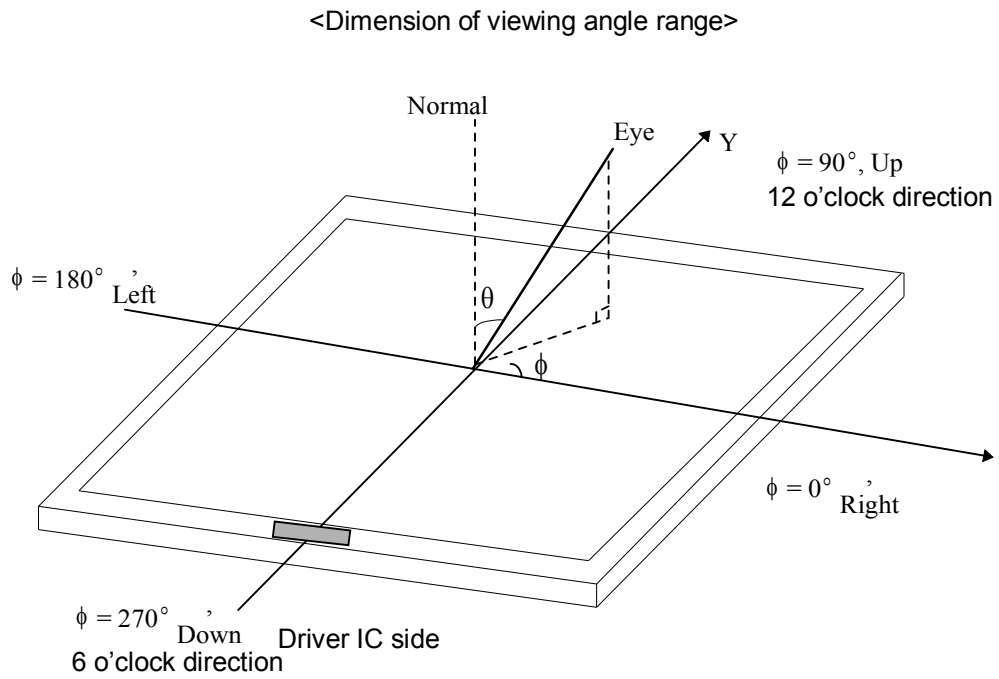

## Product Specification

**5. Mechanical Characteristics**

The contents provide general mechanical characteristics for the model LB070WV6. In addition the figures in the next page are detailed mechanical drawing of the LCD.

Outline Dimension	Horizontal	165 mm(Typ)
	Vertical	104.6 mm(Typ)
	Depth	3.3 mm (Typ.)
Bezel Area	Horizontal	158.44 mm (Typ.)
	Vertical	93.526 mm (Typ.)
Active Display Area	Horizontal	151.44 mm (Typ.)
	Vertical	90.576 mm (Typ.)
Weight	107.7g(Typ), 112g(Max.)	
Surface Treatment	Anti-glare treatment of the front polarizer	



Product Specification

<FRONT VIEW>

Note) Unit:[mm], General tolerance:  $\pm 0.3$ mm

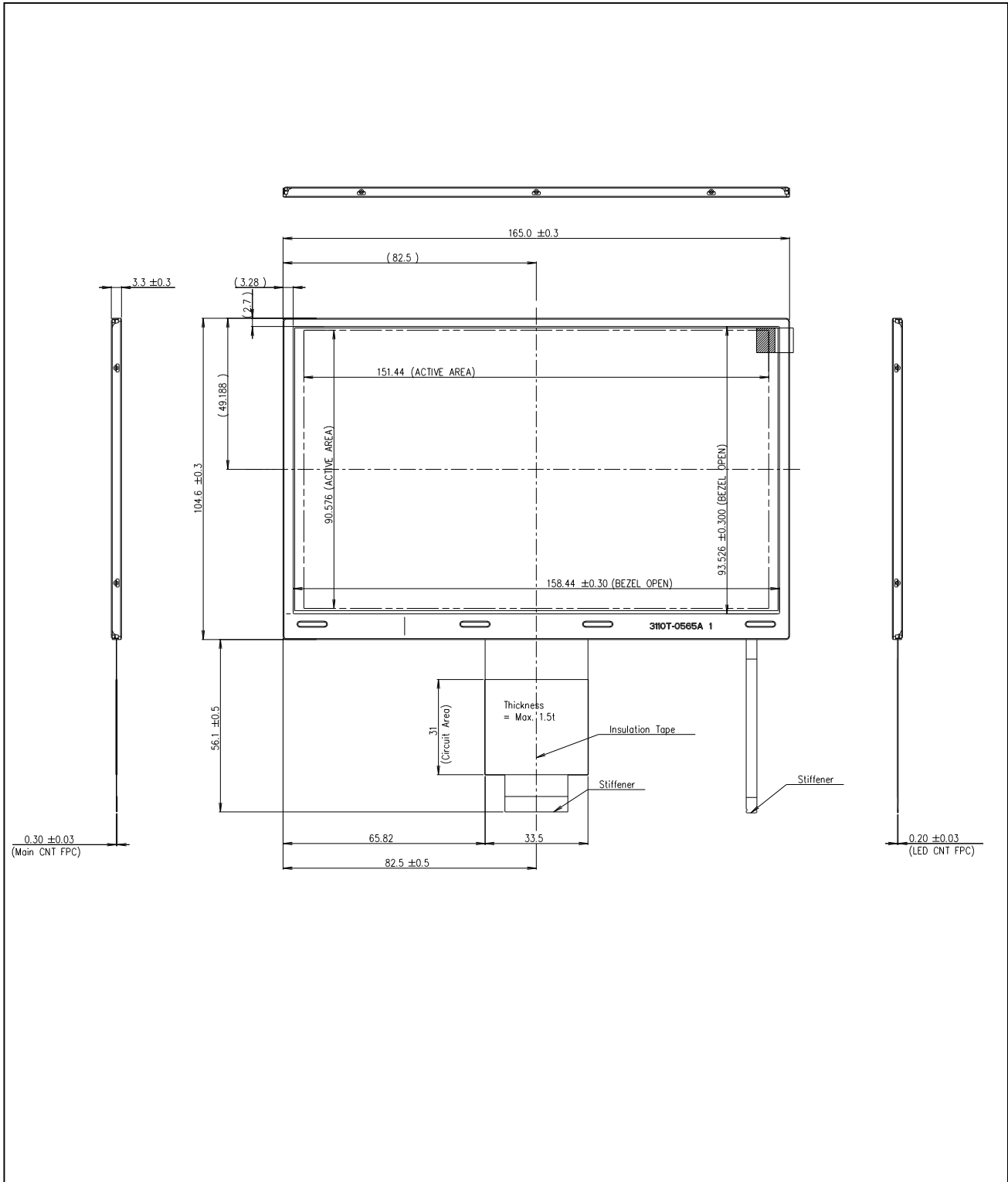

Product Specification

<REAR VIEW>

Note) Unit:[mm], General tolerance:  $\pm 0.3$ mm

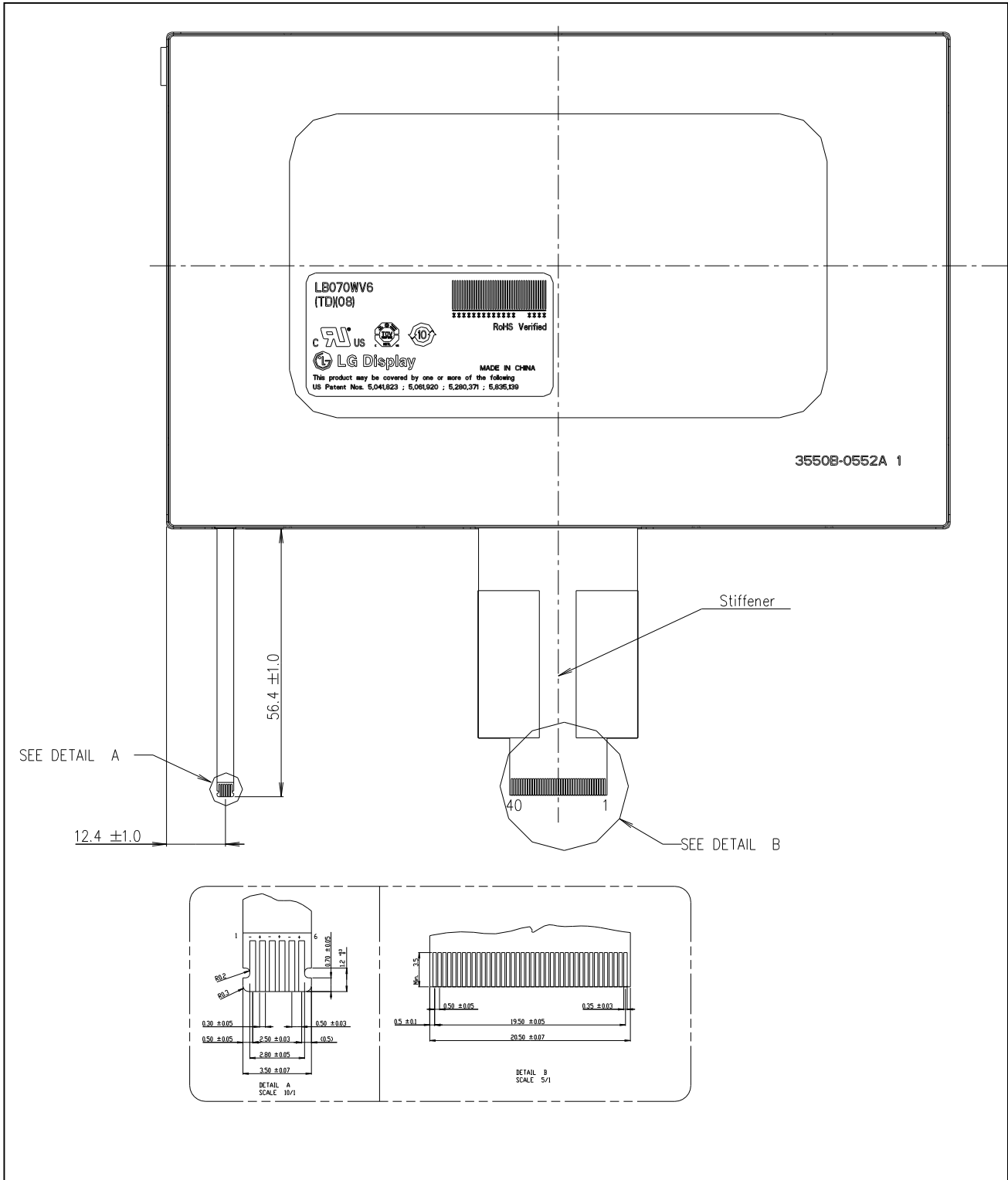

## Product Specification

## 6. Reliability

Environment test condition

No.	Test Item	Conditions	Note
1	High Temperature Storage Test	Ta=+80℃ 240h	6-1,2,3
2	Low Temperature Storage Test	Ta=-30℃ 240h	6-1,2,3
3	High Temperature Operation Test	Tp=+70℃ 240h	6-1,2,3
4	Low Temperature Operation Test	Ta=-20℃ 240h	6-1,2,3
5	High Temperature and High Humidity Operation Test	Ta=60℃ 90%RH 240h	6-1,2,3
6	Vibration test (non-operating)	Sine wave, 10 ~ 500 ~ 10Hz, 1.5G, 0.37oct/min 3 axis, 1hour/axis	
7	Shock test (non-operating)	Half sine wave, 180G, 2ms, 1 times shock of each six faces (±X / ±Y / ±Z)	
8	Thermal Shock Test (non-operating)	-30℃(0.5h) ~ 80℃(0.5h) / 100 cycles	

Note)

[Note 6-1] Ta = Ambient Temperature, Tp= Panel Temperature

[Note 6-2] In the Reliability Test, Confirm performance after leaving in room temp.

[Note 6-3] In the standard condition, there shall be no practical problems that may affect the display function 24 hours later after reliability test.

{ Result Evaluation Criteria }

There should be no change which might affect the practical display function when the display quality test is conducted under normal operating condition.

## 7. International Standards

### 7-1. Safety

- a) UL 60950-1, Second Edition, Underwriters Laboratories Inc.  
Information Technology Equipment - Safety - Part 1 : General Requirements.
- b) CAN/CSA C22.2 No.60950-1-07, Second Edition, Canadian Standards Association.  
Information Technology Equipment - Safety - Part 1 : General Requirements.
- c) EN 60950-1:2006 + A11:2009, European Committee for Electrotechnical Standardization(CENELEC).  
Information Technology Equipment - Safety - Part 1 : General Requirements.

### 7-2. EMC

- a) ANSI C63.4 – 2003 “American National Standard for Methods of Measurement of Radio-Noise Emissions from Low-Voltage Electrical and Electronic Equipment in the Range of 9 kHz to 40 GHz.” American National Standards Institute (ANSI), 2003.
- b) C.I.S.P.R. Pub. 22. Limits and methods of measurement of radio interference characteristics of information technology equipment." International Special Committee on Radio Interference (C.I.S.P.R.), 2005.
- c) EN 55022 "Limits and methods of measurement of radio interference characteristics of information technology equipment." European Committee for Electrotechnical Standardization (CENELEC), 2006.

### 7-3. Environment

- a) RoHS, Directive 2002/95/EC of the European Parliament and of the council of 27 January 2003

Product Specification

## 8. Packing

### 8-1. Designation of Lot Mark

a) Lot Mark

A	B	C	D	E	F	G	H	I	J	K	L	M
---	---	---	---	---	---	---	---	---	---	---	---	---

A,B,C : SIZE(INCH)  
E : MONTH

D : YEAR  
F ~ M : SERIAL NO.

Note

1. YEAR

Year	2001 2011	2002 2012	2003 2013	2004 2014	2005 2015	2006 2016	2007 2017	2008 2018	2009 2019	2010 2011
Mark	1	2	3	4	5	6	7	8	9	0

2. MONTH

Month	Jan	Feb	Mar	Apr	May	Jun	Jul	Aug	Sep	Oct	Nov	Dec
Mark	1	2	3	4	5	6	7	8	9	A	B	C

b) Location of Lot Mark

Serial No. is printed on the label. The label is attached to the backside of the LCD module.  
This is subject to change without prior notice.

### 8-2. Packing Form

a) Package quantity in one box : 40 pcs

b) Box Size : 475 mm × 348 mm × 182 mm

## 9. PRECAUTIONS

Please pay attention to the followings when you use this TFT LCD module.

### 9-1. MOUNTING PRECAUTIONS

- (1) You must mount a module using holes arranged in four corners.
- (2) If there are not mounting holes in four corners, module can be mounted directly by using four sides.
- (3) You should consider the mounting structure so that uneven force (ex. Twisted stress) is not applied to the module. And the case on which a module is mounted should have sufficient strength so that external force is not transmitted directly to the module.
- (4) Please attach the surface transparent protective plate to the surface in order to protect the polarizer. Transparent protective plate should have sufficient strength in order to the resist external force.
- (5) You should adopt radiation structure to satisfy the temperature specification.
- (6) Acetic acid type and chlorine type materials for the cover case are not desirable because the former generates corrosive gas of attacking the polarizer at high temperature and the latter causes circuit break by electro-chemical reaction.
- (7) Do not touch, push or rub the exposed polarizers with glass, tweezers or anything harder than HB pencil lead. And please do not rub with dust clothes with chemical treatment. Do not touch the surface of polarizer for bare hand or greasy cloth.(Some cosmetics are detrimental to the polarizer.)
- (8) When the surface becomes dusty, please wipe gently with absorbent cotton or other soft materials like chamois soaks with petroleum benzene. Normal-hexane is recommended for cleaning the adhesives used to attach front / rear polarizers. Do not use acetone, toluene and alcohol because they cause chemical damage to the polarizer.
- (9) Wipe off saliva or water drops as soon as possible. Their long time contact with polarizer causes deformations and color fading.
- (10) Do not open the case because inside circuits do not have sufficient strength.

### 9-2. OPERATING PRECAUTIONS

- (1) The spike noise causes the mis-operation of circuits. It should be lower than following voltage :  
 $V = \pm 200\text{mV}$ (Over and under shoot voltage)
- (2) Response time depends on the temperature.(In lower temperature, it becomes longer.)
- (3) Brightness depends on the temperature. (In lower temperature, it becomes lower.)  
And in lower temperature, response time(required time that brightness is stable after turned on) becomes longer.
- (4) Be careful for condensation at sudden temperature change. Condensation makes damage to polarizer or electrical contacted parts. And after fading condensation, smear or spot will occur.
- (5) When fixed patterns are displayed for a long time, remnant image is likely to occur.
- (6) Module has high frequency circuits. Sufficient suppression to the electromagnetic interference shall be done by system manufacturers. Grounding and shielding methods may be important to minimized the interference.

### 9-3. ELECTROSTATIC DISCHARGE CONTROL

Since a module is composed of electronic circuits, it is not strong to electrostatic discharge. Make certain that treatment persons are connected to ground through wrist band etc. And don't touch interface pin directly.

### 9-4. PRECAUTIONS FOR STRONG LIGHT EXPOSURE

Strong light exposure causes degradation of polarizer and color filter.

### 9-5. STORAGE

When storing modules as spares for a long time, the following precautions are necessary.

- (1) Store them in a dark place. Do not expose the module to sunlight or fluorescent light. Keep the temperature between 5°C and 35°C at normal humidity.
- (2) The polarizer surface should not come in contact with any other object.  
It is recommended that they be stored in the container in which they were shipped.

### 9-6. HANDLING PRECAUTIONS FOR PROTECTION FILM

- (1) When the protection film is peeled off, static electricity is generated between the film and polarizer.  
This should be peeled off slowly and carefully by people who are electrically grounded and with well ion-blown equipment or in such a condition, etc.
- (2) The protection film is attached to the polarizer with a small amount of glue. If some stress is applied to rub the protection film against the polarizer during the time you peel off the film, the glue is apt to remain on the polarizer.  
Please carefully peel off the protection film without rubbing it against the polarizer.
- (3) When the module with protection film attached is stored for a long time, sometimes there remains a very small amount of glue still on the polarizer after the protection film is peeled off.
- (4) You can remove the glue easily. When the glue remains on the polarizer surface or its vestige is recognized, please wipe them off with absorbent cotton waste or other soft material like chamois soaked with normal-hexane.