

Product Specification

SPECIFICATION FOR APPROVAL

- (●) Preliminary Specification
 () Final Specification

Title	8.4" SVGA TFT LCD
-------	-------------------

Customer	
Project	

SUPPLIER	LG.Philips LCD Co., Ltd.
MODEL	LB084S01
Suffix	TL01

SIGNATURE	DATE
/	_____
/	_____
/	_____

Please return 1 copy for your confirmation with your signature and comments.

SIGNATURE	DATE
C.S. Kyoung / G.Manager	_____
REVIEWED BY	_____
S.D.Jung / S.Manager	_____
PREPARED BY	_____
W.Y.Sun / Engineer	_____

**Products Engineering Dept.
 LG. Philips LCD Co., Ltd**

Product Specification

Contents

No	ITEM	Page
	COVER	1
	CONTENTS	2
	RECORD OF REVISIONS	3
1	GENERAL DESCRIPTION	4
2	ABSOLUTE MAXIMUM RATINGS	5
3	ELECTRICAL SPECIFICATIONS	
3-1	ELECTRICAL CHARACTREISTICS	6
3-2	INTERFACE CONNECTIONS	8
3-3	CONNECTION BETWEEN HOST SYSTEM AND LVDS RECIEVER	10
3-4	SIGNAL TIMING SPECIFICATIONS	13
3-5	SIGNAL TIMING WAVEFORMS	15
3-6	DISPLAY COLOR AND INPUT SIGNALS	16
3-7	POWER SEQUENCE	19
3-8	SCANNING DIRECTIONS	20
4	OPTICAL SFECIFICATIONS	22
5	MECHANICAL CHARACTERISTICS	24
6	RELIABILITY	29
7	INTERNATIONAL STANDARDS	
7-1	SAFETY	30
7-2	EMC	30
8	PACKING	
8-1	DESIGNATION OF LOT MARK	31
8-2	PACKING FORM	32
9	PRECAUTIONS	33

Product Specification

1. General Description

The LB084S01 is a Color Active Matrix Liquid Crystal Display with an integral Cold Cathode Fluorescent Lamp (CCFL) backlight system. The matrix employs a-Si Thin Film Transistor as the active element. It is a transmissive type display operating in the normally white mode. This TFT-LCD has 8.4 inches diagonally measured active display area with SVGA resolution(600 vertical by 800 horizontal pixel array). Each pixel is divided into Red, Green and Blue sub-pixels or dots which are arranged in vertical stripes. Gray scale or the brightness of the sub-pixel color is determined with a 8-bit(or 6-bit) gray scale signal for each dot, thus, presenting a palette of more than 16,777,216(or 262,144) colors.

The LB084S01 has been designed to apply the interface method that enables low power, high speed, low EMI.

The LB084S01 is intended to support applications where thin thickness, low power are critical factors and graphic displays are important. In combination with the vertical arrangement of the sub-pixels, the LB084S1 characteristics provide an excellent flat display for office automation products such as Mini-Notebook PC or Web-pad, etc.

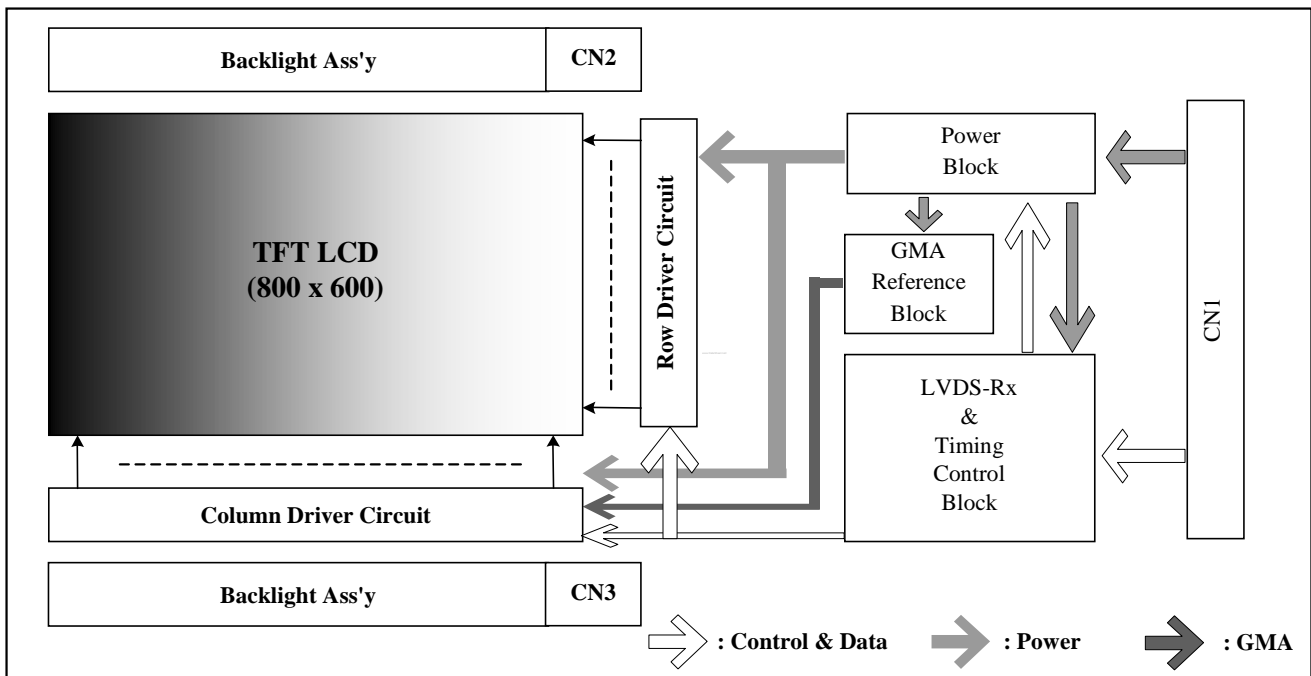

General Features

Active Screen Size	8.4 inches (213mm) diagonal
Outline Dimension	189.5(H) x 148.6(V) x 9.1(D) mm(Typ.)
Main Viewing Angle	12 o'clock =up side (viewing direction with image reversal)
Pixel Pitch	0.2130(H) mm x 0.2130(V)mm
Pixel Format	800(H) By 600 (V) Pixels RGB stripes arrangement
Color Depth	16,777,216 colors(At 8-bit input) 262,144 colors(At 6-bit input)
Luminance, White	600 cd/m ² (Typ.)
Power Consumption	0.61Watt (Typ. Only module)
Weight	330. (Max.)
Display Operating Mode	Transmissive mode, normally white
Surface Treatment	Anti-glare & hard coating(3H)

Product Specification

2. Absolute Maximum Ratings

The following are maximum values which, if exceeded, may cause faulty operation or damage to the unit.

Table 1. ABSOLUTE MAXIMUM RATINGS

Parameter	Symbol	Values		Units	Notes
		Min	Max		
Power Supply Voltage	VCC	-0.3	4.0	Vdc	at 25 ± 5°C
Input Voltage for Signal	VDis	-0.3	VCC+0.3	Vdc	2
Operating Temperature	TOP	-10	70	°C	1
Storage Temperature	HST	-20	80	°C	1
Operating Ambient Humidity	HOP	10	90	%RH	1
Storage Humidity	HST	10	90	%RH	1

Notes : 1. Temperature and relative humidity range are shown in the figure below.
 Wet bulb temperature should be 58°C Max, and no condensation of water.
 2. D0+/-, D1+/-, D2+/-, CK+/-, D3+/-, DIR, FRC

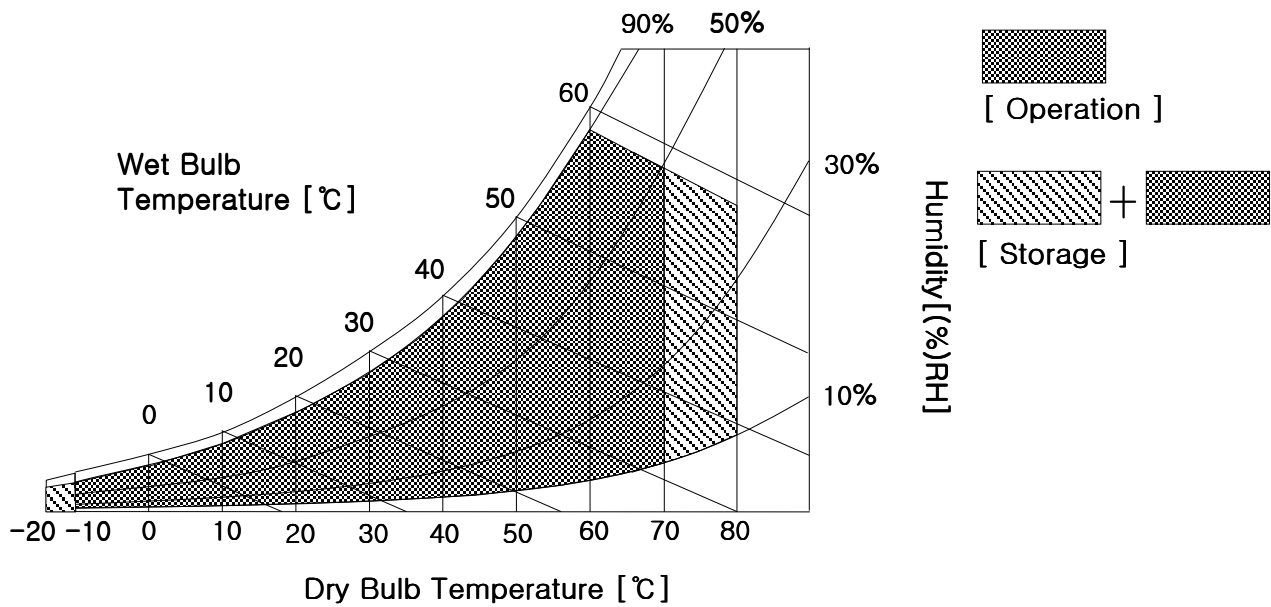

Note : This document is preliminary version. The latest version must be checked from LG.Philips LCD before detail design.

Product Specification

3. Electrical Specifications

3-1. Electrical Characteristics

The LB084S01 requires three power inputs. CN1 is employed to power the LCD electronics and to drive the TFT array and liquid crystal. CN2 and CN3 input which powers the CCFL, are typically generated by two inverters. The inverters are external unit to the LCD.

Table 2. ELECTRICAL CHARACTERISTICS

Parameter	Symbol	Values			Unit	Notes	
		Min	Typ	Max			
MODULE :							
Power Supply Input Voltage	VCC	3.0	3.3	3.6	V _{DC}		
DIR and FRC Input Voltage	High	V _{FH}	3.0	3.3	3.6	V	
	Low	V _{FL}	0	-	0.5	V	
Power Supply Input Current	I _{CC}	-	0.184	0.212	A	1	
Power Consumption	P _c	-	0.61	0.70	Watt	1	
Differential Impedance	Z _m	90	100	110	Ohm	2	
LAMP :							
Operating Voltage	V _{BL}	380 (8 mA _{RMS})	400 (7 mA _{RMS})	480 (3 mA _{RMS})	V _{RMS}	3	
Operating Current	I _{BL}	3.0	7.0	8.0	mA _{RMS}	4	
Power Consumption	P _{BL}	-	5.6	6.2	W	5	
Operating Frequency	f _{BL}	35	60	80	kHz	6	
Discharge Stabilization Time	T _s	-	-	3	Min	7	
Life Time		20,000	30,000	-	Hrs	8	
Established Starting Voltage	Vs	at 25°C	-	-	800	V _{RMS}	9
		at 0 °C	-	-	1050	V _{RMS}	

Notes :

1. The specified current and power consumption are under the VCC = 3.3V, 25°C, 8bit, fv=60Hz condition whereas mosaic(8x6) pattern is displayed and fv is the frame frequency.

※ Mosaic pattern(8x6)

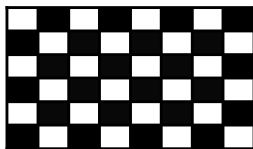

- This impedance value is needed to proper display and measured form LVDS Tx to the mating connector.
- The variance of the voltage is ± 10%
- The typical operating current is TBDmA_{RMS} for the typical surface luminance (L_{WH}) in optical characteristics.
- The lamp power consumption shown above does not include loss of external inverter.
The used lamp current is the lamp typical current. (P_{BL} = V_{BL} × I_{BL} × N_{Lamp})

Product Specification

6. The output of the inverter must have symmetrical(negative and positive) voltage waveform and symmetrical current waveform.(Asymmetrical ratio is less than 10%) Please do not use the inverter which has asymmetrical voltage and asymmetrical current and spike wave.
Lamp frequency may produce interface with horizontal synchronous frequency and as a result this may cause beat on the display. Therefore lamp frequency shall be as away possible from the horizontal synchronous frequency and from its harmonics in order to prevent interference.
7. Define the brightness of the lamp after being lighted for 5 minutes as 100%, Ts is the time required for the brightness of the center of the lamp to be not less than 95%.
8. The life time is determined as the time at which brightness of lamp is 50% compare to that of initial value at the typical lamp current
9. The voltage above Vs should be applied to the lamp for more than 1 second for start-up, Otherwise, the lamp may not be turned on, The used lamp current is the lamp typical current.
10. Requirements for a system inverter design, which is intended to have a better display performance, a better power efficiency and a more reliable lamp, are following.
It shall help increase the lamp lifetime and reduce leakage current.
 - a. The asymmetry rate of the inverter waveform should be less than 10%.
 - b. The distortion rate of the waveform should be within $\sqrt{2} \pm 10\%$.

* Inverter output waveform had better be more similar to ideal sine wave.

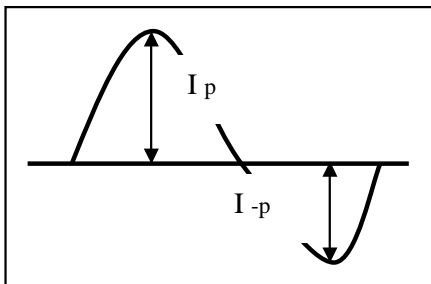

* Asymmetry rate:

$$\frac{|I_p - I_{-p}|}{I_{RMS}} * 100\%$$

* Distortion rate

$$I_p \text{ (or } I_{-p}) / I_{RMS}$$

- ※ Do not attach a conducting tape to lamp connecting wire.
If the lamp wire attach to a conducting tape, TFT-LCD Module has a low luminance and the inverter has abnormal action. Because leakage current is occurred between lamp wire and conducting tape.

Product Specification

3-2. Interface Connections

This LCD employs three interface connections, a 20 pin connector(CN1) is used for the module electronics interface and the other connectors(CN2&CN3) are used for the integral backlight system.

The electronics interface connector is a model GT100-20P-LS-SMT manufactured by LS Cable.

Table 3. MODULE CONNECTOR PIN CONFIGURATION (CN1)

Pin	Symbol	Description	Notes
1	D3+	Positive LVDS differential data input	Note 1
	GND	Ground	
2	D3-	Negative LVDS differential data input	Note 1
	GND	Ground	
3	DIR	Selection of scan direction	Note 2
4	FRC	Selection of number of color	Note 1
5	GND	Ground	
6	CK+	Positive LVDS differential clock input	Note 3
7	CK-	Negative LVDS differential clock input	Note 3
8	GND	Ground	
9	D2+	Positive LVDS differential data input	Note 3
10	D2-	Negative LVDS differential data input	Note 3
11	GND	Ground	
12	D1+	Positive LVDS differential data input	Note 3
13	D1-	Negative LVDS differential data input	Note 3
14	GND	Ground	
15	D0+	Positive LVDS differential data input	Note 3
16	D0-	Negative LVDS differential data input	Note 3
17	GND	Ground	
18	GND	Ground	
19	VCC	Power Supply, 3.3V Typ.	
20	VCC	Power Supply, 3.3V Typ.	

■ Interface chips
 - LCD : KE5M6U2730WFP (LCD Controller) including LVDS Receiver
 - System : THC63LVDM63R / 83R or Equivalent
 * Pin to Pin compatible with NS LVDS

■ Connector
 - LCD : GT100-20P-LS-SMT, LS Cable or Equivalent
 - Mating
 Discrete Wire type : DF19G-20S-1C(HIROSE)
 FPC Type : DF19G-20S-1F(HIROSE)
 - Connector pin arrangement

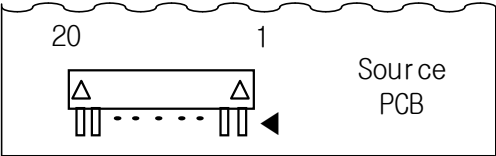

[LCD Module rear view]

Note1 : See “3-6. Display color and Input data signal”

Note2 : See “3.8. Scanning Directions”

Note3 : See “3.4. Signal Timing Specification”

Product Specification

The backlight interface connectors are model BHSR-02VS-2, manufactured by JST or Compatible.
The mating connector part number is SM02B-BHSS-1 or equivalent.

Table 4. BACKLIGHT CONNECTOR PIN CONFIGURATION (CN2 & CN3)

Pin	Symbol	Description	Wire color
1	HV	Power supply for lamp (High voltage side)	Pink
2	LV	Power supply for lamp (Low voltage side)	Black

Product Specification

3-3. Connection between Host system and LVDS receiver

Connection between Host system and LVDS receiver should be different by input signal condition(8bit or 6bit). Please refer to 3.3.1 and 3.3.2.

3.3.1 Input data signal : 8bit

If input data is 8bit, connect MSB 2bit of R,G,B to TD0~TD5 pin of LVDS Tx. Refer to FIG 1 and Table 5 for more detail.

FIG 1. REQUIRED SIGNAL ASSIGNMENT FOR LVDS TRANSMITTER(THC63LVDM83R)

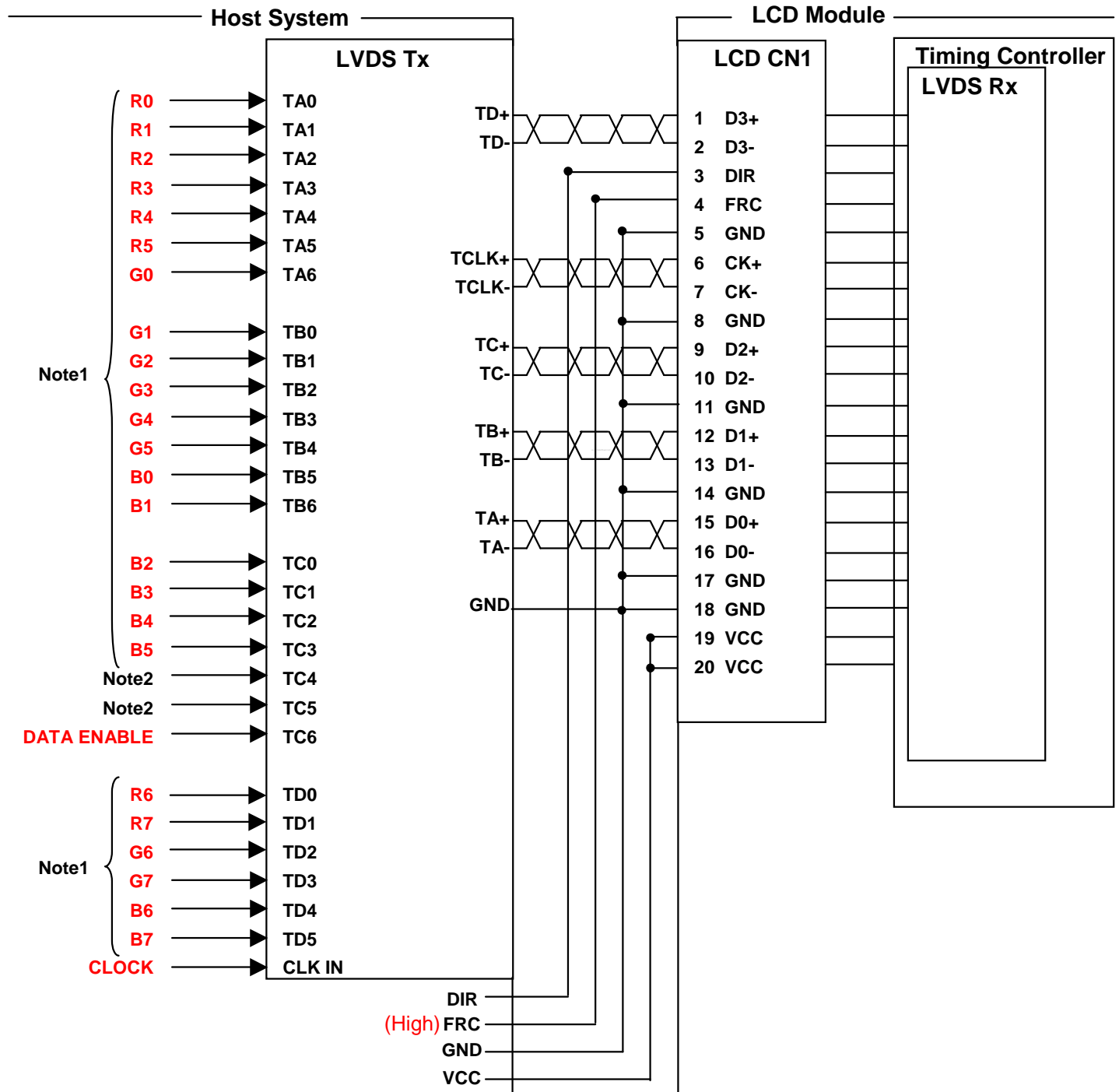

Note1 : See "Table 5. Input pin map of LVDS Tx for 8bit and 6bit"

Note2 : Connect to ground.

Product Specification

3.3.2 Input data signal : 6bit

If input data is 6bit, pin map of host system should be different with 8bit. Refer to FIG 2 for more detail.

FIG 2. REQUIRED SIGNAL ASSIGNMENT FOR LVDS TRANSMITTER(THC63LVDM83R)

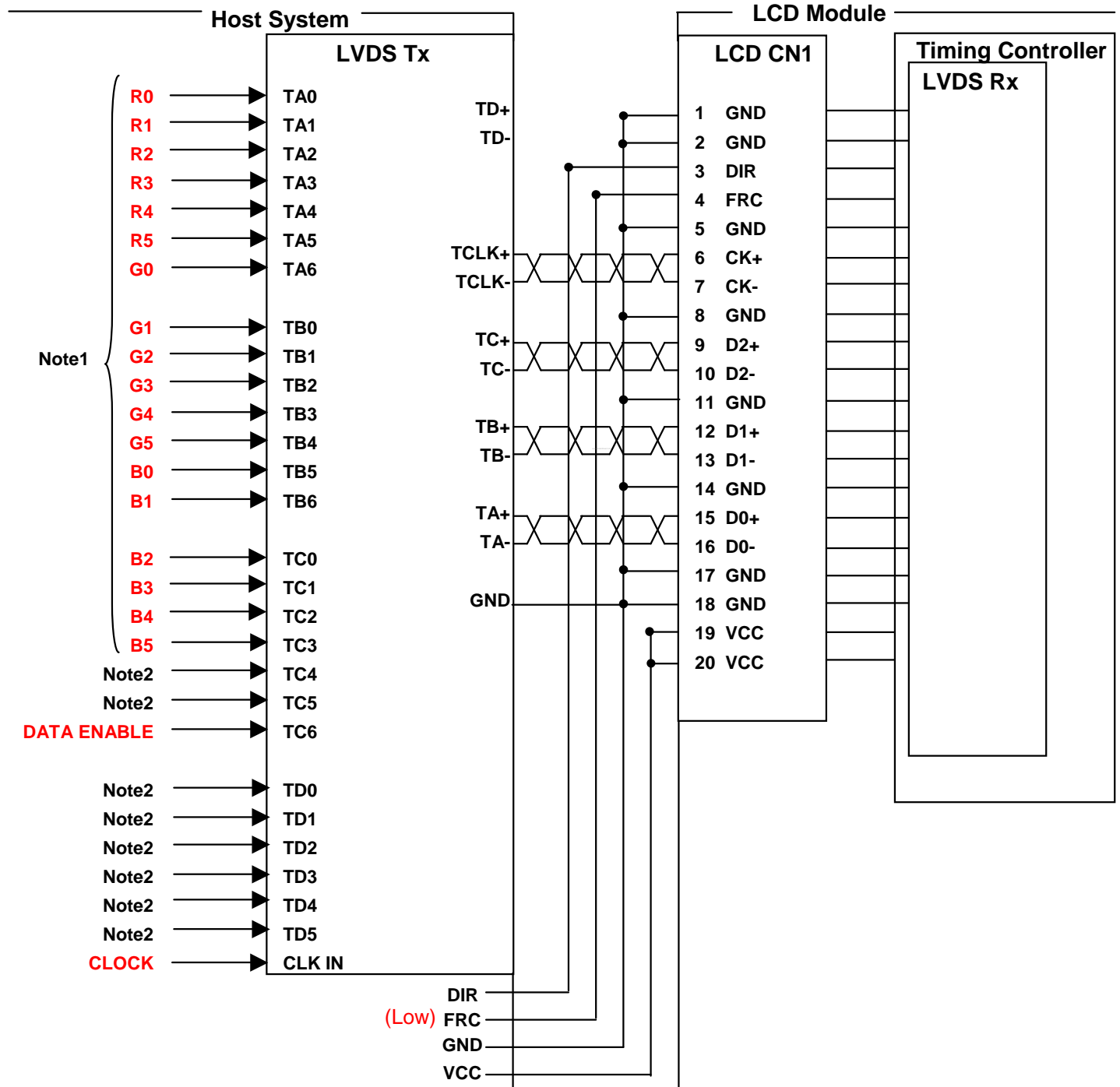

Note1 : R0(6bit) is not equal to R0(8bit). See "Table 5. Input pin map of LVDS Tx for 8bit and 6bit" for more detail.

Note2 : Connect to ground.

Product Specification

Table 5. Input pin map of LVDS Tx for 8bit and 6bit

TTL Data		LVDS Tx input Pin (Pin #)	TTL Data		LVDS Tx input Pin (Pin #)	Note
8bit			6Bit			
LSB	R0	TA0 (51)	LSB	-	-	
	R1	TA1 (52)		-	-	
	R2	TA2 (54)		R0	TA0 (51)	
	R3	TA3 (55)		R1	TA1 (52)	
	R4	TA4 (56)		R2	TA2 (54)	
	R5	TA5 (3)		R3	TA3 (55)	
	R6	TD0 (50)		R4	TA4 (56)	
MSB	R7	TD1 (2)	MSB	R5	TA5 (3)	
LSB	G0	TA6 (4)	LSB	-	-	
	G1	TB0 (6)		-	-	
	G2	TB1 (7)		G0	TA6 (4)	
	G3	TB2 (11)		G1	TB0 (6)	
	G4	TB3 (12)		G2	TB1 (7)	
	G5	TB4 (14)		G3	TB2 (11)	
	G6	TD2 (8)		G4	TB3 (12)	
MSB	G7	TD3 (10)	MSB	G5	TB4 (14)	
LSB	B0	TB5 (15)	LSB	-	-	
	B1	TB6 (19)		-	-	
	B2	TC0 (20)		B0	TB5 (15)	
	B3	TC1 (22)		B1	TB6 (19)	
	B4	TC2 (23)		B2	TC0 (20)	
	B5	TC3 (24)		B3	TC1 (22)	
	B6	TD4 (16)		B4	TC2 (23)	
MSB	B7	TD5 (18)	MSB	B5	TC3 (24)	
Data Enable		TC6 (30)	Data Enable		TC6 (30)	
CLOCK		CLKIN (31)	CLOCK		CLKIN (31)	

Note : LVDS Tx : THC63LVDM83R(Thine) or equivalent.

Product Specification

3-4. Signal Timing Specifications

This is the signal timing required at the input of the User connector. All of the interface signal timing should be satisfied with the following specifications and specifications of LVDS Tx(THC63LVDM63R or equivalent) / Rx for its proper operation.

Table 6-1. LVDS Input DC Specification

Symbol	Parameter	Min	Typ	Max	Unit
Vic	LVDS common voltage	0.6	1.2	1.8	V
Vth	LVDS differential High threshold	-	-	+100	mV
Vtl	LVDS differential Low threshold	-100	-	-	mV
Vid	LVDS differential Input voltage	100	-	600	mV
Iin	LVDS Input current	-	-	±10	μA

Table 6-2. LVDS Input AC Timing

Symbol	Parameter	Min	Typ	Max	Unit
tCLK	LVDS CLK Period	25	26	27	ns
tRIP1	Input Data Position 0	-0.4	0.0	0.4	ns
tRIP0	Input Data Position 1	T/7-0.4	T/7	T/7+0.4	ns
tRIP6	Input Data Position 2	2T/7-0.4	2T/7	2T/7+0.4	ns
tRIP5	Input Data Position 3	3T/7-0.4	3T/7	3T/7+0.4	ns
tRIP4	Input Data Position 4	4T/7-0.4	4T/7	4T/7+0.4	ns
tRIP3	Input Data Position 5	5T/7-0.4	5T/7	5T/7+0.4	ns
tRIP2	Input Data Position 6	6T/7-0.4	6T/7	6T/7+0.4	ns

※ T = Input CLKP period time
 ex) T= 26 ns @ SVGA, 60Hz

Product Specification

Table 6-3. TIMING TABLE

ITEM	Symbol		Min	Typ	Max	Unit	Notes
DCLK	Period	tCLK	25.0	26.0	27.0	ns	
	Frequency	fCLK	37.0	38.5	40.0	MHz	
Hsync	Period	tHP	990	1024	1100	tCLK	
	Width	tWH	16	64	120		
Vsync	Period	tVP	606	625	730	tHP	
	Width	tWV	1	6	24		
	Frequency	fV	51.5	60.2	62	Hz	
Data Enable	Horizontal Addr. time	tWHA	800	800	800	tCLK	
	Horizontal back porch	tHBP	32	88	120		
	Horizontal front porch	tHFP	32	72	80		
	Horizontal blank	-	76	~	tHP- tWHA		tWH+ tHBP+ tHFP
	Vertical Addr. Time	tWVA	600	600	600	tHP	
	Vertical back porch	tVBP	2	15	22		
	Vertical front porch	tVFP	3	4	5		
	Vertical blank	-	6	~	tVP-tWVA		tWV+ tVBP+tVFP

Notes

1. DE Only mode operation.
2. tHFP, tWH and tHBP should be any times of a character number (8).
3. No variation of the total number of Hsync and DE in a frame is required for normal operation.
4. No variation of the total number of clock in a Hsync period for tVBP is required for normal operation.

Product Specification

3-5. Signal Timing Waveforms

3.5.1 LVDS Rx input wave form

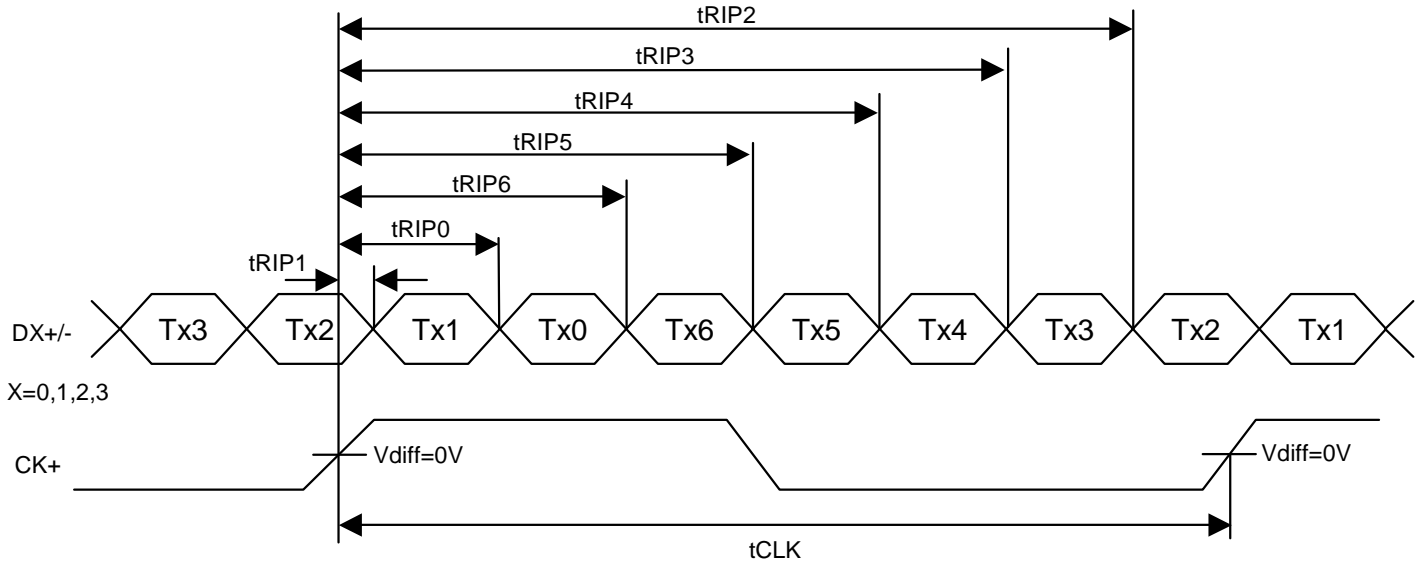

3.5.2 TTL wave form

Condition : VCC = 3.3V

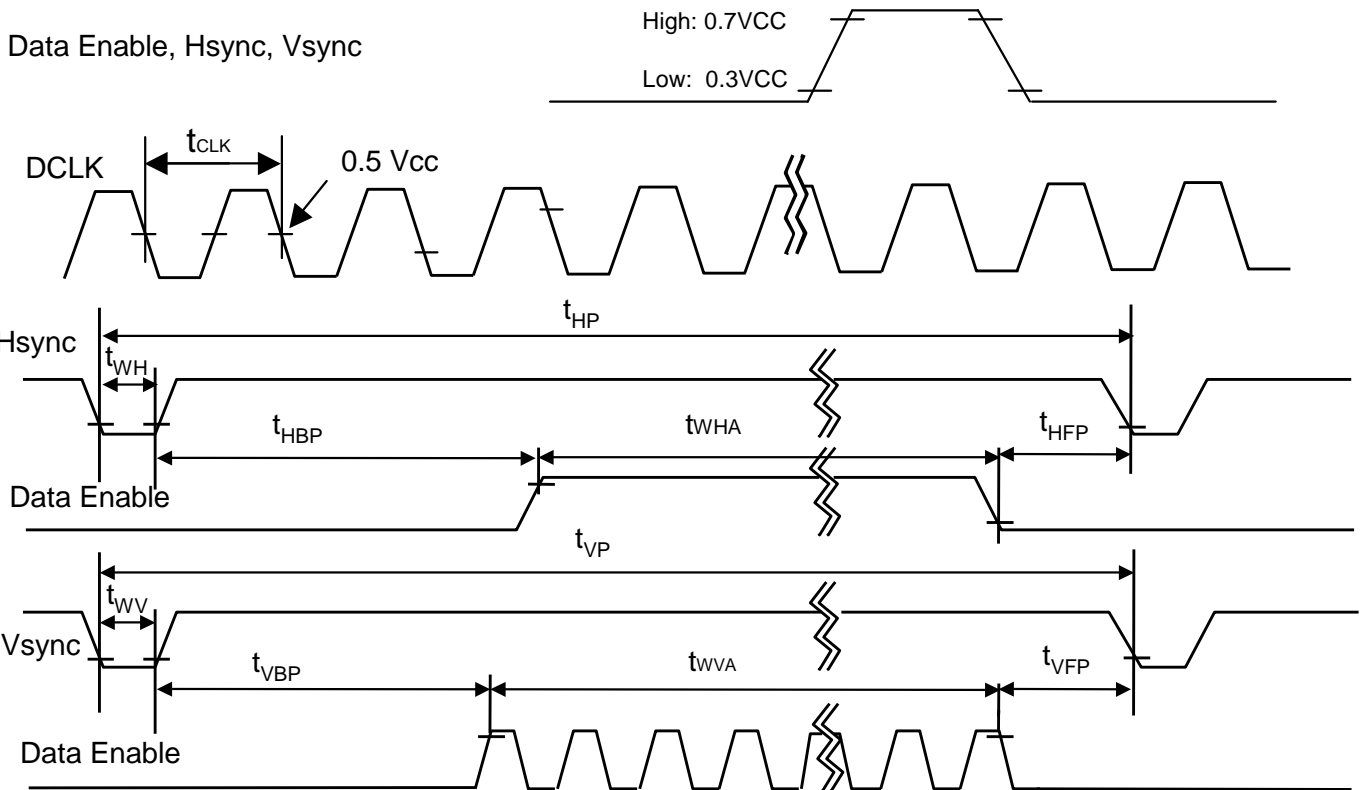

Product Specification

3-6. Display Color and Input Signals

3-6-1. Input Condition of FRC signal and data signals

LB084S01 can display 16,777,216 color in 256 gray scales and 262,144 colors in 64 gray scales by input condition of FRC signal and data signals. See following table.

Table 7. FRC and Input data signal

Input data signals	FRC terminal	Input signal for Pin 1 of CN1	Input signal for Pin 2 of CN1	Display color	Notes
8-bit	High	D3+	D3-	16,777,216	1,3
6-bit	Low	GND	GND	262,144	2,4

Note 1 : See "3-6-2.Color Input Data Reference(16,777,216)"

Note 2 : See "3-6-3. Color Input Data Reference(262,144)"

Note 3 : See "3-3-1. Input data signal : 8bit"

Note 4 : See "3-3-2. Input data signal : 6bit"

Product Specification

3-6-2. Color Input Data Reference(16,777,216 color)

The brightness of each primary color (red,green and blue) is based on the 8-bit gray scale data input for the color ; the higher the binary input, the brighter the color. The table below provides a reference for color versus data input. Please see “3-6-1. Input Condition of FRC signal and data signals” for 16,777,216 color.

Table 8-1. COLOR DATA REFERENCE

Color		Input Color Data																							
		RED								GREEN								BLUE							
		MSB				LSB				MSB				LSB				MSB				LSB			
		R7	R6	R5	R4	R3	R2	R1	R0	G7	G6	G5	G4	G3	G2	G1	G0	B7	B6	B5	B4	B3	B2	B1	B0
Basic Color	Black	0	0	0	0	0	0	0	0	0	0	0	0	0	0	0	0	0	0	0	0	0	0	0	0
	Red	1	1	1	1	1	1	1	1	0	0	0	0	0	0	0	0	0	0	0	0	0	0	0	0
	Green	0	0	0	0	0	0	0	0	1	1	1	1	1	1	1	1	0	0	0	0	0	0	0	0
	Blue	0	0	0	0	0	0	0	0	0	0	0	0	0	0	0	0	1	1	1	1	1	1	1	1
	Cyan	0	0	0	0	0	0	0	0	1	1	1	1	1	1	1	1	1	1	1	1	1	1	1	1
	Magenta	1	1	1	1	1	1	1	1	0	0	0	0	0	0	0	0	1	1	1	1	1	1	1	1
	Yellow	1	1	1	1	1	1	1	1	1	1	1	1	1	1	1	1	0	0	0	0	0	0	0	0
	White	1	1	1	1	1	1	1	1	1	1	1	1	1	1	1	1	1	1	1	1	1	1	1	1
RED	RED (000)	0	0	0	0	0	0	0	0	0	0	0	0	0	0	0	0	0	0	0	0	0	0	0	0
	RED (001)	0	0	0	0	0	0	0	1	0	0	0	0	0	0	0	0	0	0	0	0	0	0	0	0
							
	RED (255)	1	1	1	1	1	1	1	0	0	0	0	0	0	0	0	0	0	0	0	0	0	0	0	0
	RED (255)	1	1	1	1	1	1	1	1	0	0	0	0	0	0	0	0	0	0	0	0	0	0	0	0
GREEN	GREEN (000)	0	0	0	0	0	0	0	0	0	0	0	0	0	0	0	0	0	0	0	0	0	0	0	0
	GREEN (001)	0	0	0	0	0	0	0	0	0	0	0	0	0	0	0	1	0	0	0	0	0	0	0	0
							
	GREEN (255)	0	0	0	0	0	0	0	0	1	1	1	1	1	1	1	0	0	0	0	0	0	0	0	0
	GREEN (255)	0	0	0	0	0	0	0	0	1	1	1	1	1	1	1	1	0	0	0	0	0	0	0	0
BLUE	BLUE (000)	0	0	0	0	0	0	0	0	0	0	0	0	0	0	0	0	0	0	0	0	0	0	0	0
	BLUE (001)	0	0	0	0	0	0	0	0	0	0	0	0	0	0	0	0	0	0	0	0	0	0	0	1
							
	BLUE (254)	0	0	0	0	0	0	0	0	0	0	0	0	0	0	0	0	1	1	1	1	1	1	1	0
	BLUE (255)	0	0	0	0	0	0	0	0	0	0	0	0	0	0	0	0	1	1	1	1	1	1	1	1

Product Specification

3-6-3. Color Input Data Reference(262,144 color)

The brightness of each primary color (red,green and blue) is based on the 6-bit gray scale data input for the color ; the higher the binary input, the brighter the color. The table below provides a reference for color versus data input. Please see “3-6-1. Input Condition of FRC signal and data signals” for 262,144 color.

Table 8-2. COLOR DATA REFERENCE

Color		Input Color Data																	
		RED						GREEN						BLUE					
		MSB			LSB			MSB			LSB			MSB			LSB		
		R 5	R 4	R 3	R 2	R 1	R 0	G 5	G 4	G 3	G 2	G 1	G 0	B 5	B 4	B 3	B 2	B 1	B 0
Basic Color	Black	0	0	0	0	0	0	0	0	0	0	0	0	0	0	0	0	0	0
	Red	1	1	1	1	1	1	0	0	0	0	0	0	0	0	0	0	0	0
	Green	0	0	0	0	0	0	1	1	1	1	1	1	0	0	0	0	0	0
	Blue	0	0	0	0	0	0	0	0	0	0	0	0	1	1	1	1	1	1
	Cyan	0	0	0	0	0	0	1	1	1	1	1	1	1	1	1	1	1	1
	Magenta	1	1	1	1	1	1	0	0	0	0	0	0	1	1	1	1	1	1
	Yellow	1	1	1	1	1	1	1	1	1	1	1	1	0	0	0	0	0	0
	White	1	1	1	1	1	1	1	1	1	1	1	1	1	1	1	1	1	1
RED	RED (00)	0	0	0	0	0	0	0	0	0	0	0	0	0	0	0	0	0	0
	RED (01)	0	0	0	0	0	1	0	0	0	0	0	0	0	0	0	0	0	0
					
	RED (62)	1	1	1	1	1	0	0	0	0	0	0	0	0	0	0	0	0	0
	RED (63)	1	1	1	1	1	1	0	0	0	0	0	0	0	0	0	0	0	0
GREEN	GREEN (00)	0	0	0	0	0	0	0	0	0	0	0	0	0	0	0	0	0	0
	GREEN (01)	0	0	0	0	0	0	0	0	0	0	0	1	0	0	0	0	0	0
					
	GREEN (62)	0	0	0	0	0	0	1	1	1	1	1	0	0	0	0	0	0	0
	GREEN (63)	0	0	0	0	0	0	1	1	1	1	1	1	0	0	0	0	0	0
BLUE	BLUE (00)	0	0	0	0	0	0	0	0	0	0	0	0	0	0	0	0	0	0
	BLUE (01)	0	0	0	0	0	0	0	0	0	0	0	0	0	0	0	0	0	1
					
	BLUE (62)	0	0	0	0	0	0	0	0	0	0	0	0	1	1	1	1	1	0
	BLUE (63)	0	0	0	0	0	0	0	0	0	0	0	0	1	1	1	1	1	1

Note : This document is preliminary version. The latest version must be checked from LG.Philips LCD before detail design.

Product Specification

3-7. Power Sequence

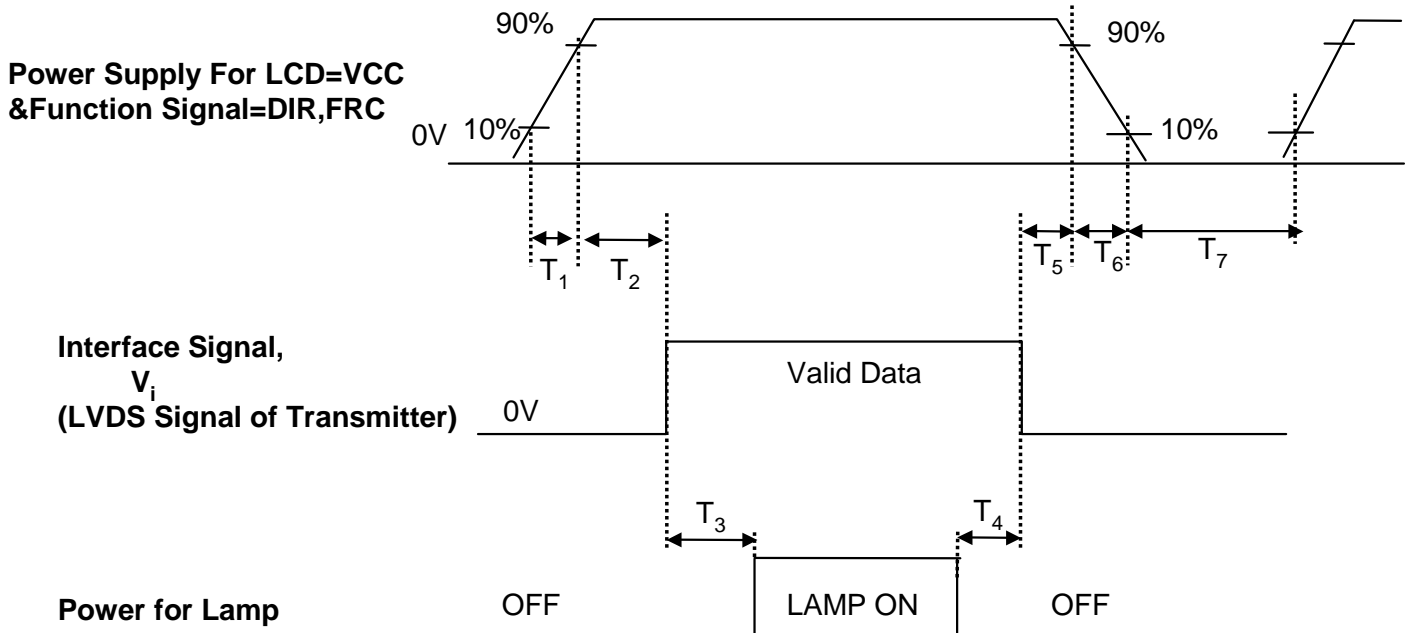

Table 9. POWER SEQUENCE TABLE

Parameter	Value			Units
	Min.	Typ.	Max.	
T ₁	-	-	10	(ms)
T ₂	0	-	50	(ms)
T ₃	200	-	-	(ms)
T ₄	200	-	-	(ms)
T ₅	0	-	50	(ms)
T ₆	-	-	10	(ms)
T ₇	400	-	-	(ms)

Notes:

1. Please avoid floating state of interface signal at invalid period.
2. When the interface signal is invalid, be sure to pull down the power supply for LCD VCC to 0V.
3. Lamp power must be turn on after power supply for LCD and interface signal are valid.

Product Specification

3-8. Scanning Directions

LB084S01 can change scanning direction by DIR input condition. See the Table 10 and FIG.3.

Table 10 . Scanning direction and DIR Input

Scanning direction	DIR input	Note
Normal	Low	-
Reverse	High	-

Normal and reverse scan direction are shown in the FIG.3. The figures are seen from a front view and the arrow is the direction of scan.

FIG.3 Scanning direction

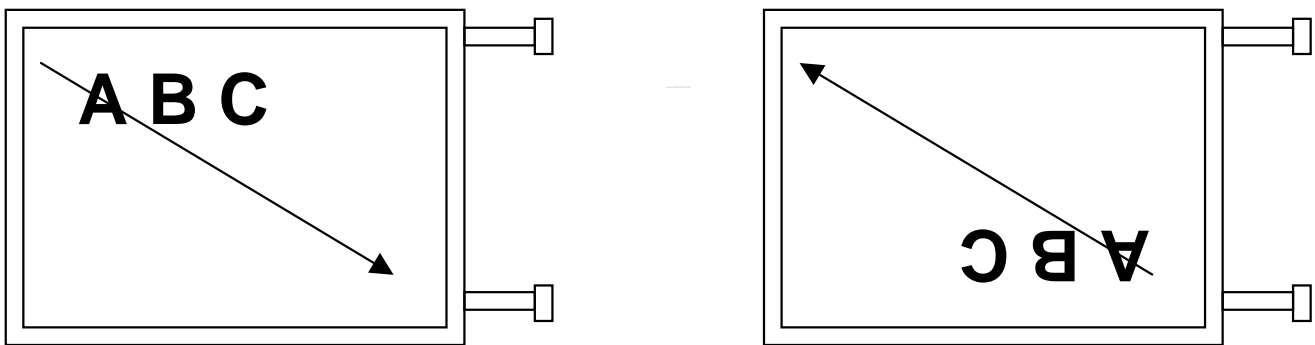

[Normal scan]

[Reverse scan]

Product Specification

4. Optical Specification

Optical characteristics are determined after the unit has been 'ON' and stable for approximately 30 minutes in a dark environment at 25°C. The values specified are at an approximate distance 50cm from the LCD surface at a viewing angle of Φ and Θ equal to 0°.

FIG. 4 presents additional information concerning the measurement equipment and method.

FIG. 4 Optical Characteristic Measurement Equipment and Method

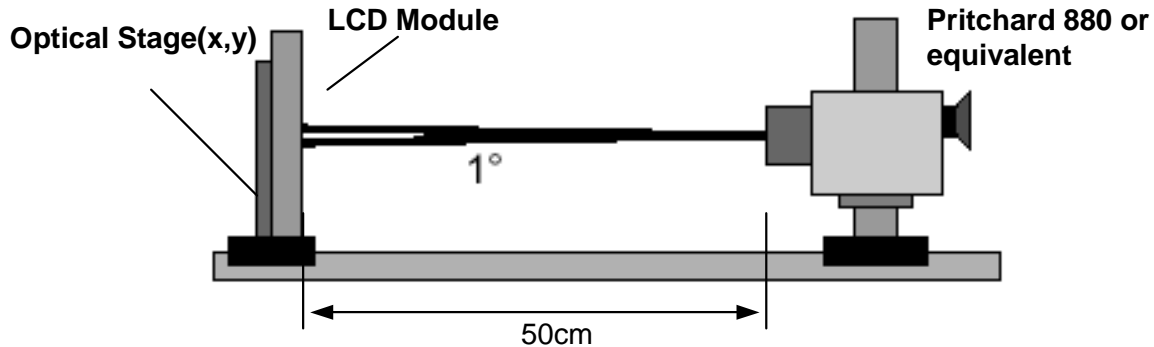

Table 11. OPTICAL CHARACTERISTICS

Measurement condition : $T_a=25^\circ\text{C}$, $V_{CC}=3.3\text{V}$, $DIR=Low$, $SVGA$, $f_V=60\text{Hz}$, $f_{CLK}=38.5\text{MHz}$, $I_{BL}=7\text{mA}$

Parameter	Symbol	Values			Units	Notes
		Min	Typ	Max		
Contrast Ratio	CR	-	600	-		1
Surface Luminance, white	L_{WH}	480	600	-	cd/m ²	2
Luminance Variation	δ_{WHITE}		1.25	1.40		3
Response Time						4
Rise Time	T_{rR}	-	7	15	ms	
Delay Time	T_{rD}	-	18	30	ms	
Color Coordinates						
RED	RX	TBD	TBD	TBD		Reference
RED	RY	TBD	TBD	TBD		Reference
GREEN	GX	TBD	TBD	TBD		Reference
GREEN	GY	TBD	TBD	TBD		Reference
BLUE	BX	TBD	TBD	TBD		Reference
BLUE	BY	TBD	TBD	TBD		Reference
WHITE	WX	0.283	0.313	0.343		
WHITE	WY	0.299	0.329	0.359		
Viewing Angle						5
x axis, right ($\Phi=0^\circ$)	Θ_r	70	75	-	degree	
x axis, left ($\Phi=180^\circ$)	Θ_l	70	75	-	degree	
y axis, up ($\Phi=90^\circ$)	Θ_u	60	65	-	degree	
y axis, down ($\Phi=270^\circ$)	Θ_d	50	55	-	degree	

Notes : If don't satisfied measurement condition, measurement value may be out of optical specification.

Product Specification

Notes:

1. Contrast Ratio(CR) is defined mathematically as

$$\text{Contrast Ratio} = \frac{\text{Surface Luminance with all white pixels}}{\text{Surface Luminance with all black pixels}}$$

2. Surface luminance is the center point across the LCD surface 50cm from the surface with all pixels displaying white. For more information see FIG 5.

$$L_{WH} = L_1$$

3. The variation in surface luminance , The panel total variation (δ_{WHITE}) is determined by measuring L_N at each test position 1 through 5 and then defined as followed numerical formula.
For more information see FIG 5.

$$\delta_{WHITE} = \frac{\text{Maximum } (L_1, L_2, \dots L_5)}{\text{Minimum } (L_1, L_2, \dots L_5)}$$

4. Response time is the time required for the display to transition from white to black (rise time, Tr_R) and from black to white(Decay Time, Tr_D). For additional information see FIG 6.
5. Viewing angle is the angle at which the contrast ratio is greater than 10. The angles are determined for the horizontal or x axis and the vertical or y axis with respect to the z axis which is normal to the LCD surface. For more information see FIG 7.

Product Specification

FIG. 5 Luminance

<measuring point for surface luminance>

<measuring point for luminance variation>

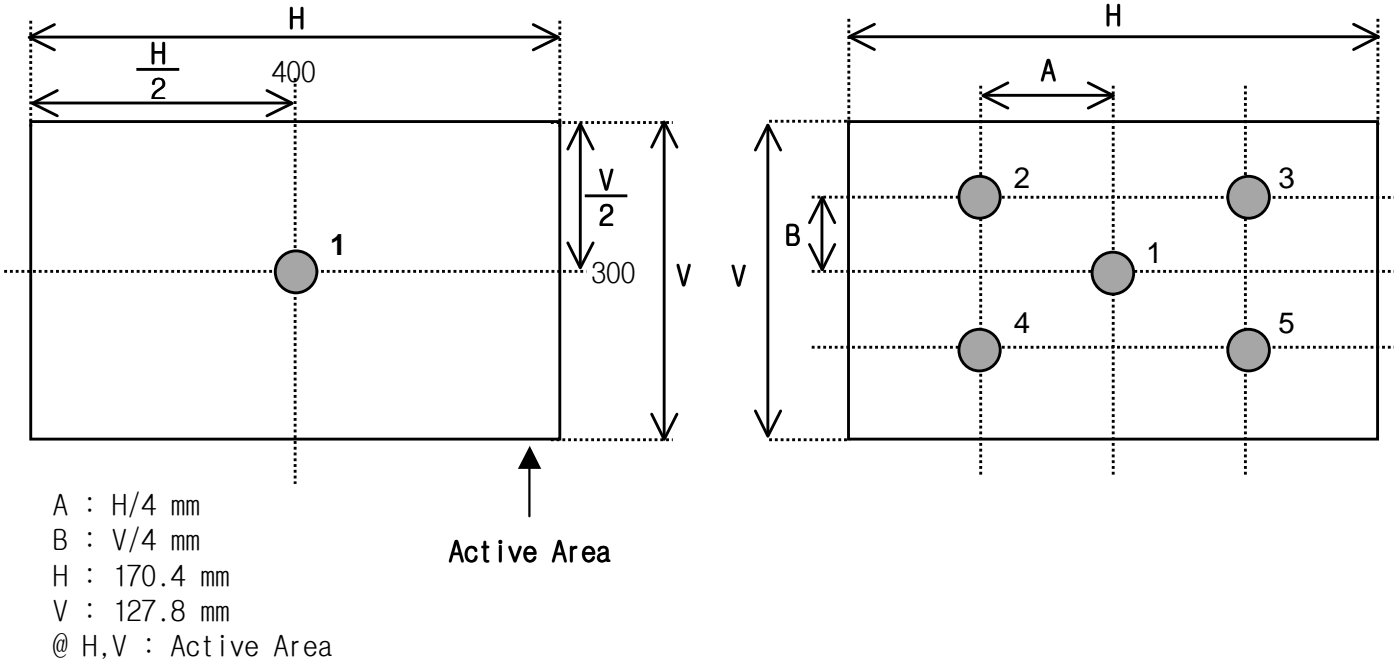
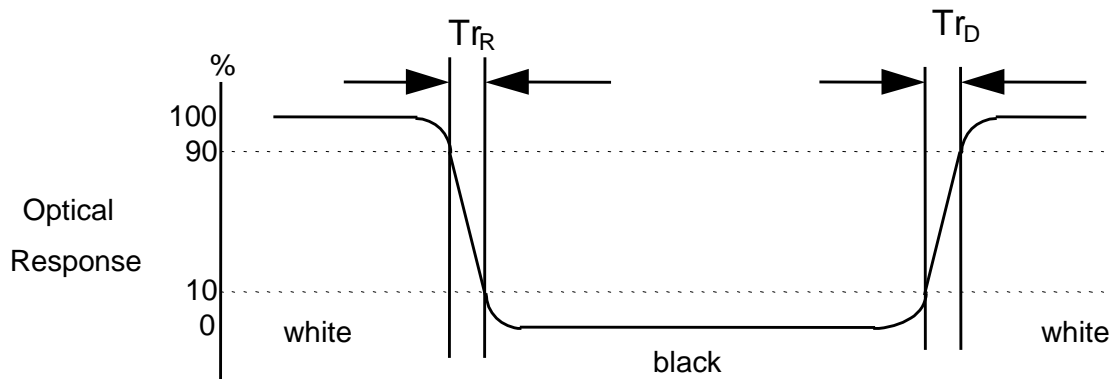

FIG. 6 Response Time

The response time is defined as the following figure and shall be measured by switching the input signal for "black" and "white".



Product Specification

FIG. 7 Viewing angle

<Dimension of viewing angle range>

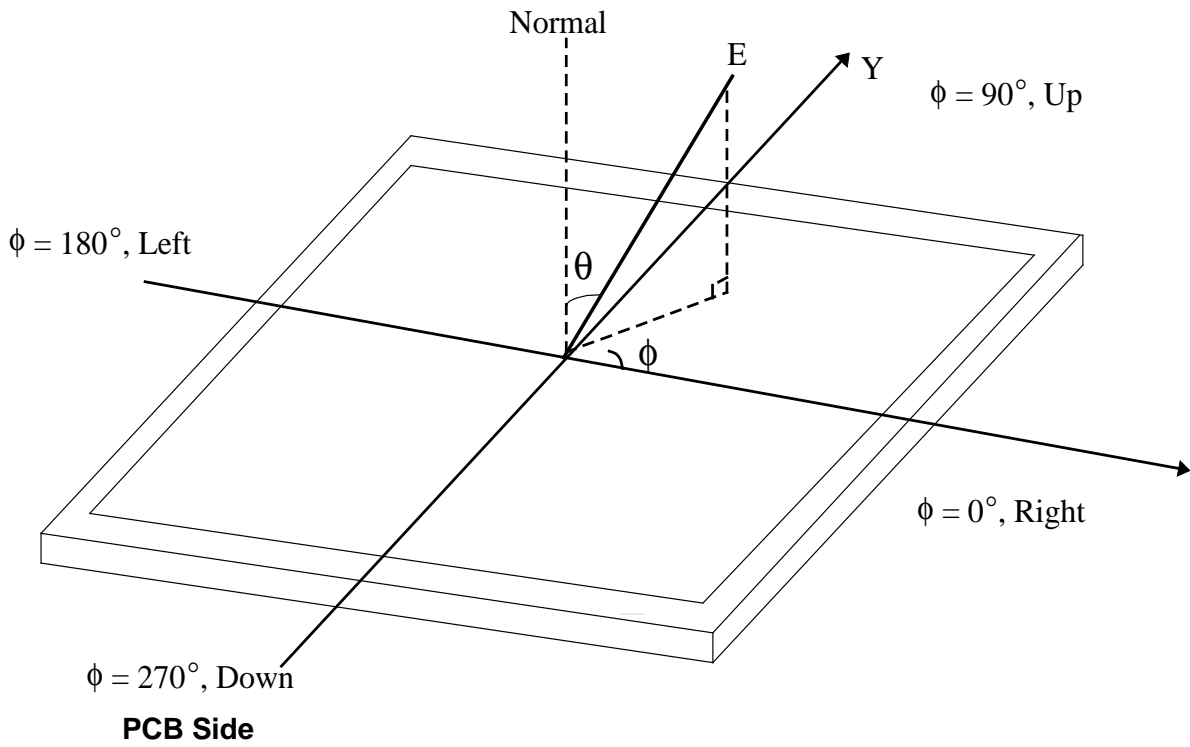

Note : This document is preliminary version. The latest version must be checked from LG.Philips LCD before detail design.

Product Specification

5. Mechanical Characteristics

The contents provide general mechanical characteristics for the model LB084S01. In addition the figures in the next page are detailed mechanical drawing of the LCD.

Outline Dimension	Horizontal	189.5 ± 0.5mm
	Vertical	148.6 ± 0.5mm
	Depth	9.1 ± 0.5mm
Bezel Area	Horizontal	173 ± 0.5mm
	Vertical	130.6 ± 0.5mm
Active Display Area	Horizontal	170.4 mm
	Vertical	127.8 mm
Weight	320 g (Typ.) 330 g (Max.)	

Product Specification

<FRONT VIEW>

Note) Unit:[mm], General tolerance: ± 0.5 mm

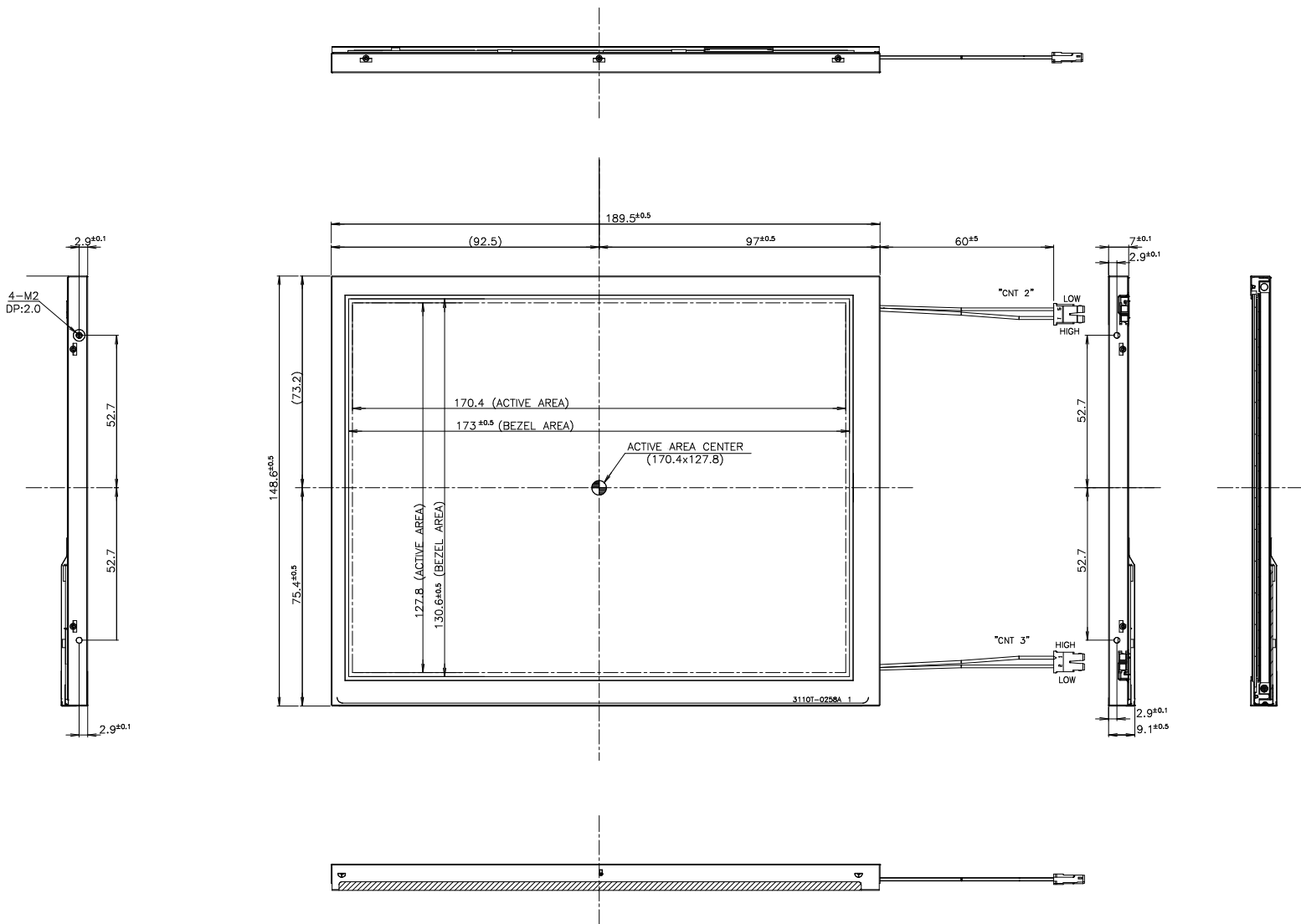

Product Specification

<REAR VIEW>

Note) Unit:[mm], General tolerance: ± 0.5mm

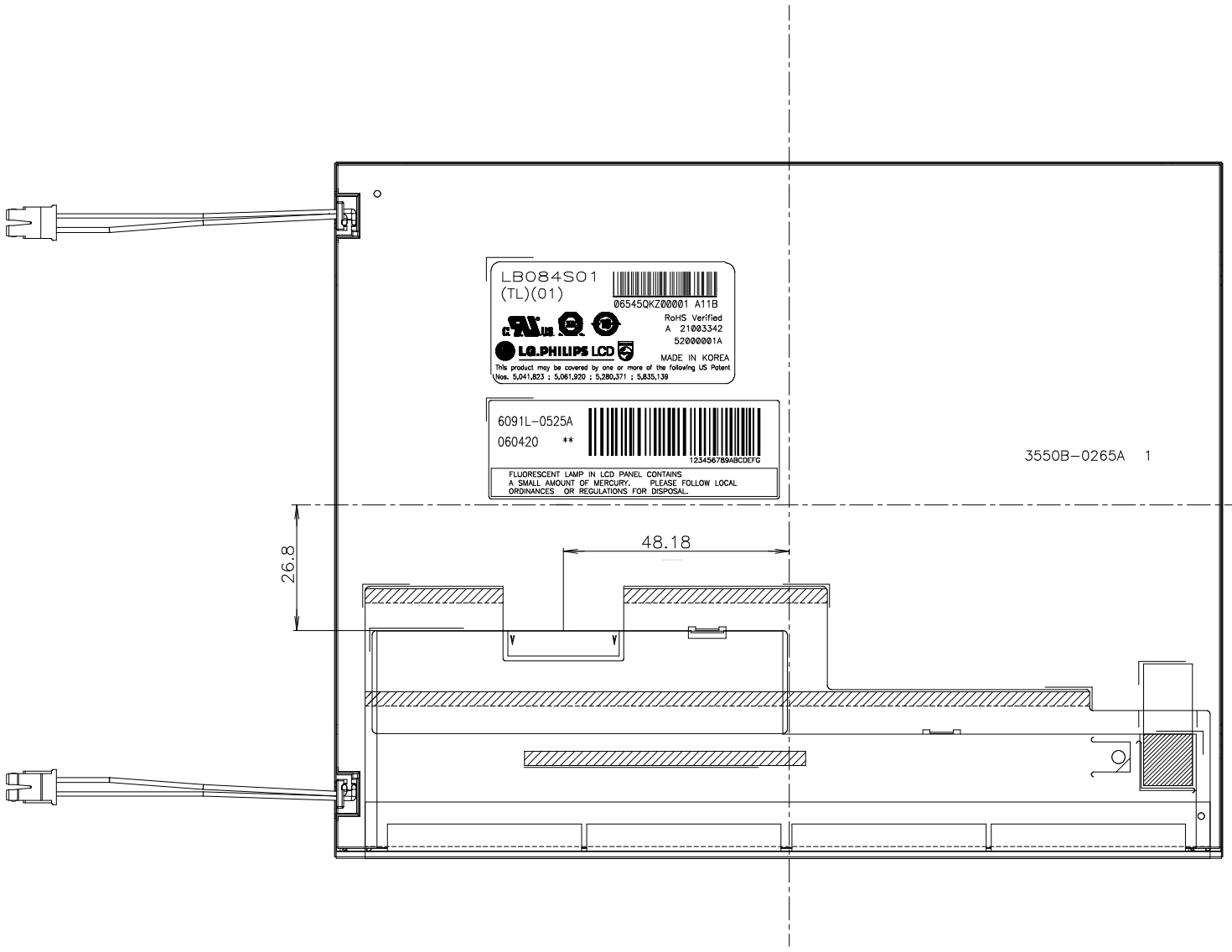

Note : This document is preliminary version. The latest version must be checked from LG.Philips LCD before detail design.

Product Specification

[DETAIL DESCRIPTION OF SIDE MOUNTING SCREW]

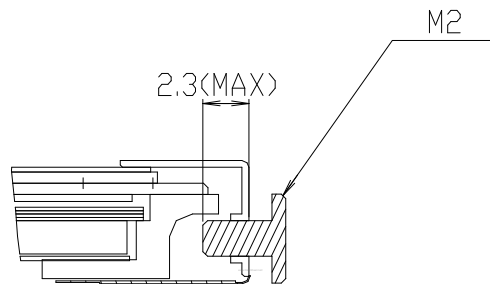

- *MOUNTING SCREW DEPTH : MAX 2.3mm
- *SCREW(6ea) TORQUE : Max 2.5kgf*cm

Note) Unit:[mm], General tolerance: ± 0.5 mm

Product Specification

6. Reliability

Environment test condition

No.	Test Item	Conditions
1	High temperature storage test	Ta= 80°C, 240h
2	Low temperature storage test	Ta= -20°C, 240h
3	High temperature operation test	Ta= 70°C, 240h
4	Low temperature operation test	Ta= -10°C, 240h
5	High Temp. High Humidity	Ta= 60°C, 90%RH, 240h
6	Thermal shock	-20°C, 30minute 80°C, 30minute 100cycle, 1hour / cycle
7	Vibration test (non-operating)	Random, 10~300Hz,0.0035~0.0035G/Hz 1.0Grms, 1 axis, 0.5hour/axis
8	Shock test (non-operating)	Half sine wave, 180G, 2ms One shock of each three faces (I.e. run 180G 6ms For all one faces)
9	Altitude operating storage / shipment	0 - 10,000 feet(3,048m) 24Hr 0 - 40,000 feet(12,192m) 24Hr

[Result Evaluation Criteria]

There should be no change which might affect the practical display function when the display quality test is conducted under normal operating condition.

Product Specification**7. International Standards****7-1. Safety**

- a) UL 60950-1:2003, First Edition, Underwriters Laboratories, Inc., Standard for Safety of Information Technology Equipment.
- b) CAN/CSA C22.2, No. 60950-1-03 1st Ed. April 1, 2003, Canadian Standards Association, Standard for Safety of Information Technology Equipment.
- c) EN 60950-1:2001, First Edition, European Committee for Electrotechnical Standardization(CENELEC) European Standard for Safety of Information Technology Equipment.

7-2. EMC

- a) ANSI C63.4 "Methods of Measurement of Radio-Noise Emissions from Low-Voltage Electrical and Electrical Equipment in the Range of 9kHz to 40GHz. "American National Standards Institute(ANSI), 1992
- b) C.I.S.P.R. "Limits and Methods of Measurement of Radio Interface Characteristics of Information Technology Equipment." International Special Committee on Radio Interference.
- c) EN 55022 "Limits and Methods of Measurement of Radio Interface Characteristics of Information Technology Equipment." European Committee for Electrotechnical Standardization.(CENELEC), 1998 (Including A1: 2000)

Product Specification

8. Packing

8-1. Designation of Lot Mark

a) Lot Mark

A	B	C	D	E	F	G	H	I	J	K	L	M
---	---	---	---	---	---	---	---	---	---	---	---	---

A,B,C : SIZE(INCH)
E : MONTH

D : YEAR
F ~ M : SERIAL NO.

Note

1. YEAR

Year	2001	2002	2003	2004	2005	2006	2007	2008	2009	2010
Mark	1	2	3	4	5	6	7	8	9	0

2. MONTH

Month	Jan	Feb	Mar	Apr	May	Jun	Jul	Aug	Sep	Oct	Nov	Dec
Mark	1	2	3	4	5	6	7	8	9	A	B	C

b) Location of Lot Mark

Serial No. is printed on the label. The label is attached to the backside of the LCD module.
This is subject to change without prior notice.

Product Specification

8-2. Packing Form

- a) Package quantity in one box : 26 pcs
- b) Box Size : 331x284x474

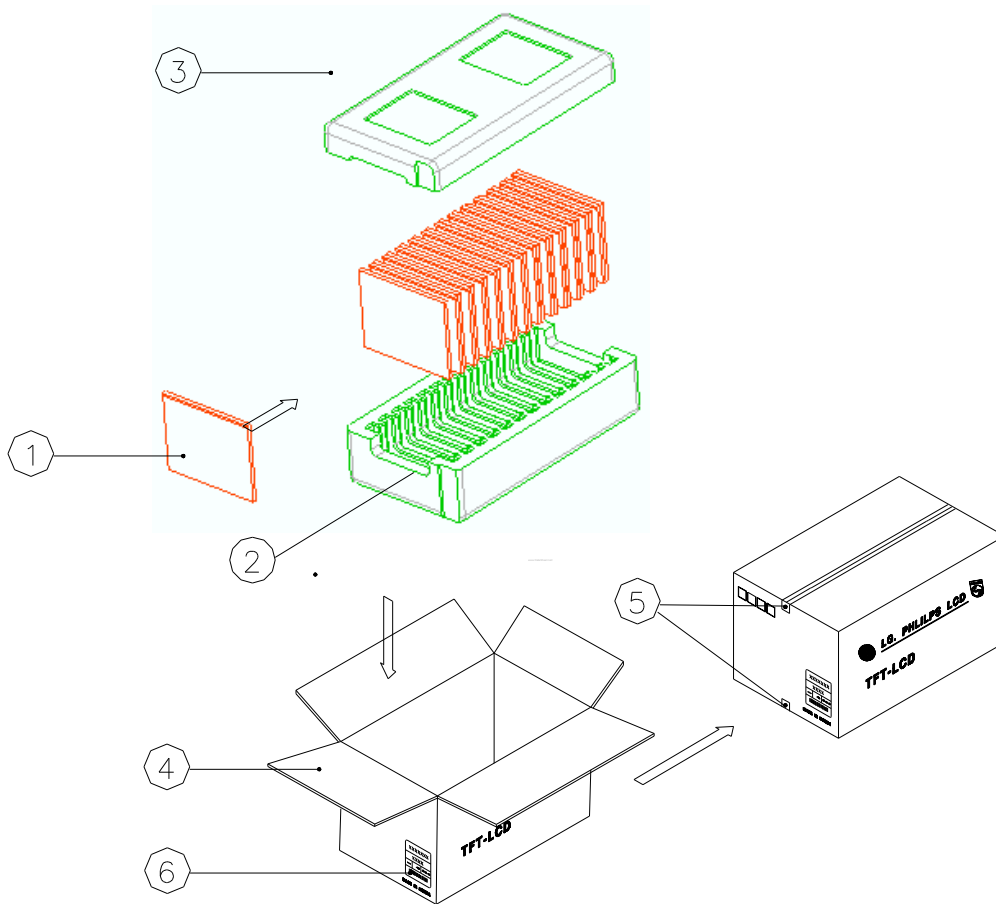

NO.	Description	Material
1	Module	
2	Packing, Bottom	EPS
3	Packing, Top	EPS
4	Carton Box	SWR4
5	Tape	OPP 70MMx300m
6	Label	YUPO Paper 100x100

Product Specification**9. PRECAUTIONS**

Please pay attention to the followings when you use this TFT LCD module.

9-1. MOUNTING PRECAUTIONS

- (1) You must mount a module using holes arranged in four corners or four sides.
- (2) You should consider the mounting structure so that uneven force (ex. Twisted stress) is not applied to the module. And the case on which a module is mounted should have sufficient strength so that external force is not transmitted directly to the module.
- (3) Please attach the surface transparent protective plate to the surface in order to protect the polarizer. Transparent protective plate should have sufficient strength in order to resist external force.
- (4) You should adopt radiation structure to satisfy the temperature specification.
- (5) Acetic acid type and chlorine type materials for the cover case are not desirable because the former generates corrosive gas of attacking the polarizer at high temperature and the latter causes circuit break by electro-chemical reaction.
- (6) Do not touch, push or rub the exposed polarizers with glass, tweezers or anything harder than HB pencil lead. And please do not rub with dust clothes with chemical treatment. Do not touch the surface of polarizer for bare hand or greasy cloth. (Some cosmetics are detrimental to the polarizer.)
- (7) When the surface becomes dusty, please wipe gently with absorbent cotton or other soft materials like chamois soaked with petroleum benzene. Normal-hexane is recommended for cleaning the adhesives used to attach front / rear polarizers. Do not use acetone, toluene and alcohol because they cause chemical damage to the polarizer.
- (8) Wipe off saliva or water drops as soon as possible. Their long time contact with polarizer causes deformations and color fading.
- (9) Do not open the case because inside circuits do not have sufficient strength.

9-2. OPERATING PRECAUTIONS

- (1) The spike noise causes the mis-operation of circuits. It should be lower than following voltage :
 $V = \pm 200\text{mV}$ (Over and under shoot voltage)
- (2) Response time depends on the temperature. (In lower temperature, it becomes longer.)
- (3) Brightness depends on the temperature. (In lower temperature, it becomes lower.)
And in lower temperature, response time (required time that brightness is stable after turned on) becomes longer.
- (4) Be careful for condensation at sudden temperature change. Condensation makes damage to polarizer or electrical contacted parts. And after fading condensation, smear or spot will occur.
- (5) When fixed patterns are displayed for a long time, remnant image is likely to occur.
- (6) Module has high frequency circuits. Sufficient suppression to the electromagnetic interference shall be done by system manufacturers. Grounding and shielding methods may be important to minimize the interference.

Product Specification

9-3. ELECTROSTATIC DISCHARGE CONTROL

Since a module is composed of electronic circuits, it is not strong to electrostatic discharge. Make certain that treatment persons are connected to ground through wrist band etc. And don't touch interface pin directly.

9-4. PRECAUTIONS FOR STRONG LIGHT EXPOSURE

Strong light exposure causes degradation of polarizer and color filter.

9-5. STORAGE

When storing modules as spares for a long time, the following precautions are necessary.

- (1) Store them in a dark place. Do not expose the module to sunlight or fluorescent light. Keep the temperature between 5°C and 35°C at normal humidity.
- (2) The polarizer surface should not come in contact with any other object.
It is recommended that they be stored in the container in which they were shipped.

9-6. HANDLING PRECAUTIONS FOR PROTECTION FILM

- (1) When the protection film is peeled off, static electricity is generated between the film and polarizer. This should be peeled off slowly and carefully by people who are electrically grounded and with well ion-blown equipment or in such a condition, etc.
- (2) The protection film is attached to the polarizer with a small amount of glue. If some stress is applied to rub the protection film against the polarizer during the time you peel off the film, the glue is apt to remain on the polarizer.
Please carefully peel off the protection film without rubbing it against the polarizer.
- (3) When the module with protection film attached is stored for a long time, sometimes there remains a very small amount of glue still on the polarizer after the protection film is peeled off.
- (4) You can remove the glue easily. When the glue remains on the polarizer surface or its vestige is recognized, please wipe them off with absorbent cotton waste or other soft material like chamois soaked with normal-hexane.