

# Current Transducer LB 1000-SI/SP2

$$I_{PN} = 1000 \text{ A}$$

For the electronic measurement of currents : DC, AC, pulsed..., with a galvanic isolation between the primary circuit (high power) and the secondary circuit (electronic circuit).

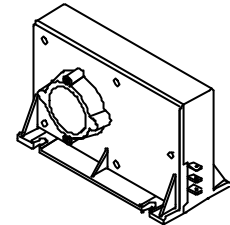

## Electrical data

$I_{PN}$	Primary nominal r.m.s. current	1000	A
$I_p$	Primary current, measuring range	0 .. $\pm 1500$	A
$R_M$	Measuring resistance with $\pm 15 \text{ V}$	$R_{M \min}$	$R_{M \max}$
		@ $\pm 1000 \text{ A}_{\max}$	0 25 $\Omega$
		@ $\pm 1500 \text{ A}_{\max}$	0 5 $\Omega$
$I_{SN}$	Secondary nominal r.m.s. current	200	m A
$K_N$	Conversion ratio	1 : 5000	
$V_C$	Supply voltage ( $\pm 5 \%$ )	$\pm 15$	V
$I_C$	Current consumption	$21 + I_s$	m A
$V_d$	R.m.s. voltage for AC isolation test, 50 Hz, 1 mn	6	k V

## Accuracy - Dynamic performance data

$X_G$	Overall accuracy @ $I_{PN}, T_A = 25^\circ\text{C}$	$\pm 0.3$	%
$e_L$	Linearity	$< 0.1$	%
$I_O$	Offset current @ $I_p = 0, T_A = 25^\circ\text{C}$	Typ	Max
$I_{OT}$	Thermal drift of $I_O$ + $10^\circ\text{C} \dots + 50^\circ\text{C}$	$\pm 0.1$	$\pm 0.2$ m A
$t_r$	Response time <sup>1)</sup> @ 90 % of $I_{p \max}$	$< 1$	$\mu\text{s}$
$di/dt$	di/dt accurately followed	$> 50$	A/ $\mu\text{s}$
$f$	Frequency bandwidth (-1 dB)	DC .. 100	k Hz

## General data

$T_A$	Ambient operating temperature	+ 10 .. + 50	$^\circ\text{C}$
$T_S$	Ambient storage temperature	- 25 .. + 85	$^\circ\text{C}$
$R_S$	Secondary coil resistance @ $T_A = 70^\circ\text{C}$	40	$\Omega$
$m$	Mass	700	g
	Standards <sup>2)</sup>	EN 50178	

## Features

- Closed loop (compensated) current transducer using the Hall effect
- Insulated plastic case recognized according to UL 94-V0.

## Special features

- Better zero crossing performance
- $T_A = +10^\circ\text{C} \dots + 50^\circ\text{C}$
- Shield between primary and secondary.

## Advantages

- Excellent accuracy
- Very good linearity
- Low temperature drift
- Optimized response time
- Wide frequency bandwidth
- No insertion losses
- High immunity to external interference
- Current overload capability.

## Applications

- AC variable speed drives and servo motor drives
- Static converters for DC motor drives
- Battery supplied applications
- Uninterruptible Power Supplies (UPS)
- Switched Mode Power Supplies (SMPS)
- Power supplies for welding applications.

Notes : <sup>1)</sup> With a di/dt of 100 A/ $\mu\text{s}$

<sup>2)</sup> A list of corresponding tests is available

000901/0

## Dimensions LB 1000-SI/SP2 (in mm. 1 mm = 0.0394 inch)

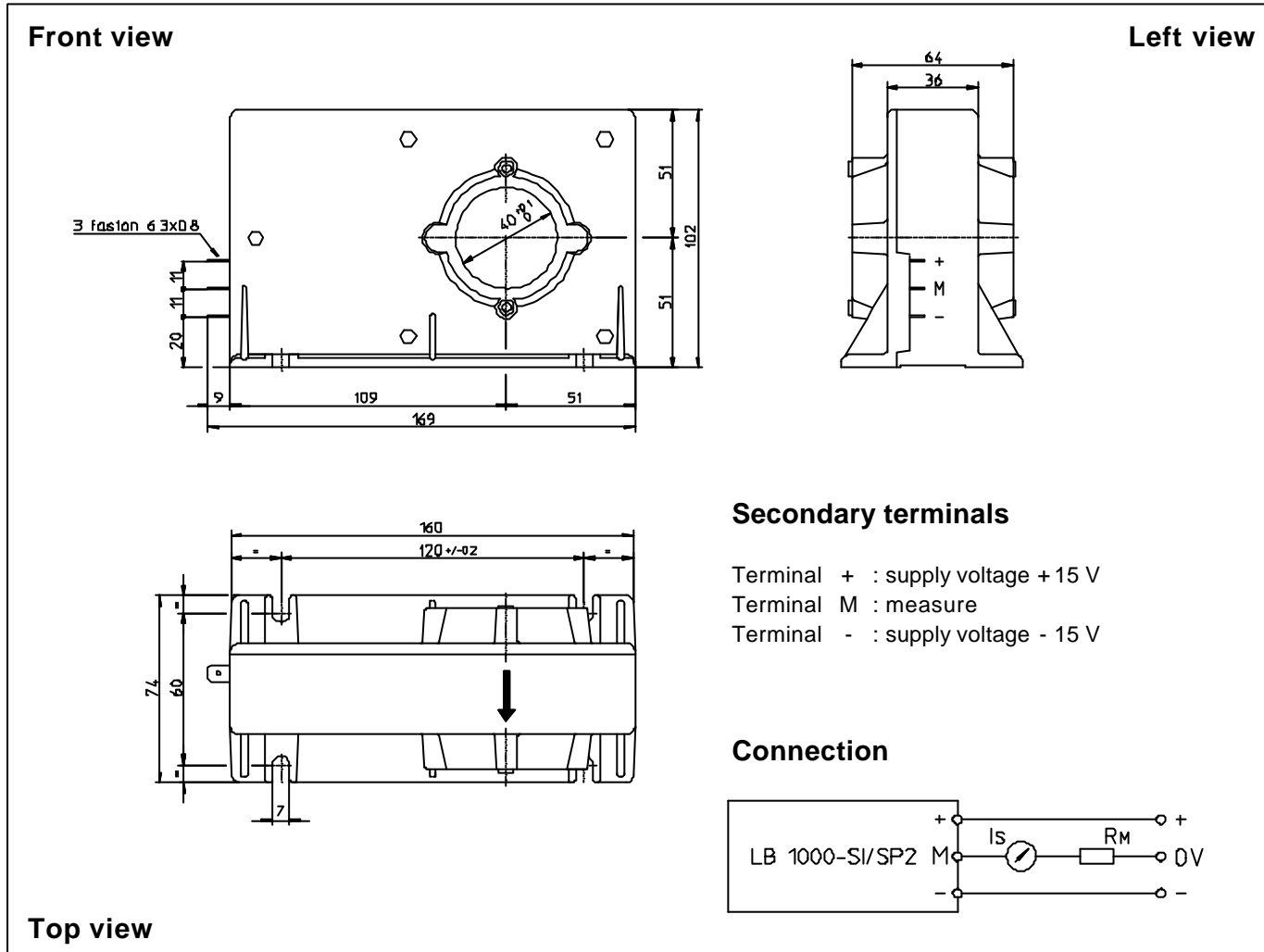

### Mechanical characteristics

- General tolerance ± 0.5 mm
- Fastening 4 slots Ø 7 mm
- Primary through-hole Ø 40 mm
- Connection of secondary Faston 6.3 x 0.8 mm.

### Remarks

- $I_s$  is positive when  $I_p$  flows in the direction of the arrow.
- Temperature of the primary conductor should not exceed 100°C.
- Dynamic performances (di/dt and response time) are best with a single bar completely filling the primary hole.