

**Product Specification**

# SPECIFICATION FOR APPROVAL

- ( ) Preliminary Specification  
( ) Final Specification

<b>Title</b>	<b>10.2”W (800 X RGB X 480) TFT - LCD</b>
--------------	---

BUYER	
MODEL	

SUPPLIER	LG.Philips LCD Co., Ltd.
MODEL	LB102WV1
SUFFIX	TJ01

SIGNATURE	DATE
_____/_____  	_____  
_____/_____  	_____  
_____/_____  	_____  

Please return 1copy for your confirmation with  
Your signature and comment

APPROVED BY	DATE
C.S. KYEONG /S.Manager _____ <b>REVIEWED BY</b>	_____  
S.G. KIM /Engineer _____ <b>PREPARED BY</b>	_____  
A.R.CHO / Engineer _____  	_____  

**Product Engineering Dept.  
LG. Philips LCD Co., Ltd**

**Product Specification****CONTENTS**

NO	ITEM	PAGE
0	Record of Revisions	3
1	Summary	4
2	Features	4
3	General Specification	5
4	Interface (Input Terminal)	6
5	Absolute Maximum Ratings	8
6	Electrical Characteristics	9
7	Electro-optical Characteristics	16
8	Mechanical Characteristics	18
9	Reliability Test	20
10	Packing	21
11	Precautions	23



**Product Specification**

**1. Summary**

The LB102WV1-TJ01 is a **Board Assembly** Product of TFT LCD without any extra system. This module utilizes amorphous silicon thin film transistors and a 15:9 aspect ratio. A 10.2" active matrix liquid crystal display allows 262,144 colors to be displayed. The applications are portable DVD, multimedia applications and others AV system.

**2. Features**

- Utilizes a panel with a 15:9 aspect ratio suitable for use in wide-screen systems.
- The 10.2" screen produces a high resolution image composed of 384,000 pixel in a stripe arrangement.
- Wide viewing angle technology is employed. The most suitable viewing direction is in the 6 o'clock.
- By adopting an active matrix drive, a picture with high contrast is realized.
- A thin, light and compact module is accomplished through the use of COG mounting technology.
- By adopting a high aperture panel, high transmittance color filter and high transmission polarizing plates, transmittance ratio is realized.
- This module is compatible with the Timing controller, developed by LG.Philips LCD.  
 [ T-con Model Name : Firebird, Part Number : 0IHYL-0070A ]

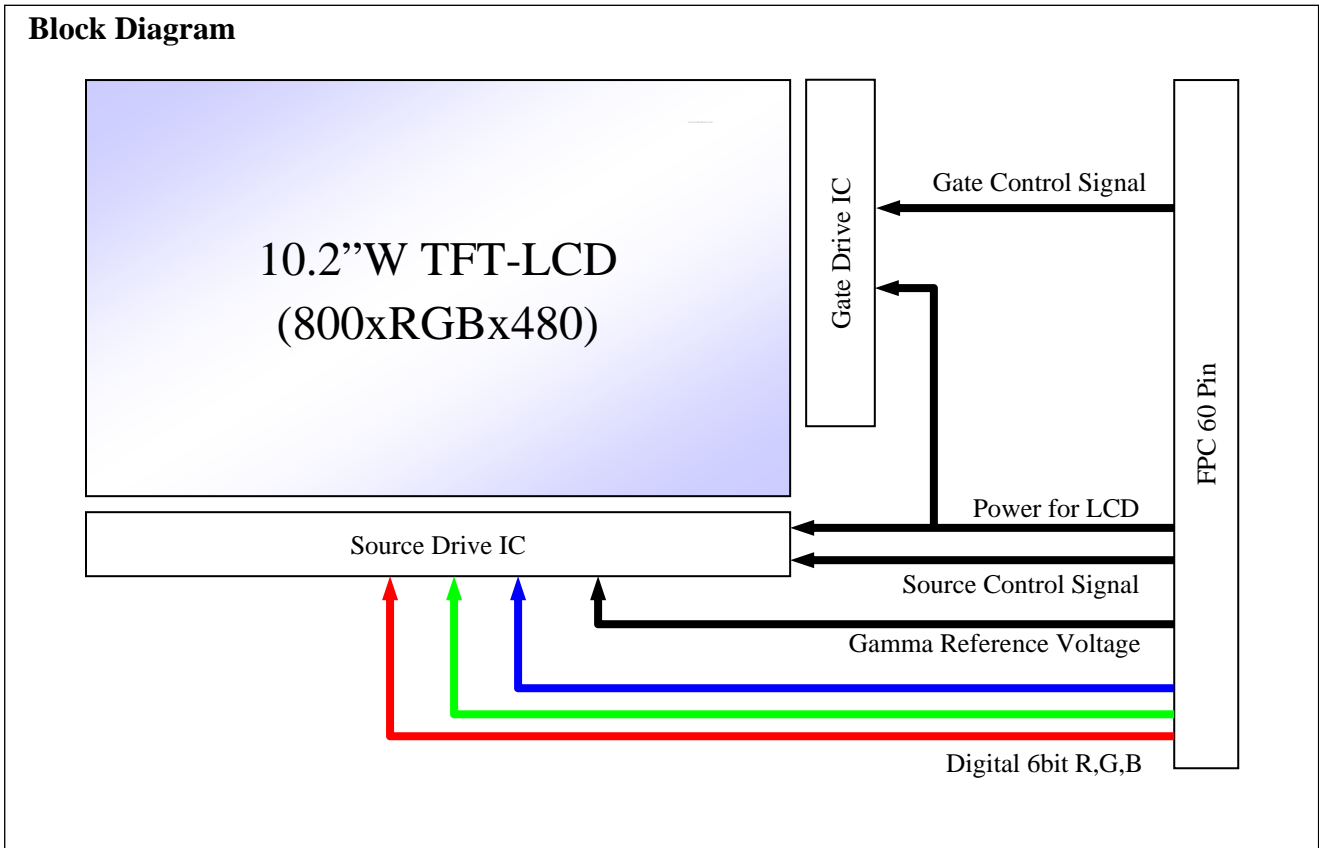

**Product Specification**

**3. General Specification**

Characteristic Item	Specification
Signal Interface	Digital Interface (CMOS)
Display Technology	a-Si TFT active matrix
Display Mode	Normally White, Transmitting Type
Screen Size (Diagonal)	10.2" (25.89cm)
Outline Dimension	230.6mm (H) X 142.2mm (V) X 1.7mm (D)
Active Area	222mm (H) X 133.2mm (H)
Number Of dots	800(H) X 3(R,G,B) X 480(V)
Color depth	6 Bit, 262,144 colors
Pixel Pitch	0.2775 mm (H) × 0.2775 mm (V)
Color Filter Array	RGB vertical stripes
Weight	114.2g(Typ.)
Surface Treatment	Anti-Glare Treatment

**Product Specification**

**4. Interface (Input Terminal)**

1> TFT-LCD Panel Driving Part

Pin	Symbol	Description	Notes
1	GND	Ground	
2	GND	Ground	
3	VGH	Gate Driver Positive Voltage	
4	VGL	Gate Driver Negative Voltage	
5	GVCC	Power Line For Gate Driver IC Logic	
6	GSP1	Gate Scanning Start Signal 1	
7	GSP2	Gate Scanning Start Signal 2	
8	GSC	Gate Driver Scanning Clock Pulse	
9	U_D	Up/Down Scanning Change	
10	GOE	Gate Driver Output Enable Control	
11	VCOM	Voltage Applied To Color Filter Substrate	
12	VCOM	Voltage Applied To Color Filter Substrate	
13	VCOM	Voltage Applied To Color Filter Substrate	
14	VDD	Power Line For Source Driver IC	
15	VDD	Power Line For Source Driver IC	
16	VREF5	Voltage For Gamma Correction	
17	VREF4	Voltage For Gamma Correction	
18	VREF3	Voltage For Gamma Correction	
19	VREF2	Voltage For Gamma Correction	
20	VREF1	Voltage For Gamma Correction	
21	VREF0	Voltage For Gamma Correction	
22	GND	Ground	
23	GND	Ground	
24	GND	Ground	
25	GND	Ground	
26	VCC	Power Line For Logic	
27	VCC	Power Line For Logic	
28	VCC	Power Line For Logic	
29	SSP2	Source Scanning Left Start Signal	
30	SSP1	Source Scanning Right Start Signal	

**Product Specification**

Pin	Symbol	Description	Notes
31	SOE	Source Driver Output Enable Control	
32	SSC	Source Driver Clock Input	
33	POL	Polarity Reversal Signal	
34	GND	Ground	
35	GND	Ground	
36	R0	Red Data 0 [LSB]	
37	R1	Red Data 1	
38	R2	Red Data 2	
39	R3	Red Data 3	
40	R4	Red Data 4	
41	R5	Red Data 5 [MSB]	
42	GND	Ground	
43	G0	Green Data 0 [LSB]	
44	G1	Green Data 1	
45	G2	Green Data 2	
46	G3	Green Data 3	
47	G4	Green Data 4	
48	G5	Green Data 5 [MSB]	
49	GND	Ground	
50	B0	Blue Data 0 [LSB]	
51	B1	Blue Data 1	
52	B2	Blue Data 2	
53	B3	Blue Data 3	
54	B4	Blue Data 4	
55	B5	Blue Data 5 [MSB]	
56	GND	Ground	
57	REV	Reverse of Input R,G,B Data Code	
58	L_R	Left/Right Scanning Change	
59	VCOM	Voltage Applied To Color Filter Substrate	
60	VCOM	Voltage Applied To Color Filter Substrate	

\* Input connector for the operation : GF05A-60S-AF manufactured by LS Cable or equivalent.

**Product Specification**

**5. Absolute Maximum Ratings**

The followings are maximum values which, if exceeded, may cause faulty operation or damage to the unit.

Parameter	Symbol	Condition	Min	Max	Unit	Notes
Logic Voltage	VCC	$T_a=25$	-0.5	4.0	V	
Source Driver Voltage	VDD	$T_a=25$	-0.3	14.5	V	
Digital Input Signals	$V_{I1}$	$T_a=25$	-0.5	VCC+0.5	V	[Note 5-1]
Analog Input Signals	$V_{I2}$	$T_a=25$	-0.5	VDD+0.5	V	[Note 5-2]
Gate Driver Voltage	VGH	$T_a=25$	-0.3	40	V	
	VGL	$T_a=25$	-20	0.3	V	
	VGH-VGL	$T_a=25$	-0.3	40	V	
	GVCC	$T_a=25$	-0.3	4	V	
Operating Temperature ( Ambient Temperature )	$T_{op}$	-	-10	60		[Note 5-3,4,5,6]
Storage Temperature	$T_{st}$	-	-20	70		[Note 5-3,4]

[Note 5-1] U\_D,GSP1/2,GSC,GOE, SSP1/2, SOE, SSC, POL, REV, L\_R, R0-5/G0-5/B0-5

[Note 5-2] VCOM,VREF0/1/2/3/4/5

[Note 5-3] This rating applies to all parts of the module and should not be exceeded.

[Note 5-4] Maximum wet-bulb temperature is 52 . Condensation of dew must be avoided as electrical current leaks will occur, causing a degradation of performance specifications.

[Note 5-5] The operating temperature only guarantees operation of the circuit and doesn't guarantee all the contents of Electro-optical specification.

[Note 5-6] Ambient temperature when the backlight is lit (reference value).

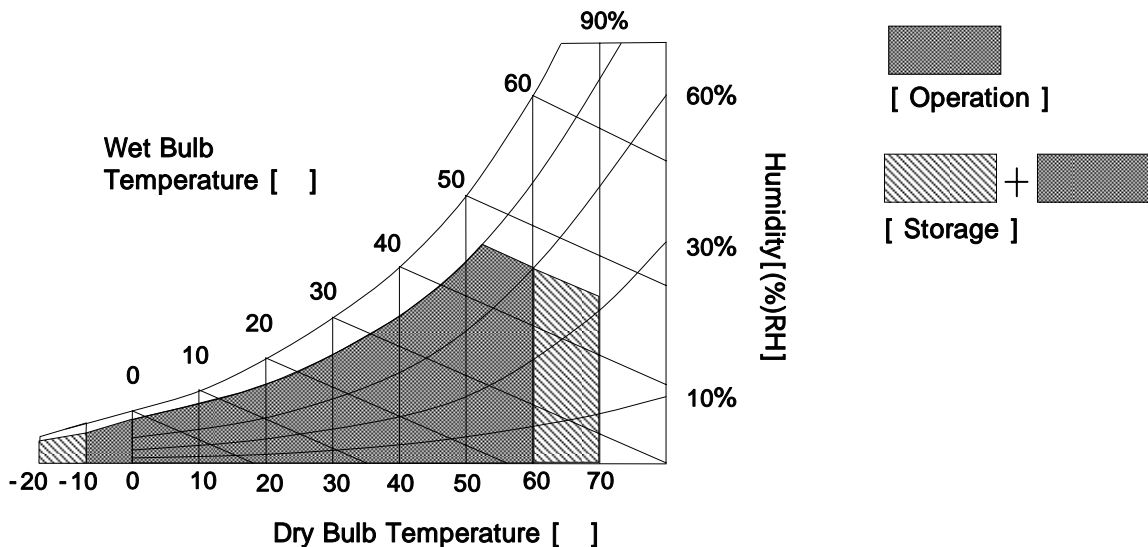



**Product Specification**
**6. Electrical Characteristics**
**1> Recommended Operating Conditions**

TFT-LCD Panel Driving Section

 $T_a=25$ 

Parameter		Symbol	Min	Typ	Max	Unit	Notes	
Logic Supply Voltage		VCC	3.0	3.3	3.6	V		
Digital Input Signal	High Level	$V_{IH}$	0.7VCC	-	VCC	V		
	Low Level	$V_{IL}$	0	-	0.3VCC	V		
Source Driver Supply Voltage		VDD	11.0	12.0	13.0	V		
Gate Driver	TFT	Hi	VGH	22	23	24	V	
		Lo	VGL	-8.8	-7.8	-6.8	V	
	Logic Supply Voltage	GVCC	3.0	3.3	3.6	V		
Gamma Correction Voltage	DC	VREF0~2	0.4VDD	-	VDD-0.2	V		
		VREF3~5	GND+0.2	-	0.6VDD			
Color Filter Substrate Voltage	DC	VCOM	4.8	5.0	5.2	V	With gate modulation [Note 6-1] [Note 6-2]	
			4.5	4.7	4.9	V	No gate modulation [Note 6-2]	
Source Driver Supply Current		IDD	-	29	45	mA	VDD = 12V	
Logic Supply Current		ICC	-	14	25	mA	VCC = 3.3V	
Gate Driver Logic Supply Current		GICC	-	0.01	0.2	mA	GVCC = 3.3V	
Gate Driver High Supply Current		IGH	-	0.4	0.7	mA	VGH = 23V	
Gate Driver Low Supply Current		IGL	-	0.5	0.8	mA	VGL = -7.8V	

\*\*\*\*\* Cautionary Matter : When applying or disconnecting power, please be sure that such action is sequentially carried out for all power supplies. In addition, apply input signals only after power has been turned on.

**[Power Sequence]**
**-Source Driver :**

Power on sequence : Case.1) VCC > Logic input > VDD > VREF0 to VREF5.  
 Case.2) VCC > VDD > VREF0 to VREF5 > Logic input.

Power off sequence is reverse turn of this.

**-Gate Driver :**

Power on sequence : GVCC > VGL > Input signal > VGH.  
 Power off sequence is reverse turn of this.

**Product Specification**

[Note 6-1]

This is VGH timing diagram when adopt gate modulation. You can use VGH(DC) or modulated VGH(AC) for TFT Hi voltage. Then you should design VCOM level proper.

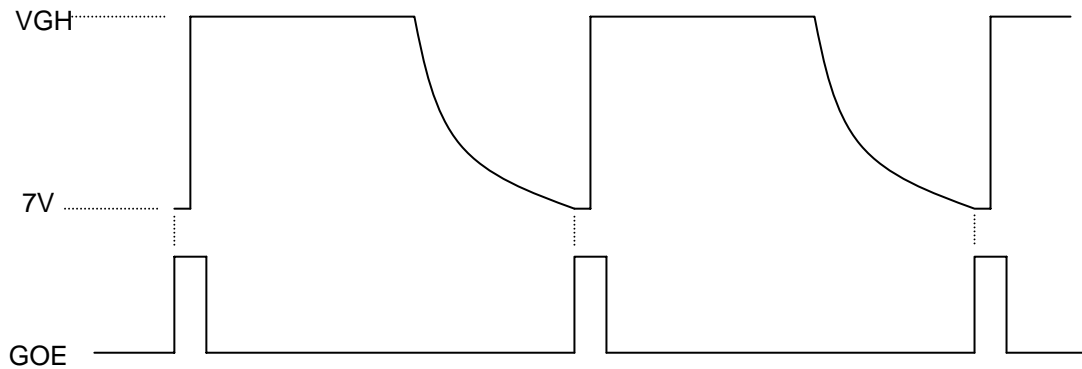

[Note 6-2]

We recommend to use buffer or OP-Amp for VCOM.

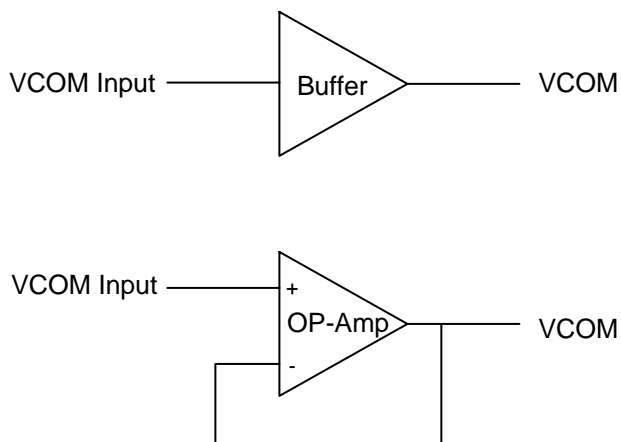

**Product Specification**
**2> Timing Characteristics of input signals**

Parameter		Symbol	Min	Typ	Max	Unit	Notes
<b>S O U R C E</b>	SSC Frequency	fclk	26	33.26	40	MHz	SSC
	High level SSC pulse width duration	twh	4	-	-	ns	
	Low level SSC pulse width duration	twl	4	-	-	ns	
	DATA/REV Setup Time	ts1	2	-	-	ns	DATA,REV
	DATA/REV Hold Time	th1	2	-	-	ns	
	Start Pulse Setup Time	ts2	3	-	-	ns	SSP1/2
	Start Pulse Hold Time	th2	3	-	-	ns	
	SOE Signal Setup Time	ts3	3	-	-	SSC cycle	SOE
	SOE Low Hold Time from final data SSC	th3	2	-	-	SSC cycle	
	High level SOE signal pulse width duration	twtp1	1	2.5	4	us	
	POL Signal SOE Setup Time	ts4	6	-	-	ns	SOE,POL
	POL Signal SOE Hold Time	th4	6	-	-	ns	
<b>G A T E</b>	GSC Frequency	fclk	24.7	31.5	37.8	KHz	[Note 1]
	GSC Rise Time	trck	-	-	100	ns	
	GSC Falling Time	tfck	-	-	100	ns	
	GSC Pulse Width	pwclk	500	-	-	ns	
	GSP1/2 Setup Time	tsu	200	-	-	ns	
	GSP1/2 Hold Time	thd	300	-	-	ns	
	GOE Pulse Width	twcl	1.5	2	4	us	

(Note 1) At least input one cycle of GSC during "L" period of GSP1.

**Product Specification**

**3> Detail Description of Pin Functions**

1. U\_D is used as input pin for selecting the shifting direction of bi-directional shift register.

U_D	Output Shift	GSP Input Pin
H	Down to Up	GSP1
L	Up to Down	GSP2

2. L\_R is used as input pin for the horizontal scanning direction. If L\_R is H, SSP1 is the Input Pin for the Source Start Pulse(SSP). Otherwise(If L\_R is L), SSP2 is the Input Pin for the Source Start Pulse.

L_R	Scanning Direction	SSP Input Pin
H	Form Left to Right	SSP1
L	From Right to Left	SSP2

**Product Specification**

**4> Recommended Gamma Correction Voltage [VREF0 to VREF5]**

Unit : Voltage

Symbol	Typ
VREF0	9.35
VREF1	7.6
VREF2	6
VREF3	5.03
VREF4	3.47
VREF5	1.71

(Note 1) Be sure to maintain the voltage relationships of  
 $VDD > VREF0 > VREF1 > VREF2 > VREF3 > VREF4 > VREF5 > GND$

**Product Specification**

**5> Timing Diagram**

Source D-IC Timing Diagram

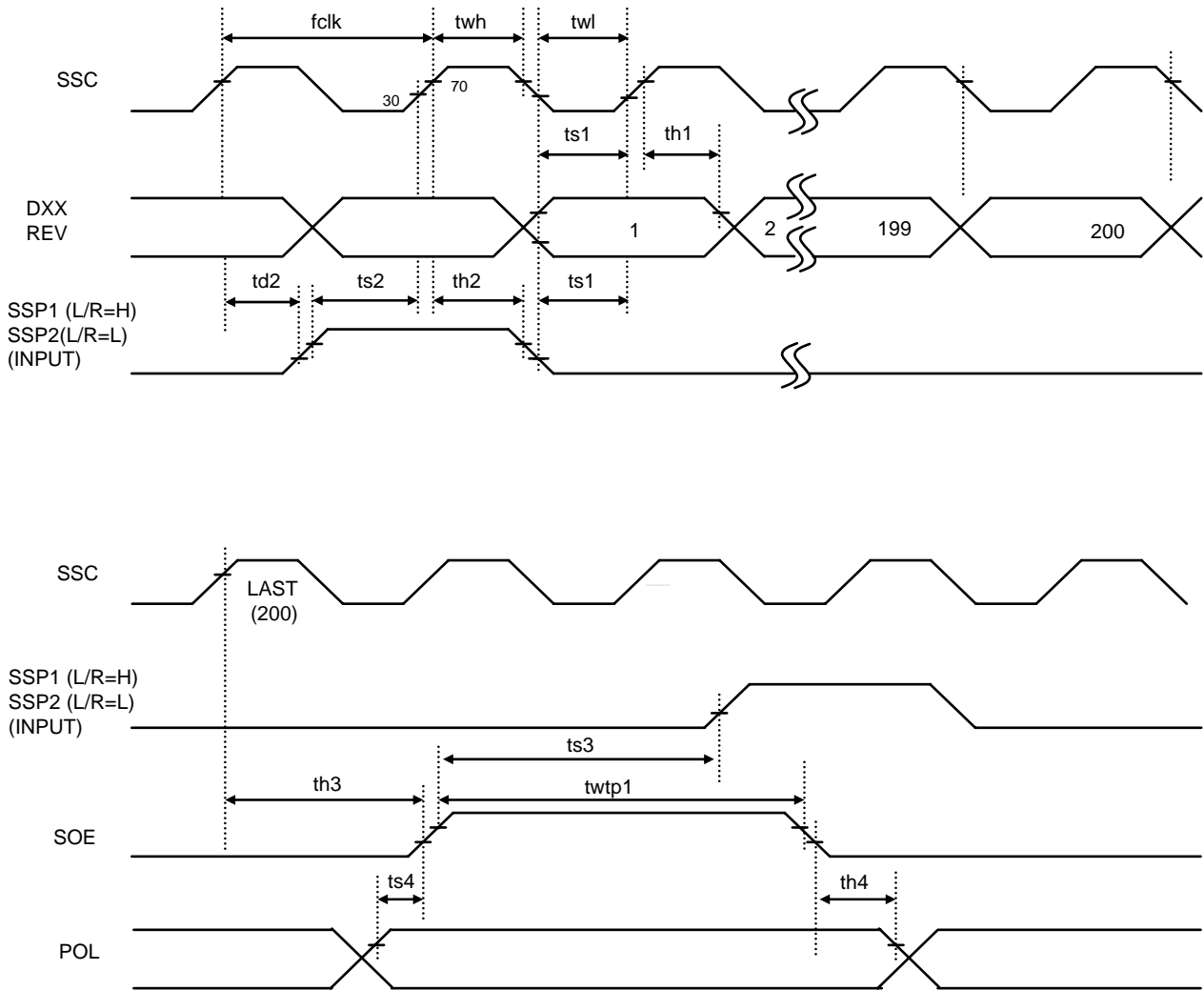

**Product Specification**

Gate D-IC Timing Diagram

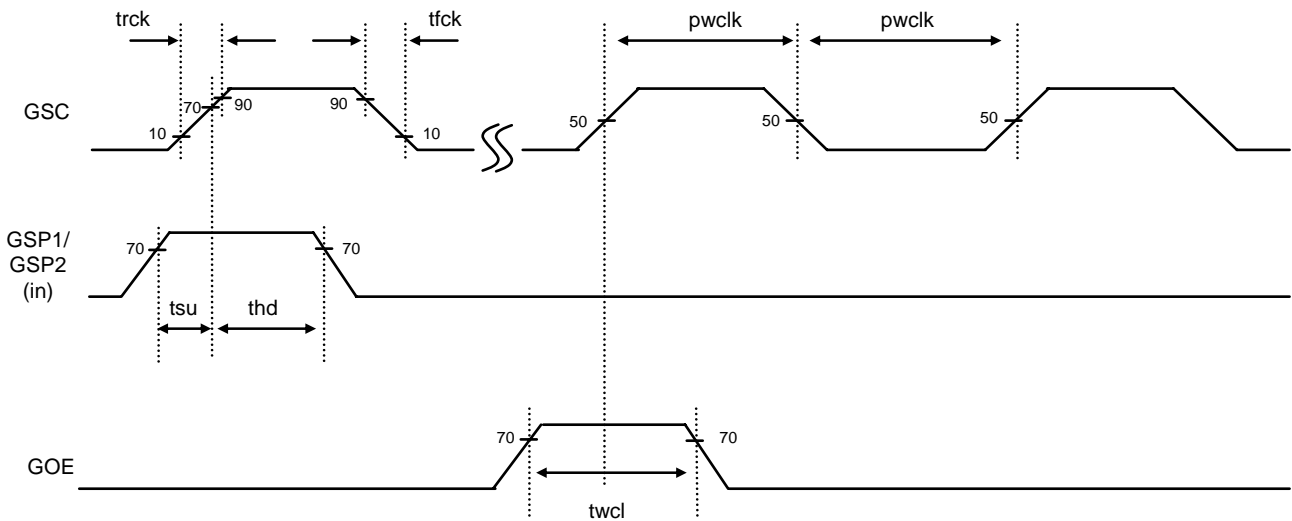





**Product Specification**

[Note 7-1] Contrast ratio is defined as follows ;

$$\text{Contrast Ratio(CR)} = \frac{\text{Photo detector output with LCD being "white"}}{\text{Photo detector output with LCD being "black"}}$$

[Note 7-2] Viewing angle range is defined as follows;

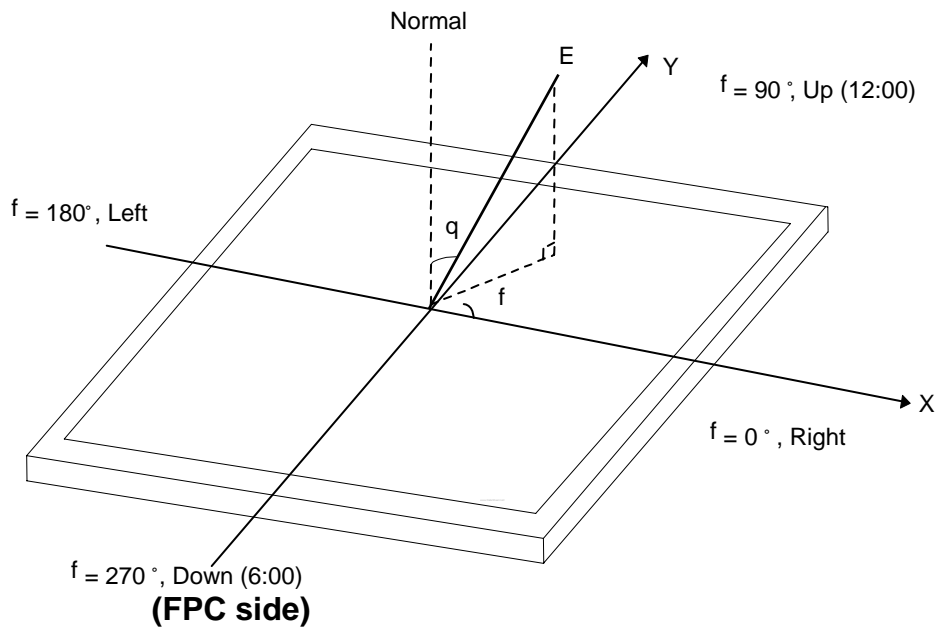

[Note 7-3]

Response time is obtained by measuring the transition time of photo detector output, when input signals are applied so as to make the area "black" to and from "white".

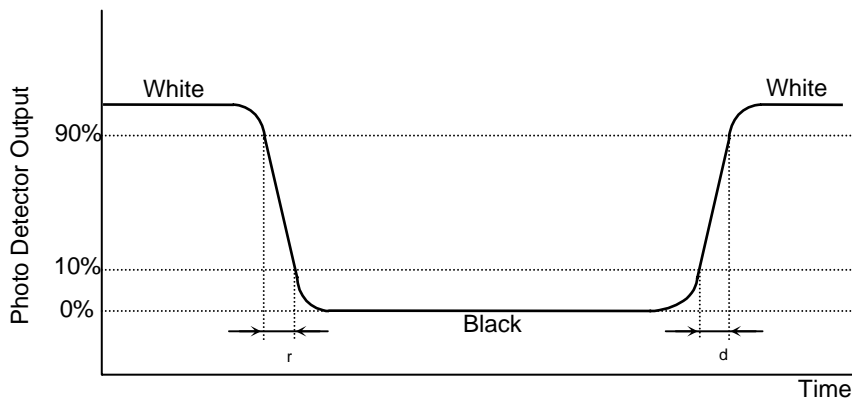

**Product Specification**

**8. Mechanical Characteristics**

Parameter	Specification		Unit	Notes
Outline Dimension	Horizontal	230.6(± 0.5)	mm	
	Vertical	142.2(± 0.5)	mm	
	Depth	1.7 ± 0.3	mm	
Active Display Area	Horizontal	222.0	mm	
	Vertical	133.2	mm	
Weight	114.2(Typ.), 126 (Max)		g	
Surface Treatment	Anti-Glare Treatment		-	

**Product Specification**

**[ Outline Dimension ]**

Note) Unit:[mm], General tolerance: ± 0.5mm

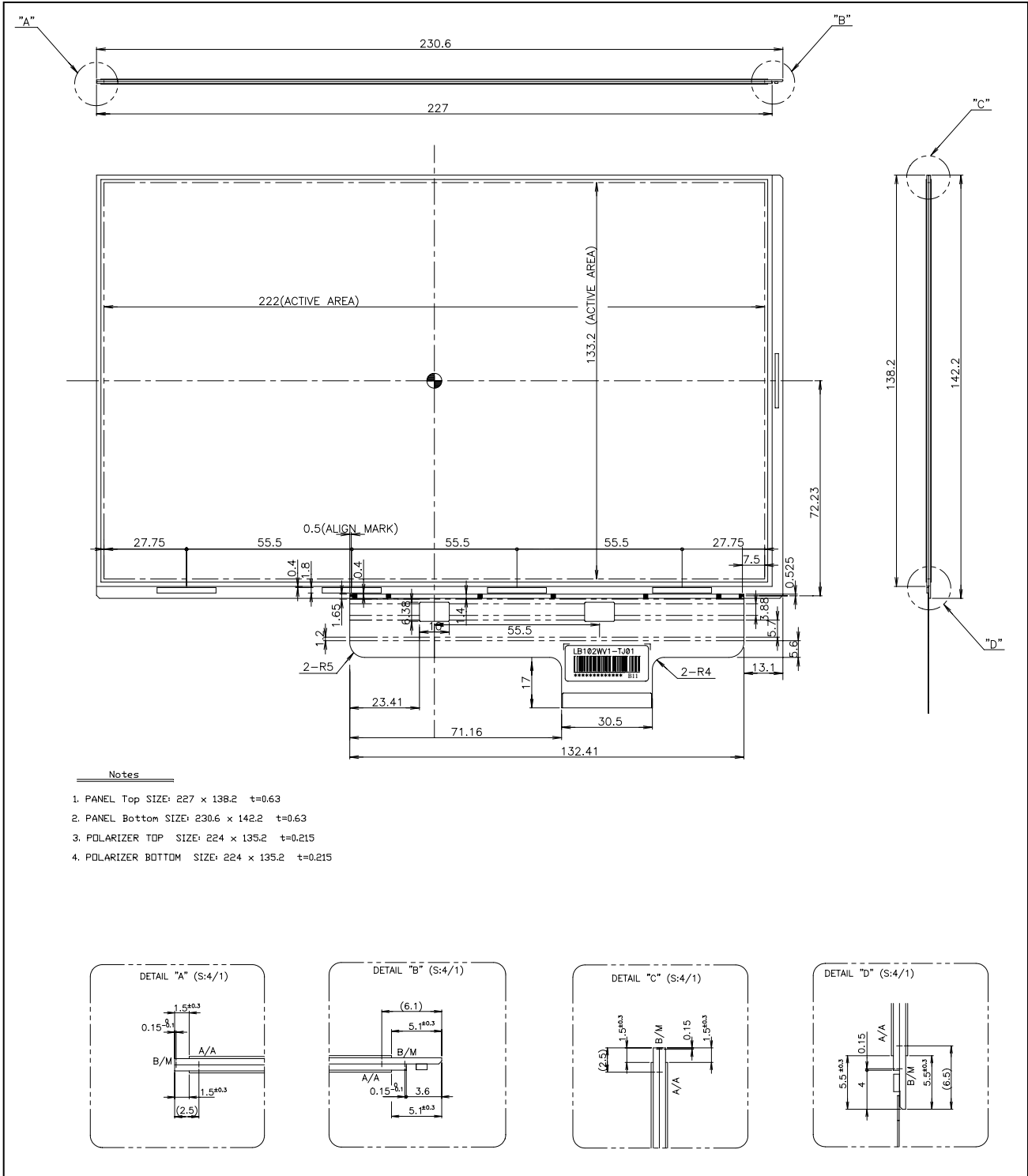

- Notes**
1. PANEL Top SIZE: 227 × 138.2 t=0.63
  2. PANEL Bottom SIZE: 230.6 × 142.2 t=0.63
  3. POLARIZER TOP SIZE: 224 × 135.2 t=0.215
  4. POLARIZER BOTTOM SIZE: 224 × 135.2 t=0.215

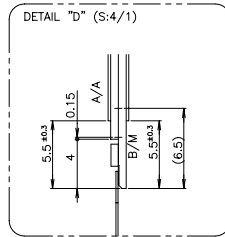
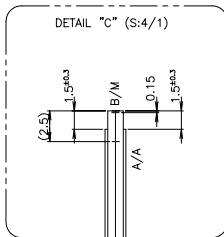
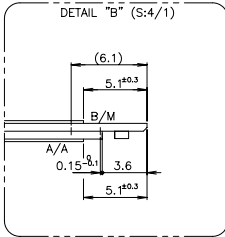
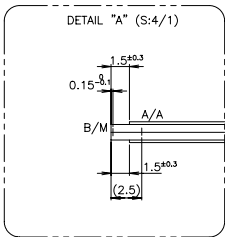

**Product Specification**

**9. Reliability Test**

No	Test Items	Test Condition	Notes
1	High Temperature Storage Test	Ta=70 240h	
2	Low Temperature Storage Test	Ta=-20 240h	
3	High Temperature Operation Test	Ta=60 240h	
4	Low Temperature Operation Test	Ta=-10 240h	
5	High Temperature and High Humidity Operation Test	Ta=50 80%RH 240h	
6	Thermal Shock Test	-20 (0.5h) ~ 70 (0.5h) / 100 cycles	

Note)

1. T<sub>a</sub> = Ambient Temperature.
2. In the normal condition after test, there shall be no display NG issue occurred.  
All the cosmetic specification is judged before the reliability stress.

**Product Specification**

**10. Packing**

**10-1. Designation of Lot Mark**

a) Lot Mark

A	B	C	D	E	F	G	H	I	J	K	L	M
---	---	---	---	---	---	---	---	---	---	---	---	---

A,B,C : SIZE(INCH)  
E : MONTH

D : YEAR  
F ~ M : SERIAL NO.

Note

1. YEAR

Year	2001	2002	2003	2004	2005	2006	2007	2008	2009	2010
Mark	1	2	3	4	5	6	7	8	9	0

2. MONTH

Month	Jan	Feb	Mar	Apr	May	Jun	Jul	Aug	Sep	Oct	Nov	Dec
Mark	1	2	3	4	5	6	7	8	9	A	B	C

b) Location of Lot Mark

Serial NO. is printed on the label. The label is attached to the front side of assembly.  
This is subject to change without prior notice.

**Product Specification**

**10-2. Packing Form**

- a) Package quantity in one box :40 pcs
- b) Box Size : 465 X 338 X 174 (mm)

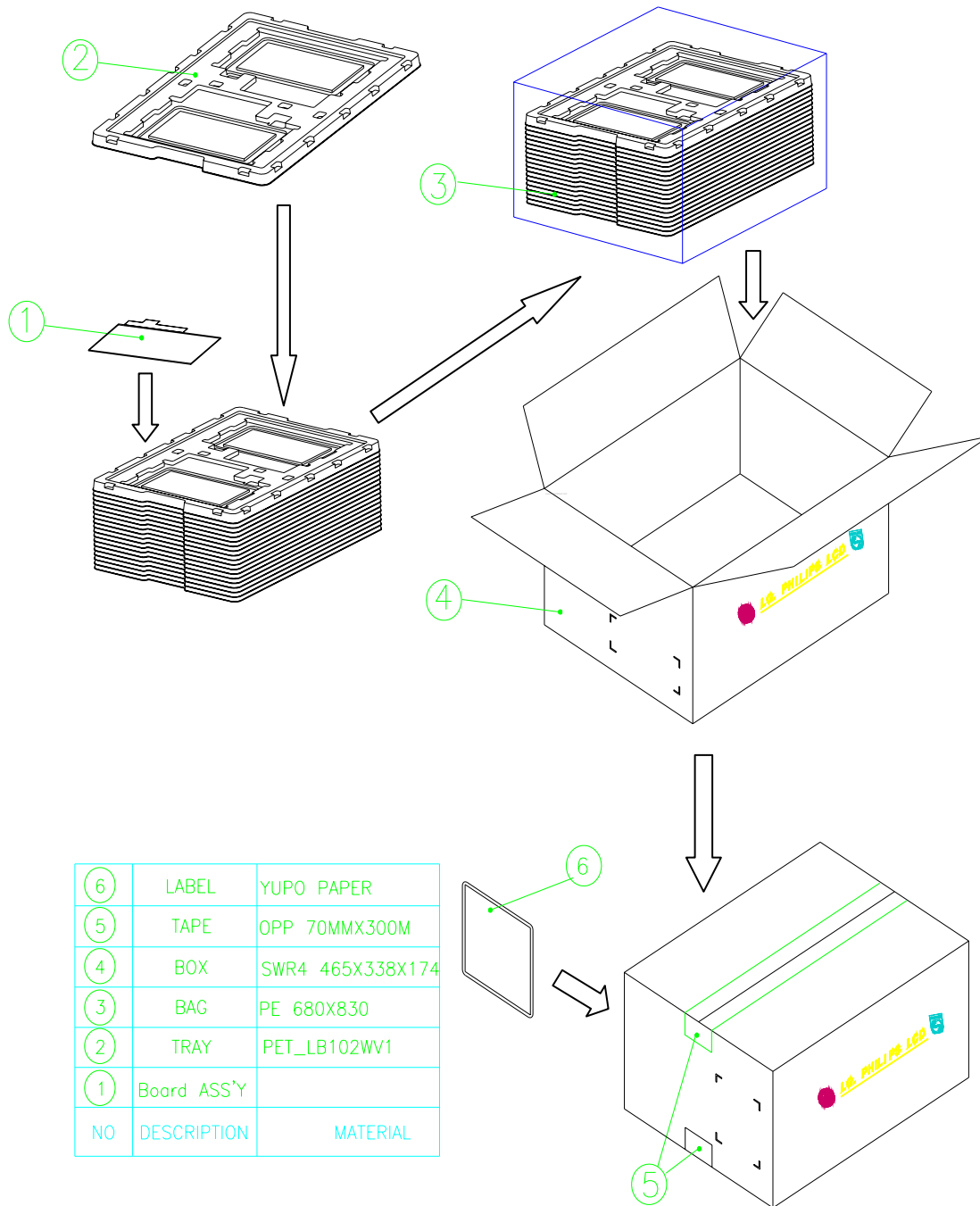

⑥	LABEL	YUPO PAPER
⑤	TAPE	OPP 70MMX300M
④	BOX	SWR4 465X338X174
③	BAG	PE 680X830
②	TRAY	PET_LB102WV1
①	Board ASS'Y	
NO	DESCRIPTION	MATERIAL

## Product Specification

### 11. Precautions

Please pay attention to the following when you use this TFT LCD module.

#### 11-1. Mounting Precautions

- (1) You should consider the mounting structure so that uneven force(ex. Twisted stress) is not applied to the module.  
And the case on which a module is mounted should have sufficient strength so that external force is not transmitted directly to the module.
- (2) Please attach a transparent protective plate to the surface in order to protect the polarizer.  
Transparent protective plate should have sufficient strength in order to resist external force.
- (3) You should adopt radiation structure to satisfy the temperature specification.
- (4) Acetic acid type and chlorine type materials for the cover case are not desirable because the former generates corrosive gas of attacking the polarizer at high temperature and the latter causes circuit break by electro-chemical reaction.
- (5) Do not touch, push or rub the exposed polarizers with glass, tweezers or anything harder than HB pencil lead. And please do not rub with dust clothes with chemical treatment.  
Do not touch the surface of polarizer for bare hand or greasy cloth.(Some cosmetics deteriorate the polarizer.)
- (6) When the surface becomes dusty, please wipe gently with absorbent cotton or other soft materials like chamois soaks with petroleum benzine. Normal-hexane is recommended for cleaning the adhesives used to attach front / rear polarizers. Do not use acetone, toluene and alcohol because they cause chemical damage to the polarizer.
- (7) Wipe off saliva or water drops as soon as possible. Their long time contact with polarizer causes deformations and color fading.
- (8) The metal case of a module should be contacted to electrical ground of your system.

#### 11-2. Operating Precautions

- (1) The spike noise causes the mis-operation of circuits. It should be lower than following voltage :  
 $V = \pm 200\text{mV}$ (Over and under shoot voltage)
- (2) Response time depends on the temperature.(In lower temperature, it becomes longer.)
- (3) Brightness depends on the temperature. (In lower temperature, it becomes lower.)  
And in lower temperature, response time(required time that brightness is stable after turned on) becomes longer.
- (4) Be careful for condensation at sudden temperature change. Condensation makes damage to polarizer or electrical contacted parts. And after fading condensation, smear or spot will occur.
- (5) When fixed patterns are displayed for a long time, remnant image is likely to occur.
- (6) Module has high frequency circuits. Sufficient suppression to the electromagnetic interference shall be done by system manufacturers. Grounding and shielding methods may be important to minimize the interference.

## Product Specification

### 11-3. Electrostatic Discharge Control

Since a module is composed of electronic circuits, it is not strong to electrostatic discharge. Make certain that treatment persons are connected to ground through wrist band etc. And don't touch interface pin directly.

### 11-4. Precautions for Strong Light Exposure

Strong light exposure causes degradation of polarizer and color filter.

### 11-5. Storage

When storing modules as spares for a long time, the following precautions are necessary.

- (1) Store them in a dark place. Do not expose the module to sunlight or fluorescent light. Keep the temperature between 5°C and 35°C at normal humidity.
- (2) The polarizer surface should not come in contact with any other object.  
It is recommended that they be stored in the container in which they were shipped.

### 11-6. Handling Precautions for Protection Film

- (1) When the protection film is peeled off, static electricity is generated between the film and polarizer. This should be peeled off slowly and carefully by people who are electrically grounded and with well ion-blown equipment or in such a condition, etc.
- (2) The protection film is attached to the polarizer with a small amount of glue. If some stress is applied to rub the protection film against the polarizer during the time you peel off the film, the glue is apt to remain on the polarizer.  
Please carefully peel off the protection film without rubbing it against the polarizer.
- (3) When the module with protection film attached is stored for a long time, sometimes there remains a very small amount of glue still on the polarizer after the protection film is peeled off.
- (4) You can remove the glue easily. When the glue remains on the polarizer surface or its vestige is recognized, please wipe them off with absorbent cotton waste or other soft material like chamois soaked with normal-hexane.