

# SPECIFICATION FOR APPROVAL

- ( ) Preliminary Specification
- ( ) Final Specification

Title	10.4" SVGA TFT LCD
-------	--------------------

Customer	
MODEL	

SUPPLIER	LG.Philips LCD Co., Ltd.
MODEL	LB104S01
Suffix	TL01

SIGNATURE	DATE
/	_____
/	_____
/	_____

Please return 1 copy for your confirmation with your signature and comments.

SIGNATURE	DATE
C.S. Kyoung / G.Manager	_____
<b>REVIEWED BY</b>	
B.H.Ahn / Manager	_____
<b>PREPARED BY</b>	
H.Y.Lim / Engineer	_____

**Products Engineering Dept.  
LG. Philips LCD Co., Ltd**

Product Specification

Contents

No	ITEM	Page
	COVER	1
	CONTENTS	2
	RECORD OF REVISIONS	3
1	GENERAL DESCRIPTION	4
2	ABSOLUTE MAXIMUM RATINGS	5
3	ELECTRICAL SPECIFICATIONS	
3-1	ELECTRICAL CHARACTREISTICS	6
3-2	INTERFACE CONNECTIONS	7
3-3	SIGNAL TIMING SPECIFICATIONS	9
3-4	SIGNAL TIMING WAVEFORMS	9
3-5	COLOR INPUT DATA REFERNECE	10
3-6	POWER SEQUENCE	11
4	OPTICAL SFECIFICATIONS	12
5	MECHANICAL CHARACTERISTICS	16
6	RELIABLITY	20
7	INTERNATIONAL STANDARDS	
7-1	SAFETY	21
7-2	EMC	21
8	PACKING	
8-1	DESIGNATION OF LOT MARK	22
8-2	PACKING FORM	23
9	PRECAUTIONS	24
A	APPENDIX. Enhanced Extended Display Identification Data	26

## Product Specification

**RECORD OF REVISIONS**

Revision No	Revision Date	Page	Description
0.0	June. 20. 2005	-	First Draft
0.1	Aug. 22. 2005	4/24	Changed Power Consumption : Total 4W(typ)→3.66W(typ), Changed Weight: 300g(typ)→290g(typ)
		6/24	Changed Power Consumption : 0.7W(typ)→0.55W(typ),0.9W(max)→0.63W(max)
		16/24	Changed Weight: 300g(typ)→290g(typ), 310g(max)→300g(max)
		17/24	Changed drawing of Front View
		18/24	Changed drawing of Rear View
		20/24	Vibration test (non-operating) condition was changed :[Sine wave, 10 ~ 500 ~ 10Hz, 1.5G, 0.37oct/min 3 axis, 1hour/axis]→[Random, 10 ~ 300Hz,0.0035~0.0035G/Hz 1.0Grms, 1 axis, 0.5hour/axis]
		20/24	Shock test (non-operating) was changed :[Half sine wave, 180G, 2ms one shock of each six faces(i.e. run 180G 6ms for all six faces)]→[ Half sine wave, 180G, 2ms one shock of each three faces (i.e. run 180G 6ms for all one faces)]
		6/24	Notes of Lamp specification was updated.
1.0	Oct. 21. 2005	6/24	Changed Operating Voltage & Operating Current : $V_{BL.min}$ : 460 →473 : $I_{BL.max}$ : 7.0mA →6.5mA
		1/24	Preliminary Specification → Final Specification
1.1	Oct. 25. 2005	4/24	Changed Power Consumption : Total 3.66 W(Typ.) → Total 3.55 W(Typ.)
		6/24	Changed Lamp Operating Voltage : Min 473 $V_{RMS}$ / Typ 485 $V_{RMS}$ / Max 625 $V_{RMS}$ → Min 488 $V_{RMS}$ / Typ 500 $V_{RMS}$ / Max 640 $V_{RMS}$ Changed Power Consumption : Typ 2.9W / Max 3.2W → Typ 3.0W / Max 3.3W Changed Note

Product Specification

### 1. General Description

The LB104S01 is a Color Active Matrix Liquid Crystal Display with an integral Cold Cathode Fluorescent Lamp (CCFL) backlight system. The matrix employs a-Si Thin Film Transistor as the active element. It is a transmissive type display operating in the normally white mode. This TFT-LCD has 10.4 inches diagonally measured active display area with SVGA resolution(600 vertical by 800 horizontal pixel array). Each pixel is divided into Red, Green and Blue sub-pixels or dots which are arranged in vertical stripes. Gray scale or the brightness of the sub-pixel color is determined with a 6-bit gray scale signal for each dot, thus, presenting a palette of more than 262,144 colors.

The LB104S01 has been designed to apply the interface method that enables low power, high speed, low EMI.

The LB104S01 is intended to support applications where thin thickness, low power are critical factors and graphic displays are important. In combination with the vertical arrangement of the sub-pixels, the LB104S01 characteristics provide an excellent flat display for office automation products such as Mini-Notebook PC or Web-pad, etc.

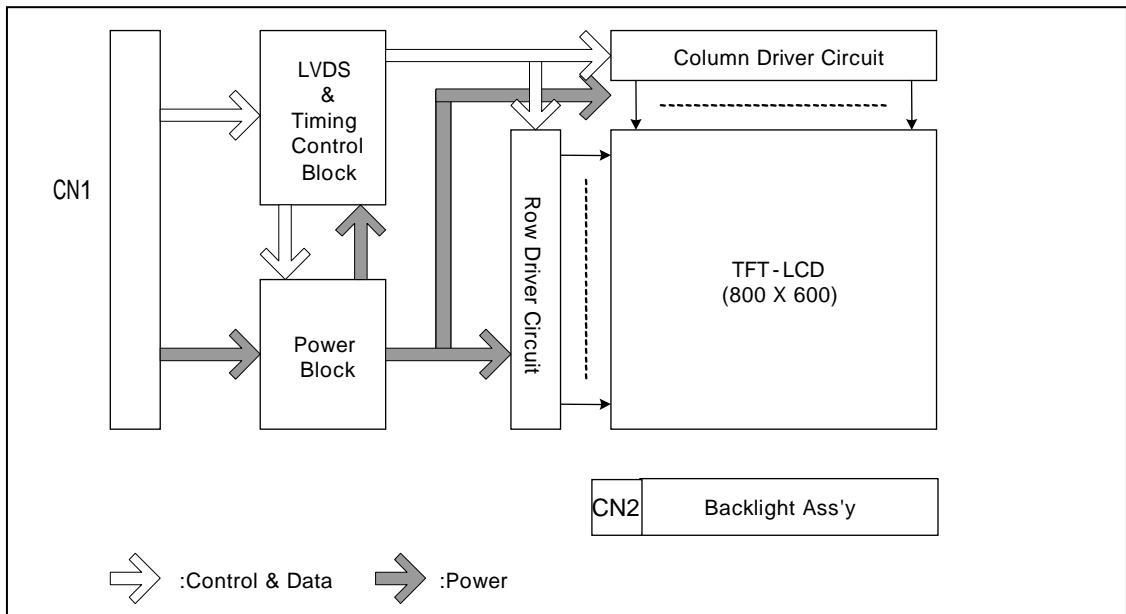

### General Features

Active Screen Size	10.4 inches (264.16mm) diagonal
Outline Dimension	224.5(H) x 172.0(V) x 5.7(D) mm(Typ.)
Pixel Pitch	0.264(H) mm x 0.264(V)mm
Pixel Format	800(H) By 600 (V) Pixels RGB stripes arrangement
Color Depth	6-bit, 262,144 colors
Luminance, White	250 cd/m <sup>2</sup> (Typ.)
Power Consumption	Total 3.55 Watt(Typ.)
Weight	290g(Typ.)
Display Operating Mode	Transmissive mode, normally white
Surface Treatment	Anti-glare& hard coating(3H)

Product Specification

## 2. Absolute Maximum Ratings

The following are maximum values which, if exceeded, may cause faulty operation or damage to the unit.

**Table 1. ABSOLUTE MAXIMUM RATINGS**

Parameter	Symbol	Values		Units	Notes
		Min	Max		
Power Input Voltage	VCC	-0.3	4.0	Vdc	at 25 ± 5°C
Operating Temperature	TOP	0	50	°C	1
Storage Temperature	HST	-20	60	°C	1
Operating Ambient Humidity	HOP	10	90	%RH	1
Storage Humidity	HST	10	90	%RH	1

Note : 1. Temperature and relative humidity range are shown in the figure below.  
Wet bulb temperature should be 39°C Max, and no condensation of water.

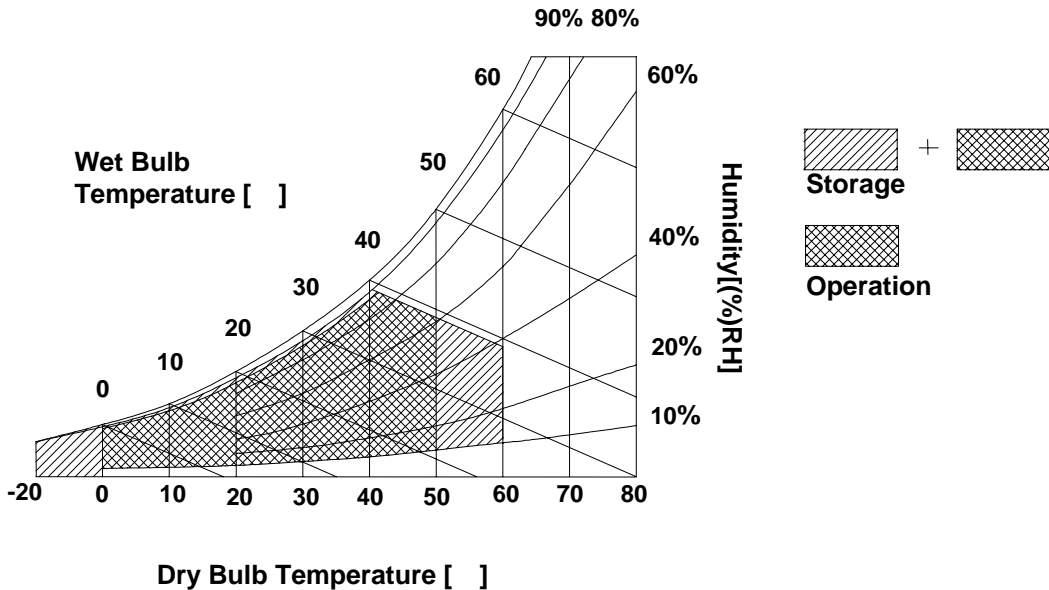

## Product Specification

### 3. Electrical Specifications

#### 3-1. Electrical Characteristics

The LB104S01 requires two power inputs. One is employed to power the LCD electronics and to drive the TFT array and liquid crystal. The second input which powers the CCFL, is typically generated by an inverter. The inverter is an external unit to the LCD.

**Table 2. ELECTRICAL CHARACTERISTICS**

Parameter	Symbol	Values			Unit	Notes
		Min	Typ	Max		
MODULE :						
Power Supply Input Voltage	VCC	3.0	3.3	3.6	V <sub>DC</sub>	
Power Supply Input Current	I <sub>CC</sub>	-	165	190	mA	1
Power Consumption	P <sub>c</sub>	-	0.55	0.63	Watt	1
Differential Impedance	Z <sub>m</sub>	90	100	110	Ohm	2
LAMP :						
Operating Voltage	V <sub>BL</sub>	488 (6.5 mA <sub>RMS</sub> )	500 (6.0 mA <sub>RMS</sub> )	640 (2.0 mA <sub>RMS</sub> )	V <sub>RMS</sub>	Tolerance: ± 10%
Operating Current	I <sub>BL</sub>	2.0	6.0	6.5	mA <sub>RMS</sub>	3
Power Consumption	P <sub>BL</sub>	-	3.0	3.3	W	@ 6mA <sub>RMS</sub>
Operating Frequency	f <sub>BL</sub>	45	60	80	kHz	
Discharge Stabilization Time	T <sub>s</sub>	-	-	3	Min	4
Life Time		20,000	-	-	Hrs	5
Established Starting Voltage at 25 at 0	V <sub>s</sub>			845 1015	V <sub>RMS</sub> V <sub>RMS</sub>	6

**Note)**

- The specified current and power consumption are under the V<sub>cc</sub> = 3.3V , 25 , f<sub>v</sub> = 60Hz condition whereas full black pattern is displayed and f<sub>v</sub> is the frame frequency.
- This impedance value is needed to proper display and measured form LVDS Tx to the mating connector.
- The typical operating current is 6mA<sub>RMS</sub> for the typical surface luminance (L<sub>WH</sub>) in optical characteristics.
- Define the brightness of the lamp after being lighted for 5 minutes as 100%, T<sub>s</sub> is the time required for the brightness of the center of the lamp to be not less than 95%.
- The life time is determined as the time at which brightness of lamp is 50% compare to that of initial value at the typical lamp current.
- The "Max" of "Established Starting Voltage" means the minimum voltage for inverter to turn on the CCFL normally in the LCD module. It should be careful that "Established Starting Voltage" is changed by an increase of stray capacitance in your set, inverter method, value of ballast capacitor in your inverter and so on. Especially, the value of "Established Starting Voltage" is higher in low temperature condition than in normal temperature condition, because impedance of CCFL is increased. The voltage above V<sub>s</sub> should be applied to the lamps for more than 1 second for start-up.
- Lamp frequency may produce interface with horizontal synchronous frequency and as a result this may cause beat on the display. Therefore lamp frequency shall be as away possible from the horizontal synchronous frequency and from its harmonics in order to prevent interference.
- The lamp power consumption shown above does not include loss of external inverter.  
The applied lamp current is a typical one.

Product Specification

Note)

9. Requirements for a system inverter design, which is intended to have a better display performance, a better power efficiency and a more reliable lamp, are following.

It shall help increase the lamp lifetime and reduce leakage current.

a. The asymmetry rate of the inverter waveform should be less than 10%.

b. The distortion rate of the waveform should be within  $2 \pm 10\%$ .

\* Inverter output waveform had better be more similar to ideal sine wave.

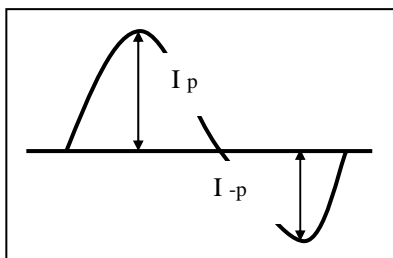

\* Asymmetry rate:

$$\frac{|I_p - I_{-p}|}{I_{RMS}} * 100\%$$

\* Distortion rate

$$I_p \text{ (or } I_{-p}) / I_{RMS}$$

Do not attach a conducting tape to lamp connecting wire.

If the lamp wire attach to a conducting tape, TFT-LCD Module has a low luminance and the inverter has abnormal action. Because leakage current is occurred between lamp wire and conducting tape.

Product Specification

### 3-2. Interface Connections

This LCD employs two interface connections, a 20 pin connector is used for the module electronics interface and the other connector is used for the integral backlight system.

The electronics interface connector is a model GT100-20P-LS-SMT manufactured by LS Cable.

**Table 3. MODULE CONNECTOR PIN CONFIGURATION (CN1)**

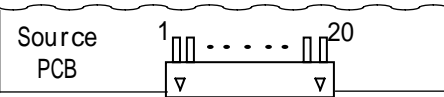
Pin	Symbol	Description	Notes
1	VCC	Power Supply, 3.3V Typ.	1, Interface chips 1.1 LCD : SW, SW0602_U(LCD Controller) including LVDS Receiver 1.2 System : THC63LVDM63A or Equivalent * Pin to Pin compatible with TI LVDS  2, Connector 2.1 LCD : GT100-20P-LS-SMT, LS Cable or Equivalent 2.2 Mating Discrete Wire type:DF19G-20S-1C(HIROSE) FPC type :DF19G-20S-1F(HIROSE) 2.3 Connector pin arrangement    [LCD Module rear view]
2	VCC	Power Supply, 3.3V Typ.	
3	GND	Ground	
4	GND	Ground	
5	A1M	Negative LVDS differential data input	
6	A1P	Positive LVDS differential data input	
7	GND	Ground	
8	A2M	Negative LVDS differential data input	
9	A2P	Positive LVDS differential data input	
10	GND	Ground	
11	A3M	Negative LVDS differential data input	
12	A3P	Positive LVDS differential data input	
13	GND	Ground	
14	CLKM	Negative LVDS differential clock input	
15	CLKP	Positive LVDS differential clock input	
16	GND	Ground	
17	GND	Ground	
18	GND	Ground	
19	GND	Ground	
20	GND	Ground	

The backlight interface connector is a model BHSR-02VS-1, manufactured by JST or Compatible.

The mating connector part number is SM02B-BHSS-1 or equivalent.

**Table 5. BACKLIGHT CONNECTOR PIN CONFIGURATION (CN2)**

Pin	Symbol	Description	Notes
1	HV	Power supply for lamp (High voltage side)	1
2	LV	Power supply for lamp (Low voltage side)	1

Notes : 1. The high voltage side terminal is colored pink and the low voltage side terminal is black.



## Product Specification

### 3-3. Signal Timing Specifications

This is the signal timing required at the input of the User connector. All of the interface signal timing should be satisfied with the following specifications and specifications of LVDS Tx/Rx for its proper operation.

**Table 6. TIMING TABLE**

ITEM	Symbol		Min	Typ	Max	Unit	Note
DCLK	Frequency	fCLK	37.0	38.5	40.0	MHz	
Hsync	Period	tHP	990	1024	1100	tCLK	
	Width	tWH	12	-	120		
Vsync	Period	tVP	606	625	730	tHP	
	Width	tWV	1	-	24		
Data Enable	Horizontal back porch	tHBP	30	-	-	tCLK	
	Horizontal front porch	tHFP	30	-	-		
	Vertical back porch	tVBP	2	-	-	tHP	
	Vertical front porch	tVFP	3	-	-		

### 3-4. Signal Timing Waveforms

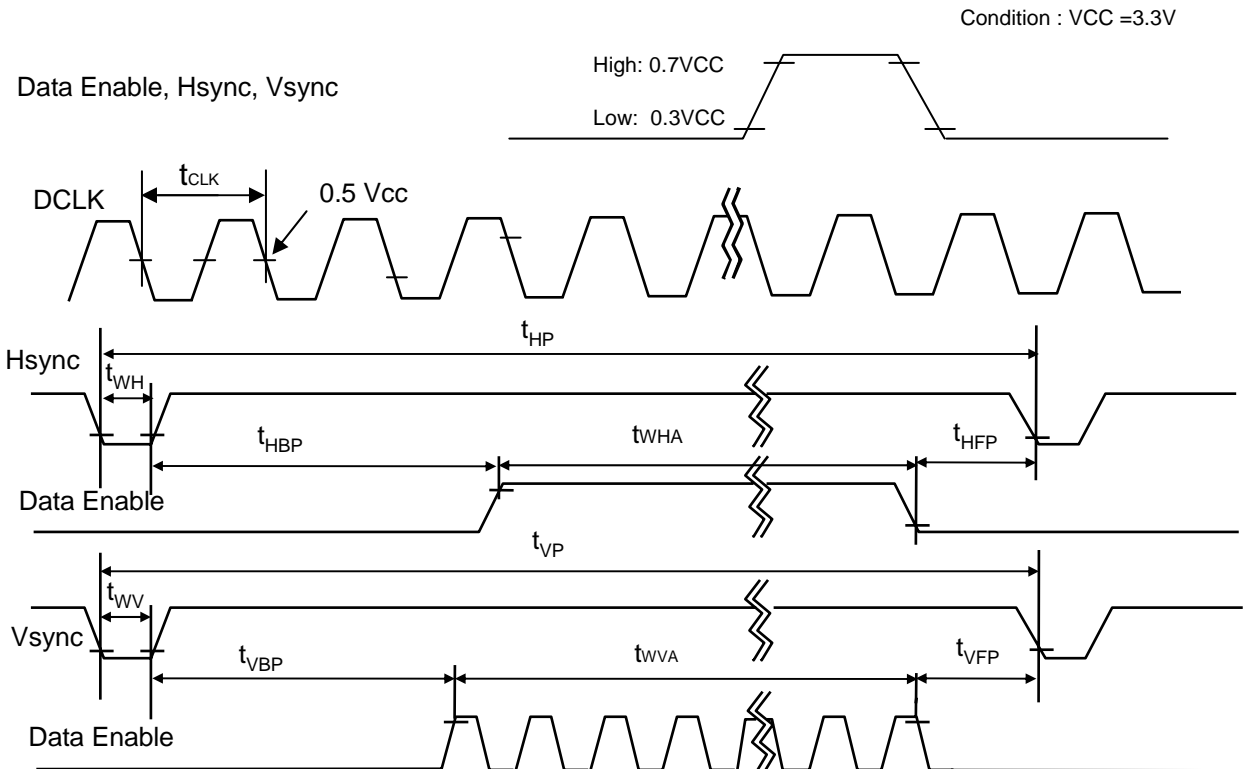

Product Specification

### 3-5. Color Input Data Reference

The brightness of each primary color (red, green and blue) is based on the 6-bit gray scale data input for the color ; the higher the binary input, the brighter the color. The table below provides a reference for color versus data input.

**Table 7. COLOR DATA REFERENCE**

Color		Input Color Data																	
		RED						GREEN						BLUE					
		MSB			LSB			MSB			LSB			MSB			LSB		
		R5	R4	R3	R2	R1	R0	G5	G4	G3	G2	G1	G0	B5	B4	B3	B2	B1	B0
Basic Color	Black	0	0	0	0	0	0	0	0	0	0	0	0	0	0	0	0	0	0
	Red	1	1	1	1	1	1	0	0	0	0	0	0	0	0	0	0	0	0
	Green	0	0	0	0	0	0	1	1	1	1	1	1	0	0	0	0	0	0
	Blue	0	0	0	0	0	0	0	0	0	0	0	0	1	1	1	1	1	1
	Cyan	0	0	0	0	0	0	1	1	1	1	1	1	1	1	1	1	1	1
	Magenta	1	1	1	1	1	1	0	0	0	0	0	0	1	1	1	1	1	1
	Yellow	1	1	1	1	1	1	1	1	1	1	1	1	0	0	0	0	0	0
	White	1	1	1	1	1	1	1	1	1	1	1	1	1	1	1	1	1	1
RED	RED (00)	0	0	0	0	0	0	0	0	0	0	0	0	0	0	0	0	0	0
	RED (01)	0	0	0	0	0	1	0	0	0	0	0	0	0	0	0	0	0	0
	...	...						...						...					
	RED (62)	1	1	1	1	1	0	0	0	0	0	0	0	0	0	0	0	0	0
	RED (63)	1	1	1	1	1	1	0	0	0	0	0	0	0	0	0	0	0	0
GREEN	GREEN (00)	0	0	0	0	0	0	0	0	0	0	0	0	0	0	0	0	0	0
	GREEN (01)	0	0	0	0	0	0	0	0	0	0	0	1	0	0	0	0	0	0
	...	...						...						...					
	GREEN (62)	0	0	0	0	0	0	1	1	1	1	1	0	0	0	0	0	0	0
	GREEN (63)	0	0	0	0	0	0	1	1	1	1	1	1	0	0	0	0	0	0
BLUE	BLUE (00)	0	0	0	0	0	0	0	0	0	0	0	0	0	0	0	0	0	0
	BLUE (01)	0	0	0	0	0	0	0	0	0	0	0	0	0	0	0	0	0	1
	...	...						...						...					
	BLUE (62)	0	0	0	0	0	0	0	0	0	0	0	0	1	1	1	1	1	0
	BLUE (63)	0	0	0	0	0	0	0	0	0	0	0	0	1	1	1	1	1	1

### 3-6. Power Sequence

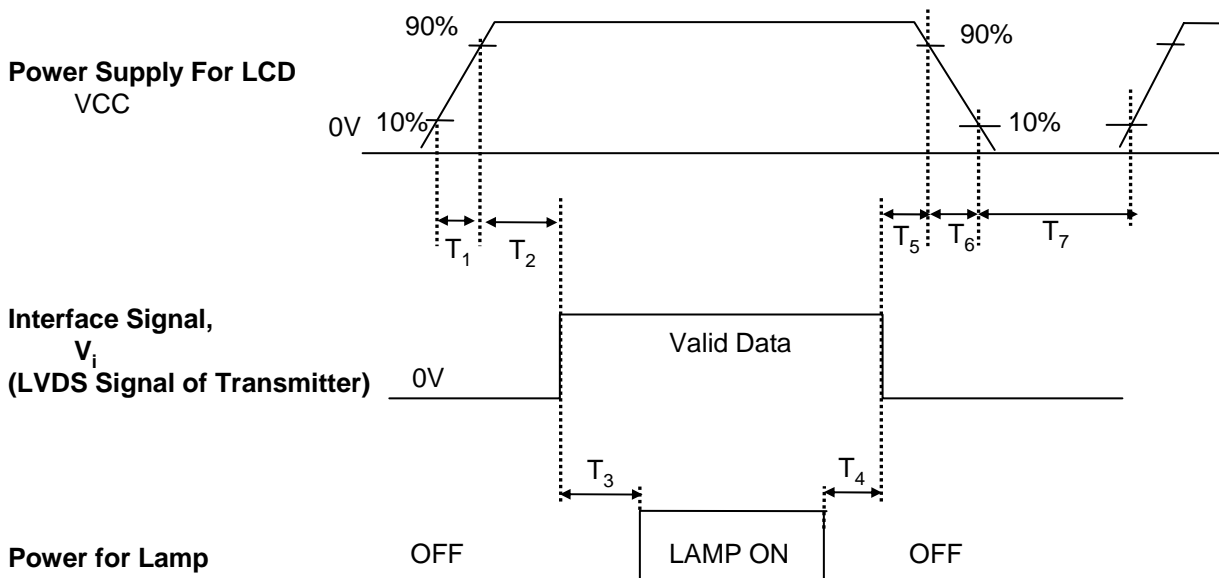

**Table 8. POWER SEQUENCE TABLE**

Parameter	Value			Units
	Min.	Typ.	Max.	
$T_1$	-	-	10	(ms)
$T_2$	0	-	50	(ms)
$T_3$	200	-	-	(ms)
$T_4$	200	-	-	(ms)
$T_5$	0	-	50	(ms)
$T_6$	-	-	10	(ms)
$T_7$	400	-	-	(ms)

Note)

1. Please avoid floating state of interface signal at invalid period.
2. When the interface signal is invalid, be sure to pull down the power supply for LCD VCC to 0V.
3. Lamp power must be turn on after power supply for LCD and interface signal are valid.

## Product Specification

## 4. Optical Specification

Optical characteristics are determined after the unit has been 'ON' and stable for approximately 30 minutes in a dark environment at 25°C. The values specified are at an approximate distance 50cm from the LCD surface at a viewing angle of  $\Phi$  and  $\Theta$  equal to 0°.

FIG. 1 presents additional information concerning the measurement equipment and method.

**FIG. 1 Optical Characteristic Measurement Equipment and Method**

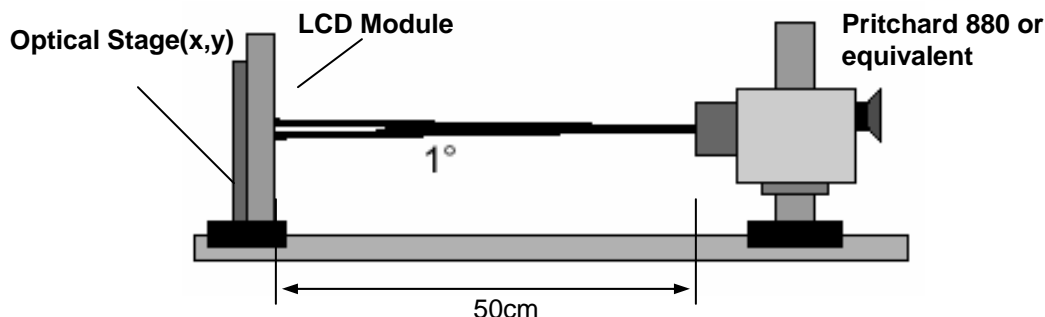

**Table 9. OPTICAL CHARACTERISTICS**

Ta=25°C, VCC=3.3V, fv=60Hz, fCLK= 38.5MHz, IBL= 6.0mA

Parameter	Symbol	Values			Units	Notes
		Min	Typ	MAx		
Contrast Ratio	CR	300	400	-		1
Surface Luminance, white	L <sub>WH</sub>	200	250	-	cd/m <sup>2</sup>	2
Luminance Variation	$\delta_{\text{WHITE}}$	-	-	1.4		3
Response Time						4
Rise Time	T <sub>R</sub>	-	6	10	ms	
Delay Time	T <sub>D</sub>	-	19	30	ms	
Color Coordinates						
RED	RX	0.543	0.573	0.603		
	RY	0.297	0.327	0.357		
GREEN	GX	0.279	0.309	0.339		
	GY	0.513	0.543	0.573		
BLUE	BX	0.118	0.148	0.178		
	BY	0.096	0.126	0.156		
WHITE	WX	0.275	0.305	0.335		
	WY	0.290	0.320	0.350		
Viewing Angle						5
x axis, right( $\Phi=0^\circ$ )	$\Theta_r$	65	-	-	degree	
x axis, left ( $\Phi=180^\circ$ )	$\Theta_l$	65	-	-	degree	
y axis, up ( $\Phi=90^\circ$ )	$\Theta_u$	45	-	-	degree	
y axis, down ( $\Phi=270^\circ$ )	$\Theta_d$	55	-	-	degree	

Product Specification

Note)

1. Contrast Ratio(CR) is defined mathematically as

$$\text{Contrast Ratio} = \frac{\text{Surface Luminance with all white pixels}}{\text{Surface Luminance with all black pixels}}$$

2. Surface luminance is the center point across the LCD surface 50cm from the surface with all pixels displaying white. For more information see FIG 1.

$$L_{WH} = L_1$$

3. The variation in surface luminance , The panel total variation ( $\delta_{WHITE}$ ) is determined by measuring  $L_N$  at each test position 1 through 5 and then defined as followed numerical formula.  
For more information see FIG 2.

$$\delta_{WHITE} = \frac{\text{Maximum}(L_1, L_2, \dots L_5)}{\text{Minimum}(L_1, L_2, \dots L_5)}$$

4. Response time is the time required for the display to transition from white to black (rise time,  $Tr_R$ ) and from black to white(Decay Time,  $Tr_D$ ). For additional information see FIG 3.
5. Viewing angle is the angle at which the contrast ratio is greater than 10. The angles are determined for the horizontal or x axis and the vertical or y axis with respect to the z axis which is normal to the LCD surface. For more information see FIG 4.

Product Specification

FIG. 2 Luminance

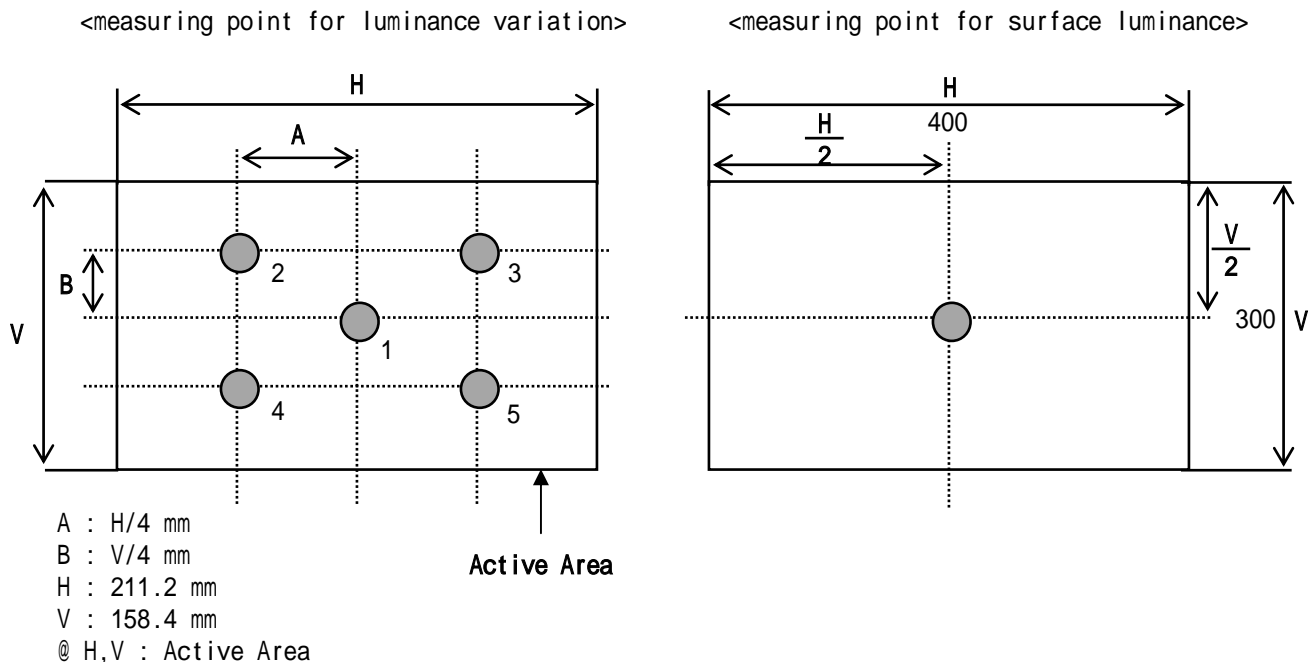
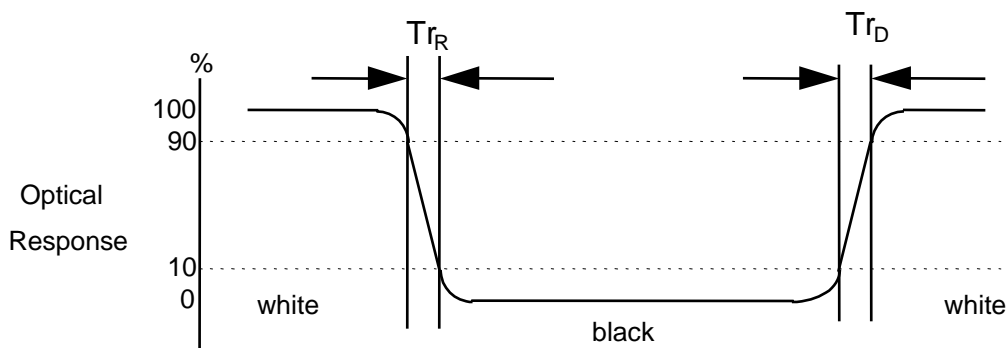

FIG. 3 Response Time

The response time is defined as the following figure and shall be measured by switching the input signal for "black" and "white".



Product Specification

FIG. 4 Viewing angle

<Dimension of viewing angle range>

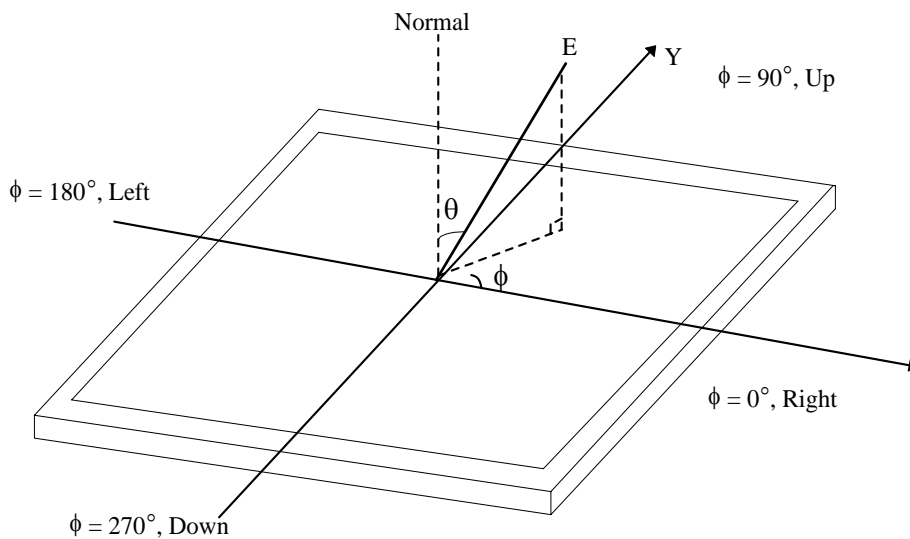

Product Specification

### 5. Mechanical Characteristics

The contents provide general mechanical characteristics for the model LB104S01. In addition the figures in the next page are detailed mechanical drawing of the LCD.

Outline Dimension	Horizontal	224.5 ± 0.5mm
	Vertical	172.0 ± 0.5mm
	Depth	5.7 ± 0.3mm
Bezel Area	Horizontal	217.2 ± 0.5mm
	Vertical	161.8 ± 0.5mm
Active Display Area	Horizontal	211.2 mm
	Vertical	158.4 mm
Weight	290g (Typ.) 300g (Max.)	



Product Specification

<FRONT VIEW>

Note) Unit:[mm], General tolerance:  $\pm 0.5$ mm

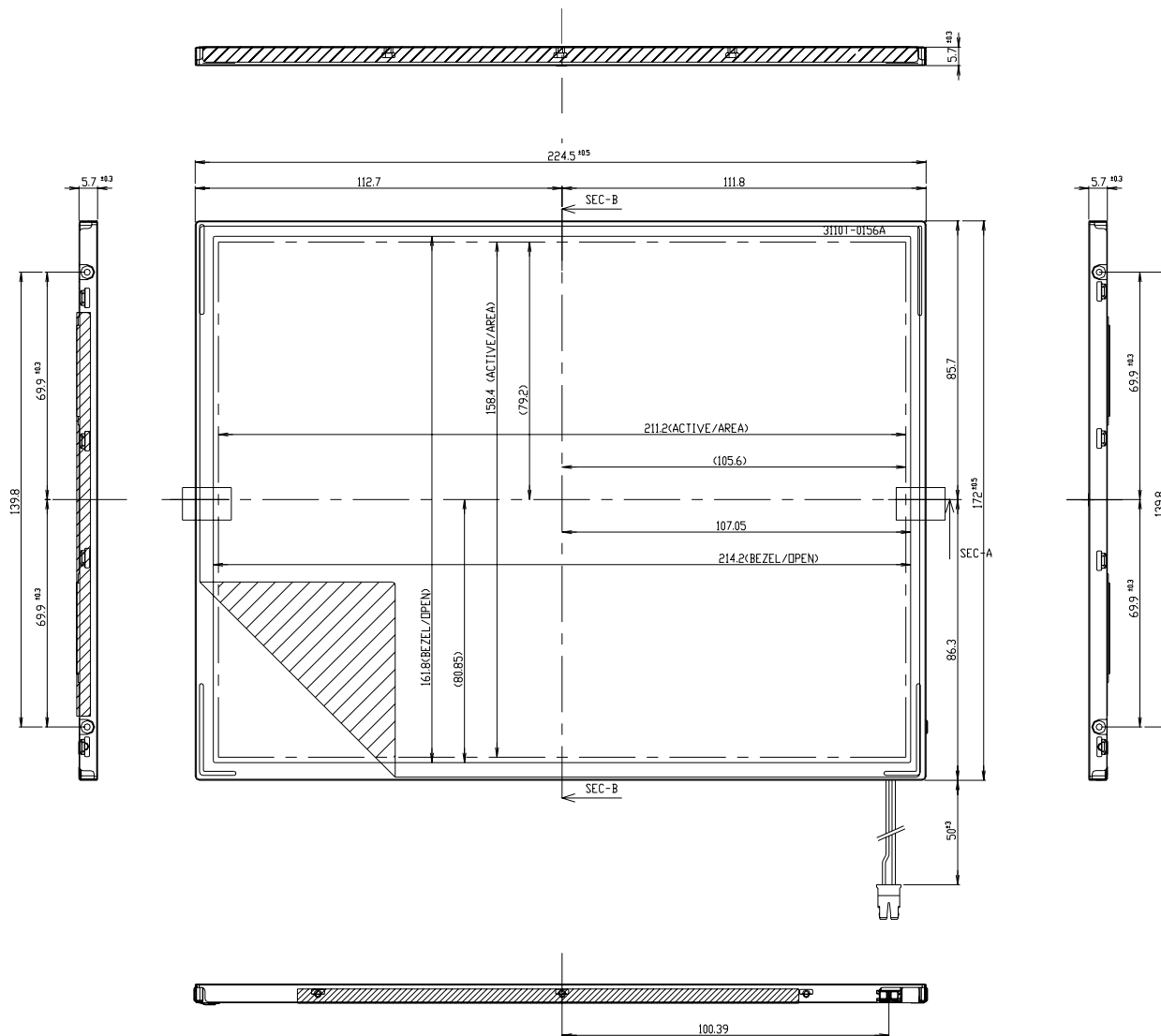

**Product Specification**

<REAR VIEW>

Note) Unit:[mm], General tolerance: ± 0.5mm

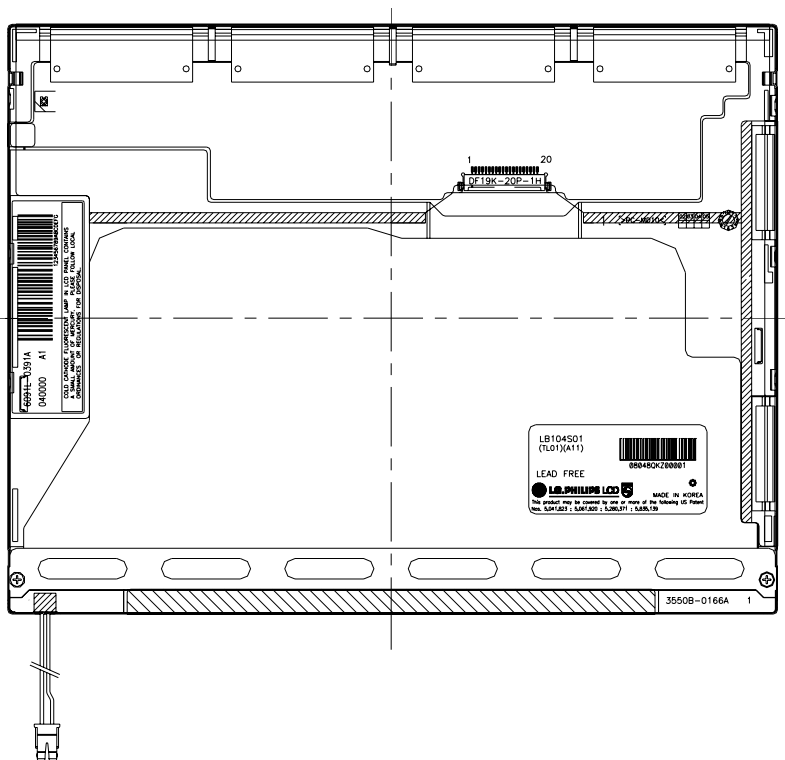

Product Specification

[ DETAIL DESCRIPTION OF SIDE MOUNTING SCREW ]

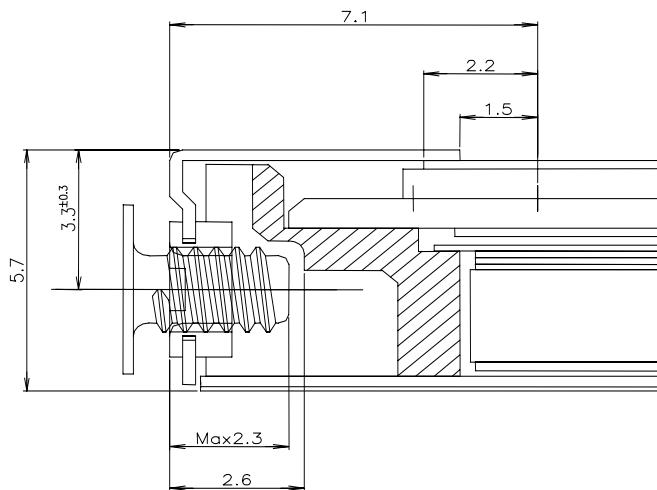

- \*Mounting screw depth : Max 2.3mm
- \*Screw(4ea) Torque : Max 2kgf•cm

Note) Unit:[mm], General tolerance: ± 0.5mm

## Product Specification

## 6. Reliability

Environment test condition

No.	Test Item	Conditions
1	High temperature storage test	Ta= 60°C, 240h
2	Low temperature storage test	Ta= -20°C, 240h
3	High temperature operation test	Ta= 50°C, 50%RH, 240h
4	Low temperature operation test	Ta= 0°C, 240h
5	Vibration test (non-operating)	Random, 10 ~ 300Hz, 0.0035~0.0035G/Hz 1.0Grms, 1 axis, 0.5hour/axis
6	Shock test (non-operating)	Half sine wave, 180G, 2ms one shock of each three faces (I.e. run 180G 6ms for all one faces)
7	Altitude operating storage / shipment	0 ~ 10,000 feet (3,048m) 24Hr 0 ~ 40,000 feet (12,192m) 24Hr

{ Result Evaluation Criteria }

There should be no change which might affect the practical display function when the display quality test is conducted under normal operating condition.

## 7. International Standards

### 7-1. Safety

- a) UL 60950-1:2003, First Edition, Underwriters Laboratories, Inc., Standard for Safety of Information Technology Equipment.
- b) CAN/CSA C22.2, No. 60950-1-03 1<sup>st</sup> Ed. April 1, 2003, Canadian Standards Association, Standard for Safety of Information Technology Equipment.
- c) EN 60950-1:2001, First Edition, European Committee for Electrotechnical Standardization(CENELEC) European Standard for Safety of Information Technology Equipment.

### 7-2. EMC

- a) ANSI C63.4 "Methods of Measurement of Radio-Noise Emissions from Low-Voltage Electrical and Electrical Equipment in the Range of 9kHz to 40GHz. "American National Standards Institute(ANSI), 1992
- b) C.I.S.P.R. "Limits and Methods of Measurement of Radio Interface Characteristics of Information Technology Equipment." International Special Committee on Radio Interference.
- c) EN 55022 "Limits and Methods of Measurement of Radio Interface Characteristics of Information Technology Equipment." European Committee for Electrotechnical Standardization.(CENELEC), 1998 ( Including A1: 2000 )

## Product Specification

## 8. Packing

### 8-1. Designation of Lot Mark

a) Lot Mark

A	B	C	D	E	F	G	H	I	J	K	L	M
---	---	---	---	---	---	---	---	---	---	---	---	---

A,B,C : Inch  
 D : Year  
 E : Month  
 F : Panel Code  
 G : Factory Code  
 H : Assembly Code  
 I,J,K,L,M : Serial No

Note

1. Year

Year	97	98	99	2000	2001	2002	2003	2004	2005	2006	2007
Mark	7	8	9	0	1	2	3	4	5	6	7

2. Month

Month	Jan	Feb	Mar	Apr	May	Jun	Jul	Aug	Sep	Oct	Nov	Dec
Mark	1	2	3	4	5	6	7	8	9	A	B	C

3. Panel Code

Panel Code	P1 Factory	P2 Factory	P3 Factory	P4 Factory	P5 Factory	Hydis Panel
Mark	1	2	3	4	5	H

4. Factory Code

Factory Code	LPL Gumi	LPL Nanjing	Hee Sung
Mark	K	C	D

5. Serial No

Serial No.	1 ~ 99,999	100,000 ~
Mark	00001 ~ 99999	A0001 ~ A9999, - - - -, Z9999

b) Location of Lot Mark

Serial NO. is printed on the label. The label is attached to the backside of the LCD module.  
 This is subject to change without prior notice.

### 8-2. Packing Form

- a) Package quantity in one box : 26 pcs
- b) Box Size : 425mm(L) × 246mm(W) × 287mm(H)

## Product Specification

## 9. PRECAUTIONS

Please pay attention to the followings when you use this TFT LCD module.

### 9-1. MOUNTING PRECAUTIONS

- (1) You must mount a module using holes arranged in four corners or four sides.
- (2) You should consider the mounting structure so that uneven force (ex. Twisted stress) is not applied to the module. And the case on which a module is mounted should have sufficient strength so that external force is not transmitted directly to the module.
- (3) Please attach the surface transparent protective plate to the surface in order to protect the polarizer. Transparent protective plate should have sufficient strength in order to resist external force.
- (4) You should adopt radiation structure to satisfy the temperature specification.
- (5) Acetic acid type and chlorine type materials for the cover case are not desirable because the former generates corrosive gas of attacking the polarizer at high temperature and the latter causes circuit break by electro-chemical reaction.
- (6) Do not touch, push or rub the exposed polarizers with glass, tweezers or anything harder than HB pencil lead. And please do not rub with dust clothes with chemical treatment. Do not touch the surface of polarizer for bare hand or greasy cloth. (Some cosmetics are detrimental to the polarizer.)
- (7) When the surface becomes dusty, please wipe gently with absorbent cotton or other soft materials like chamois soaks with petroleum benzene. Normal-hexane is recommended for cleaning the adhesives used to attach front / rear polarizers. Do not use acetone, toluene and alcohol because they cause chemical damage to the polarizer.
- (8) Wipe off saliva or water drops as soon as possible. Their long time contact with polarizer causes deformations and color fading.
- (9) Do not open the case because inside circuits do not have sufficient strength.

### 9-2. OPERATING PRECAUTIONS

- (1) The spike noise causes the mis-operation of circuits. It should be lower than following voltage :  
 $V = \pm 200\text{mV}$  (Over and under shoot voltage)
- (2) Response time depends on the temperature. (In lower temperature, it becomes longer.)
- (3) Brightness depends on the temperature. (In lower temperature, it becomes lower.)  
And in lower temperature, response time (required time that brightness is stable after turned on) becomes longer.
- (4) Be careful for condensation at sudden temperature change. Condensation makes damage to polarizer or electrical contacted parts. And after fading condensation, smear or spot will occur.
- (5) When fixed patterns are displayed for a long time, remnant image is likely to occur.
- (6) Module has high frequency circuits. Sufficient suppression to the electromagnetic interference shall be done by system manufacturers. Grounding and shielding methods may be important to minimize the interference.

## Product Specification

**9-3. ELECTROSTATIC DISCHARGE CONTROL**

Since a module is composed of electronic circuits, it is not strong to electrostatic discharge. Make certain that treatment persons are connected to ground through wrist band etc. And don't touch interface pin directly.

**9-4. PRECAUTIONS FOR STRONG LIGHT EXPOSURE**

Strong light exposure causes degradation of polarizer and color filter.

**9-5. STORAGE**

When storing modules as spares for a long time, the following precautions are necessary.

- (1) Store them in a dark place. Do not expose the module to sunlight or fluorescent light. Keep the temperature between 5°C and 35°C at normal humidity.
- (2) The polarizer surface should not come in contact with any other object.  
It is recommended that they be stored in the container in which they were shipped.

**9-6. HANDLING PRECAUTIONS FOR PROTECTION FILM**

- (1) When the protection film is peeled off, static electricity is generated between the film and polarizer.  
This should be peeled off slowly and carefully by people who are electrically grounded and with well ion-blown equipment or in such a condition, etc.
- (2) The protection film is attached to the polarizer with a small amount of glue. If some stress is applied to rub the protection film against the polarizer during the time you peel off the film, the glue is apt to remain on the polarizer.  
Please carefully peel off the protection film without rubbing it against the polarizer.
- (3) When the module with protection film attached is stored for a long time, sometimes there remains a very small amount of glue still on the polarizer after the protection film is peeled off.
- (4) You can remove the glue easily. When the glue remains on the polarizer surface or its vestige is recognized, please wipe them off with absorbent cotton waste or other soft material like chamois soaked with normal-hexane.