

**Product Specification**

# SPECIFICATION FOR APPROVAL

- ( ◆ ) Preliminary Specification
- (   ) Final Specification

Title	10.4" SVGA TFT LCD
-------	--------------------

Customer	
MODEL	

SUPPLIER	LG Display Co., Ltd.
*MODEL	LB104S04
Suffix	TL01

\*When you obtain standard approval,  
please use the above model name without suffix

APPROVED BY	SIGNATURE
/	_____
/	_____
/	_____

Please return 1 copy for your confirmation with your signature and comments.

APPROVED BY	SIGNATURE
Y. T. Woo / G.Manager	_____
<b>REVIEWED BY</b>	
K. H. Choi / Manager [C]	_____
B. C. Lee / Manager [M]	_____
J. K. Kim / Manager [P]	_____
<b>PREPARED BY</b>	
T. I. Oh / Engineer	_____

Products Engineering Dept.  
LG Display Co., Ltd

**Product Specification**
Contents

No.	ITEM	Page
	COVER	0
	CONTENTS	1
	RECORD OF REVISIONS	2
1	SUMMARY	3
2	FEATURES	3
3	GENERAL DESCRIPTION	4
4	ABSOLUTE MAXIMUM RATINGS	5
5	ELECTRICAL SPECIFICATIONS	6
5-1	ELECTRICAL CHARACTERISTICS	6
5-2	INTERFACE CONNECTIONS	8
5-3	SIGNAL TIMING SPECIFICATIONS	12
5-4	LVDS SIGNAL SPECIFICATIONS	12
5-5	COLOR DATA REFERENCE	15
5-6	POWER SEQUENCE	16
6	ELECTRO-OPTICAL SPECIFICATIONS	17
7	MECHANICAL CHARACTERISTICS	21
8	RELIABILITY	24
9	INTERNATIONAL STANDARDS	25
9-1	SAFETY	25
9-2	ENVIRONMENT	25
10	PACKING	26
10-1	DESIGNATION OF LOT MARK	26
10-2	PACKING FORM	27
11	PRECAUTIONS	28
11-1	MOUNTING PRECAUTIONS	28
11-2	OPERATING PRECAUTIONS	28
11-3	ELECTROSTATIC DISCHARGE CONTROL	29
11-4	PRECAUTIONS FOR STRONG LIGHT EXPOSURE	29
11-5	STORAGE	29
11-6	HANDLING PRECAUTIONS FOR PROTECTION FILM	29
11-7	PRECAUTIONS FOR ATTACHING THE TOUCH PANEL PROCESS	29

**Product Specification**

**RECORD OF REVISIONS**

Revision No	Revision Date	Page	Description
0.0	Jan. 08. 2013	-	First Draft, Preliminary Specifications
0.1	Feb. 02. 2013	23	Change front view
		24	Change rear view

Note : This document is preliminary version. The latest version must be checked from LG Display before detail design.

**Product Specification**

**1. Summary**

This module utilizes amorphous silicon thin film transistors and a 4:3 aspect ratio. The 10.4" active matrix liquid crystal display allows 262,144 colors to be displayed by LVDS interface is available.

**2. Features**

- Utilizes a panel with a 4:3 aspect ratio.
- The 10.4" screen produces a high resolution image that is composed of 480,000 pixel elements in a stripe arrangement.
- By adopting Wide viewing angle technology is employed.
- By adopting an active matrix drive, a picture with high contrast is realized.
- By adopting a high aperture panel, high transmittance color filter and high transmission polarizing plates, transmittance ratio is realized.
- Gray scale or the brightness of the sub-pixel color is determined with a 6-bit gray scale signal.
- By adopting LVDS interface, the module has a good performance in terms of EMI.

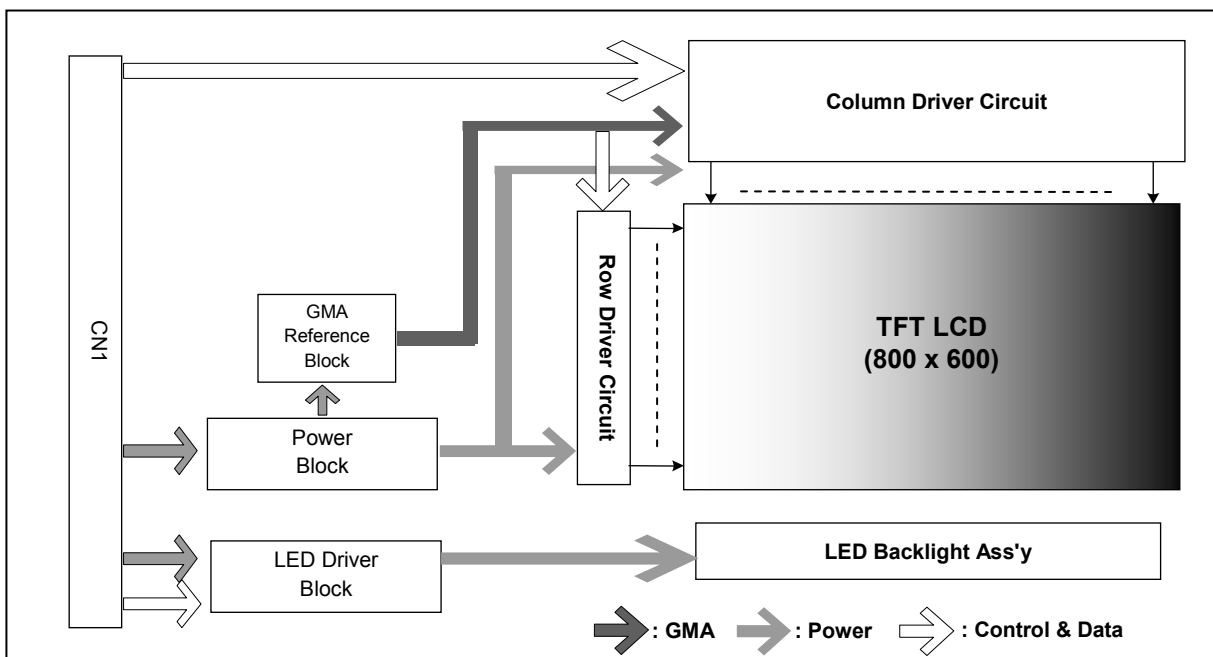

[ Figure 1 ] Block diagram

**Product Specification**

**3.General Features**

Active Screen Size	10.4 inches (264.16mm) diagonal
Outline Dimension	224.5(H) x 172.0(V) x 6.8(D) mm(Typ.)
Pixel Pitch	0.264(H) mm x 0.264(V)mm
Pixel Format	800(H) By 600 (V) Pixels RGB stripes arrangement
Color Depth	6-bit, 262,144 colors
Luminance, White	250 cd/m2(Typ.)
Main Viewing Angle	6 o'clock
Power Consumption	Total 3.2W (Typ.) [Logic= 1.18W, Backlight= 2.02W (BL_DIM=100%)]
Weight	302.5g(Typ.) 317g(MAX)
Display Operating Mode	Transmissive mode, normally white
Surface Treatment	Anti-glare& hard coating(3H)

**Product Specification**

#### 4. Absolute Maximum Ratings

The following are maximum values which, if exceeded, may cause faulty operation or damage to the unit.

**Table 1. ABSOLUTE MAXIMUM RATINGS**

Parameter	Symbol	Values		Units	Notes
		Min	Max		
Power Input Voltage	VCC	-0.3	4.0	Vdc	at 25 ± 5°C
Operating Temperature	TOP	-10	50	°C	1
Storage Temperature	HST	-20	60	°C	1
Operating Ambient Humidity	HOP	10	90	%RH	1
Storage Humidity	HST	10	90	%RH	1

Note : 1. Temperature and relative humidity range are shown in the figure below.  
Wet bulb temperature should be 39°C Max, and no condensation of water.

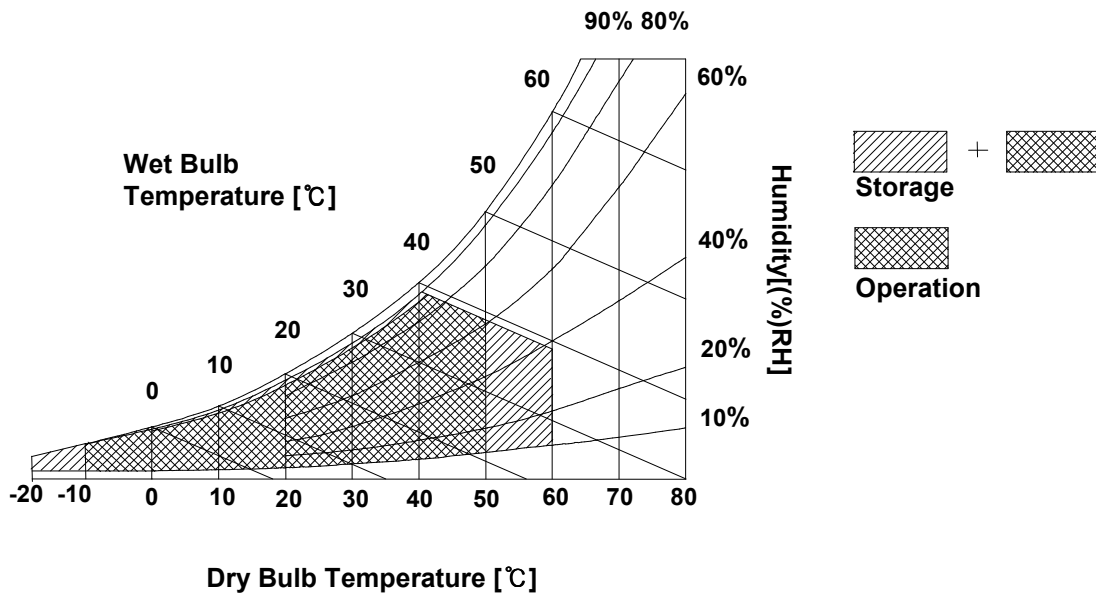

**Product Specification**

**5. Electrical Specifications**

**5-1. Electrical Characteristics**

It requires two power inputs. One is employed to power for the LCD circuit. The other is used for the LED backlight.

**Table 2. LCD DRIVING CIRCUIT ELECTRICAL CHARACTERISTICS**

Parameter	Symbol	Value			Unit	Note	
		Min	Typ	Max			
Power Supply Voltage	V <sub>LCD</sub>	3.0	3.3	3.6	V		
Power Supply Current	Mosaic	I <sub>LCD</sub>	-	280	364	mA	1
	Black	I <sub>LCD</sub>	-	308	400	mA	
Power Consumption	P <sub>LCD</sub>	-	1.02	1.32	Watt		
Rush Current	I <sub>RUSH</sub>	-	-	1.2	A	2	

- Note 1. The specified current and power consumption are under the V<sub>LCD</sub>=3.3V, T<sub>a</sub>=25 ± 2°C, f<sub>v</sub>=60Hz condition whereas mosaic pattern(8 x 6) and white pattern are displayed and f<sub>v</sub> is the frame frequency.
2. The duration of rush current is about 2ms and rising time of power input is 0.5ms (min.). (V<sub>LCD</sub>=3.3V, T<sub>a</sub>=25 ± 2°C, f<sub>v</sub>=60Hz)
3. The recommended operating conditions show the ranges in which the device can operate normally. Operation beyond the limit of the recommended operation conditions is not assured, even though operating conditions are within the limit of the maximum ratings.

White : 63 Gray  
Black : 0 Gray

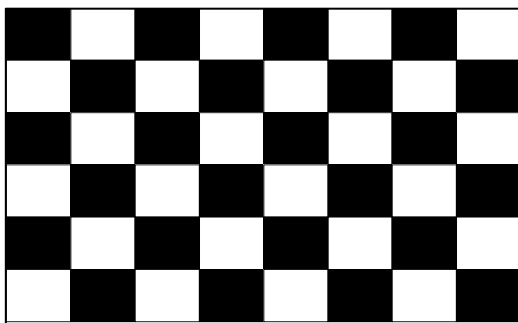

**Mosaic Pattern(8 x 6)**

Black : 0 Gray

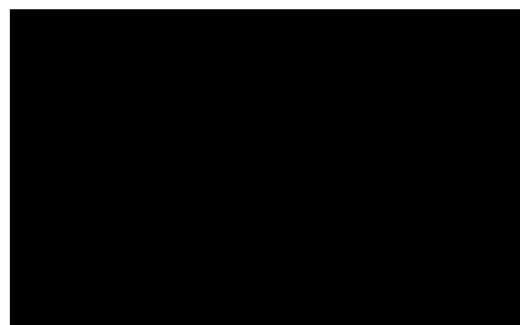

**Black Pattern**

**Product Specification**
**Table 3. BACKLIGHT ELECTRICAL CHARACTERISTICS**

Parameter	Symbol	Values			Unit	Note		
		Min	Typ	Max				
Power Supply Voltage	V <sub>BL</sub>	11	12	12.5	V	1		
Power Supply Current	I <sub>BL</sub>	-	168	218	mA			
Power Consumption	I	-	2.02	2.6	W			
Input & Control Signal	On/Off	On	V <sub>on</sub>	2	-	12	V	
		Off	V <sub>off</sub>	-	0	0.5	V	
	Brightness Adjust	Dimming	10		100	%	On Duty	
	BL_DIM Frequency	F <sub>PWM</sub>	0.5	1	20	KHz	3	
	Pulse Duty Level (BL_DIM)	V <sub>H</sub>	2.7	-	3.3	V	HIGH : on duty LOW : off duty	
V <sub>L</sub>		0.0	-	0.3	V			
Life Time		30,000			Hrs	4		

Note 1. Electrical characteristics are determined after the unit has been 'ON' and stable for approximately 15 minutes at 25±2°C. The specified current and power consumption are under the typical supply input voltage 12V(BL\_DIM=100%), it is total power consumption.

2. The permissible forward current of LED vary with environmental temperature.

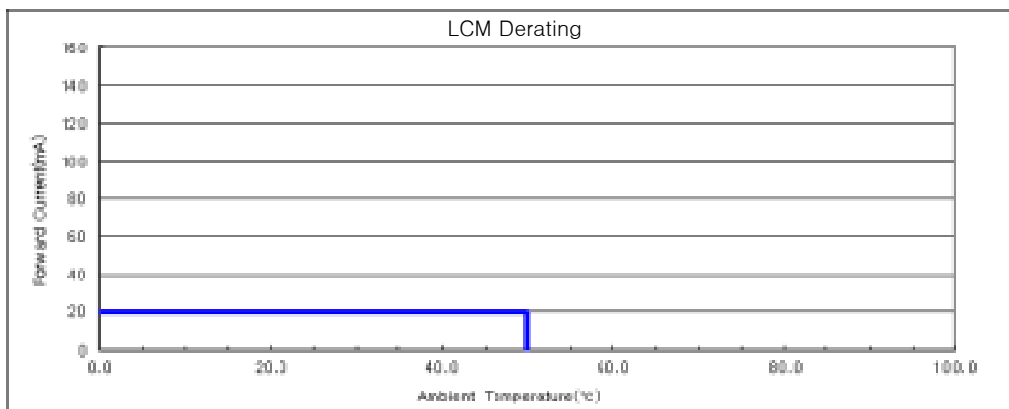
**Ambient Temperature vs. Allowable Forward Current**

3. PWM frequency should be optimized for minimal wavy and audible noise.

4. The life time is determined as the time at which brightness of LED is 50% compare to that of initial value at the typical LED current.



**Product Specification**
**5-2. Interface Connections**

This LCD module employs only one interface connections, 30-pin connector(CN1)

**5-2-1. User Connector(CN1) Pin Configuration**

The electronics interface connector is a model FI-XB30SL-HF10 (Manufactured by JAE)

**Table 4-1. USER CONNECTOR(CN1) PIN CONFIGURATION**

Pin No	Name	I/O	Description	Note
1	VLED	I	Power Supply, 12V Typ.	3
2	VLED	I	Power Supply, 12V Typ.	
3	VLED	I	Power Supply, 12V Typ.	
4	GND	I	Ground	1
5	LED_EN	I	High(Typ.3.3V): Backlight On, Low(0V): Backlight Off	1
6	PWM	I	PWM input for dimming control	
7	TP	I	Test Pin. It should be floating	
8	TP	I	Test Pin. It should be floating	
9	GND	I	Ground	1
10	RAM	I	Negative LVDS differential data input	
11	RAP	I	Positive LVDS differential data input	
12	GND	I	Ground	1
13	RBM	I	Negative LVDS differential data input	
14	RBP	I	Positive LVDS differential data input	
15	GND	I	Ground	1
16	RCM	I	Negative LVDS differential data input	
17	RCP	I	Positive LVDS differential data input	
18	GND	I	Ground	1
19	RCLKM	I	Negative LVDS differential clock input	
20	RCLKP	I	Positive LVDS differential clock input	
21	GND	I	Ground	1
22	NC	-	No Connection	4
23	NC	-	No Connection	4
24	GND	I	Ground	1
25	GND	I	Ground	1
26	TP	I	Test Pin. It should be floating	
27	GND	I	Ground	1
28	GND	I	Ground	
29	VCC	I	Power Supply for module, 3.3V Typ.	2
30	VCC	I	Power Supply for module, 3.3V Typ.	

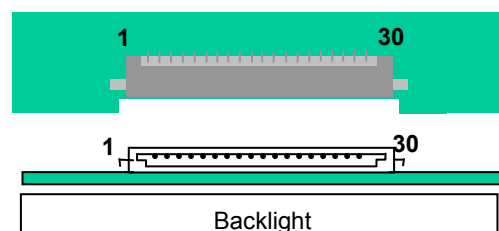
**Rear view of LCM**

**1. Connector**

1.1 LCD : FI-XB30SL-HF10,

**1.2 Mating :**

 FI-XB30SL (Manufactured by JAE) or  
 Equivalent

**Product Specification**

- Note 1. All GND(ground) pins should be connected together.  
2. All VCC pins should be connected together.  
3. All VBL pins should be connected together.  
4. Make sure that NC pins should be floated.

**Product Specification**

**5-2-2. Connection between Host system and LVDS receiver**

If input data is 6bit, connect LSB 2bit of R,G,B to TD0~TD5 pin of LVDS Tx. Refer to FIG 1 for more detail.

**Fig 1. REQUIRED SIGNAL ASSIGNMENT FOR LVDS TRANSMITTER(THC63LVDM83R)**

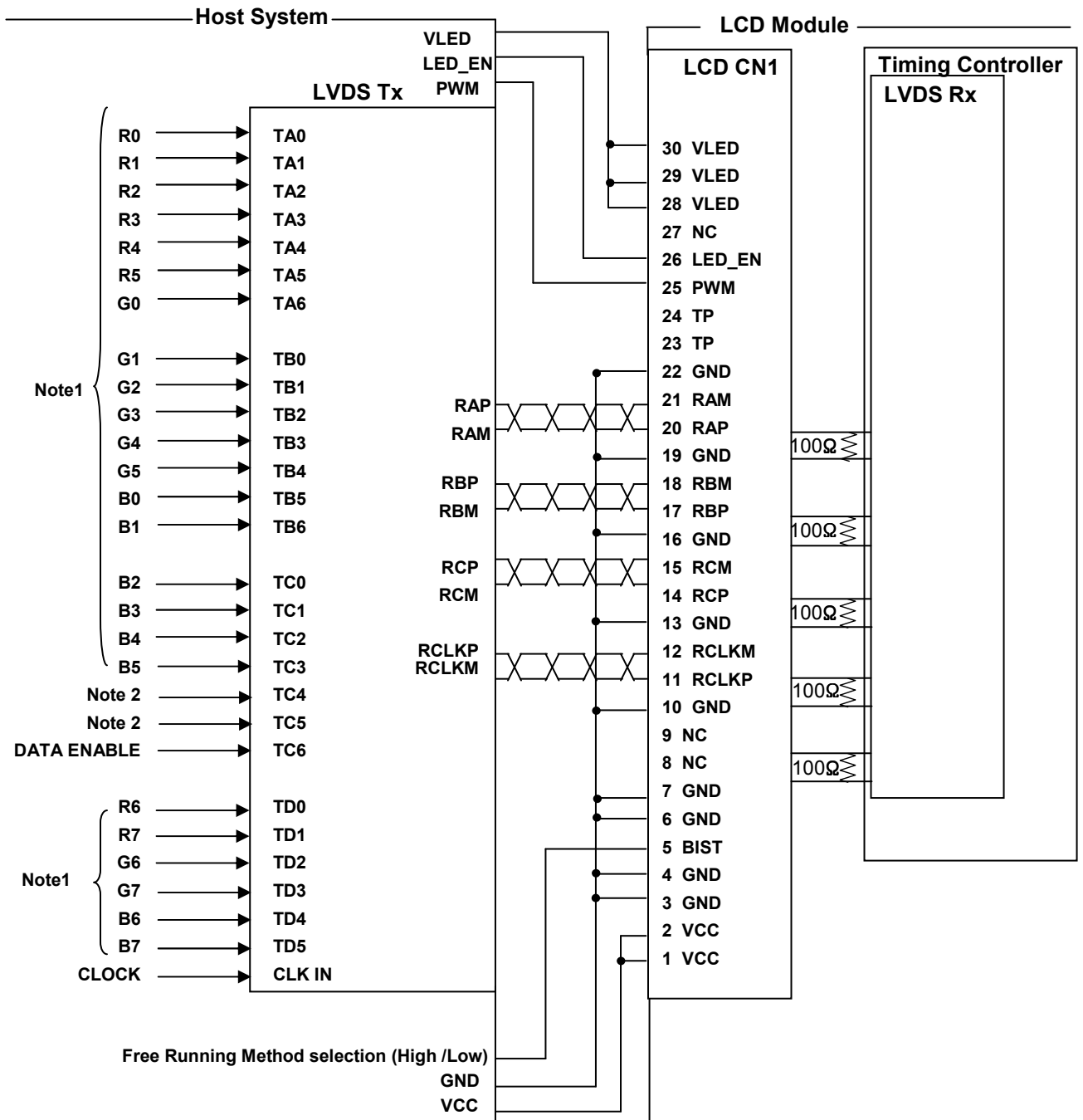

**Product Specification**
**5-3. Signal Timing Specifications**

Table 5 shows the signal timing required at the input of the LVDS transmitter. All of the interface signal timings should be satisfied with the following specification for normal operation.

**Table 5. SIGNAL TIMING CHARACTERISTICS**

ITEM	Symbol		Min	Typ	Max	Unit	Note
DCLK	Period	tCLK	25	25.9	27	ns	
	Frequency	-	37.0	38.5	40.0	MHz	
Hsync	Period	tHP	872	1024	1120	tCLK	
	Width	tWH	12	64	120		
	Horizontal Valid	tHV	800	800	800		
Vsync	Period	tVP	606	625	730	tHP	
	Width	tWV	1	6	24		
	Vertical Valid	tVV	600	600	600		
	Horizontal back porch	tHBP	30	88	120	tCLK	
	Horizontal front porch	tHFP	30	72	80		
	Vertical back porch	tVBP	2	15	22	tHP	
	Vertical front porch	tVFP	3	4	5		

**Note:**

1. DE Only mode operation. The input of Hsync & Vsync signal does not have an effect on LCD normal operation.
2. The performance of the electro-optical characteristics may be influenced by variance of the vertical refresh rates.

Product Specification

5-3-1. Signal Timing Waveforms

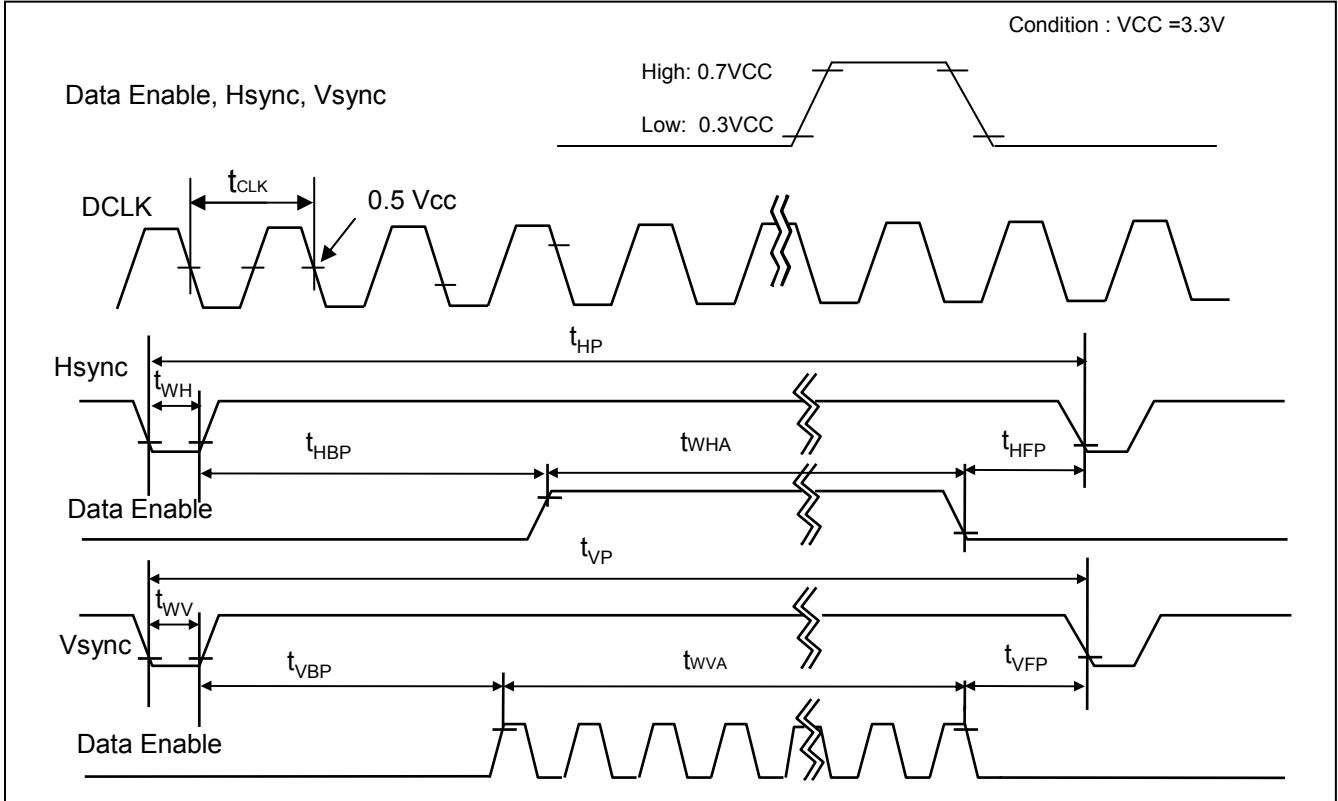

Notes: VCC means logic power voltage. (typ. 3.3V)

Note : This document is preliminary version. The latest version must be checked from LG Display before detail design.

**Product Specification**

**5-4. LVDS Signal Specifications**

**5-4-1. DC Specification**

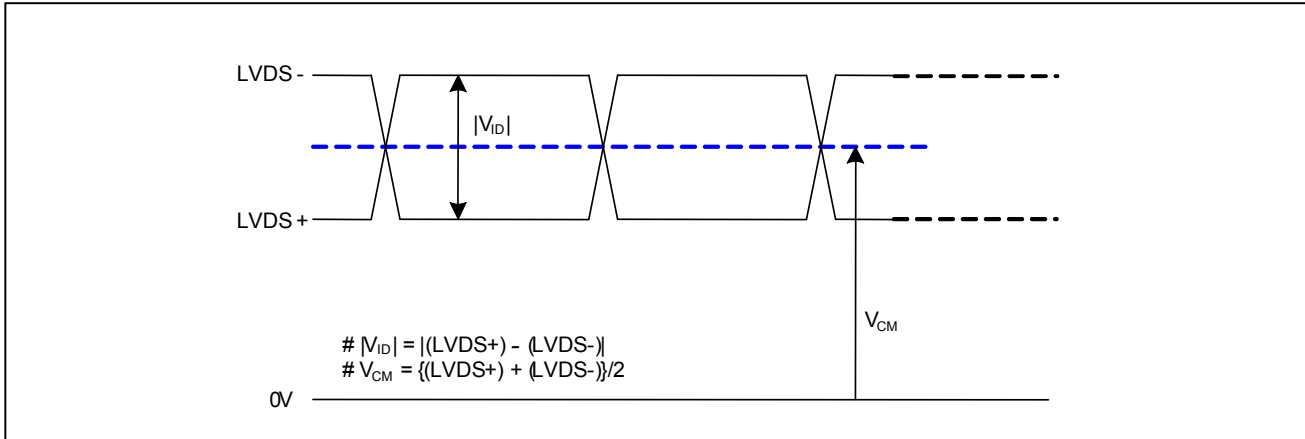

Parameter	Symbol	Min	Typ	Max	Unit	Notes
LVDS Differential Voltage	$ V_{ID} $	200	-	600	mV	-
LVDS Input Common Mode Voltage	$V_{CM}$	$ V_{ID}  / 2$	1.2	$V_{CC} - ( V_{ID} ) / 2$	V	-
Positive-going Input Threshold Voltage	$V_{TH}$	-	-	100	mV	-
Negative-going Input Threshold Voltage	$V_{TL}$	-100	-	-	mV	-

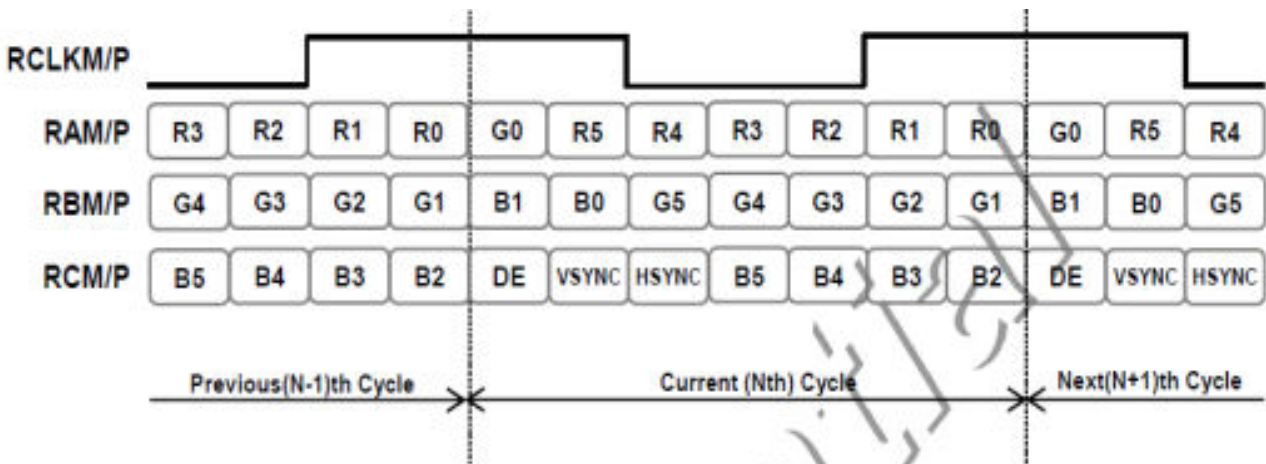

**Product Specification**

**5-4-2. AC Specification**

Parameter	Symbol	Min	Max	Unit	Notes
LVDS Clock to Data Skew Margin	$t_{SKEW}$	-400	+400	ps	$45\text{MHz} > F_{clk} \geq 25\text{MHz}$
Maximum deviation of input clock frequency during SSC	$F_{DEW}$	-	$\pm 3$	%	-
Maximum modulation frequency of input clock during SSC	$F_{MOD}$	-	200	KHz	-

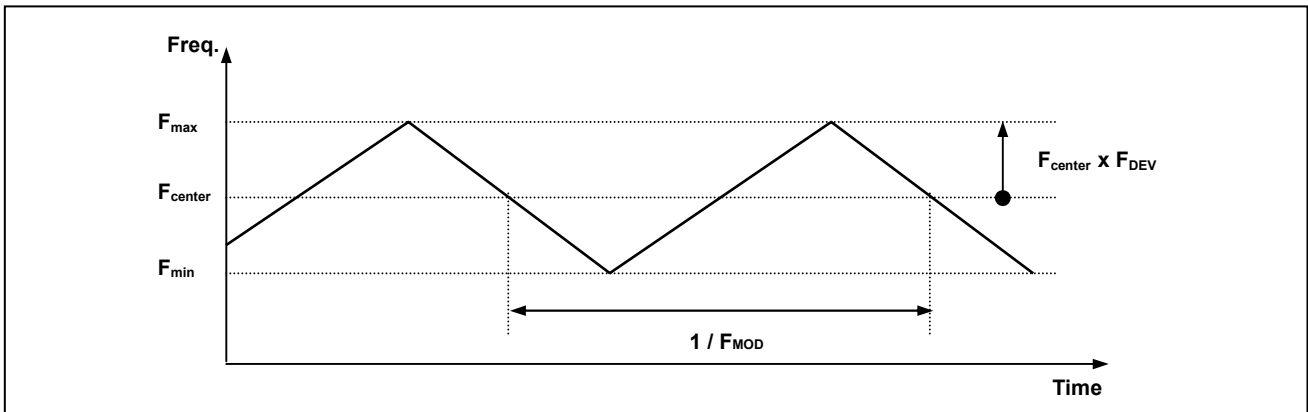
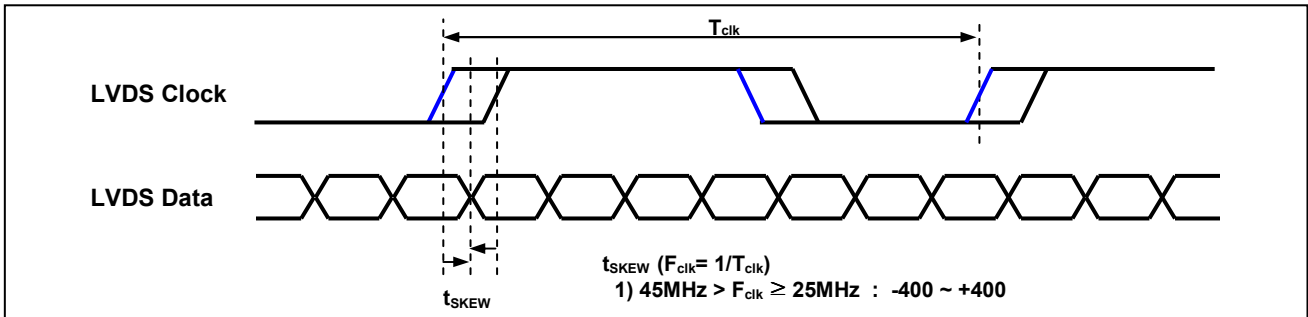

< Spread Spectrum >

Note : This document is preliminary version. The latest version must be checked from LG Display before detail design.

**Product Specification**
**5-5. Color Data Reference**

The brightness of each primary color(red, green, blue) is based on the 6bit gray scale data input for the color. The higher binary input, the brighter the color. Table 6 provides a reference for color versus data input.

**Table 6. COLOR DATA REFERENCE**

Color		Input Color Data																	
		RED						GREEN						BLUE					
		MSB		LSB				MSB		LSB				MSB		LSB			
		R5	R4	R3	R2	R1	R0	G5	G4	G3	G2	G1	G0	B5	B4	B3	B2	B1	B0
Basic Color	Black	0	0	0	0	0	0	0	0	0	0	0	0	0	0	0	0	0	0
	Red (63)	1	1	1	1	1	1	0	0	0	0	0	0	0	0	0	0	0	0
	Green (63)	0	0	0	0	0	0	1	1	1	1	1	1	0	0	0	0	0	0
	Blue (63)	0	0	0	0	0	0	0	0	0	0	0	0	1	1	1	1	1	1
	Cyan	0	0	0	0	0	0	1	1	1	1	1	1	1	1	1	1	1	1
	Magenta	1	1	1	1	1	1	0	0	0	0	0	0	1	1	1	1	1	1
	Yellow	1	1	1	1	1	1	1	1	1	1	1	1	0	0	0	0	0	0
	White	1	1	1	1	1	1	1	1	1	1	1	1	1	1	1	1	1	1
RED	RED (00)	0	0	0	0	0	0	0	0	0	0	0	0	0	0	0	0	0	0
	RED (01)	0	0	0	0	0	1	0	0	0	0	0	0	0	0	0	0	0	0
	...	...						...						...					
	RED (62)	1	1	1	1	1	0	0	0	0	0	0	0	0	0	0	0	0	0
	RED (63)	1	1	1	1	1	1	0	0	0	0	0	0	0	0	0	0	0	0
GREEN	GREEN (00)	0	0	0	0	0	0	0	0	0	0	0	0	0	0	0	0	0	0
	GREEN (01)	0	0	0	0	0	0	0	0	0	0	0	1	0	0	0	0	0	0
	...	...						...						...					
	GREEN (62)	0	0	0	0	0	0	1	1	1	1	1	0	0	0	0	0	0	0
	GREEN (63)	0	0	0	0	0	0	1	1	1	1	1	1	0	0	0	0	0	0
BLUE	BLUE (00)	0	0	0	0	0	0	0	0	0	0	0	0	0	0	0	0	0	0
	BLUE (01)	0	0	0	0	0	0	0	0	0	0	0	0	0	0	0	0	0	1
	...	...						...						...					
	BLUE (62)	0	0	0	0	0	0	0	0	0	0	0	0	1	1	1	1	1	0
	BLUE (63)	0	0	0	0	0	0	0	0	0	0	0	0	1	1	1	1	1	1



**Product Specification**
**5-6. Power Sequence**

For LCD's normal operation, it is recommended to keep below power supply sequence.

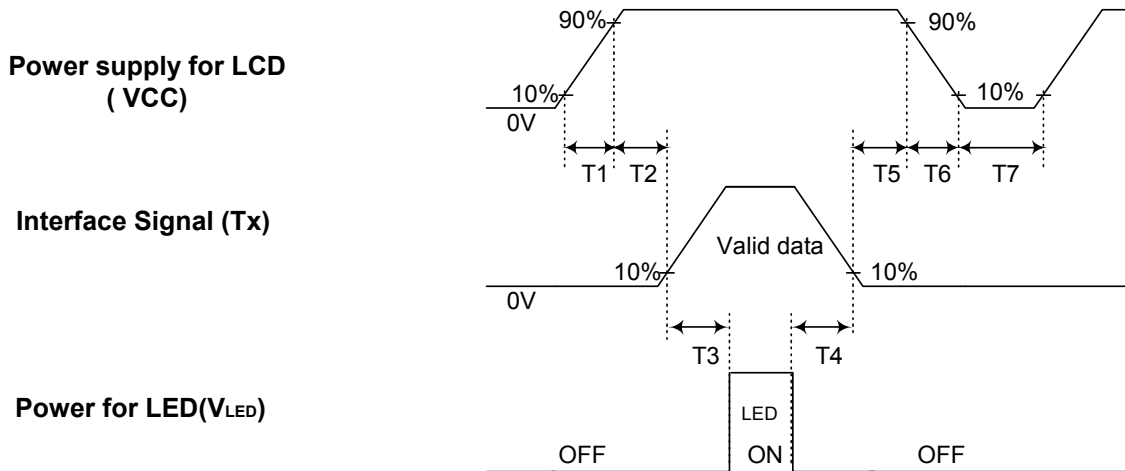

**Table 9. POWER SEQUENCE TABLE**

Parameter	Value			Units
	Min.	Typ.	Max.	
T <sub>1</sub>	-	-	10	(ms)
T <sub>2</sub>	-	-	50	(ms)
T <sub>3</sub>	600	-	-	(ms)
T <sub>4</sub>	200	-	-	(ms)
T <sub>5</sub>	0	-	50	(ms)
T <sub>6</sub>	-	-	10	(ms)
T <sub>7</sub>	1000	-	-	(ms)

Note)

1. Please avoid floating state of interface signal at invalid period.
2. When the interface signal is invalid, be sure to pull down the power supply for LCD VCC to 0V.
3. Lamp power must be turn on after power supply for LCD and interface signal are valid.

**Product Specification**
**6. Electro-optical Characteristics**

Electro-optical characteristics are determined after the unit has been 'ON' and stable in a dark environment at  $25 \pm 2^\circ\text{C}$ . The values are specified at an approximate distance 50cm from the LCD surface at a viewing angle of and equal to  $0^\circ$ . Measured value at the center point of LCD panel after more than 15 minutes while backlight turning on.

It is presented additional information concerning the measurement equipment and method in FIG. 1.

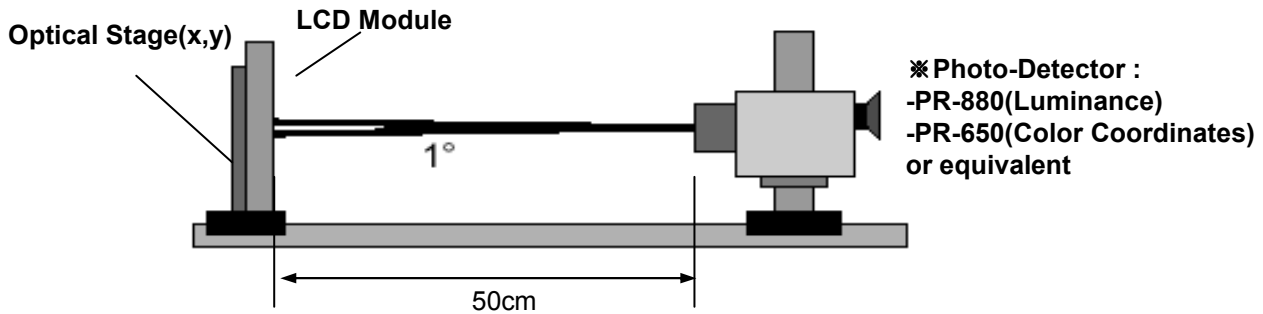
**FIG. 3 Electro-optical Characteristic Measurement Equipment and Method**
**Table 8. ELECTRO-OPTICAL CHARACTERISTICS**
 $T_a = 25 \pm 2^\circ\text{C}$ ,  $V_{CC} = 3.3\text{V}$ ,  $f_v = 60\text{Hz}$ 

Parameter		Symbol	Value			Unit	Note
			Min	Typ	Max		
Contrast Ratio		CR	260	500	-		1
Surface Luminance, white		$L_{WH}$	160	250	-	$\text{cd}/\text{m}^2$	2
Luminance Variation		$\delta_{WHITE}$   9P	80	-	-	%	3
Response Time	Rise Time	$Tr_R$	-	4	7	ms	4
	Decay Time	$Tr_D$	-	6	11	ms	
Color Coordinates [CIE1931]	RED	Rx	Typ -0.03	(0.587)	Typ +0.03		6
		Ry		(0.348)			
	GREEN	Gx		(0.343)			
		Gy		(0.569)			
	BLUE	Bx		(0.158)			
		By		(0.125)			
WHITE	Wx	(0.318)					
	Wy	(0.340)					
Color Gamut			-	45	-	%	
Viewing Angle ( $CR > 10$ )	x axis, right ( $\phi = 0^\circ$ )	$\theta_r$	-	70	-	degree	5
	x axis, left ( $\phi = 180^\circ$ )	$\theta_l$	-	70	-		
	y axis, up ( $\phi = 90^\circ$ )	$\theta_u$	-	55	-		
	y axis, down ( $\phi = 270^\circ$ )	$\theta_d$	-	60	-		
Gray scale				2.2			7

**Product Specification**

Note 1. Contrast Ratio(CR) is defined mathematically as :

$$\text{Contrast Ratio} = \frac{\text{Surface Luminance with all white pixels}}{\text{Surface Luminance with all black pixels}}$$

It is measured at center 1-point.

2. Surface luminance are determined after the unit has been 'ON' and More than 15 Minute after lighting the backlight in a dark environment at  $25 \pm 2^\circ\text{C}$ . Surface luminance is the luminance value at center 1-point across the LCD surface 50cm from the surface with all pixels displaying white. For more information see the FIG. 4.

3. The Luminance Uniformity ( $\delta_{\text{WHITE}}$ ) is determined by measuring LN at each test position 1 through 9. The Luminance Uniformity ( $\delta_{\text{WHITE}}$ ) is defined as follows ;

$$\text{Panel total variation } (\delta_{\text{WHITE}}) = \frac{\text{Minimum}(L1, L2, L3, L4...L9)}{\text{Maximum}(L1, L2, L3, L4...L9)} \times 100\%$$

For more information see the FIG. 4.

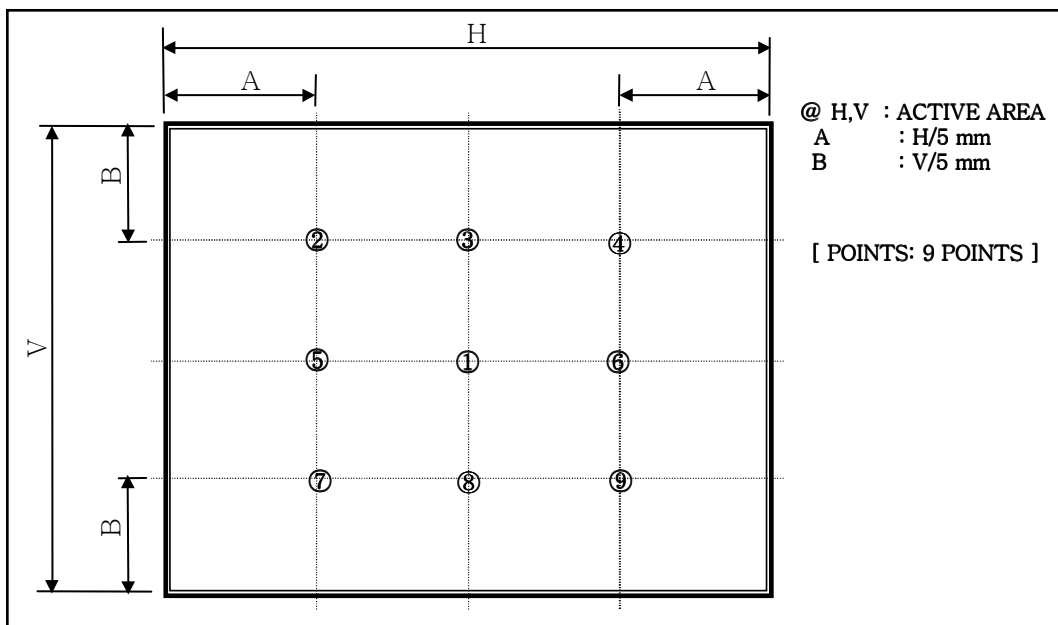

**Product Specification**

Note 4. Response time is obtained by measuring the transition time of photo detector output, when input signals are applied to make center point "black" and "white". For more information, see the FIG. 5.

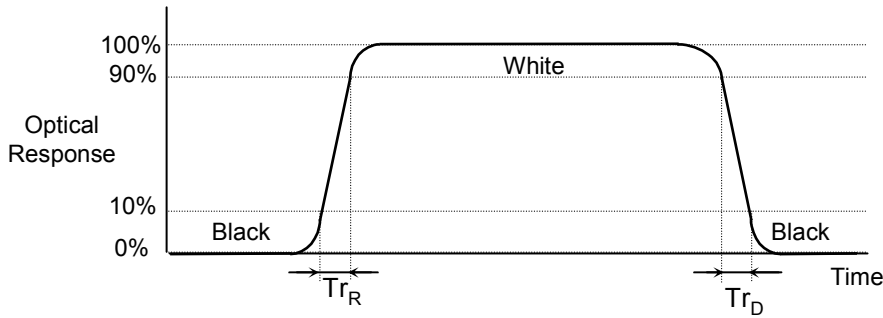

**FIG. 5 Response Time**

5. Viewing angle is the angle at which the contrast ratio is greater than 10. The angles are determined for the horizontal or x axis and the vertical or y axis with respect to the z axis which is normal to the LCD module surface. For more information, see the FIG. 6.

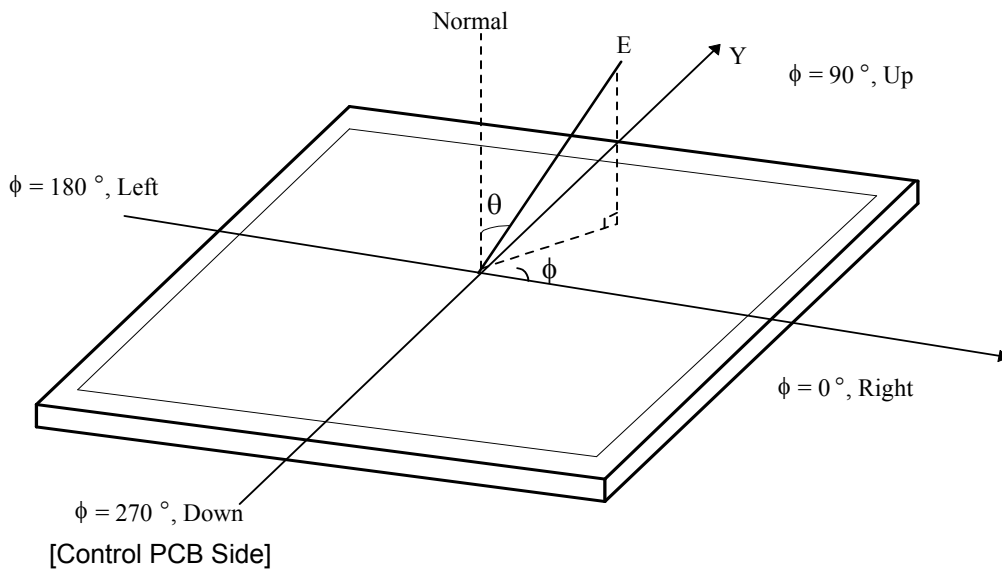

**FIG. 6 Viewing Angle**

6. Please see the Appendix V for more information about Color Coordinator

**Product Specification**

Note 7. Gray scale Specification

<b>Gray Level</b>	<b>Luminance [%] (Typ)</b>
L0	0.14
L3	0.66
L7	1.71
L11	3.01
L15	4.38
L19	6.56
L23	9.36
L27	12.35
L31	16.01
L35	21.56
L39	28.78
L43	37.56
L47	49.45
L51	61.81
L55	74.32
L59	88.23
L63	100

**Product Specification**

**7. Mechanical Characteristics**

The contents provide general mechanical characteristics for this module. In addition the figures in the next page are detailed mechanical drawing of the LCD.

**Table 9. MECHANICAL CHARACTERISTICS**

Parameter	Value	
Outline Dimension	Horizontal	224.5 ± 0.5 mm
	Vertical	172.0 ± 0.5 mm
	Depth	6.8 ± 0.3 mm
Active Display Area	Horizontal	211.2 mm
	Vertical	158.4 mm
Weight	302.5g (Typ.) 317g (Max.)	

Product Specification

<FRONT VIEW>

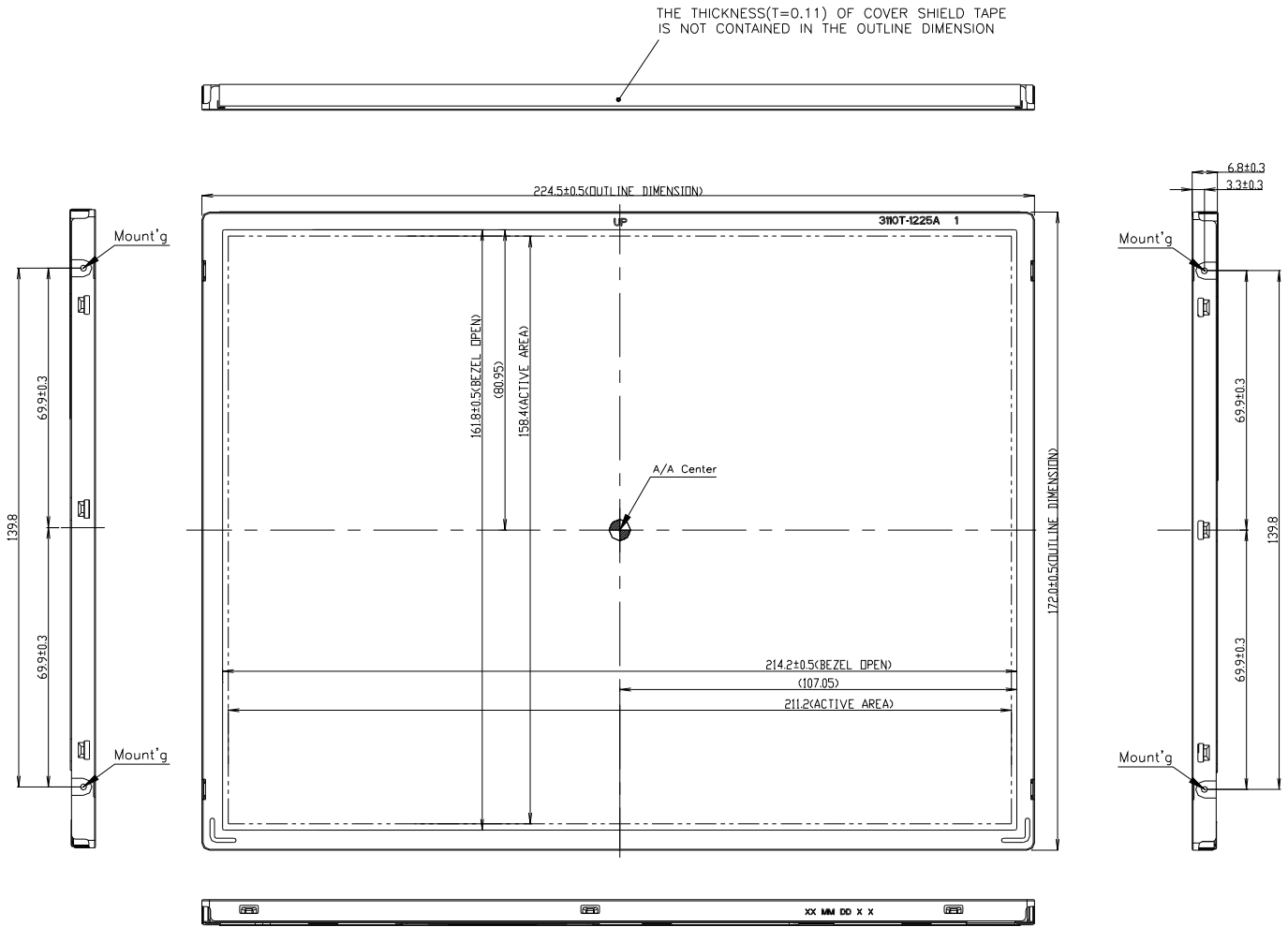

**Product Specification**

**<REAR VIEW>**

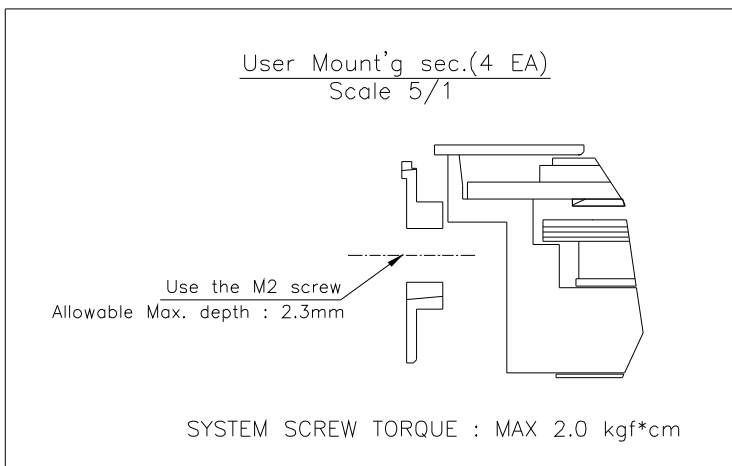
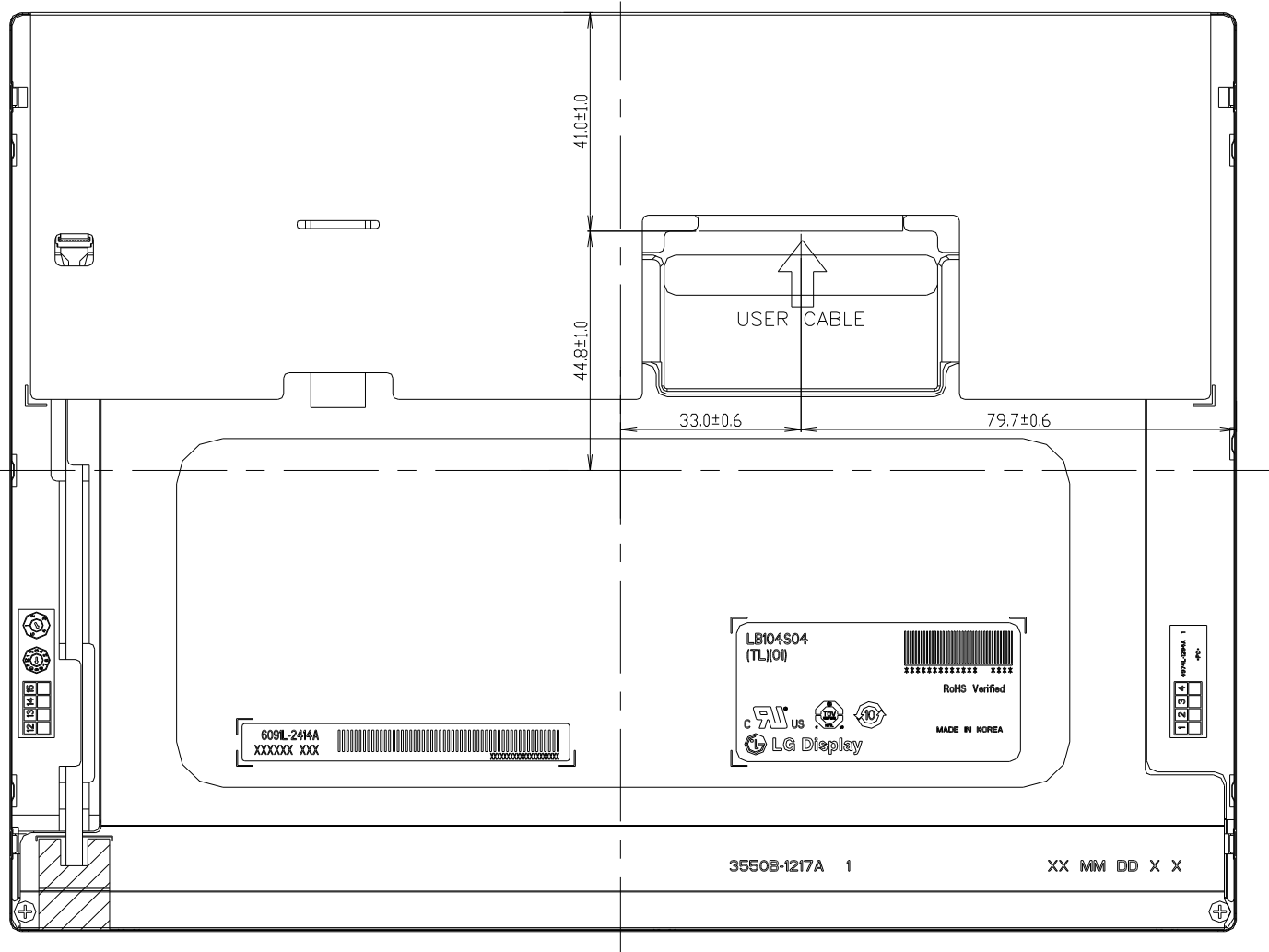



**Product Specification**

**8. Reliability**

**Table 10. ENVIRONMENT TEST CONDITION**

No.	Test Item	Conditions
1	High temperature storage test	Ta= 60°C, 240h
2	Low temperature storage test	Ta= -20°C, 240h
3	High temperature operation test	Ta= 50°C, 50%RH, 240h
4	Low temperature operation test	Ta= -10°C, 240h
5	Vibration test (non-operating)	Random, 10 ~ 300Hz, 0.0035~0.0035G/Hz 1.0Grms, 1 axis, 0.5hour/axis
6	Shock test (non-operating)	Half sine wave, 180G, 2ms one shock of each three faces (I.e. run 180G 6ms for all one faces)
7	Altitude operating storage / shipment	0 ~ 10,000 feet (3,048m) 24Hr 0 ~ 40,000 feet (12,192m) 24Hr

## Product Specification

### 9. International Standards

#### 9-1. Safety

- a) UL 60950-1, Underwriters Laboratories Inc.  
Information Technology Equipment - Safety - Part 1 : General Requirements
- b) CAN/CSA C22.2 No.60950-1-07, Canadian Standards Association.  
Information Technology Equipment - Safety - Part 1 : General Requirements.
- c) EN 60950-1, European Committee for Electrotechnical Standardization (CENELEC).  
Information Technology Equipment - Safety - Part 1 : General Requirements.

#### 9-2. Environment

- a) RoHS, Directive 2002/95/EC of the European Parliament and of the council of 27 January 2003

**Product Specification**

**10. Packing**

**10-1. Designation of Lot Mark**

a) Lot Mark

A	B	C	D	E	F	G	H	I	J	K	L	M
---	---	---	---	---	---	---	---	---	---	---	---	---

A,B,C : SIZE(INCH)  
E : MONTH

D : YEAR  
F ~ M : SERIAL NO.

Note

1. YEAR

Year	2011	2012	2013	2014	2015	2016	2017	2018	2019	2020
Mark	A	B	C	D	E	F	G	H	J	K

2. MONTH

Month	Jan	Feb	Mar	Apr	May	Jun	Jul	Aug	Sep	Oct	Nov	Dec
Mark	1	2	3	4	5	6	7	8	9	A	B	C

b) Location of Lot Mark

Serial No. is printed on the label. The label is attached to the backside of the LCD module.  
This is subject to change without prior notice.

**Product Specification**

**10-2. Packing Form**

- a) Package quantity in one box : 15 pcs
- b) Box Size :L425mm X W246mm X H287mm

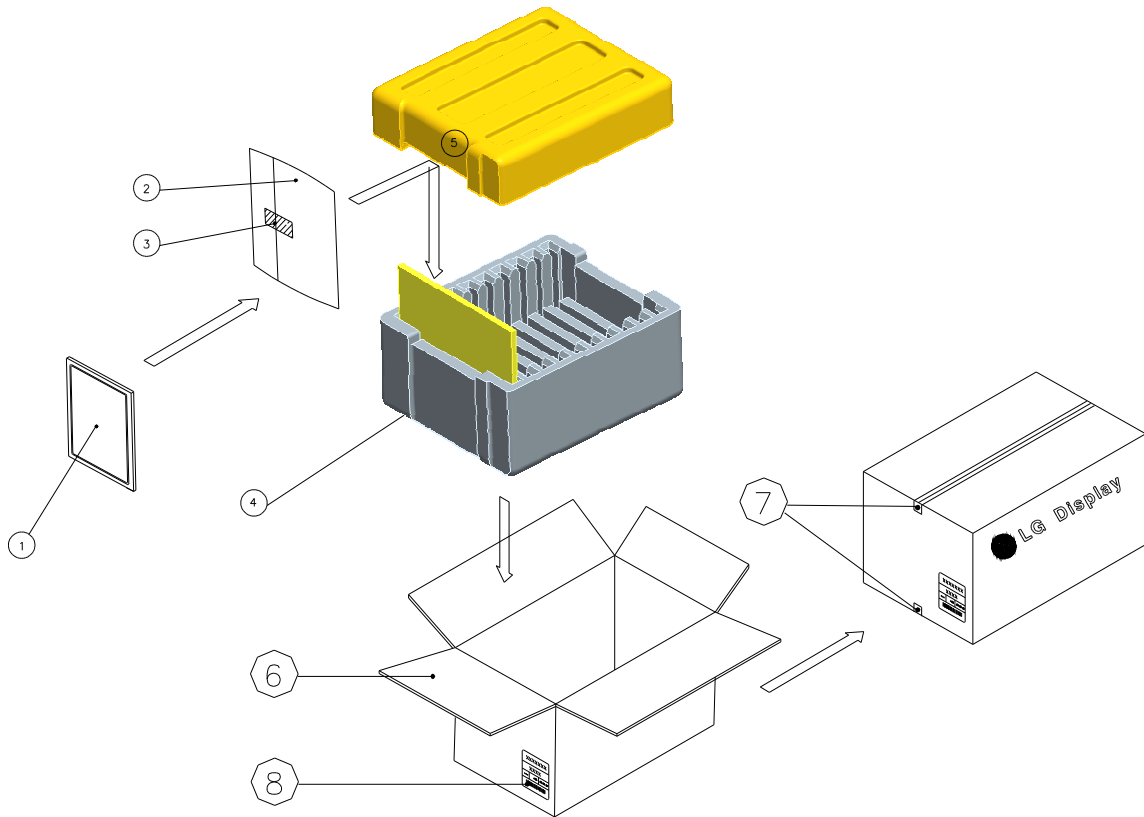

NO.	Description	Material
1	Module	15 pcs / 1box
2	Bag	PE
3	Tape	MASKING TAPE
4	Packing, Bottom	EPS
5	Packing, Top	EPS
6	Carton Box	SWR4
7	Tape	OPP 70MMx300m
8	Label	YUPO Paper 100x70

## Product Specification

### 11. PRECAUTIONS

Please pay attention to the following when you use this TFT LCD module.

#### 11-1. MOUNTING PRECAUTIONS

- (1) You must mount a module using specified mounting structure. (Details refer to the drawings)
- (2) You should consider the mounting structure so that uneven force(ex. Twisted stress) is not applied to the module.  
And the case on which a module is mounted should have sufficient strength so that external force is not transmitted directly to the module.
- (3) Please attach a transparent protective plate to the surface in order to protect the polarizer.  
Transparent protective plate should have sufficient strength in order to resist external force.
- (4) You should adopt radiation structure to satisfy the temperature specification.
- (5) Acetic acid type and chlorine type materials for the cover case are not desirable because the former generates corrosive gas of attacking the polarizer at high temperature and the latter causes circuit break by electro-chemical reaction.
- (6) Do not touch, push or rub the exposed polarizers with glass, tweezers or anything harder than HB pencil lead. And please do not rub with dust clothes with chemical treatment.  
Do not touch the surface of polarizer for bare hand or greasy cloth.(Some cosmetics deteriorate the polarizer.)
- (7) When the surface becomes dusty, please wipe gently with absorbent cotton or other soft materials like chamois soaks with petroleum benzine. Normal-hexane is recommended for cleaning the adhesives used to attach front / rear polarizers. Do not use acetone, toluene and alcohol because they cause chemical damage to the polarizer.
- (8) Wipe off saliva or water drops as soon as possible. Their long time contact with polarizer causes deformations and color fading.
- (9) Do not open the case because inside circuits do not have sufficient strength.
- (10) The metal case of a module should be contacted to electrical ground of your system.

#### 11-2. OPERATING PRECAUTIONS

- (1) The spike noise causes the mis-operation of circuits. It should be lower than following voltage :  
 $V = \pm 200\text{mV}$  (Over and under shoot voltage)
- (2) Response time depends on the temperature. (In lower temperature, it becomes longer.)
- (3) Brightness depends on the temperature. (In higher temperature, it becomes lower.)
- (4) Be careful for condensation at sudden temperature change. Condensation makes damage to polarizer or electrical contacted parts. And after fading condensation, smear or spot will occur.
- (5) When fixed patterns are displayed for a long time, remnant image is likely to occur.
- (6) Module has high frequency circuits. Sufficient suppression to the electromagnetic interference shall be done by system manufacturers. Grounding and shielding methods may be important to minimize the interference.

## Product Specification

### 11-3. ELECTROSTATIC DISCHARGE CONTROL

Since a module is composed of electronic circuits, it is not strong to electrostatic discharge. Make certain that treatment persons are connected to ground through wrist band etc. And don't touch interface pin directly.

### 11-4. PRECAUTIONS FOR STRONG LIGHT EXPOSURE

Strong light exposure causes degradation of polarizer and color filter.

### 11-5. STORAGE

When storing modules as spares for a long time, the following precautions are necessary.

- (1) Store them in a dark place. Do not expose the module to sunlight or fluorescent light. Keep the temperature between 5°C and 35°C at normal humidity.
- (2) The polarizer surface should not come in contact with any other object.  
It is recommended that they be stored in the container in which they were shipped.

### 11-6. HANDLING PRECAUTIONS FOR PROTECTION FILM

- (1) The protection film is attached to the bezel with a small masking tape or a double side tape.  
When the protection film is peeled off, static electricity is generated between the film and polarizer.  
This should be peeled off slowly and carefully by people who are electrically grounded and with well ion-blown equipment or in such a condition, etc.
- (2) When the module with protection film attached is stored for a long time, sometimes there remains a very small amount of glue still on the bezel after the protection film is peeled off.
- (3) You can remove the glue easily. When the glue remains on the bezel surface or its vestige is recognized, please wipe them off with absorbent cotton waste or other soft material like chamois soaked with normal-hexane.

### 11-7. PRECAUTIONS FOR ATTACHING THE TOUCH PANEL PROCESS

- (1) When being touch panel laminate, Stems, Scratch, Stain and etc. can be occurred and then the operation should be with care. After being attached touch panel, It is not warranty for quality problems