



SANYO Semiconductors

DATA SHEET

An ON Semiconductor Company

Monolithic Digital IC

LB11660FV — Single-Phase Full-Wave Fan Motor Driver

Overview

The LB11660FV is a single-phase bipolar drive half-predriver motor driver that can easily implement a direct PWM driver motor driver circuit with excellent efficiency. The LB11660FV is particularly well suited for the miniature fans used in servers.

Features

- Single-phase full-wave drive (15V, 1.5A transistors are built in)
Half predriver with integrated high side transistor
- Built-in variable speed function controlled by an external input
The LB11660FV can implement quiet, low-vibration variable speed control using externally clocked high side transistor direct PWM drive.
- Minimum speed setting pin
- Current limiter circuit (The limit value is determined by R_f ; $I_O = 1A$ when $R_F = 0.5\Omega$)
- Built-in kickback absorption circuit
- Soft switching circuit makes low current consumption, low loss, and low noise drive possible at phase switching
- Built-in HB
- Built-in lock protection and automatic recovery circuits (built-in on/off ratio switching circuit controlled by the supply voltage)
- FG (speed detection) output
- Built-in thermal protection circuit (design guarantee)

■ Any and all SANYO Semiconductor Co.,Ltd. products described or contained herein are, with regard to "standard application", intended for the use as general electronics equipment (home appliances, AV equipment, communication device, office equipment, industrial equipment etc.). The products mentioned herein shall not be intended for use for any "special application" (medical equipment whose purpose is to sustain life, aerospace instrument, nuclear control device, burning appliances, transportation machine, traffic signal system, safety equipment etc.) that shall require extremely high level of reliability and can directly threaten human lives in case of failure or malfunction of the product or may cause harm to human bodies, nor shall they grant any guarantee thereof. If you should intend to use our products for applications outside the standard applications of our customer who is considering such use and/or outside the scope of our intended standard applications, please consult with us prior to the intended use. If there is no consultation or inquiry before the intended use, our customer shall be solely responsible for the use.

■ Specifications of any and all SANYO Semiconductor Co.,Ltd. products described or contained herein stipulate the performance, characteristics, and functions of the described products in the independent state, and are not guarantees of the performance, characteristics, and functions of the described products as mounted in the customer's products or equipment. To verify symptoms and states that cannot be evaluated in an independent device, the customer should always evaluate and test devices mounted in the customer's products or equipment.

LB11660FV

Specifications

Absolute Maximum Ratings at $T_a = 25^\circ\text{C}$

Parameter	Symbol	Conditions	Ratings	Unit
V_{CC} maximum supply voltage	V_{CC} max		20	V
V_M maximum supply voltage	V_M max		20	V
OUT pin maximum output current	I_{OUT} max	$R_f \geq 0.39\Omega$	1.5	A
OUT pin output voltage 1	V_{OUT} max 1		20	V
OUT pin output voltage 2	V_{OUT} max 2	$T \leq 0.4\mu\text{s}$	26.5	V
PRE pin maximum source current	I_{PSO} max		30	mA
PRE pin maximum sink current	I_{PSI} max		-7	mA
PRE pin output voltage	V_P max		20	V
HB maximum output current	I_{HB} max		10	mA
VTH input pin voltage	V_{TH} max		7	V
FG output pin voltage	V_{FG} max		18	V
FG output current	I_{FG} max		10	mA
Allowable power dissipation	P_d max	When mounted on a circuit board *1	0.8	W
Operating temperature	T_{opr}	*2	-30 to +90	$^\circ\text{C}$
Storage temperature	T_{stg}		-55 to +150	$^\circ\text{C}$

*1 Specified circuit board : $114.3 \times 76.1 \times 1.6\text{mm}^3$, glass epoxy.

*2: T_j max is 150°C . This device must be used under conditions such that the chip temperature does not exceed $T_j = 150^\circ\text{C}$ during operation.

Recommended Operating Conditions at $T_a = 25^\circ\text{C}$

Parameter	Symbol	Conditions	Ratings	Unit
V_{CC} supply voltage	V_{CC}		4 to 15	V
V_M supply voltage	V_M		3 to 15	V
Current limiter operation range	I_{LIM}		0.6 to 1.2	V
VTH input level voltage range	V_{TH}		0 to 6	V
Hall sensor input common-mode input voltage range	V_{ICM}		0.2 to 3	V

Electrical Characteristics Unless otherwise specified $T_a = 25^\circ\text{C}$, $V_{CC} = 12\text{V}$

Parameter	Symbol	Conditions	Ratings			Unit
			min	typ	max	
Circuit current	I_{CC1}	Drive mode		9	12	mA
HB voltage	V_{HB}	$I_{HB} = 5\text{mA}$	1.05	1.25	1.40	V
6VREG voltage	V_{6VREG}	$6VREG = 5\text{mA}$	5.80	6	6.20	V
CT pin high-level voltage	V_{CTH}		3.4	3.6	3.8	V
CT pin low-level voltage	V_{CTL}		1.4	1.6	1.8	V
ICT pin charge current 1	I_{CTC1}	$V_{CC} = 12\text{V}$	1.7	2.2	2.7	μA
ICT pin charge current 2	I_{CTC2}	$V_{CC} = 6\text{V}$	1.3	1.8	2.3	μA
ICT pin discharge current 1	I_{CTD1}	$V_{CC} = 12\text{V}$	0.11	0.15	0.19	μA
ICT pin discharge current 2	I_{CTD2}	$V_{CC} = 6\text{V}$	0.34	0.44	0.54	μA
ICT charge/discharge current ratio 1	R_{CT1}	$V_{CC} = 12\text{V}$	12	15	18	Times
ICT charge/discharge current ratio 2	R_{CT2}	$V_{CC} = 6\text{V}$	3	4	5	Times
ICT charge/discharge ratio threshold voltage	V_{RCT}		6	6.6	7.3	V
VTH bias current	I_{BVTH}		-2	-1	0	μA
OUT output high saturation voltage	V_{OH}	$I_O = 200\text{mA}$, $R_L = 1\Omega$		0.6	0.8	V

Continued on next page.

LB11660FV

Continued from preceding page.

Parameter	Symbol	Conditions	Ratings			Unit
			min	typ	max	
PRE output low saturation voltage	V _{PL}	I _O = 5mA		0.2	0.4	V
PRE output high saturation voltage	V _{PH}	I _O = -20mA		0.9	1.2	V
Current limiter	VR _f	V _{CC} - VM	450	500	550	mV
PWM output pin high-level voltage	VPWMH		2.2	2.5	2.8	V
PWM output pin low-level voltage	VPWML		0.4	0.5	0.7	V
PWM external C charge current	IPWM1		-23	-18	-14	μA
PWM external C discharge current	IPWM2		18	24	30	μA
PWM oscillator frequency	FPWM	C = 200pF	19	23	27	kHz
Hall sensor input sensitivity	VHN	Zero peak value (including offset and hysteresis)		15	25	mV
FG output pin low-level voltage	VFG/RD	IFG/RD = 5mA		0.2	0.3	V
FG output pin leakage current	IFGL/IRDL	VFG/RD = 7V			30	μA
Thermal protection circuit	THD	Design target value*3	150	180	210	°C

*3: This is a design guarantee and is not tested in individual units. The thermal protection circuit is included to prevent any thermal damage to the IC. Since this would imply operation outside the IC's guaranteed temperature range, the application thermal design must be such that the thermal protection circuit will not operate if the fan is operating constantly.

Package Dimensions

unit : mm (typ)

3178B

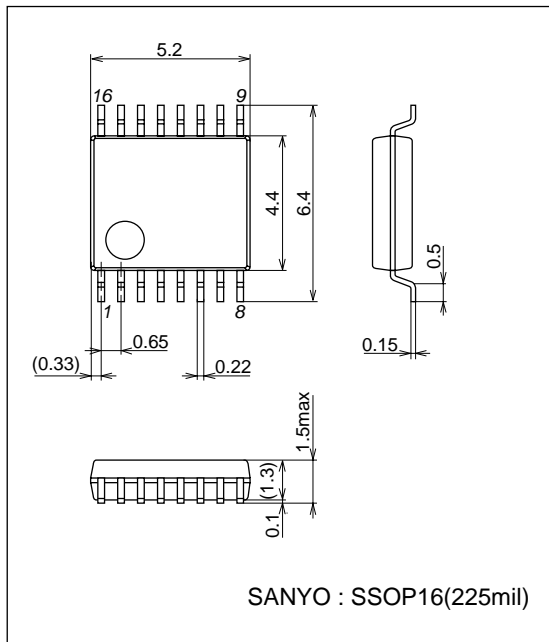

Pin Assignment

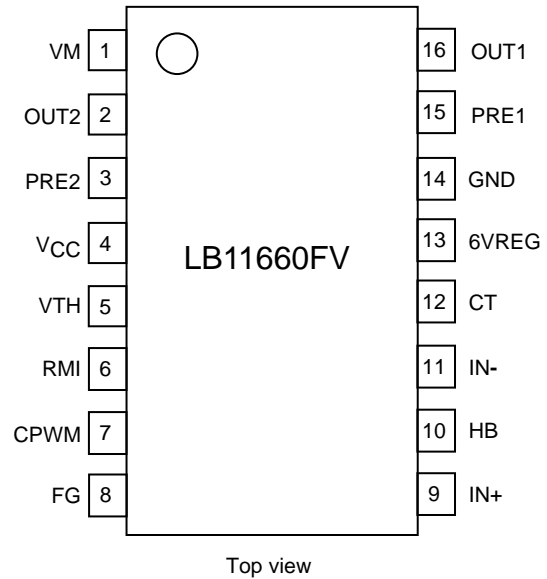

Truth Table

IN-	IN+	VTH	CPWM	CT	OUT1	OUT2	PRE1	PRE2	FG	Mode
High	Low	Low	High	Low	High	Off	Low	High	Low	During rotation – drive
Low	High				Off	High	High	Low	Off	
High	Low	High	Low		Off	Off	Low	High	Low	During rotation – regeneration
Low	High				Off	Off	High	Low	Off	
High	Low	-	-	High	Off	Off	Low	High	Low	Lock protection
Low	High				Off	Off	High	Low	Off	

CPWM – High is the state where CPWM > VTH, and CPWM– Low is the state where CPWM < VTH.

Application Circuit Example 1

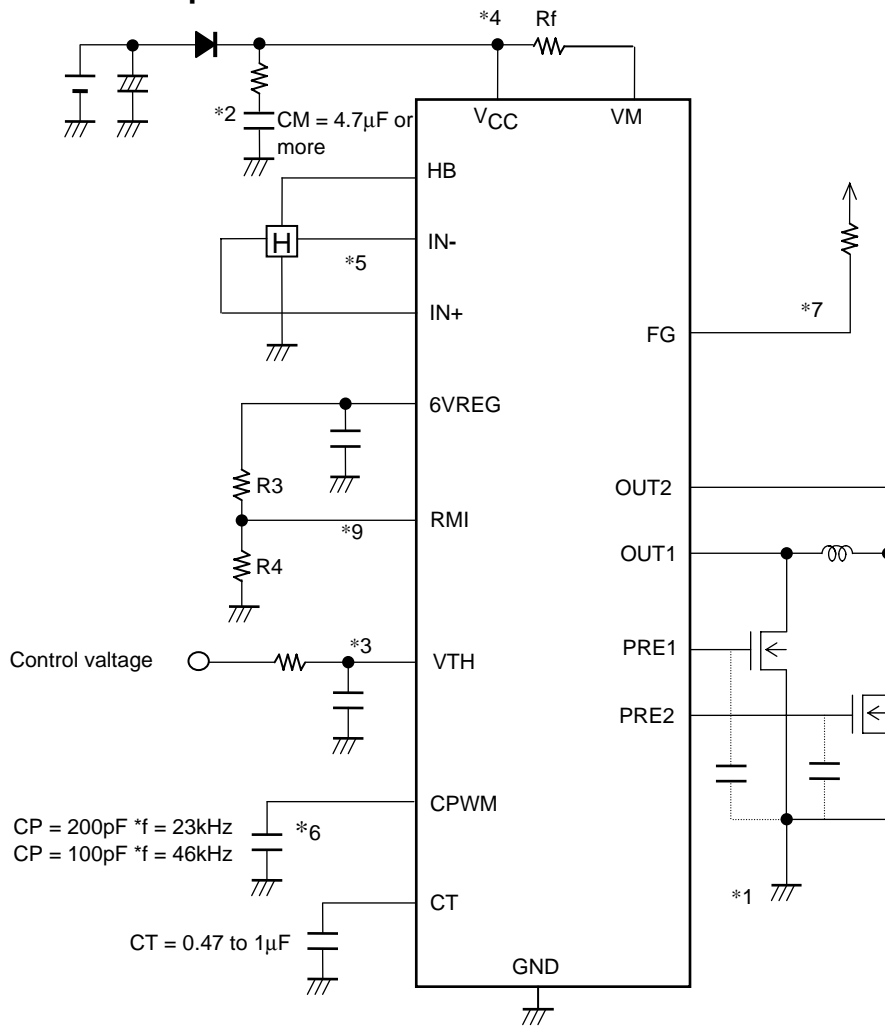

***1. Power supply and ground lines**

The IC ground is the control current power supply system ground, and the external n-channel transistor ground is the motor power supply system ground. These two systems should be formed from separate lines and the control system external components should be connected to the IC ground.

***2. Regeneration power supply stabilization capacitor**

Use a 4.7μF/25V capacitor at least for CM, which is the power supply stabilization capacitor for both PWM drive and kickback absorption.

The capacitor CM must be connected to prevent destruction of the IC when power is applied or removed.

***3. Speed Control**

(1) Control voltage

The PWM duty is determined by comparing the VTH pin voltage with the PWM oscillator waveform.

When the VTH voltage falls, the on duty increases and when the VTH voltage falls below the PWM output low level, the duty will go to 100%.

(2) Thermistor

For thermistor applications, normally the 6VREG level will be resistor divided and the divided level input to the VTH pin.

The PWM duty is changed by changes in the VTH pin voltage due to changes in temperature.

***4. Current limiter setting**

The current limiter circuit operates if the voltage across the resistor between VCC and the VM pin exceeds 0.5V.

Since the current limiter circuit applies limitation at a current determined by $I_O = VRf/Rf$ (where $VRf = 0.5V$ (typical), Rf : resistance of the current detection resistor), the current limiter will operate at $I_O = 1A$ when $Rf = 0.5\Omega$.

The resistor Rf must be connected in the circuit and it must have a value such that the circuit operates within the recommended current limiter operating range.

***5. Hall sensor input**

Lines that are as short as possible must be used to prevent noise from entering the system. The Hall sensor input circuit consists of a comparator with hysteresis (20mV). We recommend that the Hall sensor input level be at least three times this hysteresis, i.e. at least 60mVp-p.

***6. PWM oscillator frequency setting capacitor**

The PWM oscillator oscillates at $f = 23\text{kHz}$ when CP is 200pF and at $f = 46\text{kHz}$ when CP is 100pF, and this frequency becomes the PWM reference frequency.

Note that the PWM frequency is given approximately by the following equation.

$$f \text{ [kHz]} \approx (4.6 \times 10^6) \div C \text{ [pF]}$$

***7. FG output**

This is an open collector output, and a rotation count detection function can be implemented using this FG output, which corresponds to the phase switching. This pin must be left open if unused.

***8. HB pin**

This pin provides a Hall effect sensor bias constant-voltage output of 1.25V.

***9. RMI pin**

This pin is the speed control minimum speed setting.

The minimum output duty is set by R3 and R4. Leave R4 open to have the motor stop when the duty is 0%.

Rotation Control Timing Chart

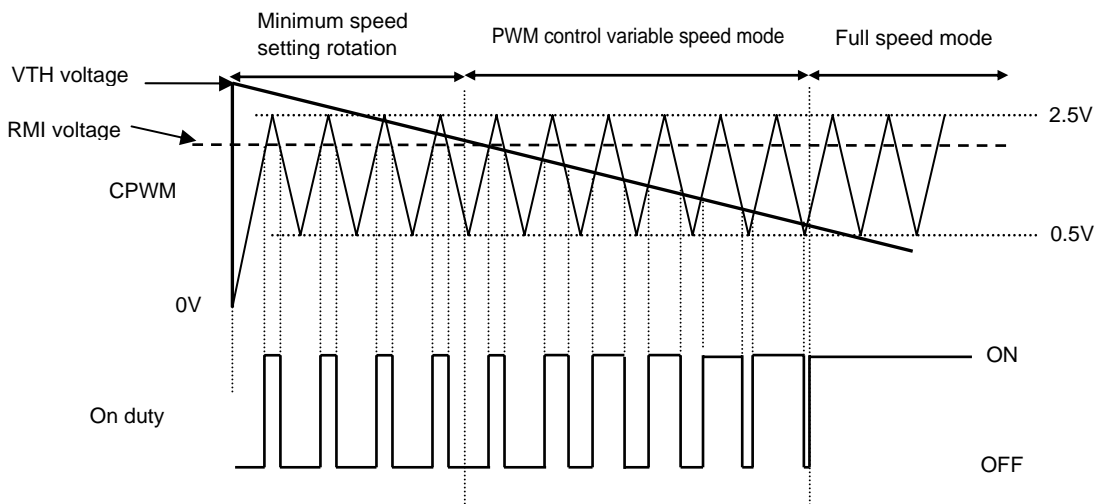
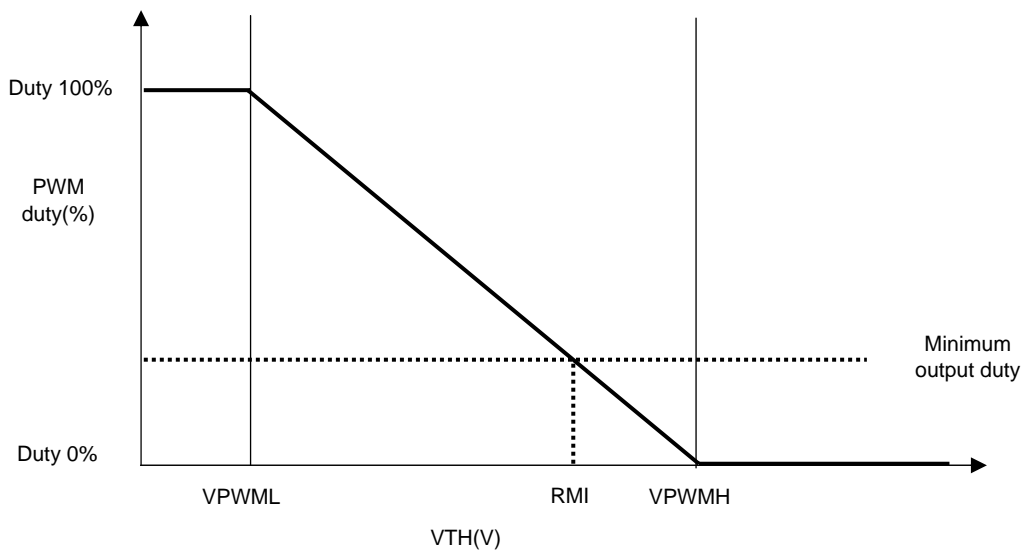

Application Circuit Example 2

SANYO mounting circuit board (Component values are provided for reference purposes)

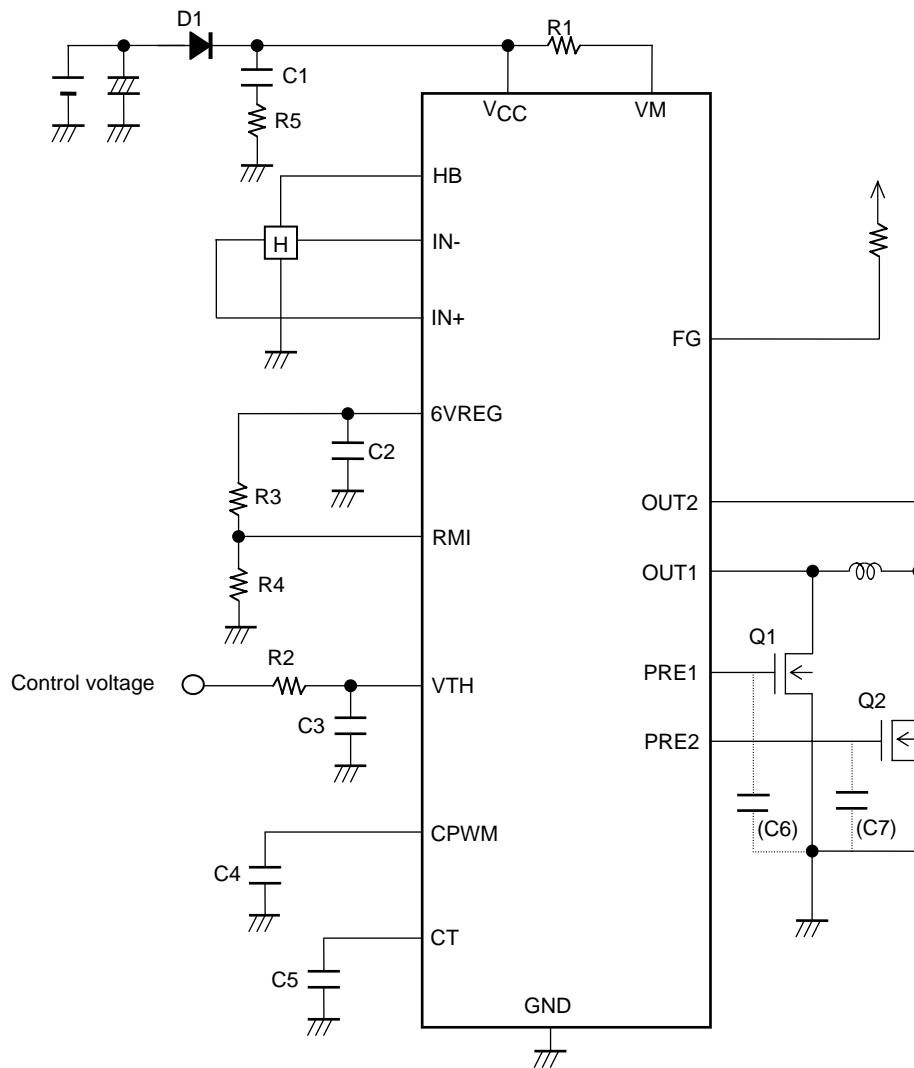

Parts List

- D1 : SBM30-03-Tr (SANYO)
- Q1, 2 : CPH3418 (SANYO)
- R1 : 0.51Ω size 3225
- R2 : 15kΩ size 1608
- R3 : 39kΩ size 1608
- R4 : 20kΩ size 1608
- R5 : 2.2Ω size 1608
- C1 : 4.7μF/25V size 3216
- C2 : 2.2μF size 1608
- C3 : 2.2μF size 1608
- C4 : 220pF size 1005
- C5 : 0.47μF size 1608
- C6, 7 : No connection

Application Circuit Example 3

No minimum speed setting, thermistor input used

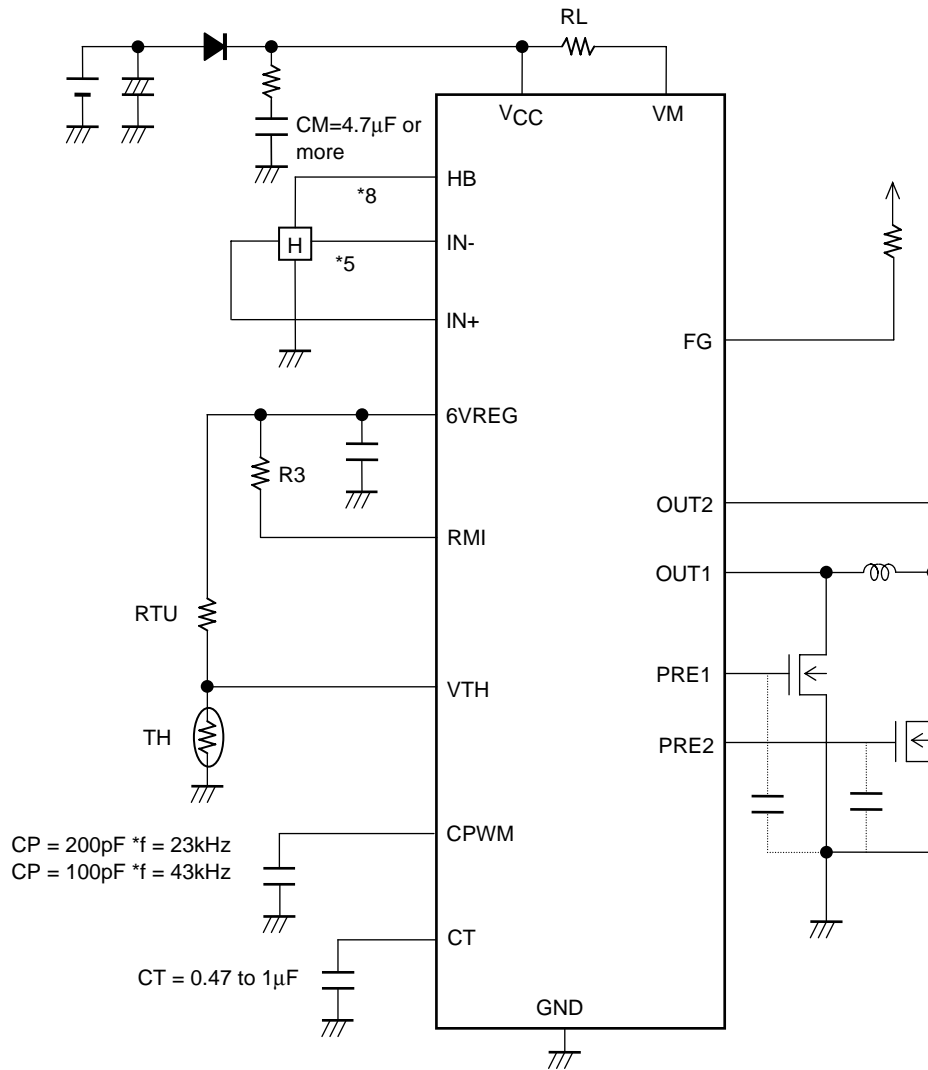

Internal Equivalent Circuit Diagram

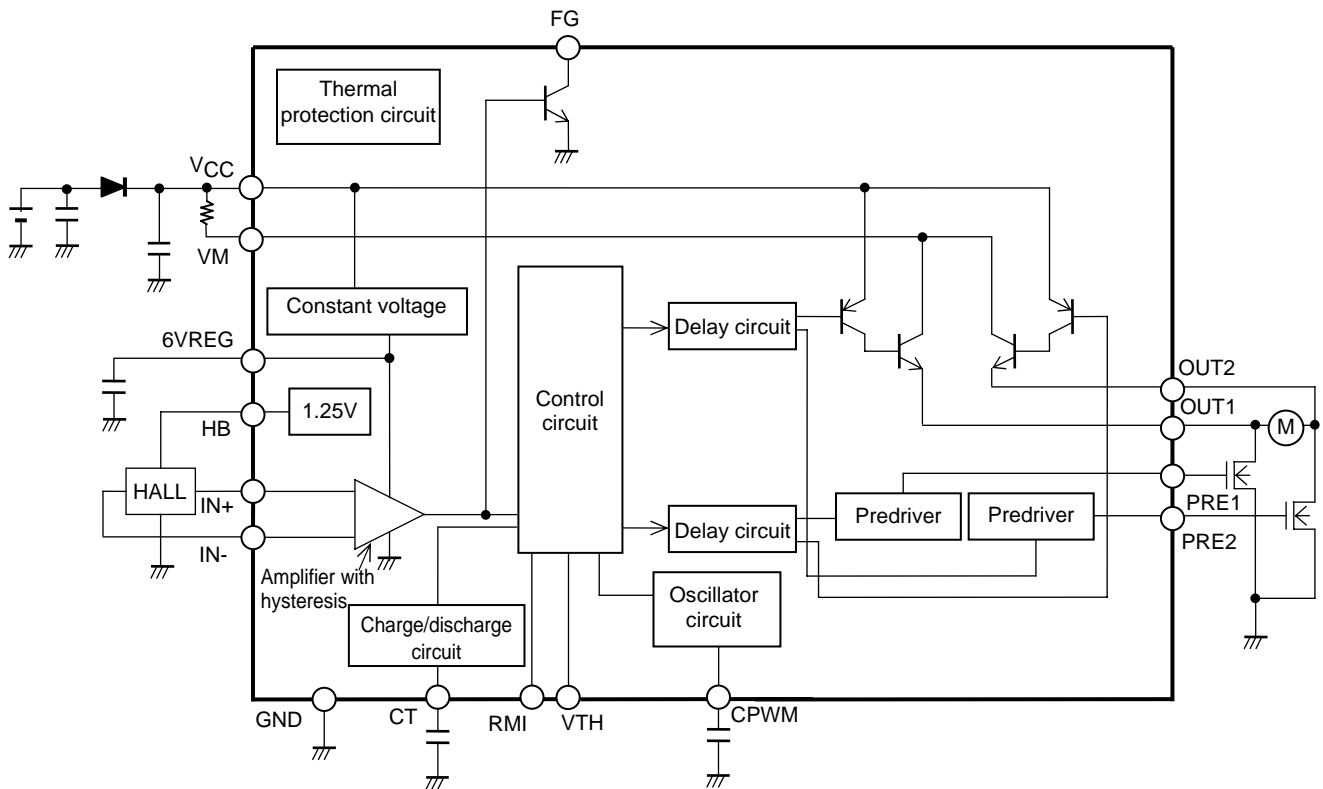

- SANYO Semiconductor Co.,Ltd. assumes no responsibility for equipment failures that result from using products at values that exceed, even momentarily, rated values (such as maximum ratings, operating condition ranges, or other parameters) listed in products specifications of any and all SANYO Semiconductor Co.,Ltd. products described or contained herein.
- SANYO Semiconductor Co.,Ltd. strives to supply high-quality high-reliability products, however, any and all semiconductor products fail or malfunction with some probability. It is possible that these probabilistic failures or malfunction could give rise to accidents or events that could endanger human lives, trouble that could give rise to smoke or fire, or accidents that could cause damage to other property. When designing equipment, adopt safety measures so that these kinds of accidents or events cannot occur. Such measures include but are not limited to protective circuits and error prevention circuits for safe design, redundant design, and structural design.
- In the event that any or all SANYO Semiconductor Co.,Ltd. products described or contained herein are controlled under any of applicable local export control laws and regulations, such products may require the export license from the authorities concerned in accordance with the above law.
- No part of this publication may be reproduced or transmitted in any form or by any means, electronic or mechanical, including photocopying and recording, or any information storage or retrieval system, or otherwise, without the prior written consent of SANYO Semiconductor Co.,Ltd.
- Any and all information described or contained herein are subject to change without notice due to product/technology improvement, etc. When designing equipment, refer to the "Delivery Specification" for the SANYO Semiconductor Co.,Ltd. product that you intend to use.
- Information (including circuit diagrams and circuit parameters) herein is for example only; it is not guaranteed for volume production.
- Upon using the technical information or products described herein, neither warranty nor license shall be granted with regard to intellectual property rights or any other rights of SANYO Semiconductor Co.,Ltd. or any third party. SANYO Semiconductor Co.,Ltd. shall not be liable for any claim or suits with regard to a third party's intellectual property rights which has resulted from the use of the technical information and products mentioned above.

This catalog provides information as of April, 2007. Specifications and information herein are subject to change without notice.