



SANYO Semiconductors DATA SHEET

LB11660RV — Monolithic Digital IC Single-Phase Full-Wave Driver For Fan Motor

Overview

The LB11660RV is a single-phase bipolar half pre-driver that can achieve high-efficient direct PWM drive with ease. It is ideal for driving small-sized cooling fans used in servers. The LB11660RV is provided with the RD (lock detection) output pin and the LB11660FV the FG (rotational speed detection) output pin, respectively.

Features

- Single-phase full-wave drive (15V-1.5A output transistor built in) upper output Tr incorporated half pre-driver.
- Variable speed control by an external signal.
→Separately-excited upper TR direct PWM control method, enabling silent, low-vibration variable speed control.
- Lowest speed setting possible.
- Current limiter circuit (the circuit actuated at $I_O = 1A$ when $R_f = 0.5\Omega$, R_f determines the limiter value.).
- Kickback absorption circuit built in.
- Soft switching circuit achieves low power consumption, low loss, and low noise driving at a time of phase change.
- HB built in.
- Lock protection and automatic reset functions incorporated (including a circuit that changes the ON/OFF ratio according to the power supply voltage).
- RD (lock detection) output.
- Thermal protection circuit incorporated (design guaranteed).

■ Any and all SANYO Semiconductor products described or contained herein do not have specifications that can handle applications that require extremely high levels of reliability, such as life-support systems, aircraft's control systems, or other applications whose failure can be reasonably expected to result in serious physical and/or material damage. Consult with your SANYO Semiconductor representative nearest you before using any SANYO Semiconductor products described or contained herein in such applications.

■ SANYO Semiconductor assumes no responsibility for equipment failures that result from using products at values that exceed, even momentarily, rated values (such as maximum ratings, operating condition ranges, or other parameters) listed in products specifications of any and all SANYO Semiconductor products described or contained herein.

SANYO Semiconductor Co., Ltd.

TOKYO OFFICE Tokyo Bldg., 1-10, 1 Chome, Ueno, Taito-ku, TOKYO, 110-8534 JAPAN

LB11660RV

Absolute Maximum Ratings at Ta = 25°C

| Parameter | Symbol | Conditions | Ratings | Unit |
|----------------------------------------------|-----------------------|---------------------------------|------------|------|
| V _{CC} maximum power supply voltage | V _{CC} max | | 20 | V |
| VM maximum power supply voltage | VM max | | 20 | V |
| OUT pin maximum output current | I _{OUT} max | R _f ≥0.39Ω | 1.5 | A |
| OUT pin output withstand voltage 1 | V _{OUT} max1 | | 20 | V |
| OUT pin output withstand voltage 2 | V _{OUT} max2 | T≤0.4μs | 26.5 | V |
| PRE pin maximum source current | IPSO max | | 30 | mA |
| PRE pin maximum sink current | IPSI max | | -7 | mA |
| PRE pin output withstand voltage | VP max | | 20 | V |
| HB maximum output current | HB | | 10 | mA |
| VTH input pin withstand voltage | VTH max | | 7 | V |
| RD output pin output withstand voltage | VRD max | | 18 | V |
| RD output current | IRD max | | 10 | mA |
| Allowable power dissipation | Pd max | Mounted on a specified board *1 | 0.8 | W |
| Operating temperature range | Topr | *2 | -30 to 95 | °C |
| Storage temperature range | Tstg | | -55 to 150 | °C |

*1 A circuit board for mounting (114.3mm×76.1mm×1.6mm, glass epoxy resin)

*2 T_j max = 150°C. Must be used within the operating temperature range in which T_j does not exceed 150°C.

Recommended Operating Range at Ta = 25°C

| Parameter | Symbol | Conditions | Ratings | Unit |
|---------------------------------------------|-----------------|------------|------------|------|
| V _{CC} power supply voltage | V _{CC} | | 4 to 15 | V |
| VM power supply voltage | V _{CC} | | 3 to 15 | V |
| Current limiter operating range | ILIM | | 0.6 to 1.2 | A |
| VTH input level voltage range | VTH | | 0 to 6 | V |
| Hall input common phase input voltage range | VICM | | 0.2 to 3 | V |

Electrical Characteristics at Ta = 25°C, V_{CC} = 12V, unless otherwise specified

| Parameter | Symbol | Conditions | Ratings | | | Unit |
|----------------------------------------------|-------------------|-------------------------------------------|---------|------|------|------|
| | | | min | typ | max | |
| Circuit current | I _{CC} 1 | During driving | | 9 | 12 | mA |
| HB voltage | VHB | IHB=5mA | 1.05 | 1.25 | 1.40 | V |
| 6VREG voltage | V6VREG | 6VREG=5mA | 5.80 | 6 | 6.20 | V |
| CT pin H level voltage | VCTH | | 3.4 | 3.6 | 3.8 | V |
| CT pin L level voltage | VCTL | | 1.4 | 1.6 | 1.8 | V |
| ICT pin charge current 1 | ICTC1 | V _{CC} =12V | 1.7 | 2.2 | 2.7 | μA |
| ICT pin charge current 2 | ICTC2 | V _{CC} =6V | 1.3 | 1.8 | 2.3 | μA |
| ICT pin discharge current 1 | ICTD1 | V _{CC} =12V | 0.11 | 0.15 | 0.19 | μA |
| ICT pin discharge current 2 | ICTD2 | V _{CC} =6V | 0.34 | 0.44 | 0.54 | μA |
| ICT charge/discharge ratio 1 | RCT1 | V _{CC} =12V | 12 | 15 | 18 | |
| ICT charge/discharge ratio 2 | RCT2 | V _{CC} =6V | 3 | 4 | 5 | |
| ICT charge/discharge ratio threshold voltage | VRCT | | 6 | 6.6 | 7.3 | V |
| VTH bias current | IBVTH | | -2 | -1 | 0 | μA |
| OUT output H saturation voltage | VOH | I _O =200mA, R _L =1Ω | | 0.6 | 0.8 | V |
| PRE output L saturation voltage | VPL | I _O =5mA | | 0.2 | 0.4 | V |
| PRE output H saturation voltage | VPH | I _O = -20mA | | 0.9 | 1.2 | V |

Continued on next page.

LB11660RV

Continued from preceding page.

| Parameter | Symbol | Conditions | Ratings | | | Unit |
|--------------------------------------------|--------|---------------------------------------------------|---------|-----|-----|------|
| | | | min | typ | max | |
| Current limiter | VRf | V _{CC} -VM | 450 | 500 | 550 | mV |
| PWM output H level voltage | VPWMH | | 2.2 | 2.5 | 2.8 | V |
| PWM output L level voltage | VPWML | | 0.4 | 0.5 | 0.7 | V |
| PWM external C capacitor charge current | IPWM1 | | -23 | -18 | -14 | μA |
| PWM external C capacitor discharge current | IPWM2 | | 18 | 24 | 30 | μA |
| PWM oscillation frequency | FPWM | C=200pF | 19 | 23 | 27 | kHz |
| Hall input sensitivity | VHN | Zero peak value (including offset and hysteresis) | | 15 | 25 | mV |
| RD output pin L voltage | VRD | IRD=5mA | | 0.2 | 0.3 | V |
| RD output pin leak current | IRDL | VRD=7V | | | 30 | μA |
| Thermal protection circuit | THD | Design target value *3 | 150 | 180 | 210 | °C |

*3 These are design guarantee values, and are not tested.

The thermal protection circuit is implemented to prevent the IC from being thermally damaged or burned when exposed to an environment exceeding the guaranteed operating temperature range. Thermal design must be carried out so that the thermal protection circuit will never be activated while the fan is running in a stable condition.

Package Dimensions

unit : mm (typ)

3178B

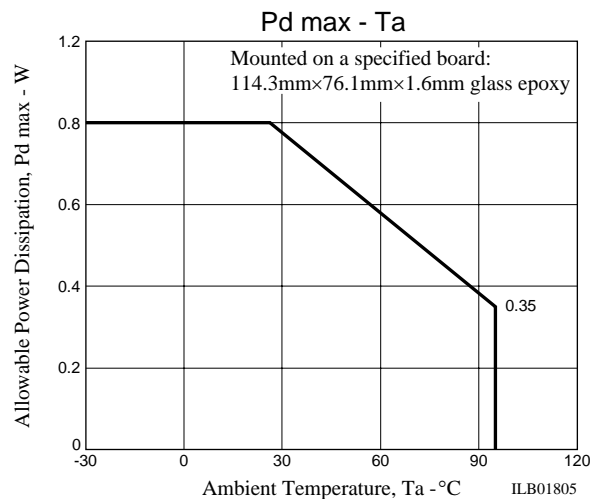
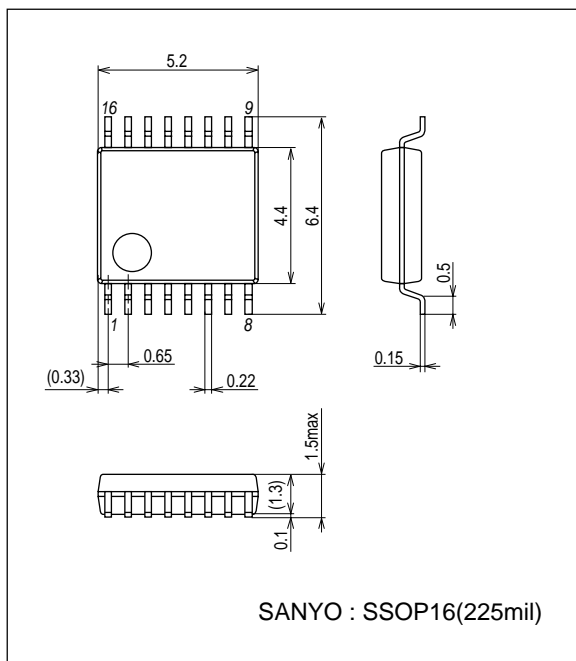

Truth Table

| IN- | IN+ | VTH | CPWM | CT | OUT1 | OUT2 | PRE1 | PRE2 | RD | Mode |
|-----|-----|-----|------|----|------|------|------|------|-----|-------------------------|
| H | L | L | H | L | H | OFF | L | H | L | Rotating - drive |
| L | H | | | | OFF | H | H | L | | |
| H | L | H | L | | OFF | OFF | L | H | | Rotating - regeneration |
| L | H | | | | OFF | OFF | H | L | | |
| H | L | - | - | H | OFF | OFF | L | H | OFF | Lock protection |
| L | H | | | | OFF | OFF | H | L | | |

CPWM-H: CPWM > VTH, CPWM-L: CPWM < VTH

LB11660RV

Pin Assignment

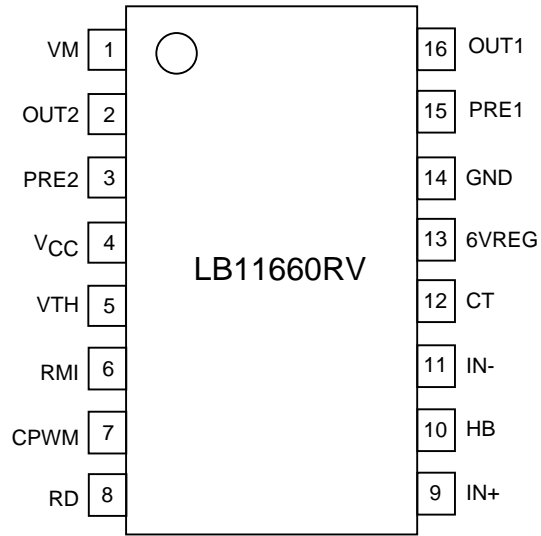

Top view

Sample Application Circuit 1

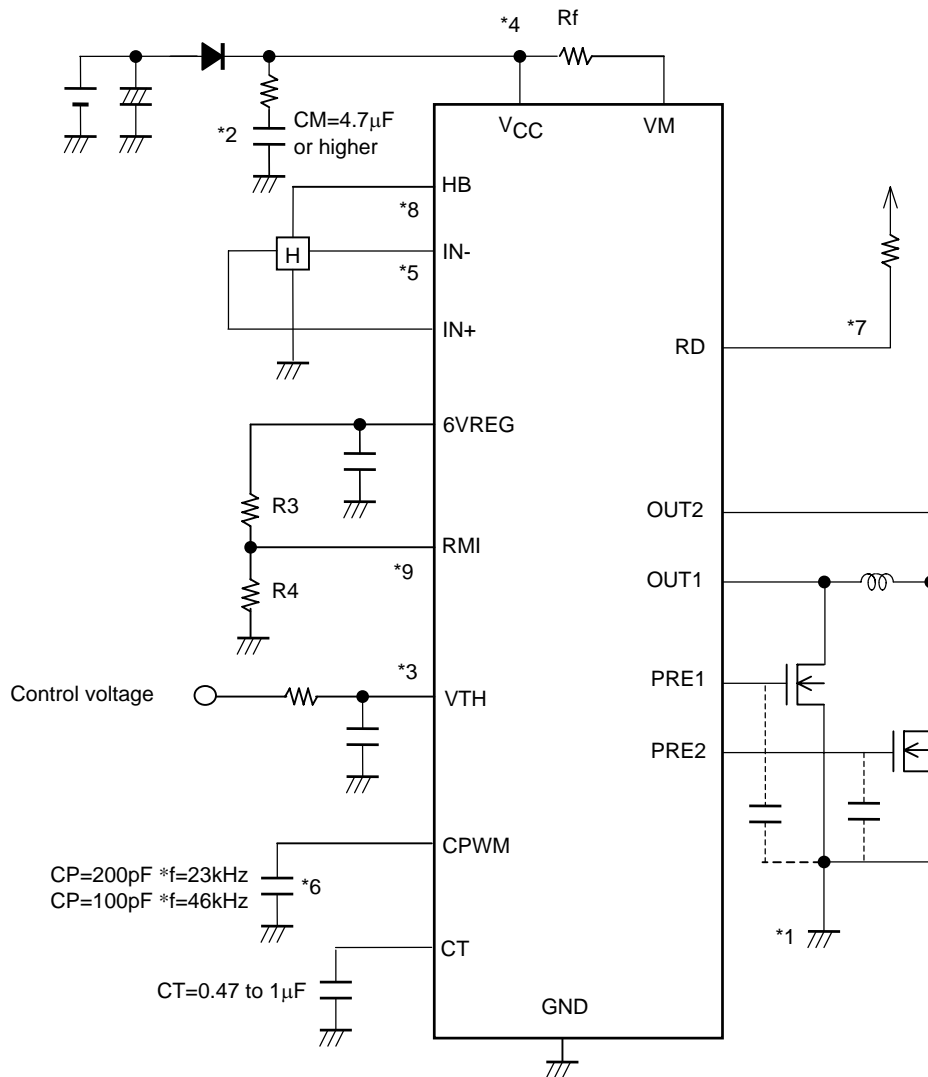

*1 <Power supply - GND wiring>

GRD of the IC is connected to the control circuit power supply system and GRD of the external N-channel is connected to the motor power supply system. Groundings must be installed separately and all external control components must be connected to the GND line of the IC.

*2 <Power stabilization capacitor for regeneration>

For the CM capacitor, that is a power stabilization capacitor for PWM drive and for absorption of kick-back, a capacitance of 4.7 μ F/25V or higher must be used. The CM capacitor must be connected without fail to prevent the IC from being damaged when power is tuned on or off.

*3 <Speed control>

1) Control voltage

The PWM duty ratio is determined by comparing the VTH pin voltage and the PWM oscillation waveforms.

When the VTH pin voltage drops, the 'ON' duty ratio increases, and when it drops to or below the PWM output L level voltage, the duty ratio is 100%.

2) Thermistor

In thermistor applications, the 6VREG voltage is usually divided by a resistor, and the voltage thus generated is supplied to the VTH pin.

The PWM duty ratio is varied by the changes in the VTH pin voltage which result from changes in temperature.

*4 < Setting the current limiter >

The current limiter is actuated when the voltage of the current-sensing resistors between V_{CC} and VM increases to 0.5V or more.

Since the current of a current limiter circuit is limited by the current determined by $I_O = VR_f/R_f$ (where $VR_f = 0.5V$ typ, R_f : current-sensing resistance), the current limiter is actuated at $I_O = 1A$ when $R_f = 0.5\Omega$. The R_f resistor must be connected without fail, and its constant must be within the recommended operating range for current limiters.

*5 <Hall input>

Wiring need to be short to prevent carrying of the noise. The Hall input circuit is a comparator having a hysteresis of 20mV. It is recommended that the Hall input level be more than three times (60mV_{p-p}) this hysteresis.

*6 < PWM oscillation frequency setting capacitor >

The oscillation frequency is 23kHz when $CP = 200pF$ and 46kHz when $CP = 100pF$, and this serves as the PWM fundamental frequency.

For the most part, the PWM frequency can be obtained from the following formula:

$$f [\text{kHz}] \approx (4.6 \times 10^6) \div C [\text{pF}]$$

*7 <RD output>

This is the open collector type output, which outputs "L" during rotation. It is set to 'OFF' when a lock is detected.

This output is left open when not in use.

*8 <HB pin>

This is a Hall element bias pin, that is, the 1.25V constant-voltage output pin.

*9 <RMI pin>

Lowest speed setting pin for speed control.

The minimum output duty setting is made with R3 and R4. The R4 is left open to stop operation at a duty ratio of 0%.

Rotation Speed Control Chart

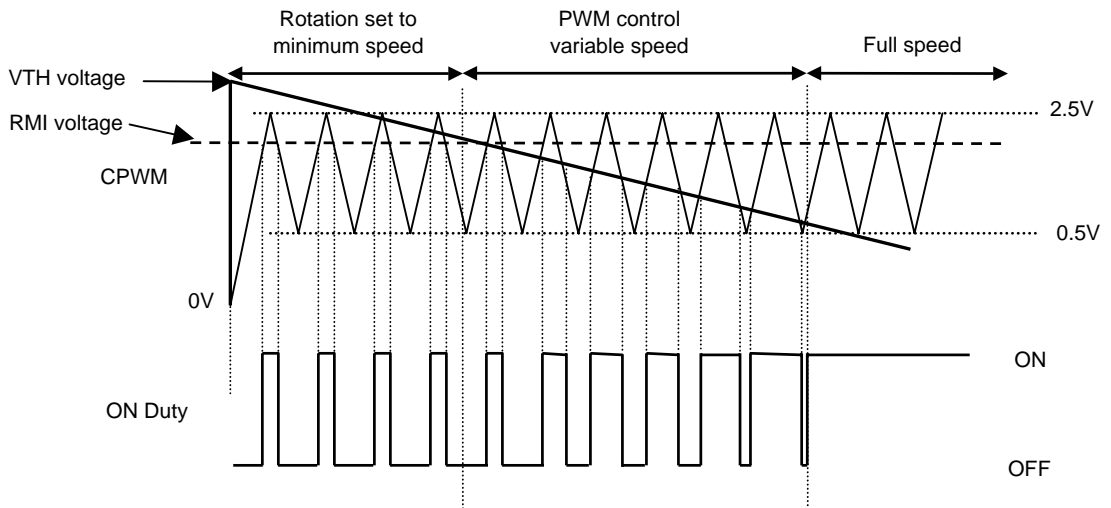
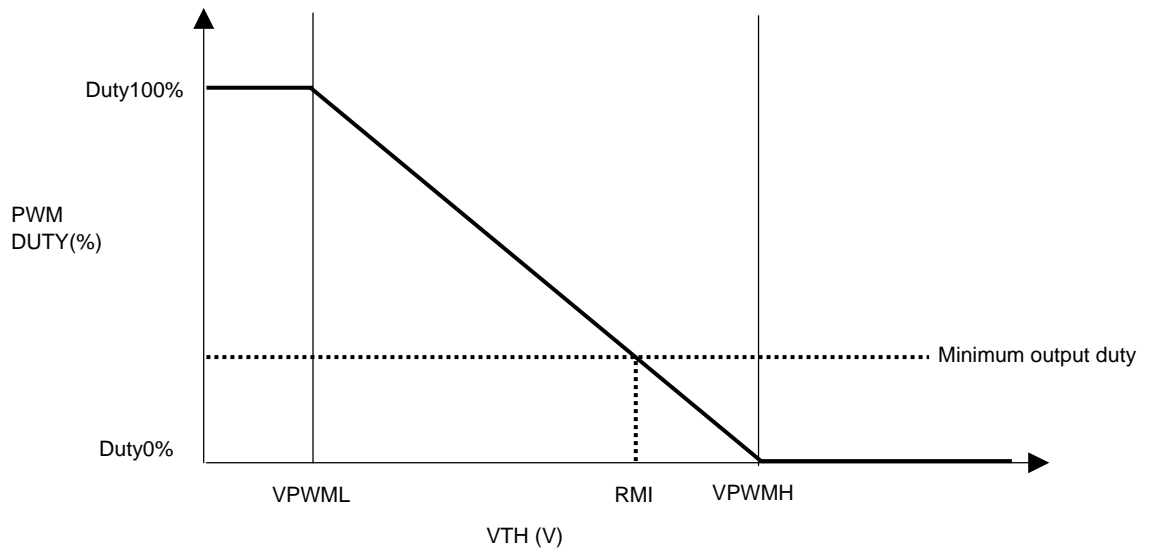

Internal Equivalent Circuit Diagram

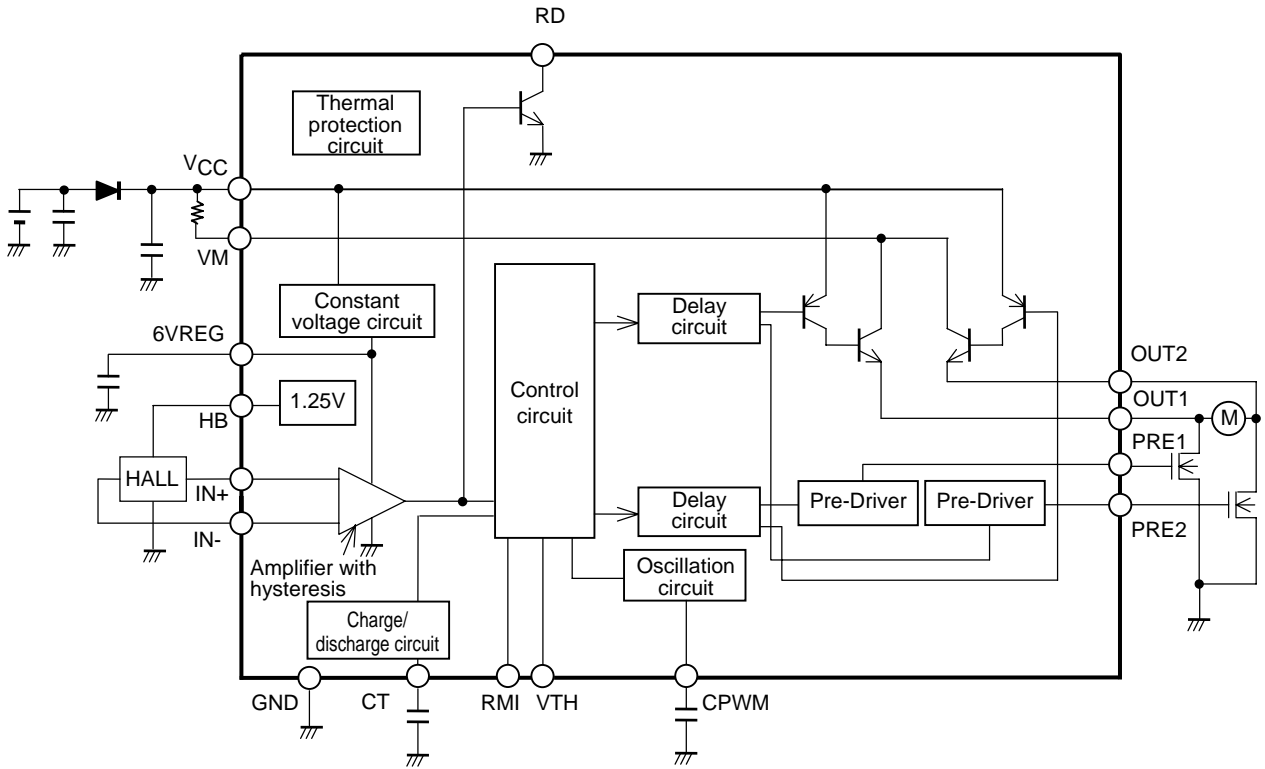

LB11660RV

Sample Application Circuit 2 <no minimum speed setting, thermistor input>

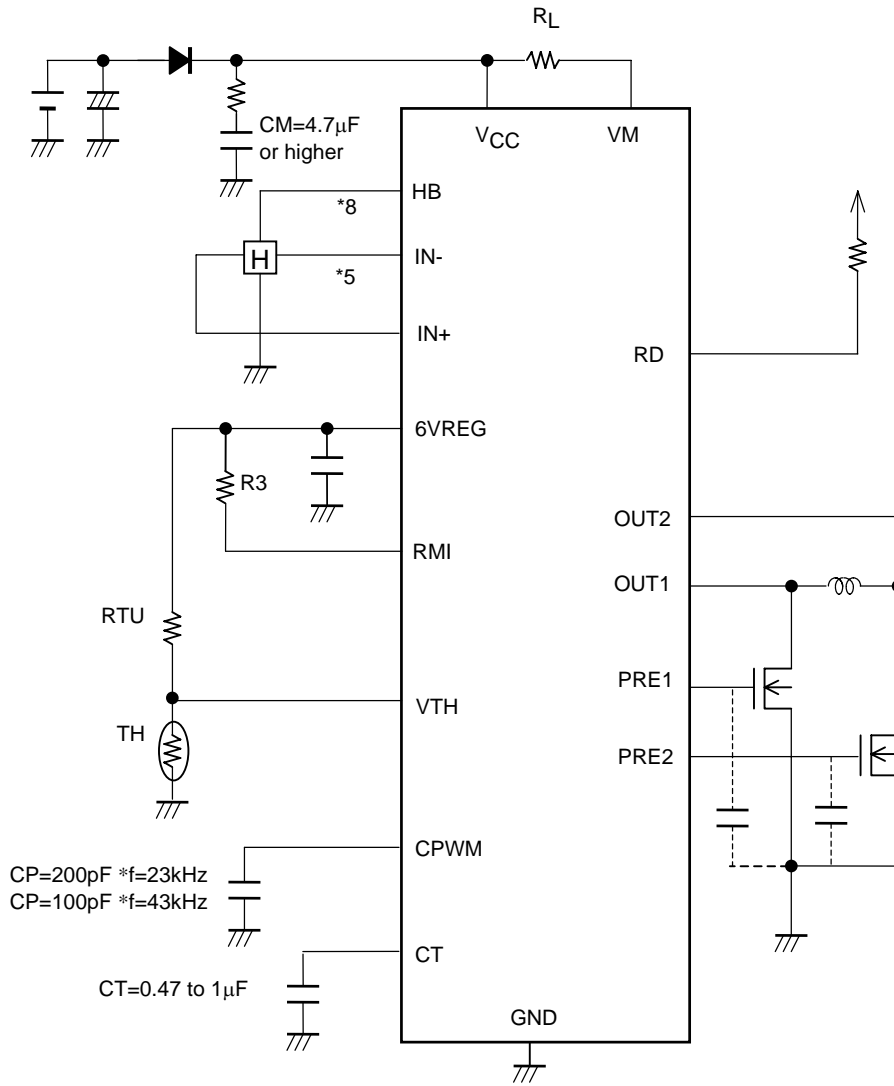

- Specifications of any and all SANYO Semiconductor products described or contained herein stipulate the performance, characteristics, and functions of the described products in the independent state, and are not guarantees of the performance, characteristics, and functions of the described products as mounted in the customer's products or equipment. To verify symptoms and states that cannot be evaluated in an independent device, the customer should always evaluate and test devices mounted in the customer's products or equipment.
- SANYO Semiconductor Co., Ltd. strives to supply high-quality high-reliability products. However, any and all semiconductor products fail with some probability. It is possible that these probabilistic failures could give rise to accidents or events that could endanger human lives, that could give rise to smoke or fire, or that could cause damage to other property. When designing equipment, adopt safety measures so that these kinds of accidents or events cannot occur. Such measures include but are not limited to protective circuits and error prevention circuits for safe design, redundant design, and structural design.
- In the event that any or all SANYO Semiconductor products (including technical data, services) described or contained herein are controlled under any of applicable local export control laws and regulations, such products must not be exported without obtaining the export license from the authorities concerned in accordance with the above law.
- No part of this publication may be reproduced or transmitted in any form or by any means, electronic or mechanical, including photocopying and recording, or any information storage or retrieval system, or otherwise, without the prior written permission of SANYO Semiconductor Co., Ltd.
- Any and all information described or contained herein are subject to change without notice due to product/technology improvement, etc. When designing equipment, refer to the "Delivery Specification" for the SANYO Semiconductor product that you intend to use.
- Information (including circuit diagrams and circuit parameters) herein is for example only; it is not guaranteed for volume production. SANYO Semiconductor believes information herein is accurate and reliable, but no guarantees are made or implied regarding its use or any infringements of intellectual property rights or other rights of third parties.

This catalog provides information as of December, 2006. Specifications and information herein are subject to change without notice.