



SANYO Semiconductors

DATA SHEET

LB11851M — Monolithic Digital IC Microprocessor Fan Motor Interface Driver

Overview

The LB11851M provides an interface between a microcontroller motor control signal and external MOS transistors. This device can implement a microprocessor fan driver with a minimal number of external components. The LB11851M is optimal for server and personal computer microprocessor fan drive in response to temperature or other external signals when high precision and high air flow are required.

Features

- Fan motor interface driver function (FGIN)
 - ⇒ This IC accepts a signal from a microcontroller and interfaces to external power transistors (PMOS and NMOS) to provide high-efficiency low-power single-phase full-wave drive.
- Variable speed input pin (PWMIN)
 - ⇒ PMOS side PWM control
 - NMOS side current regeneration using slow decay is used to achieve quite high-speed control.
- Built-in kickback absorption circuit (OUT1P/2P)
 - ⇒ This circuit absorbs the kickback current that is generated at phase switching or power on/off to achieve smooth current regeneration and protect the external transistors against destruction or degradation.
- Built-in current limiter circuit (SENSE)
 - ⇒ This circuit implements a chopper-type current limiting control that operates at startup and during lock protection mode.
 - The current detection voltage is set to a fixed 0.2V internally.
- Built-in microcontroller power supply (5VREG)

■ Any and all SANYO Semiconductor Co.,Ltd. products described or contained herein are, with regard to "standard application", intended for the use as general electronics equipment (home appliances, AV equipment, communication device, office equipment, industrial equipment etc.). The products mentioned herein shall not be intended for use for any "special application" (medical equipment whose purpose is to sustain life, aerospace instrument, nuclear control device, burning appliances, transportation machine, traffic signal system, safety equipment etc.) that shall require extremely high level of reliability and can directly threaten human lives in case of failure or malfunction of the product or may cause harm to human bodies, nor shall they grant any guarantee thereof. If you should intend to use our products for applications outside the standard applications of our customer who is considering such use and/or outside the scope of our intended standard applications, please consult with us prior to the intended use. If there is no consultation or inquiry before the intended use, our customer shall be solely responsible for the use.

■ Specifications of any and all SANYO Semiconductor Co.,Ltd. products described or contained herein stipulate the performance, characteristics, and functions of the described products in the independent state, and are not guarantees of the performance, characteristics, and functions of the described products as mounted in the customer's products or equipment. To verify symptoms and states that cannot be evaluated in an independent device, the customer should always evaluate and test devices mounted in the customer's products or equipment.

SANYO Semiconductor Co., Ltd.

TOKYO OFFICE Tokyo Bldg., 1-10, 1 Chome, Ueno, Taito-ku, TOKYO, 110-8534 JAPAN

LB11851M

Specifications

Allowable Operating Ranges at $T_a = 25^\circ\text{C}$

Parameter	Symbol	Conditions	Ratings	Unit
Maximum supply voltage	V_{CC} max		18	V
OUTN pin maximum output current	IOUTN max		20	mA
OUTP pin maximum output current	IOUTP max		20	mA
OUT pin voltage handling capacity	VOUT max		18	V
5VREG maximum output current	I5VREG max		20	mA
Allowable power dissipation	Pd max	When mounted on the specified circuit board *1	0.8	W
		Independent IC	0.3	W
Operating temperature	Topr	*2	-30 to +95	$^\circ\text{C}$
Storage temperature	Tstg		-55 to +150	$^\circ\text{C}$

*1 Specified substrate : 114.3mm x 76.1mm x 1.6mm, glass epoxy board.

*2 Do not exceed T_J max = 150°C

Recommended Operating Ranges at $T_a = 25^\circ\text{C}$

Parameter	Symbol	Conditions	Ratings	Unit
Supply voltage - V_{CC}	V_{CC}		6 to 16	V
PWM high-level input voltage range	VPWMINH		2.1 to 5	V
PWM low-level input voltage range	VPWMINL		0 to 0.4	V
FGIN high-level input voltage range	VFGINH		2.1 to 5	V
FGIN low-level input voltage range	VFGINL		0 to 0.3	V
SENSE input voltage range	VSENop		0 to 5	V

Electrical Characteristics at $T_a = 25^\circ\text{C}$, $V_{DD} = 12\text{V}$

Parameter	Symbol	Conditions	Ratings			Unit
			min	typ	max	
Circuit current	I_{CC1}	With no load	3.5	5	6.5	mA
5VREG voltage	5VREG	5VREG = 10mA	4.8	5	5.2	V
SENSE pin detection voltage	VSENth		0.15	0.19	0.23	V
FGIN high-level input current	FGIhi	$V_{IN} = 3\text{V}$	60	80	100	μA
FGIN low-level input current	FGIlow	$V_{IN} = 0\text{V}$	-27	-21	-15	μA
PWMIN high-level current	PWMIhi	$V_{IN} = 3\text{V}$	35	45	55	μA
PWMIN low-level current	PWMIlow	$V_{IN} = 0\text{V}$	-27	-21	-14	μA
OUT1P, OUT2P high-level output voltage	V_{O12PH}	$I_O = 10\text{mA}$ *2	10	11	11.9	V
OUT1P, OUT2P low-level output voltage	V_{O12PL}	$I_O = 10\text{mA}$ *2	3	4	5	V
OUT1N, OUT2N high-level output voltage	V_{O12NH}	$I_O = 10\text{mA}$ *1	9	10	11.9	V
OUT1N, OUT2N low-level output voltage	V_{O12NL}	$I_O = 10\text{mA}$ *1	0.1	1	2	V

*1 : There is a built-in 100Ω gate protection resistor.

*2 : There is a built-in 300Ω gate protection resistor.

LB11851M

Truth Table

FGIN	PWMIN	SENSE	OUT1P	OUT1N	OUT2P	OUT2N	Mode
L	L	L	L	L	H	H	OUT1 → 2 drive
H			H	H	L	L	OUT2 → 1 drive
L	H	L	H	L	H	H	Regeneration mode (low side regeneration)
H			H	H	L		
L	L	H	H	L	H	H	Current limiter (low side regeneration)
H			H	H	L		

Note 1 : For the SENSE pin, the "H" state is 0.2V or higher.

Note 2 : The IC goes to regeneration mode (no motor drive applied) when the microcontroller is reset (the output high-impedance state).

Package Dimensions

unit : mm (typ)

3086B

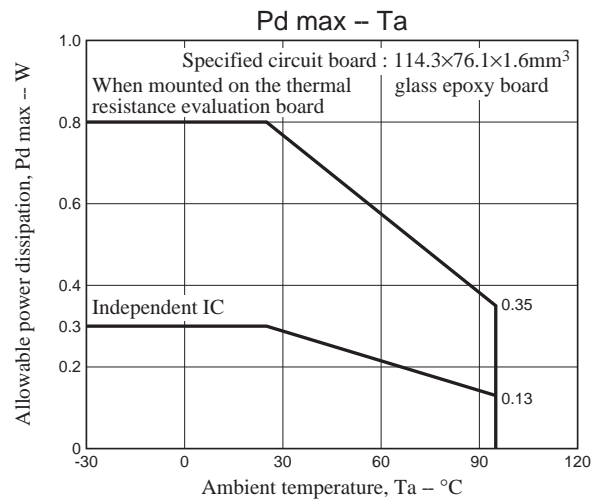
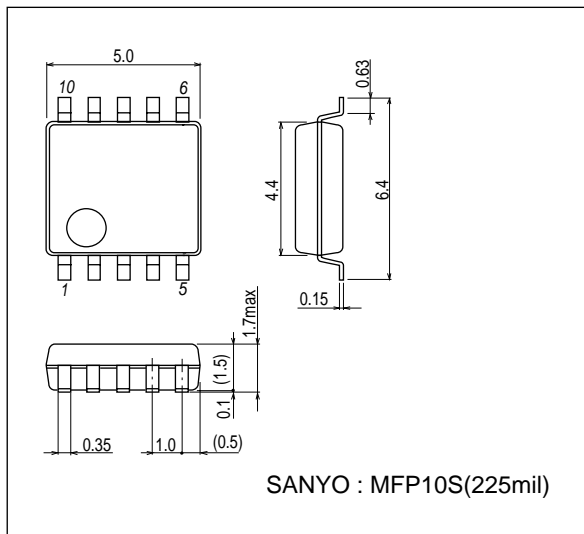

Pin Assignment

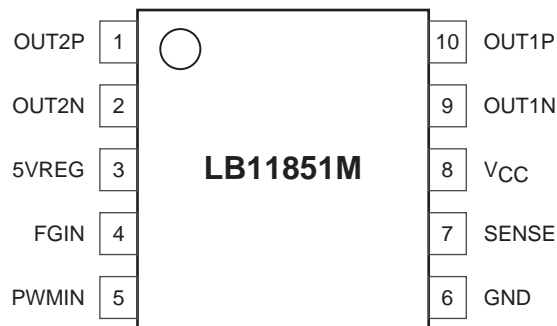

Top View

LB11851M

1. Power supply (V_{CC} and V_M) and ground

The wiring is separated into the control IC side (V_{CC} line) and the motor output side (V_M line) by the diode DI, which protects the IC from destruction on reverse connection. The application circuit uses $1\mu\text{F}$ capacitors to prevent line oscillation when kickback occurs. Similarly, $1\mu\text{F}$ capacitors are also used on the V_{CC} line for power supply line stabilization.

2. PWMIN

The LB11851M accepts an open-drain output signal from the microcontroller with this pin and controls the on/off states of the PMOS transistor (OUT1P and OUT2P) outputs accordingly. A constant-current bias is provided from 5VREG internally to the IC.

3. FGIN

The LB11851M accepts a CMOS output from the microcontroller with this pin and determines the drive phase output (OUT1P, OUT2P, OUT1N, or OUT2N).

4. 5VREG

This is the power supply for the microcontroller, Hall effect sensors, and other circuits. A capacitor with a value of $1\mu\text{F}$ is used for output stabilization. This pin has an output current capacity of 20mA.

5. SENSE

A sensing resistor is used for current detection. If the SENSE pin voltage exceeds 0.2V, the PMOS transistors are turned off and only low side regeneration is performed.

Block Diagram

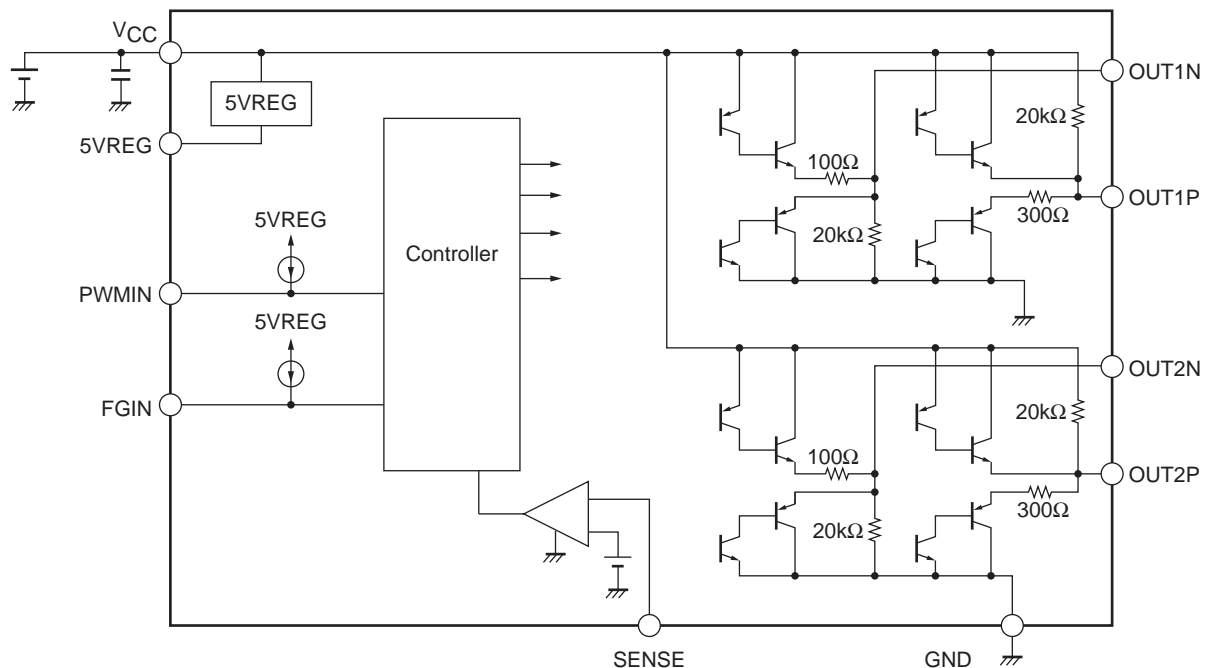

LB11851M

Application Circuit Example (12V)

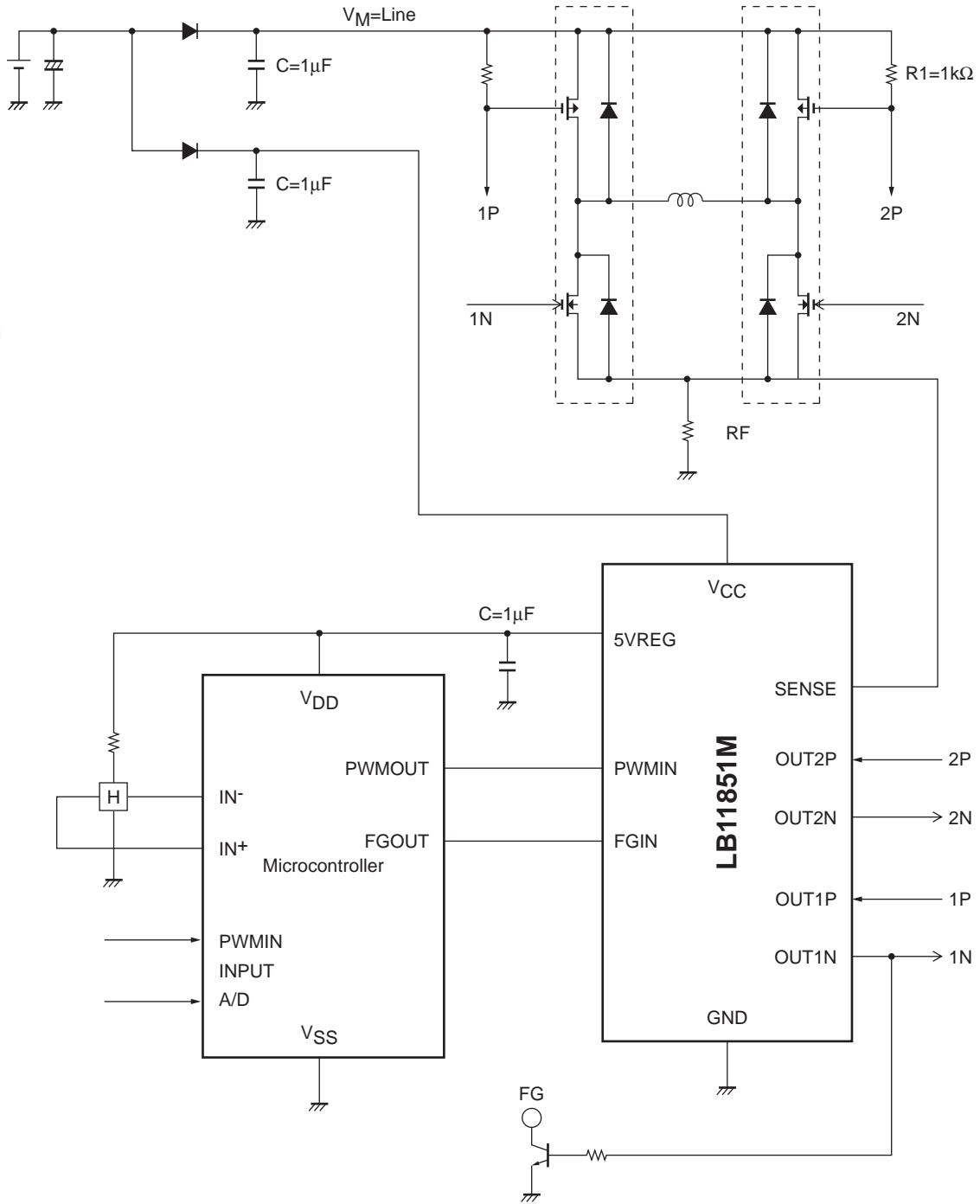

- SANYO Semiconductor Co.,Ltd. assumes no responsibility for equipment failures that result from using products at values that exceed, even momentarily, rated values (such as maximum ratings, operating condition ranges, or other parameters) listed in products specifications of any and all SANYO Semiconductor Co.,Ltd. products described or contained herein.
- SANYO Semiconductor Co.,Ltd. strives to supply high-quality high-reliability products, however, any and all semiconductor products fail or malfunction with some probability. It is possible that these probabilistic failures or malfunction could give rise to accidents or events that could endanger human lives, trouble that could give rise to smoke or fire, or accidents that could cause damage to other property. When designing equipment, adopt safety measures so that these kinds of accidents or events cannot occur. Such measures include but are not limited to protective circuits and error prevention circuits for safe design, redundant design, and structural design.
- In the event that any or all SANYO Semiconductor Co.,Ltd. products described or contained herein are controlled under any of applicable local export control laws and regulations, such products may require the export license from the authorities concerned in accordance with the above law.
- No part of this publication may be reproduced or transmitted in any form or by any means, electronic or mechanical, including photocopying and recording, or any information storage or retrieval system, or otherwise, without the prior written consent of SANYO Semiconductor Co.,Ltd.
- Any and all information described or contained herein are subject to change without notice due to product/technology improvement, etc. When designing equipment, refer to the "Delivery Specification" for the SANYO Semiconductor Co.,Ltd. product that you intend to use.
- Information (including circuit diagrams and circuit parameters) herein is for example only; it is not guaranteed for volume production.
- Upon using the technical information or products described herein, neither warranty nor license shall be granted with regard to intellectual property rights or any other rights of SANYO Semiconductor Co.,Ltd. or any third party. SANYO Semiconductor Co.,Ltd. shall not be liable for any claim or suits with regard to a third party's intellectual property rights which has resulted from the use of the technical information and products mentioned above.

This catalog provides information as of April, 2007. Specifications and information herein are subject to change without notice.