



SANYO Semiconductors

DATA SHEET

LB11889M

Monolithic Digital IC
— For VCR Capstan
Three-Phase Brushless Motor Driver

Overview

The LB11889M is three-phase brushless motor driver for VCR capstan motors.

Features

- 3-phase full-wave current linear drive.
- Torque ripple correction circuit (fixed correction ratio).
- Current limiter circuit with control characteristics gain switching.
- Output stage upper/lower oversaturation prevention circuit (No external capacitor required).
- FG amplifier built in.
- Thermal shutdown circuit built in.

Absolute Maximum Ratings at Ta = 25°C

Parameter	Symbol	Conditions	Ratings	Unit
Maximum power supply voltage	V _{CC} max		7	V
	V _S max		24	V
Maximum output current	I _O max		1.3	A
Allowable power dissipation voltage	Pd max	Independent IC	950	mW
Operating temperature	T _{opr}		-20 to +75	°C
Storage temperature	T _{stg}		-55 to +150	°C

Allowable Operating Range at Ta = 25°C

Parameter	Symbol	Conditions	Ratings	Unit
Power supply voltage	V _S		5 to 22	V
	V _{CC}		4.5 to 5.5	V
Hall input amplitude	V _{HALL}	Between hall inputs	±30 to ±80	mV _{o-p}
GSENSE input range	V _{GSENSE}	Relative to the control system GND	-0.20 to +0.20	V

■ Any and all SANYO Semiconductor products described or contained herein do not have specifications that can handle applications that require extremely high levels of reliability, such as life-support systems, aircraft's control systems, or other applications whose failure can be reasonably expected to result in serious physical and/or material damage. Consult with your SANYO Semiconductor representative nearest you before using any SANYO Semiconductor products described or contained herein in such applications.

■ SANYO Semiconductor assumes no responsibility for equipment failures that result from using products at values that exceed, even momentarily, rated values (such as maximum ratings, operating condition ranges, or other parameters) listed in products specifications of any and all SANYO Semiconductor products described or contained herein.

SANYO Semiconductor Co., Ltd.

TOKYO OFFICE Tokyo Bldg., 1-10, 1 Chome, Ueno, Taito-ku, TOKYO, 110-8534 JAPAN

LB11889M

Electrical Characteristics at Ta = 25°C, VCC = 5V, VS = 15V

Parameter	Symbol	Conditions	Ratings			Unit
			min	typ	max	
VCC power supply current	ICC	RL = ∞, VCTL = 0V, VLIM = 0V (at static mode)		12	18	mA
Output						
Output saturation voltage	VOsat1	IO = 500mA, Rf = 0.5Ω, sink+source VCTL = VLIM = 5V (With saturation prevention)		2.1	2.6	V
	VOsat2	IO = 1.0A, Rf = 0.5Ω, sink+source VCTL = VLIM = 5V (With saturation prevention)		2.6	3.5	
Output leak current	IOleak				1.0	mA
FR						
FR pin input threshold voltage	VFSR		2.25	2.50	2.75	V
FR pin input input bias current	Ib (FSR)		-5.0			μA
Control						
CTLREF pin voltage	VCREF		2.37	2.50	2.63	V
CTLREF pin input range	VCREF IN		1.70		3.50	V
CTL pin input bias current	Ib (CTL)	VCTL = 5V, CTLREF : OPEN			8.0	μA
CTL pin control start voltage	VCTL (ST)	Rf = 0.5Ω, VLIM = 5V, IO ≥ 10mA With hall input logic fixed (U, V, W = H, H, L)	2.20	2.35	2.50	V
CTL pin control switching voltage	VCTL (ST2)	Rf = 0.5Ω, VLIM = 5V	3.00	3.15	3.30	V
CTL pin control Gm1	Gm1 (CTL)	Rf = 0.5Ω, ΔIO = 200mA With hall input logic fixed (U, V, W = H, H, L)	0.52	0.65	0.78	A/V
CTL pin control Gm2	Gm2 (CTL)	Rf = 0.5Ω, ΔVCTL = 200mV With hall input logic fixed (U, V, W = H, H, L)	1.20	1.50	1.80	A/V
Current limiter						
LIM current limiter offset voltage	Voff (LIM)	Rf = 0.5Ω, VCTL = 5V, IO ≥ 10mA With hall input logic fixed (U, V, W = H, H, L)	140	200	260	mV
LIM pin input bias current	Ib (LIM)	VCTL = 5V, CTLREF : OPEN, VLIM = 0V	-2.5			μA
LIM pin current limiter level	Ilim	Rf = 0.5Ω, VCTL = 5V, VLIM = 2.06V With hall input logic fixed (U, V, W = H, H, L)	830	900	970	mA
Hall amplifier						
Hall amplifier input offset voltage	Voff (HALL)		-6		+6	mV
Hall amplifier input bias current	Ib (HALL)			1.0	3.0	μA
Hall amplifier common-mode	VCM (HALL)		1.3		3.3	V
TRC						
Torque ripple correction factor	TRC	At bottom and peak of Rf waveform at IO = 200mA (RF = 0.5Ω, ADJ-OPEN) Note 2		9		%
ADJ pin voltage	VADJ		2.37	2.50	2.63	V
FG amplifier						
FG amplifier input offset voltage	Voff (FG)		-8		+8	mV
FG amplifier input bias current	Ib (FG)		-100			nA
FG amplifier output saturation voltage	VOsat (FG)	At internal pull-up resistor on the sink side			0.5	V
FG amplifier common-mode input voltage	VCM (FG)		0.5		4.0	V
Saturation						
Saturation prevention circuit lower set voltage	VOsat (DET)	Voltage between each OUT and Rf at IO = 10mA, Rf = 0.5Ω, VCTL = VLIM = 5V	0.175	0.25	0.325	V
TSD						
TSD operating temperature	T-TSD	(Design target) Note.1		180		°C
TSD temperature hysteresis width	ΔTSD	(Design target) Note.1		20		°C

Note 1. No measurements are made on the parameters with Note (Design target).

LB11889M

Note 2. The torque ripple correction factor is obtained based on the voltage waveform across Rf as shown below.

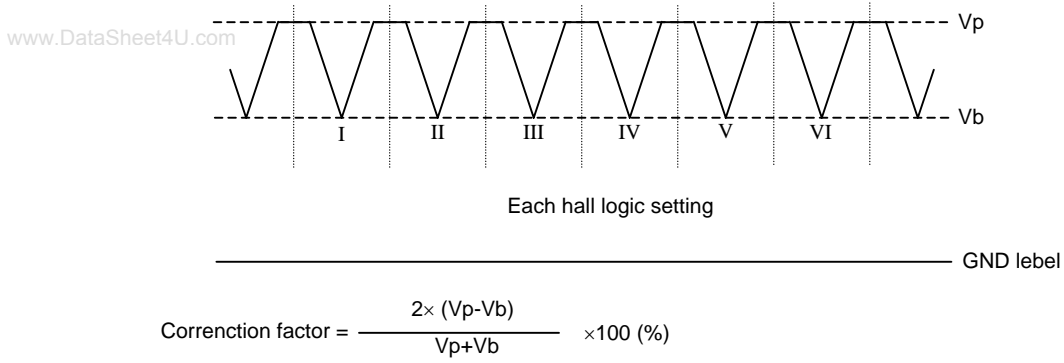

Package Dimensions

unit : mm (typ)

3280A

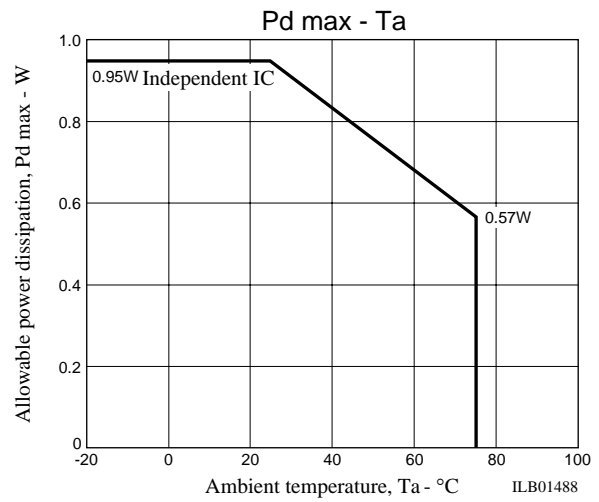
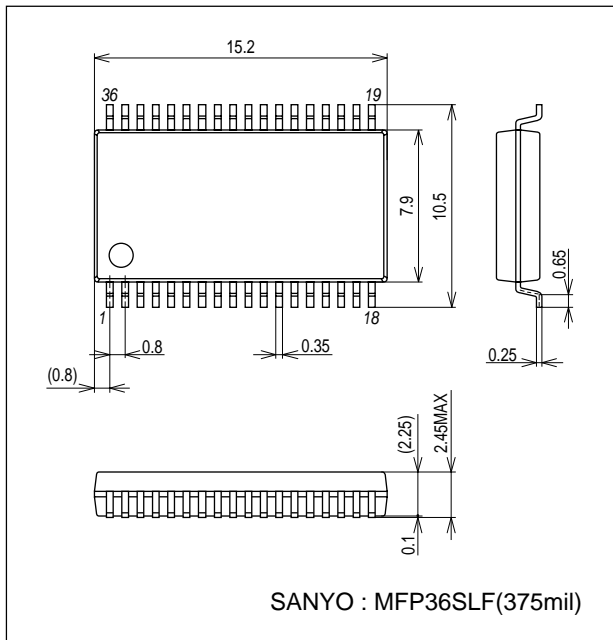

Truth Table and Control Function

	Source → Sink	Hall input			FR
		U	V	W	
1	V → W	H	H	L	H
	W → V				L
2	U → W	H	L	L	H
	W → U				L
3	U → V	H	L	H	H
	V → U				L
4	W → V	L	L	H	H
	V → W				L
5	W → U	L	H	H	H
	U → W				L
6	V → U	L	H	L	H
	U → V				L

Note) "H" for FR represents a voltage of 2.75V or greater ; "L" represents a voltage of 2.25V or lower (at V_{CC} = 5V).
 Note) Input "H" for all input represents that (+) is higher than each phase input (-) by 0.01V or greater ; input "L" represents that (+) is lower than each phase input (-) by 0.01V or greater.
 Note) Since this drive scheme is the 180° energizing scheme, phases other than Sink, Source phases are not turned OFF.

Control Function & Current Limiter Function

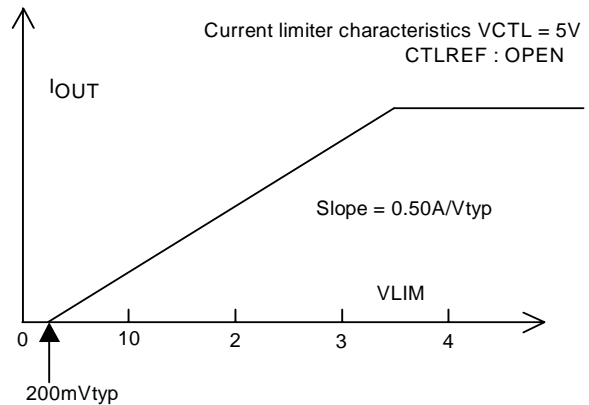
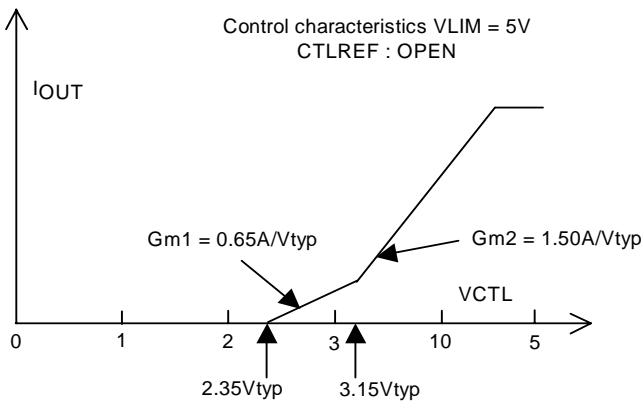

LB11889M

Pin Functions

Pin name	Pin no.	Functions
FGIN (-)	3	Input pin for the FG amplifier to be used with inverted input. A feedback resistor is connected between this pin and FG OUT.
FGIN (+)	4	Noninverting input pin for the FG amplifier to be used as differential input. No bias is applied internally.
FG-OUT	5	FG amplifier output pin with resistive load internally.
CTL	6	Speed control pin. Control is performed by means of constant current drive which is applied by current feedback from Rf. Gm = 0.65A/V & 1.50A/V TYP at Rf = 0.5Ω
CTLREF	7	Control reference voltage pin. The voltage is set at approximately V _{CC} /2 internally, but can be varied by applying a voltage through a low impedance. (The input impedance is approximately 2.5kΩ.)
LIM	8	Current limiter function control pin. This pin voltage is capable of varying the output current lineally. Slope = 0.5A/V TYP at Rf = 0.5Ω
FC	9	Speed control loop's frequency characteristics correction pin.
U _{IN+} , U _{IN-} V _{IN+} , V _{IN-} W _{IN+} , W _{IN-}	10, 11 12, 13 14, 15	U phase hall element input pin. "H" for logic represents IN+>IN-. V phase hall element input pin. "H" for logic represents IN+>IN-. W phase hall element input pin. "H" for logic represents IN+>IN-.
V _{CC}	16	Power supply pin used to supply to each circuit other than the output blocks inside the IC. This voltage must be stabilized to reject noise and ripple.
VS	21	Power supply pin for output blocks.
ADJ	22	Pin to be used to adjust the torque ripple correction factor externally. When adjusting the correction factor, apply voltage externally to the ADJ pin through a low impedance. Increasing the applied voltage decreases the correction factor ; lowering the applied voltage increases the correction factor. The rate of change, when left open, ranges approximately from 0 to 2 times. (Approximately V _{CC} /2 is set internally and the input impedance is approximately 5kΩ.)
Rf (PWR) Rf (SNS)	23 31	Output current detection pins. Current feedback is provided to the control blocks by connecting Rf between the pins and GND. The operation of the lower over-saturation prevention circuit and torque ripple correction circuit depends on the pin voltage. In particular, since the oversaturation prevention level is set by the pin voltage, decreasing the Rf value extremely may cause the lower over-saturation prevention to work less efficiently in the large current region. The PWR pin and SENSE pin must be connected.
U _{OUT} V _{OUT} W _{OUT}	26 27 28	U phase output pin V phase output pin W phase output pin } (With spark killer diode built in)
GSENSE	32	GND sensing pin. By connecting this pin to GND in the vicinity of the Rf resistor side of the Rf included motor GND wiring, the influence that the GND common impedance exerts on Rf can be excluded. (Must not be left open.)
FR	33	Forward/reverse select pin. This pin voltage determines forward/reverse. (V _{th} = 2.5V typ. At V _{CC} = 5V)
GND	34	GND for other than output transistors. The lowest potential of output transistors is on the Rf pin.

LB11889M

Each Input/Output Equivalent Circuit

Pin name	Input/Output equivalent circuit
<p>U_{IN} (+)</p> <p>U_{IN} (-)</p> <p>V_{IN} (+)</p> <p>V_{IN} (-)</p> <p>W_{IN} (+)</p> <p>W_{IN} (-)</p>	
<p>U_{OUT}</p> <p>V_{OUT}</p> <p>W_{OUT}</p> <p>V_S</p> <p>R_f (POWER)</p> <p>R_f (SENSE)</p>	
<p>CTL</p> <p>LIM</p> <p>CTLREF</p>	
<p>FR</p> <p>ADJ</p>	

Continued on next page.

LB11889M

Continued from preceding page.

Pin name	Input/output equivalent circuit
<p>FG_{IN} (-) FG_{IN} (+)</p>	
<p>FG_{OUT} FC</p>	

Block Diagram

www.DataSheet4U.com

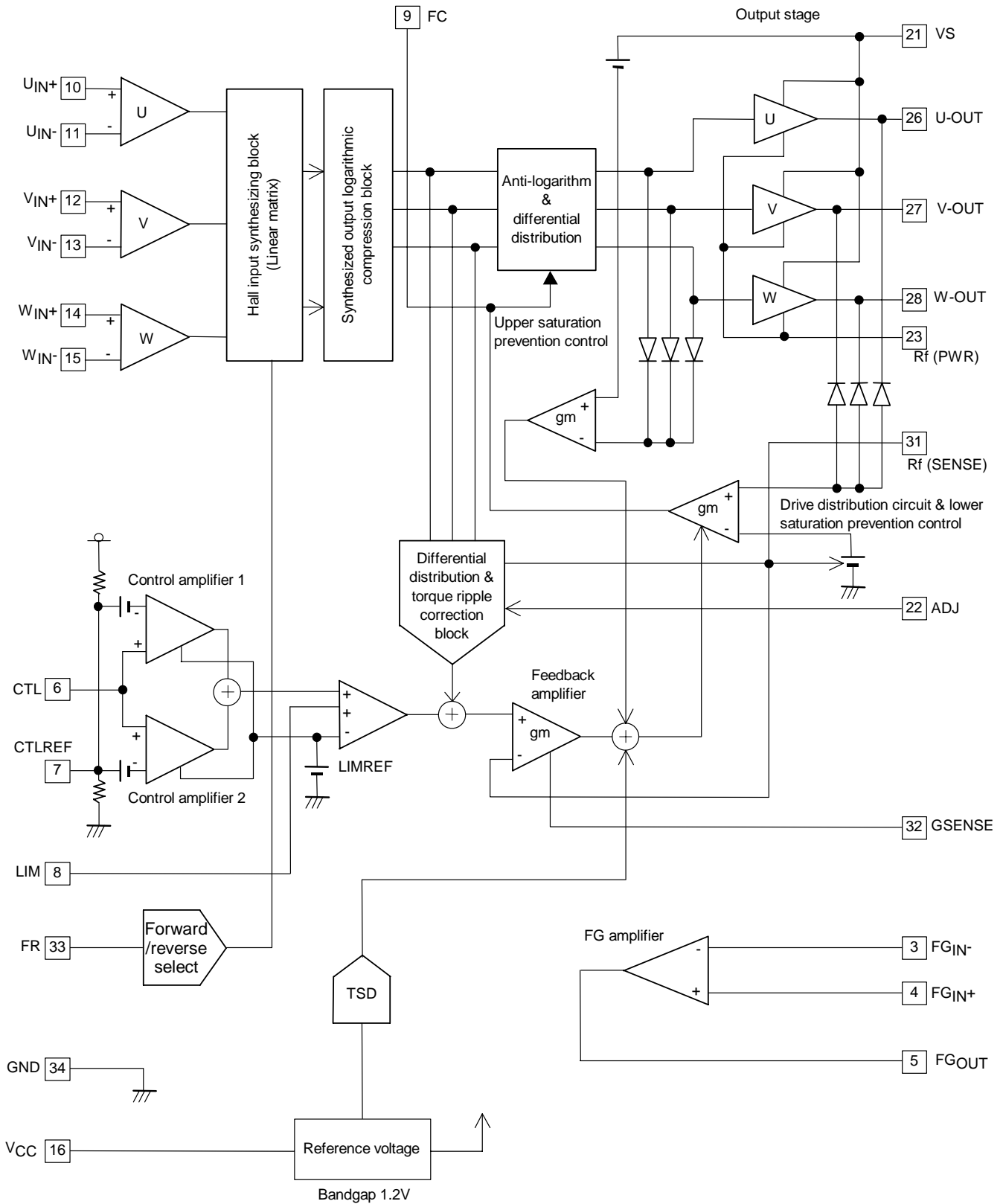

LB11889M

Pin Assignment

www.DataSheet4U.com

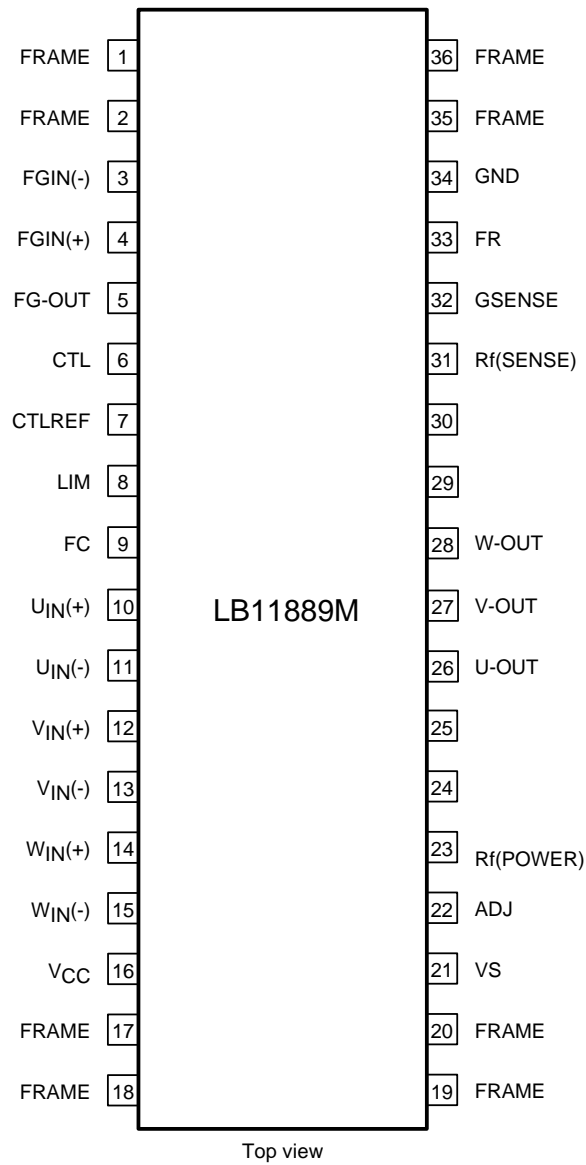

Note: Although the FRAME pins and the GND pin are not connected internally in the IC, the FRAME pins must be connected to the GND pin externally for ground potential stabilization.

LB1189M

Sample Application Circuit

www.DataSheet4U.com

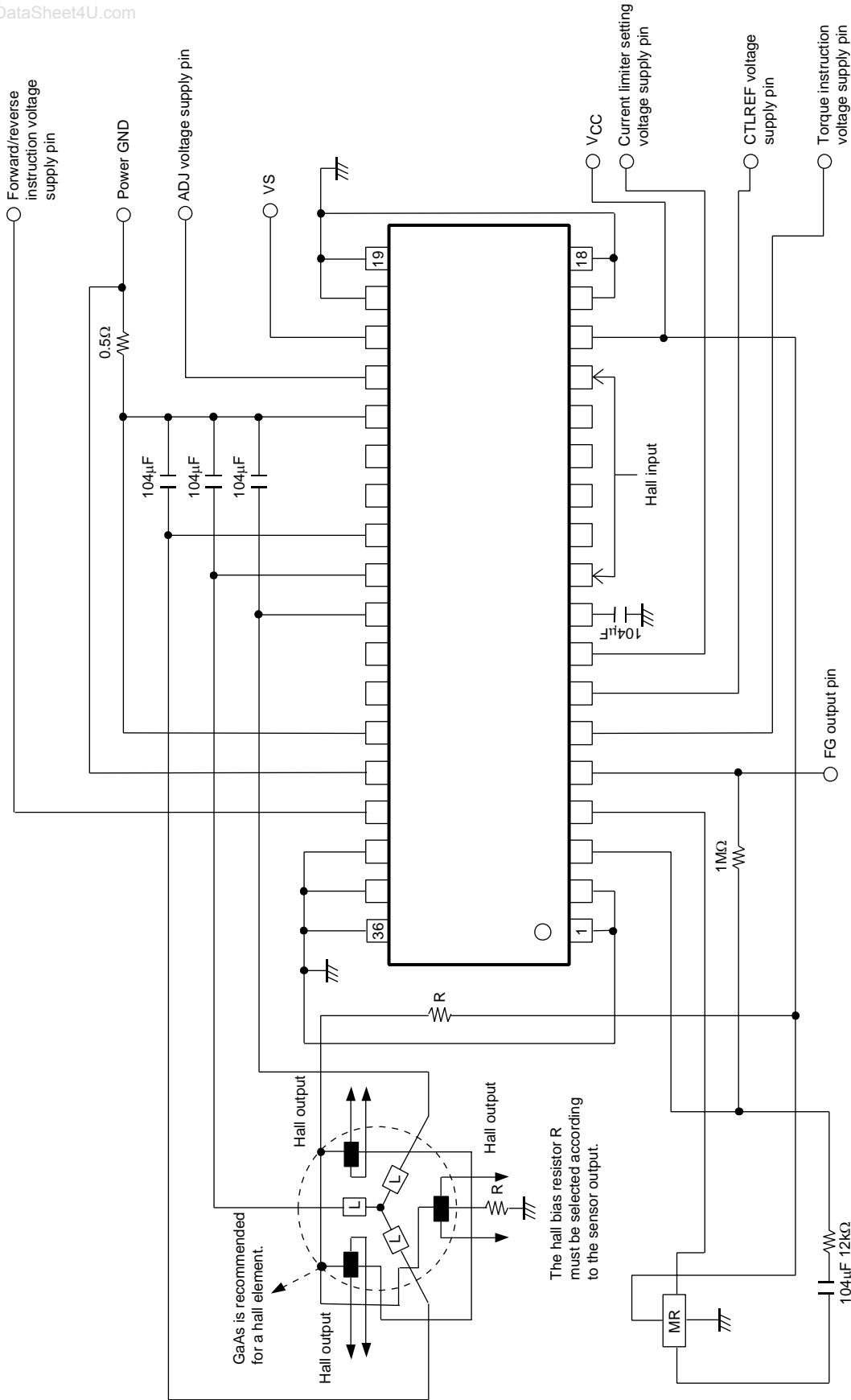

GaAs is recommended for a hall element.

The hall bias resistor R must be selected according to the sensor output.

Note) The component values shown in this application circuit example are merely provided as examples, and circuit operating characteristics are not guaranteed.

- Specifications of any and all SANYO Semiconductor products described or contained herein stipulate the performance, characteristics, and functions of the described products in the independent state, and are not guarantees of the performance, characteristics, and functions of the described products as mounted in the customer's products or equipment. To verify symptoms and states that cannot be evaluated in an independent device, the customer should always evaluate and test devices mounted in the customer's products or equipment.
- SANYO Semiconductor Co., Ltd. strives to supply high-quality high-reliability products. However, any and all semiconductor products fail with some probability. It is possible that these probabilistic failures could give rise to accidents or events that could endanger human lives, that could give rise to smoke or fire, or that could cause damage to other property. When designing equipment, adopt safety measures so that these kinds of accidents or events cannot occur. Such measures include but are not limited to protective circuits and error prevention circuits for safe design, redundant design, and structural design.
- In the event that any or all SANYO Semiconductor products (including technical data, services) described or contained herein are controlled under any of applicable local export control laws and regulations, such products must not be exported without obtaining the export license from the authorities concerned in accordance with the above law.
- No part of this publication may be reproduced or transmitted in any form or by any means, electronic or mechanical, including photocopying and recording, or any information storage or retrieval system, or otherwise, without the prior written permission of SANYO Semiconductor Co., Ltd.
- Any and all information described or contained herein are subject to change without notice due to product/technology improvement, etc. When designing equipment, refer to the "Delivery Specification" for the SANYO Semiconductor product that you intend to use.
- Information (including circuit diagrams and circuit parameters) herein is for example only; it is not guaranteed for volume production. SANYO Semiconductor believes information herein is accurate and reliable, but no guarantees are made or implied regarding its use or any infringements of intellectual property rights or other rights of third parties.

This catalog provides information as of December, 2006. Specifications and information herein are subject to change without notice.