



SANYO Semiconductors

DATA SHEET

An ON Semiconductor Company

Monolithic Digital IC

LB11961V — Single-Phase Full-Wave Fan Motor Driver

Overview

The LB11961V is a single-phase bipolar drive motor driver that easily implements direct PWM motor drive systems with excellent efficiency. The LB11961V is optimal for fan motor drive in personal computer power supply systems and CPU cooling fan systems.

Features

- Single-phase full-wave drive (16V, 1.0A transistors are built in)
- Built-in variable speed function controlled by a thermistor input
The LB11961V can implement quiet, low-vibration variable speed control using externally clocked high side transistor direct PWM drive.
- Built-in regenerative diode (Di); only requires a minimal number of external components.
- Built-in HB
- Minimum speed setting pin (allows full-speed mode operation at startup)
- Operates in full-speed mode when the thermistor is removed.
- Built-in lock protection and automatic recovery circuits
- FG (speed detection) and RD (lock detection) outputs
- Built-in thermal shutdown circuit

■ Any and all SANYO Semiconductor Co.,Ltd. products described or contained herein are, with regard to "standard application", intended for the use as general electronics equipment. The products mentioned herein shall not be intended for use for any "special application" (medical equipment whose purpose is to sustain life, aerospace instrument, nuclear control device, burning appliances, transportation machine, traffic signal system, safety equipment etc.) that shall require extremely high level of reliability and can directly threaten human lives in case of failure or malfunction of the product or may cause harm to human bodies, nor shall they grant any guarantee thereof. If you should intend to use our products for new introduction or other application different from current conditions on the usage of automotive device, communication device, office equipment, industrial equipment etc. , please consult with us about usage condition (temperature, operation time etc.) prior to the intended use. If there is no consultation or inquiry before the intended use, our customer shall be solely responsible for the use.

■ Specifications of any and all SANYO Semiconductor Co.,Ltd. products described or contained herein stipulate the performance, characteristics, and functions of the described products in the independent state, and are not guarantees of the performance, characteristics, and functions of the described products as mounted in the customer's products or equipment. To verify symptoms and states that cannot be evaluated in an independent device, the customer should always evaluate and test devices mounted in the customer's products or equipment.

SANYO Semiconductor Co., Ltd.

<http://semicon.sanyo.com/en/network>

LB11961V

Specifications

Absolute Maximum Ratings at $T_a = 25^\circ\text{C}$

Parameter	Symbol	Conditions	Ratings	Unit
V_{CC} maximum output voltage	$V_{CC\ max}$		18	V
OUT pin maximum output current	$I_{OUT\ max}$		1.0	A
OUT pin output withstand voltage	$V_{OUT\ max}$		18	V
HB maximum output current	$I_{HB\ max}$		10	mA
VTH input pin voltage	$V_{TH\ max}$		6	V
RD/FG output pin output voltage	$V_{RD/FG\ max}$		18	V
RD/FG maximum output current	$I_{RD/FG\ max}$		10	mA
Allowable power dissipation	$P_d\ max$	When mounted on a circuit board *1	0.8	W
Operating temperature	T_{opr}		-30 to +90	$^\circ\text{C}$
Storage temperature	T_{stg}		-55 to +150	$^\circ\text{C}$

*1 Specified circuit board : $114.3 \times 76.1 \times 1.6\text{mm}^3$, glass epoxy.

Caution 1) Absolute maximum ratings represent the value which cannot be exceeded for any length of time.

Caution 2) Even when the device is used within the range of absolute maximum ratings, as a result of continuous usage under high temperature, high current, high voltage, or drastic temperature change, the reliability of the IC may be degraded. Please contact us for the further details.

Recommended Operating Conditions at $T_a = 25^\circ\text{C}$

Parameter	Symbol	Conditions	Ratings	Unit
V_{CC} supply voltage	V_{CC}		4.5 to 16	V
VTH input level voltage range	VTH		0 to 9	V
Hall sensor input common-mode input voltage range	VICM		0.2 to 3	V

Electrical Characteristics Unless otherwise specified $T_a = 25^\circ\text{C}$, $V_{CC} = 12\text{V}$

Parameter	Symbol	Conditions	Ratings			Unit
			min	typ	max	
Circuit current	I_{CC1}	Drive mode	12	18	24	mA
	I_{CC2}	Lock protection mode	8	11	16	mA
6VREG voltage	V_{6VREG}	$I_{6VREG} = 5\text{mA}$	5.8	6	6.2	V
HB voltage	V_{HB}	$I_{HB} = 5\text{mA}$	1.10	1.25	1.40	V
CPWM high-level voltage	V_{CRH}		3.45	3.6	3.75	V
CPWM low-level voltage	V_{CRL}		1.95	2.05	2.15	V
CPWM oscillator frequency	f_{PWM}	$C = 100\text{pF}$	18	25	32	kHz
CT pin high-level voltage	V_{CTH}		3.45	3.6	3.75	V
CT pin low-level voltage	V_{CTL}		1.55	1.7	1.85	V
ICT charge current	I_{CT1}		1.5	2	2.5	μA
ICT discharge current	I_{CT2}		0.15	0.2	0.25	μA
ICT charge/discharge current ratio	RCT		8.5	10	11.5	
OUT output low saturation voltage	V_{OL}	$I_O = 200\text{mA}$		0.2	0.3	V
OUT output high saturation voltage	V_{OH}	$I_O = 200\text{mA}$		0.9	1.1	V
Hall sensor input sensitivity	VHN	Zero peak value (including offset and hysteresis)		10	20	mV
RD/FG output pin low-level voltage	$V_{RDL/FGL}$	$V_{RD/FG} = 5\text{mA}$		0.2	0.3	V
RD/FG output pin leakage current	$I_{RD/FG}$	$V_{RD/FG} = 7\text{V}$			30	μA

LB11961V

Package Dimensions

unit : mm (typ)
3178B

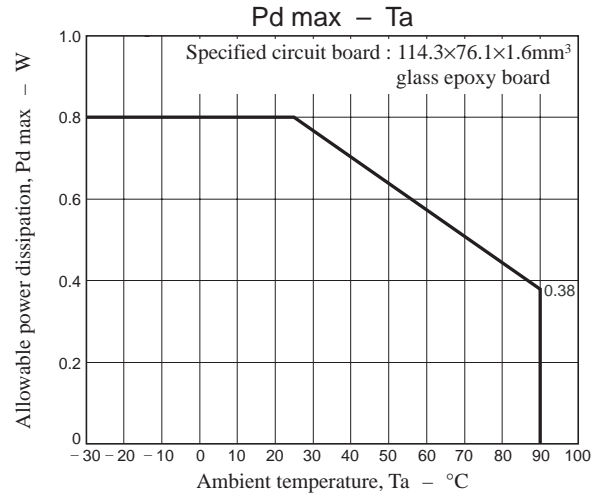
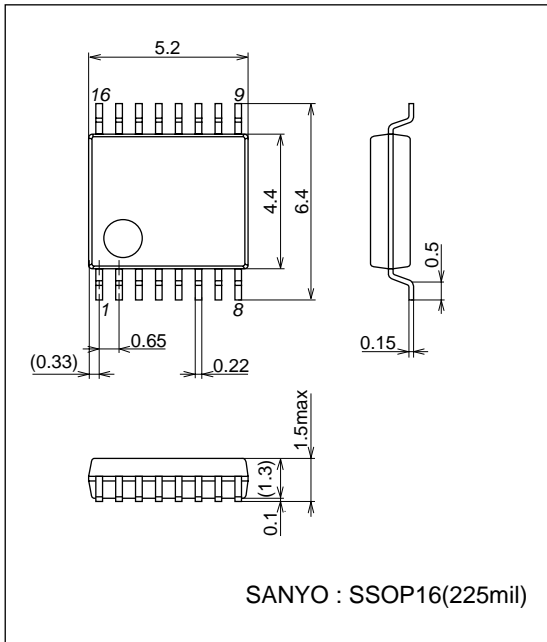

Truth Table

VTH	IN-	IN+	CPWM	CT	OUT1	OUT2	FG	RD	Mode
Low (open)	High	Low	High	Low	High	Low	Low	On	During rotation – drive (PWM off)
	Low	High			Low	High	Off		
High	High	Low	Low		Off	Low	Low		During rotation – regeneration (PWM on)
	Low	High			Low	Off	Off		
-	High	Low	-	High	High	Off	Low	Off	Lock protection
-	Low	High	-		Off	High	Off		

CPWM – High is the state where CPWM > VTH, and CPWM– Low is the state where CPWM < VTH.

Open : The LB11961V operates in full-speed mode when the thermistor is removed.

Pin Assignment

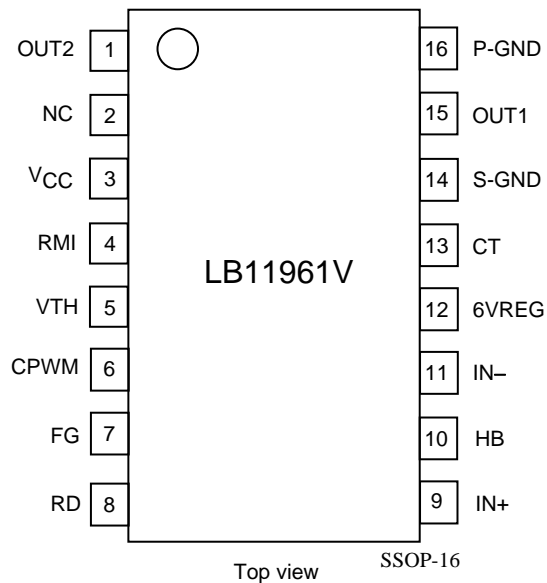

P-GND : Motor system ground

S-GND : Control system ground

LB11961V

Block Diagram

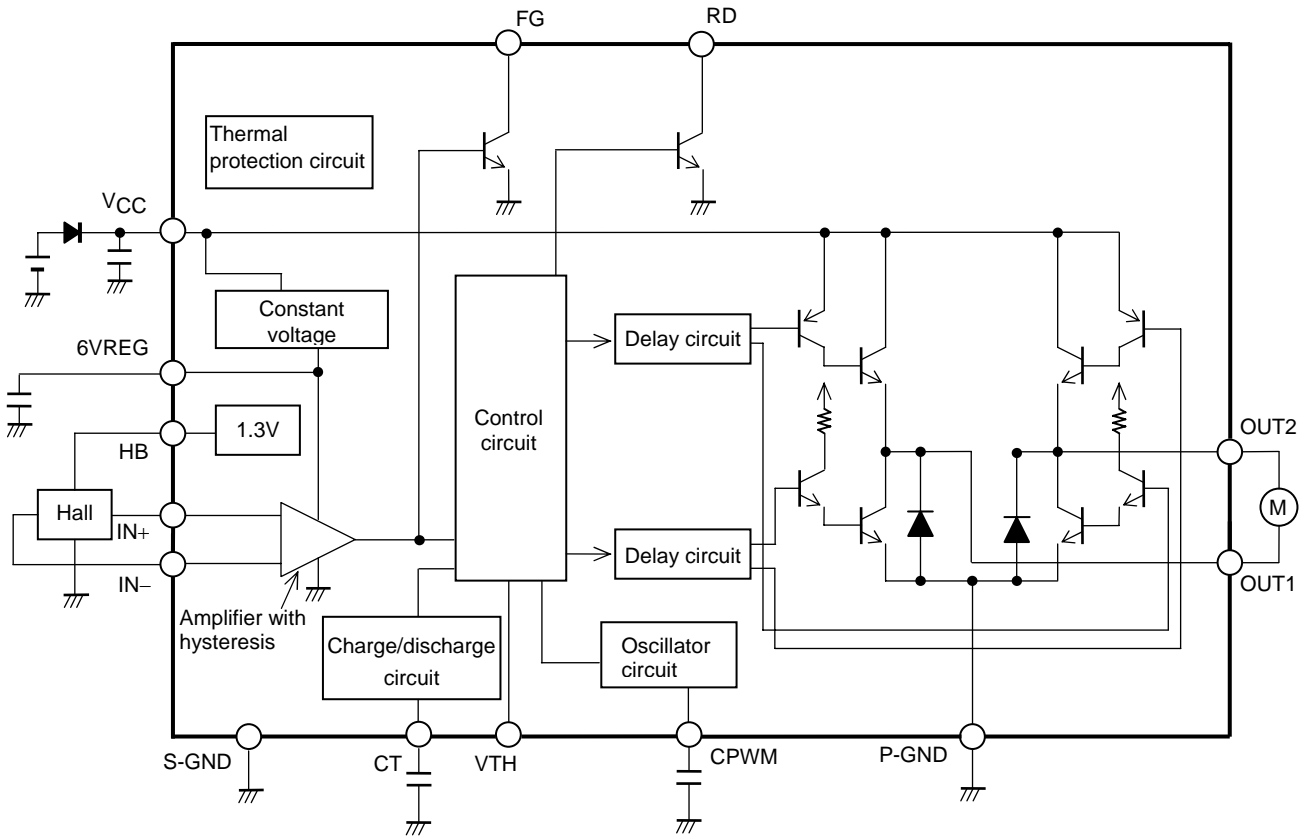

Application Circuit Example

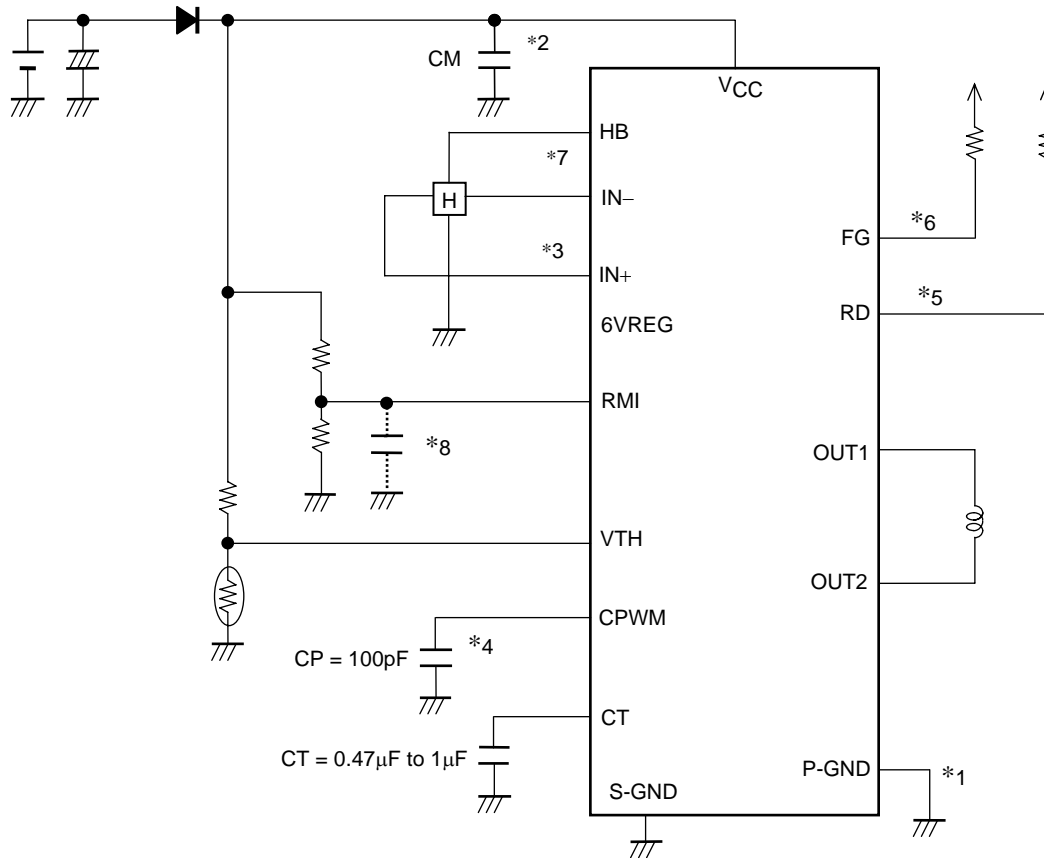

***1. Power supply and ground lines**

P-GND is connected to the motor power supply system and S-GND is connected to the control circuit power supply system. These two systems should be formed from separate lines and the control system external components should be connected to S-GND.

***2. Regeneration power supply stabilization capacitor**

The capacitor CM provides power supply stabilization for both PWM drive and kickback absorption. A capacitor with a value of over 0.1μF is used for CM. A large capacitor must be used when the coil inductance is large or when the coil resistance is low. Since this IC adopts a technique in which switching is performed by the high side transistor and regeneration is handled by the low side transistor, the pattern connecting CM to VM and P-GND must be as wide and as short as possible.

***3. Hall sensor input**

Lines that are as short as possible must be used to prevent noise from entering the system. The Hall sensor input circuit consists of a comparator with hysteresis (20mV). We recommend that the Hall sensor input level be at least three times this hysteresis, i.e. at least 60mVp-p.

***4. PWM oscillator frequency setting capacitor**

If a value of 100pF is used for CP, the oscillator frequency will be $f = 25\text{kHz}$, and this will be the basic frequency of the PWM signal.

***5. RD output**

This is an open collector output. It outputs a low level when the motor is turning and a high level when it is stopped. This pin must be left open if unused.

***6. FG output**

This is an open collector output, and a rotation count detection function can be implemented using this FG output, which corresponds to the phase switching. This pin must be left open if unused.

***7. HB pin**

This pin provides a Hall effect sensor bias constant-voltage output of 1.25V.

***8. RMI pin**

Connect this pin to VTH if unused. Even if unused, the IC is set internally to operate at a 10% drive duty at the voltage corresponding to the lowest speed. (The capacitor is used to set up full-speed mode at startup.)

Control Timing Chart

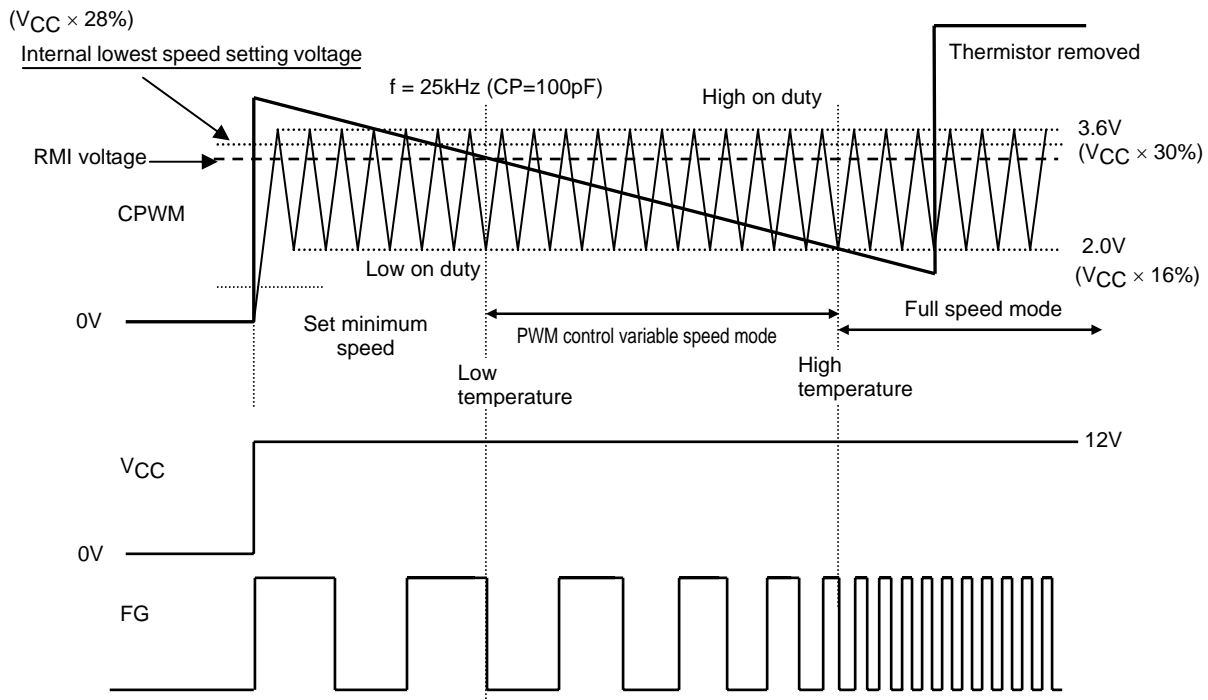

1. **Set minimum speed mode**

A VTH voltage level is generated when the thermistor detects the set temperature. At low temperatures, the fan motor turns at the lowest speed, which is set with the RMI pin. The LB11961V compares the CPWM oscillator voltage with the RMI pin voltage and sets the duty for the lowest drive state.

2. **High speed ↔ low speed mode**

The PWM signal is controlled by comparing the CPWM oscillation voltage that cycles between 1.2V and 3.8V and the VTH voltage.

When the VTH voltage is lower, the high and low side transistors are turned on, and when the VTH voltage is higher, the high side transistor is turned off and the coil current is regenerated through the low side transistor. Thus the output on duty increases as the VTH voltage becomes lower, the coil current increases, and the motor speed increases.

Rotation speed feedback is provided by the FG output.

3. **Full-speed mode**

The LB11961V switches to full-speed mode above a certain temperature.

4. **Thermistor removed mode**

If the thermistor is removed, the VTH input voltage will rise. However, the output will go to full drive at 100% and the motor will run at full speed.

- SANYO Semiconductor Co.,Ltd. assumes no responsibility for equipment failures that result from using products at values that exceed, even momentarily, rated values (such as maximum ratings, operating condition ranges, or other parameters) listed in products specifications of any and all SANYO Semiconductor Co.,Ltd. products described or contained herein.
- SANYO Semiconductor Co.,Ltd. strives to supply high-quality high-reliability products, however, any and all semiconductor products fail or malfunction with some probability. It is possible that these probabilistic failures or malfunction could give rise to accidents or events that could endanger human lives, trouble that could give rise to smoke or fire, or accidents that could cause damage to other property. When designing equipment, adopt safety measures so that these kinds of accidents or events cannot occur. Such measures include but are not limited to protective circuits and error prevention circuits for safe design, redundant design, and structural design.
- In the event that any or all SANYO Semiconductor Co.,Ltd. products described or contained herein are controlled under any of applicable local export control laws and regulations, such products may require the export license from the authorities concerned in accordance with the above law.
- No part of this publication may be reproduced or transmitted in any form or by any means, electronic or mechanical, including photocopying and recording, or any information storage or retrieval system, or otherwise, without the prior written consent of SANYO Semiconductor Co.,Ltd.
- Any and all information described or contained herein are subject to change without notice due to product/technology improvement, etc. When designing equipment, refer to the "Delivery Specification" for the SANYO Semiconductor Co.,Ltd. product that you intend to use.
- Upon using the technical information or products described herein, neither warranty nor license shall be granted with regard to intellectual property rights or any other rights of SANYO Semiconductor Co.,Ltd. or any third party. SANYO Semiconductor Co.,Ltd. shall not be liable for any claim or suits with regard to a third party's intellectual property rights which has resulted from the use of the technical information and products mentioned above.

This catalog provides information as of September, 2011. Specifications and information herein are subject to change without notice.