



**LB1687M**

**3-Phase Brushless Motor Driver**

The LB1687M is a 3-phase brushless motor driver IC ideally suited for use in VCR capstan motor, drum motor drive applications.

**Features and Functions**

- (1) 120° voltage linear type
- (2) Soft switching type eliminating noises caused by current switching and making the value of external capacitors smaller (comparable to those of chip capacitors)
- (3) On-chip FG amplifier
- (4) On-chip thermal shutdown circuit
- (5) FG signal can be used to detect the rotational speed of a motor so that the hall amp gain is changed in two steps, thus reducing torque ripple and noise.
- (6) Motor drivable at voltage down to motor supply voltage 5 V

**Absolute Maximum Ratings at Ta=25°C**

		unit
Maximum Supply Voltage	V <sub>CC1</sub> max	20 V
	V <sub>CC2</sub> max	7.0 V
Output Voltage	V <sub>OUT.V.W</sub>	22 V
Output Current	I <sub>OUT</sub>	1.5 A
Allowable Power Dissipation	P <sub>d</sub> max	1.05 W
Operating Temperature	T <sub>opr</sub>	-20 to +75 °C
Storage Temperature	T <sub>stg</sub>	-55 to +125 °C

**Allowable Operating Conditions at Ta=25°C**

		unit
Supply Voltage Range	V <sub>CC1</sub>	5 to 18 V
	V <sub>CC2</sub>	4.3 to 6.5 V

**Package Dimensions 3073A-M301C**  
(unit: mm)

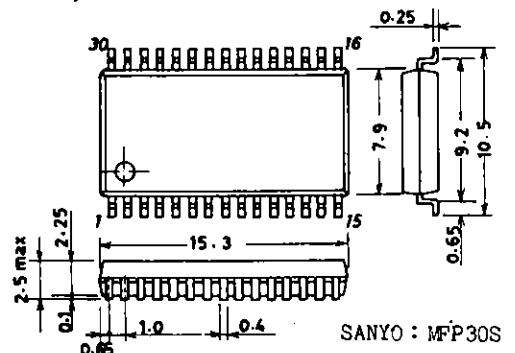

**SANYO Electric Co., Ltd. Semiconductor Business Headquarters**  
TOKYO OFFICE Tokyo Bldg., 1-10, 1 Chome, Ueno, Taito-ku, TOKYO, 110 JAPAN

# LB1687M

**Electrical Characteristics at Ta=25°C, V<sub>CC1</sub>=12V, V<sub>CC2</sub>=5V**

			min	typ	max	unit	Note
<b>[Power Supply]</b>							
Supply Current 1	I <sub>CC1</sub>	V <sub>C</sub> =0, R <sub>L</sub> =∞		17	30	mA	
Supply Current 2	I <sub>CC2</sub>	V <sub>C</sub> =0	6.5	9.5		mA	
<b>[Output]</b>							
Output Saturation Voltage	V <sub>O</sub> (sat)1	I <sub>OUT</sub> =0.5A, Sink+Source		1.6	2.2	V	
	V <sub>O</sub> (sat)2	I <sub>OUT</sub> =1.0A, Sink+Source		2.0	3.0	V	
Output TRS Withstand Voltage	V <sub>O</sub> (sus)	I <sub>OUT</sub> =20mA	20			V	※
Output Static Voltage	V <sub>OQ</sub>	V <sub>C</sub> =0	5.8	6.1	6.4	V	
<b>[Hall Input-Output]</b>							
Hall Amp Input Offset Voltage	V <sub>H</sub> offset		-5		+5	mV	
Hall Amp Input Bias Current	V <sub>H</sub> bias			1	5	μA	
Hall Amp Common-Mode Input Voltage Range	V <sub>H</sub> ch		1.3		3.7	V	
Hall Input-Output Voltage Gain	G <sub>VHO1</sub>			56		dB	
	G <sub>VHO2</sub>			43		dB	
<b>[Control-Output]</b>							
Control Amp Input Impedance							
Control-Output Drive Gain	G <sub>VCO</sub>		38	41	44	dB	
Control-Output CH Difference	Δ G <sub>VCO</sub>		-2		2	dB	
<b>[FG Amp]</b>							
FG Amp Input Offset Voltage	V <sub>FG</sub> offset		-8		+8	mV	
Open Loop Voltage Gain	G <sub>VFG</sub>	f=1kHz		60		dB	
Source Output Saturation Voltage	V <sub>FG</sub> OU	I <sub>O</sub> =2mA	3.7			V	
Sink Output Saturation Voltage	V <sub>FG</sub> OD	I <sub>O</sub> =-2mA			1.3	V	
Common-Mode Signal Rejection Ratio	CHR			80		dB	※
FG Amp Common-Mode Input Voltage Range	V <sub>FG</sub> CH		0		3.5	V	
Phase Margin				20		deg	※
<b>[Motor Detection]</b>							
Motor Detection Amp Hysteresis Width			35	50	65	mV	
CR Pin Threshold Voltage		V <sub>CR</sub> low to high	2.35	2.5	2.65	V	
<b>[Thermal Shutdown]</b>							
Thermal Shutdown Temperature	T <sub>SD</sub>		150	180	210	°C	※
Thermal Shutdown Hysteresis	Δ T <sub>SD</sub>			15		°C	※

Note: ※ indicates design goals not measured values.

## Pin Assignment

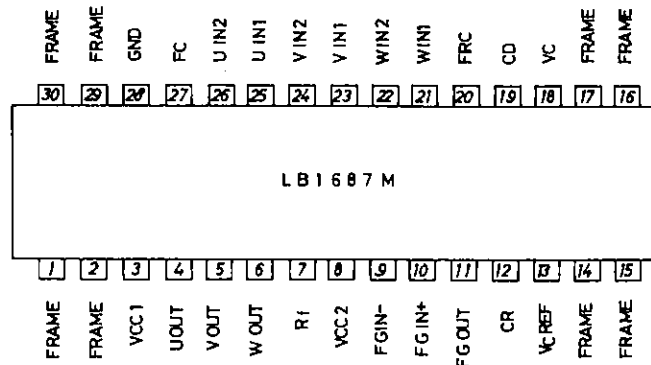

Note: All FRAME pins are connected to GND.

Truth Table

Item	Source → sink	Input			Forward/ reverse control
		U	V	W	
1	W phase → V phase	H	H	L	L
	V phase → W phase				H
2	W phase → U phase	H	L	L	L
	U phase → W phase				H
3	V phase → W phase	L	L	H	L
	W phase → V phase				H
4	U phase → V phase	L	H	L	L
	V phase → U phase				H
5	V phase → U phase	H	L	H	L
	U phase → V phase				H
6	U phase → W phase	L	H	H	L
	W phase → U phase				H

Input: High: Each phase input 1 is more than 0.2V higher than each phase input 2.

Low: Each phase input 1 is more than 0.2V lower than each phase input 2.

Forward/reverse control:  
High: 2.0V to V<sub>CC2</sub>  
Low: 0 to 0.3 V

Pin Description

Pin	Pin No.	Functions
U <sub>IN1</sub> , U <sub>IN2</sub> V <sub>IN1</sub> , V <sub>IN2</sub> W <sub>IN1</sub> , W <sub>IN2</sub>	25, 26 23, 24 21, 22	U phase Hall element input pin; 'H' of logic; V <sub>IN1</sub> > V <sub>IN2</sub> V phase Hall element input pin; 'H' of logic; V <sub>IN1</sub> > V <sub>IN2</sub> W phase Hall element input pin; 'H' of logic; V <sub>IN1</sub> > V <sub>IN2</sub>
U <sub>OUT</sub> V <sub>OUT</sub> W <sub>OUT</sub>	4 5 6	U phase output pin V phase output pin W phase output pin
V <sub>CC1</sub>	3	Power supply pin for applying output
V <sub>CC2</sub>	8	Power supply pin for applying voltage section other than output section; this voltage must be stabilized to be free from ripple, noise, etc.
R <sub>f</sub>	7	Output current detect pin; by connecting R <sub>f</sub> across this pin and ground, output current is detected as voltage. The result is used to control the overcurrent protection circuit.
C <sub>D</sub>	19	Pin for fetching current (voltage) detected with R <sub>f</sub> ; to take feed back for R <sub>f</sub> , the control-output voltage gain can be reduced; when not using, ground.
F <sub>C</sub>	27	Frequency characteristic correction pin
V <sub>C</sub>	18	Speed-phase control pin Control is of voltage-controlled type that controls output voltage.
V <sub>CREF</sub>	13	Control reference voltage.
GND	28	Ground except for output The minimum output transistor potential is at R <sub>f</sub> pin.
F/RC	20	Forward/reverse control pin By setting this pin to high (more than 2 V) or low (less than 0.3 V), truth value is changed to perform forward and reverse rotation.
FG <sub>in-</sub> , FG <sub>in+</sub>	9,10	FG signal input pin
FG <sub>OUT</sub>	11	FG amp output pin
CR	12	The voltage at this pin can be used to change the hall input gain. Connection of an external resistor and capacitor makes it possible to detect the rotational speed of a motor and change the hall input-output voltage gain in two steps.

# LB1687M

## Equivalent Circuit Block Diagram

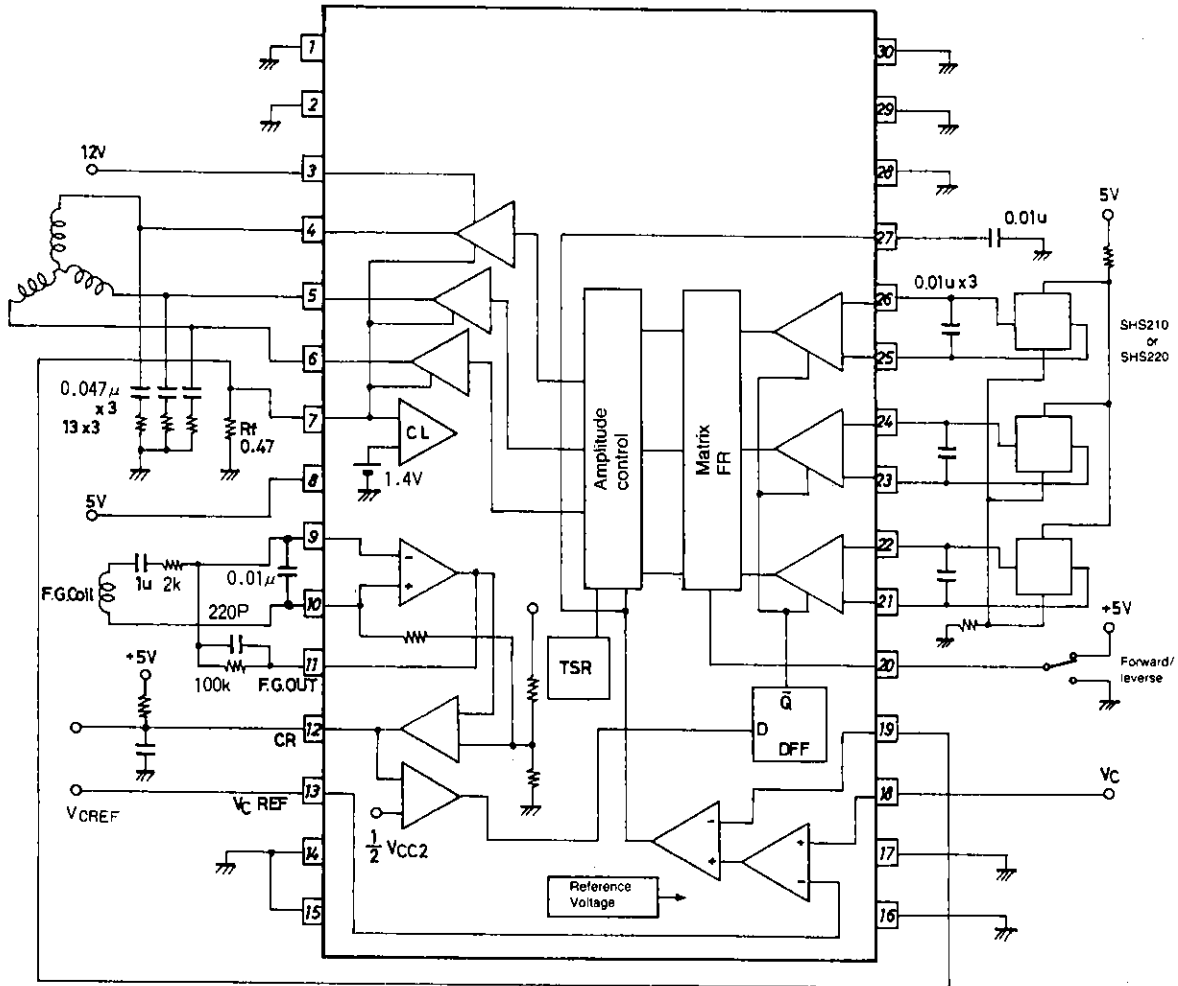

Unit (resistance:  $\Omega$ , capacitance: F)

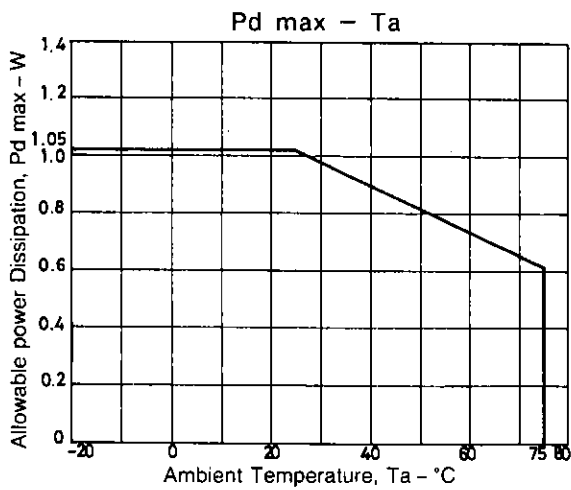

- No products described or contained herein are intended for use in surgical implants, life-support systems, aerospace equipment, nuclear power control systems, vehicles, disaster/crime-prevention equipment and the like, the failure of which may directly or indirectly cause injury, death or property loss.
- Anyone purchasing any products described or contained herein for an above-mentioned use shall:
  - ① Accept full responsibility and indemnify and defend SANYO ELECTRIC CO., LTD., its affiliates, subsidiaries and distributors and all their officers and employees, jointly and severally, against any and all claims and litigation and all damages, cost and expenses associated with such use:
  - ② Not impose any responsibility for any fault or negligence which may be cited in any such claim or litigation on SANYO ELECTRIC CO., LTD., its affiliates, subsidiaries and distributors or any of their officers and employees jointly or severally.
- Information (including circuit diagrams and circuit parameters) herein is for example only; it is not guaranteed for volume production. SANYO believes information herein is accurate and reliable, but no guarantees are made or implied regarding its use or any infringements of intellectual property rights or other rights of third parties.