

SANYO

No. 3782A

LB1810M

**Spindle Motor Driver
for Floppy-disk Drives**

OVERVIEW

The LB1810M is a three-phase, full-wave spindle motor driver IC that features digital speed control, making it ideal for use in 3.5-inch floppy-disk drives. It can be used in most disk drives without output electrolytic capacitors.

The LB1810M incorporates both active-HIGH and active-LOW start/stop control inputs, a revolution detector, Hall-effect transducer amplifiers with AGC, thermal protection and index delay circuits, and a single-sided hysteresis index comparator.

The LB1810M operates from either a 4.2 to 6.5 V or 10.2 to 13.8 V supply and is available in 44-pin QIPs.

FEATURES

- Three-phase, full-wave motor driver
- Digital speed control
- Both active-HIGH and active-LOW start/stop control inputs
- Revolution detector
- Hall-effect transducer amplifiers with AGC
- Thermal protection circuit
- Single-sided hysteresis index comparator
- Index delay circuit
- 4.2 to 6.5 V or 10.2 to 13.8 V supply
- 44-pin QIP

PINOUT

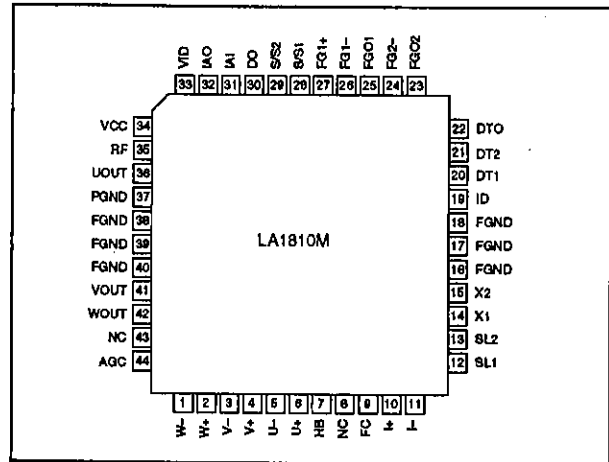

PACKAGE DIMENSIONS

Unit: mm

3148-QIP44MA

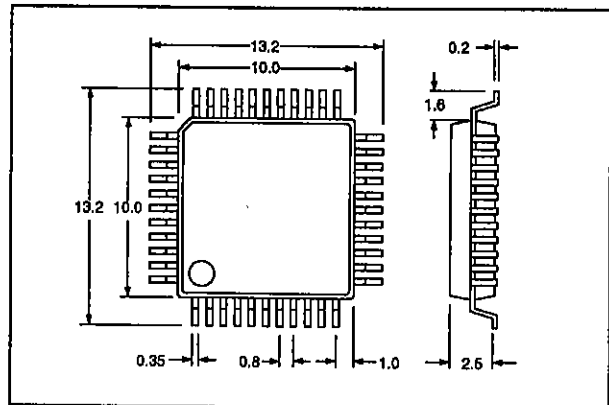

BLOCK DIAGRAM

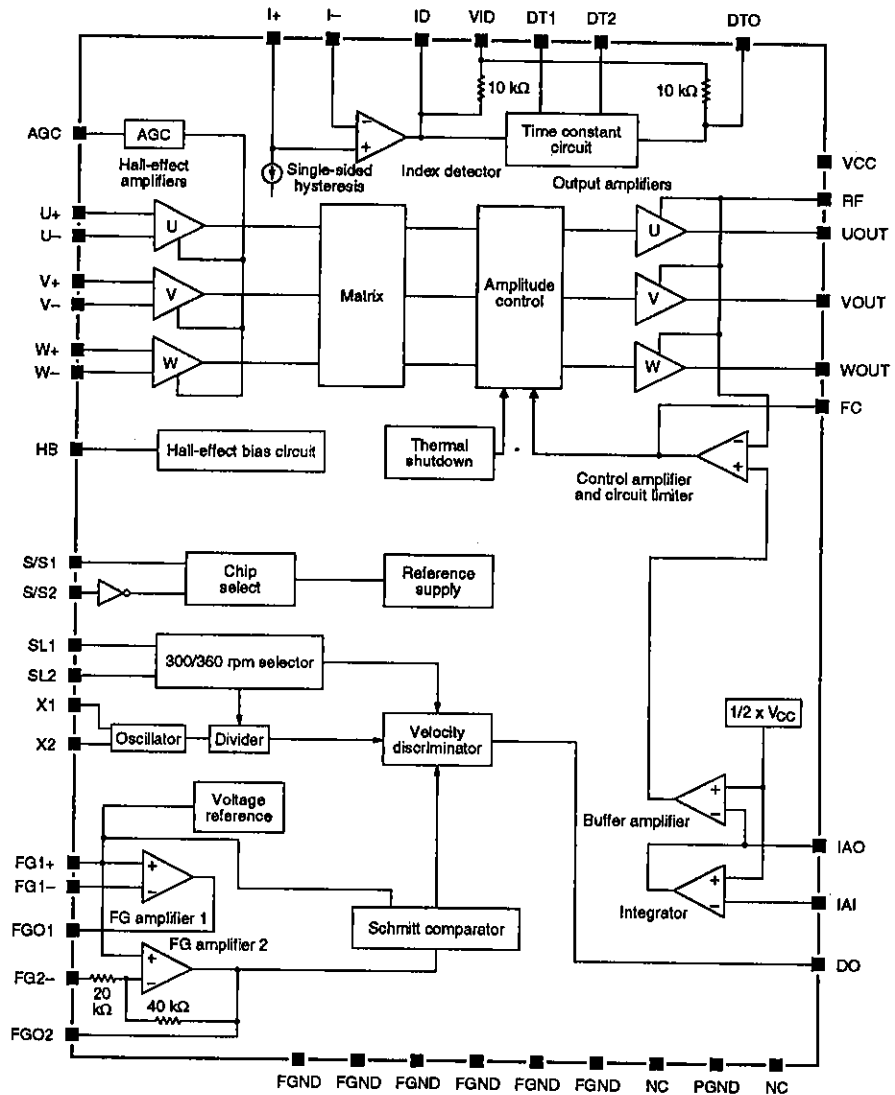

PIN DESCRIPTION

Number	Name	Description
1	W-	W-phase Hall-effect transducer amplifier inputs
2	W+	
3	V-	V-phase Hall-effect transducer amplifier inputs
4	V+	
5	U-	U-phase Hall-effect transducer amplifier inputs
6	U+	
7	HB	Hall-effect transducer bias voltage output
8, 43	NC	No connection
9	FC	Frequency compensation capacitor connection
10	I+	Index detector Hall-effect transducer amplifier inputs
11	I-	

LB1810M

Number	Name	Description
12	SL1	300/360 rpm speed select inputs
13	SL2	
14	X1	Crystal oscillator connections
15	X2	
16 to 18 and 38 to 40	FGND	Frame ground
19	ID	Index pulse output
20	DT1	Delay time-constant setting external network connections
21	DT2	
22	DT0	Index delay pulse output
23	FGO2	FG amplifier 2 output
24	FG2-	FG amplifier 2 inverting input
25	FGO1	FG amplifier 1 output
26	FG1-	FG amplifier 1 inverting input
27	FG1+	FG amplifier 1 non-inverting input
28	S/S1	Start/stop circuit control inputs
29	S/S2	
30	DO	Discriminator output
31	IAI	Integrating amplifier input
32	IAO	Integrating amplifier output
33	VID	5 V index delay circuit supply
34	VCC	4.2 to 6.5 V or 10.2 to 13.8 V supply
35	RF	Output amplifier supply
36	UOUT	U-phase output
37	PGND	Power ground
41	VOUT	V-phase output
42	WOUT	W-phase output
44	AGC	Automatic gain control circuit capacitor connection

SPECIFICATIONS

Absolute Maximum Ratings

Parameter	Symbol	Rating	Unit
Supply voltage	V_{CC}	14.5	V
Output current	I_o	1 ($t \leq 0.5$ s)	A
		0.7	
Power dissipation	P_D	1000	mW
Operating temperature range	T_{opr}	-20 to 80	°C
Storage temperature range	T_{stg}	-40 to 125	°C

LB1810M

Recommended Operating Conditions

$T_a = 25\text{ }^\circ\text{C}$

Parameter	Symbol	Rating	Unit
Supply voltage	V_{CC}	5 or 12	V
Supply voltage range	V_{CC}	4.2 to 6.5 or 10.2 to 13.8	V

Electrical Characteristics

$V_{CC} = 12\text{ V}$, $T_a = 25\text{ }^\circ\text{C}$ unless otherwise noted

Parameter	Symbol	Condition	Rating			Unit
			min	typ	max	
Quiescent supply current	I_{CCO}	$V_{CC} = 5\text{ V}$, motor stopped	-	-	0.2	mA
		$V_{CC} = 12\text{ V}$, motor stopped	-	-	0.5	
Supply current	I_{CC}	$V_{CC} = 5\text{ V}$, motor running	-	20	30	mA
		$V_{CC} = 12\text{ V}$, motor running	-	22	33	
SL1 and SL2 360-rpm select input voltage	V_{SLL}		0	-	0.8	V
SL1 and SL2 300-rpm select input voltage	V_{SLH}		2	-	V_{CC}	V
SL1 and SL2 input bias current	I_{SL}		-	-	0.4	mA
S/S1 stop voltage	$V_{S/S1L}$		0	-	0.8	V
S/S1 start voltage	$V_{S/S1H}$		2	-	V_{CC}	V
S/S1 input bias current	$I_{S/S1}$		-	-	0.4	mA
S/S2 start voltage	$V_{S/S2L}$		0	-	0.8	V
S/S2 stop voltage	$V_{S/S2H}$		2	-	V_{CC}	V
Hall-effect transducer amplifier common-mode input voltage	V_H		2.2	-	$V_{CC} - 0.7$	V
Hall-effect transducer amplifier differential input voltage	V_{df}		70	-	200	mV _{pp}
Hall-effect transducer amplifier input offset voltage	V_{ho}	See note.	-	-	± 10	mV
Hall-effect transducer amplifier input bias current	I_{HB}		-	-	20	μA
HB output voltage	V_H	$I_H = 5\text{ mA}$	-	1.5	1.8	V
HB output leakage current	I_{HL}	Motor stopped	-	-	± 10	μA
UOUT, VOUT and WOUT source or sink output saturation voltage	V_{sat}	$I_o = 0.35\text{ A}$, $V_{CC} = 4.2\text{ V}$	-	1.2	1.4	V
		$I_o = 0.7\text{ A}$, $V_{CC} = 4.2\text{ V}$	-	1.5	2.0	V
UOUT, VOUT and WOUT output leakage current	I_{OL}		-	-	± 1	mA
Current limiter reference voltage	V_{ref1}		0.27	0.30	0.33	V
Control amplifier voltage gain	G_C		-	-6	-	dB
Control amplifier interphase voltage gain differential	ΔG_C		-	-	± 1	dB
Integrating amplifier reference voltage	V_{ref2}		-	$0.5V_{CC}$	-	V
Integrating amplifier bias current	I_b		-	-	± 1	μA

LB1810M

Parameter	Symbol	Condition	Rating			Unit
			min	typ	max	
Integrating amplifier output voltages	V_{I+}	Referenced to V_{ref2} , $I_i = -0.5$ mA	-	0.75	-	V
	V_{I-}	Referenced to V_{ref2} , $I_i = 0.5$ mA	-	-1.4	-	V
Amplifier gain bandwidth	BW	See note.	-	1	-	MHz
FG amplifier 1 input voltage	V_{FG1}		2	-	40	mV _{pp}
FG amplifier 1 voltage gain	G_{FG1}	Output open. See note.	-	60	-	dB
FG amplifier 1 input offset voltage	V_{FG1O}		-	-	± 10	mV
FG amplifier 2 input voltage	V_{FG2}		1	-	$V_{CC} - 1$	V
FG amplifier 2 voltage gain	G_{FG2}		-	6	-	dB
FG amplifier 2 input offset voltage	V_{FG2O}		-	-	± 10	mV
FG amplifiers internal reference voltage	V_{FGB}	$V_{CC} = 5$ V	2.2	2.5	2.8	V
		$V_{CC} = 12$ V	5.3	5.9	6.5	
Schmitt-trigger voltage hysteresis	ΔV_{sh}	LOW-to-HIGH and HIGH-to-LOW. See note.	-	25	-	mV
Schmitt-trigger input voltage	V_{sh}		1	-	$V_{CC} - 1$	V
Discriminator levels	N		-	1024	-	levels
Discriminator LOW-level voltage	V_{DL}	$I_D = -0.5$ mA	-	-	0.3	V
Discriminator HIGH-level voltage	V_{DH}	$I_D = 0.5$ mA	$V_{CC} - 0.4$	-	-	V
Discriminator leakage current	I_{D1}		-	-	± 1	μ A
Discriminator operating frequency	f_D	See note.	-	-	1	MHz
Oscillator frequency	f_{osc}	See note.	-	-	1	MHz
Index detector Hall-effect transducer amplifier phase input voltage	V_{ID}		1.5	-	$V_{CC} - 0.5$	V
Index detector Hall-effect transducer amplifier input bias current	I_{IDB}		-	-	± 10	μ A
Induction current for hysteresis	I_{IDO}		5	10	15	μ A
Index detector LOW-level output voltage	V_{IDL}	$V_{ID} = 5$ V	-	-	0.4	V
Index detector HIGH-level output voltage	V_{IDH}	$V_{ID} = 5$ V	4.5	-	-	V
Index delay circuit discharge voltage	V_{DLDC}	$V_{ID} = 5$ V	-	2.5	-	V
Index delay circuit LOW-level output voltage	V_{DLL}	$V_{ID} = 5$ V	-	-	0.4	V
Index delay circuit HIGH-level output voltage	V_{DLH}	$V_{ID} = 5$ V	4.5	-	-	V
Thermal shutdown temperature	TSD	See note.	150	180	-	$^{\circ}$ C
Thermal shutdown temperature hysteresis	ΔTSD	See note.	-	40	-	$^{\circ}$ C

Note

These values are calculated ratings only and are not measured.

Typical Performance Characteristics

Maximum power dissipation vs. ambient temperature

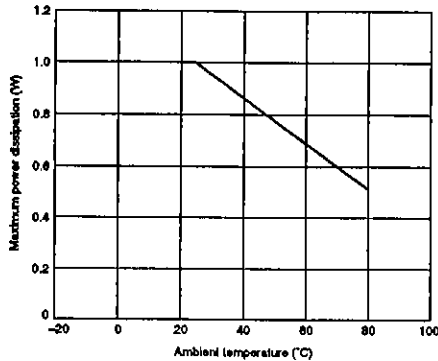

FUNCTIONAL DESCRIPTION

Digital Speed Control

The motor speed is given by the equation

$$f_{FG} = \frac{f_{osc} \times D}{1024}$$

where f_{FG} is the revolution detector frequency, f_{osc} is the crystal oscillator frequency and D is the frequency-divider constant. When SL1 is HIGH, D is 5/8, and when LOW, D is 6/8.

Output Phase Control

The motor driver output source and sink phases are selected by the voltages on the Hall-effect transducer amplifier inputs for each phase as shown in table 1. Note that a Hall-effect transducer amplifier input is HIGH when the voltage on the positive input exceeds the voltage on the negative input.

Table 1. Source and sink phase selection

Source phase	Sink phase	Hall-effect transducer amplifier inputs		
		U	V	W
V	W	HIGH	HIGH	LOW
V	U	LOW	HIGH	LOW
W	U	LOW	HIGH	HIGH
W	V	LOW	LOW	HIGH
U	V	HIGH	LOW	HIGH
U	W	HIGH	LOW	LOW

TYPICAL APPLICATION

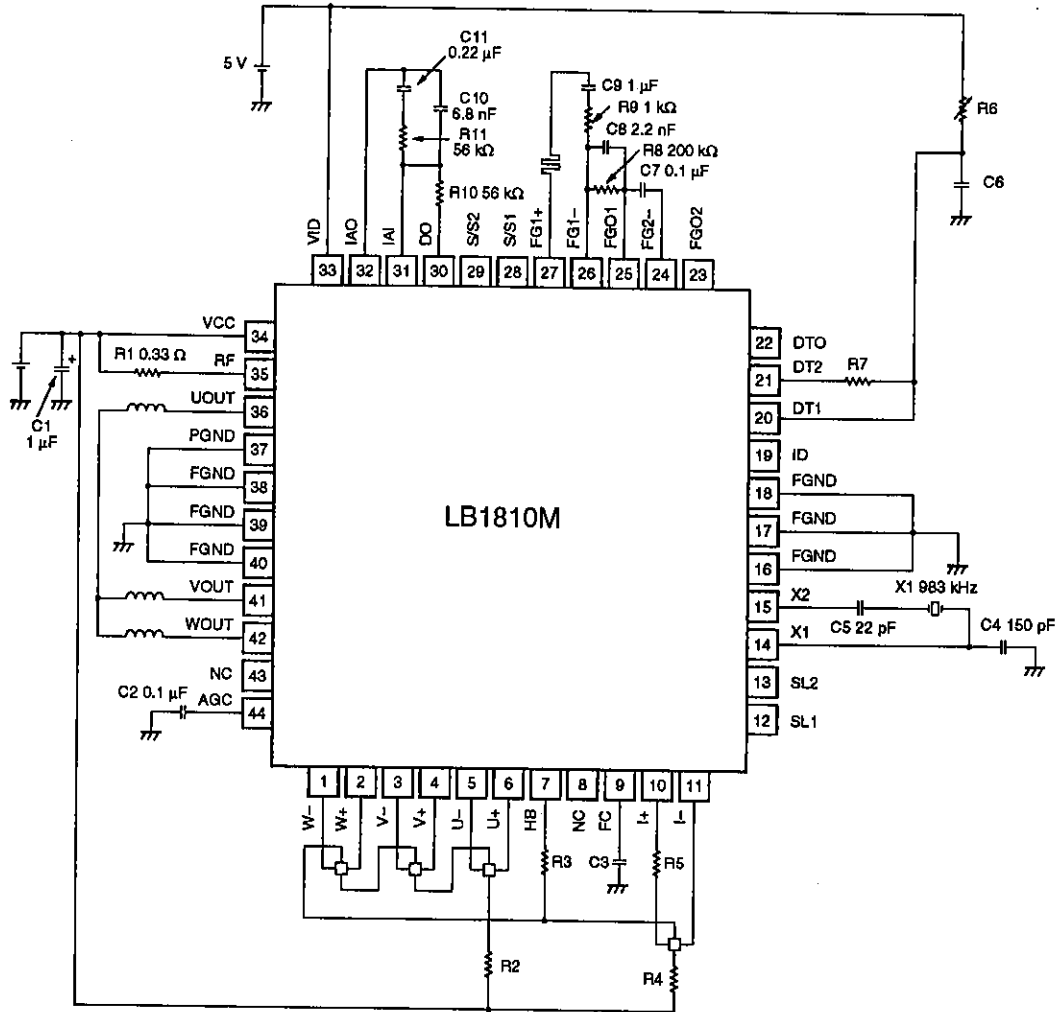

Note

Component values are for example only. Exact values will depend upon the motor characteristics.

- No products described or contained herein are intended for use in surgical implants, life-support systems, aerospace equipment, nuclear power control systems, vehicles, disaster/crime-prevention equipment and the like, the failure of which may directly or indirectly cause injury, death or property loss.
- Anyone purchasing any products described or contained herein for an above-mentioned use shall:
 - ① Accept full responsibility and indemnify and defend SANYO ELECTRIC CO., LTD., its affiliates, subsidiaries and distributors and all their officers and employees, jointly and severally, against any and all claims and litigation and all damages, cost and expenses associated with such use;
 - ② Not impose any responsibility for any fault or negligence which may be cited in any such claim or litigation on SANYO ELECTRIC CO., LTD., its affiliates, subsidiaries and distributors or any of their officers and employees jointly or severally.
- Information (including circuit diagrams and circuit parameters) herein is for example only; it is not guaranteed for volume production. SANYO believes information herein is accurate and reliable, but no guarantees are made or implied regarding its use or any infringements of intellectual property rights or other rights of third parties.