

SANYO

No. 4183A

LB1813M**Spindle Motor Driver for Floppy-disk Drives**

Overview

The LB1813M is a three-phase, full-wave spindle motor driver IC that features digital speed control, making it ideal for use in 3.5-inch floppy disk drives. It can be used in most disk drives without requiring any output electrolytic capacitors.

The LB1813M incorporates a start/stop control input, a revolution detector, Hall-effect transducer amplifiers with AGC, thermal protection and index delay circuits, and a single-sided hysteresis index comparator.

The LB1813M operates from a 4.2 to 6.5 V supply and is available in 36-pin MFPs.

Features

- Three-phase, full-wave motor driver
- Digital speed control
- Start/stop control input
- Revolution detector
- Hall-effect transducer amplifiers with AGC
- Thermal protection circuit
- Current limiter circuit
- Single-sided hysteresis index comparator
- Index delay circuit
- 4.2 to 6.5 V supply
- 36-pin MFP

Pin Assignment

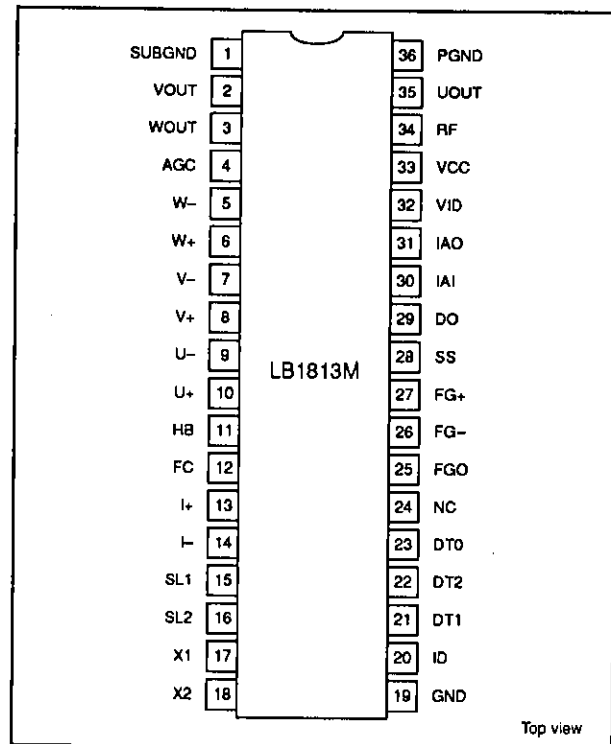

Package Dimensions

Unit: mm

3129-MFP36S

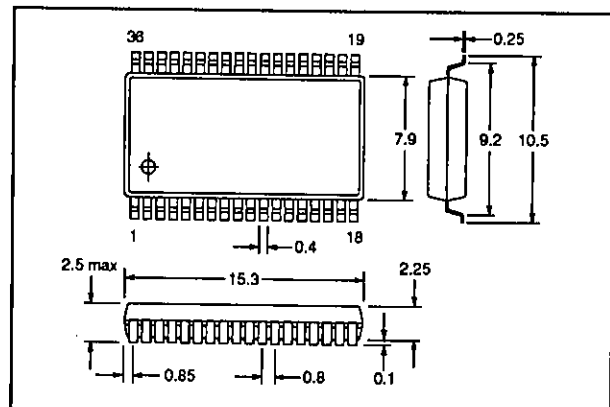

Block Diagram

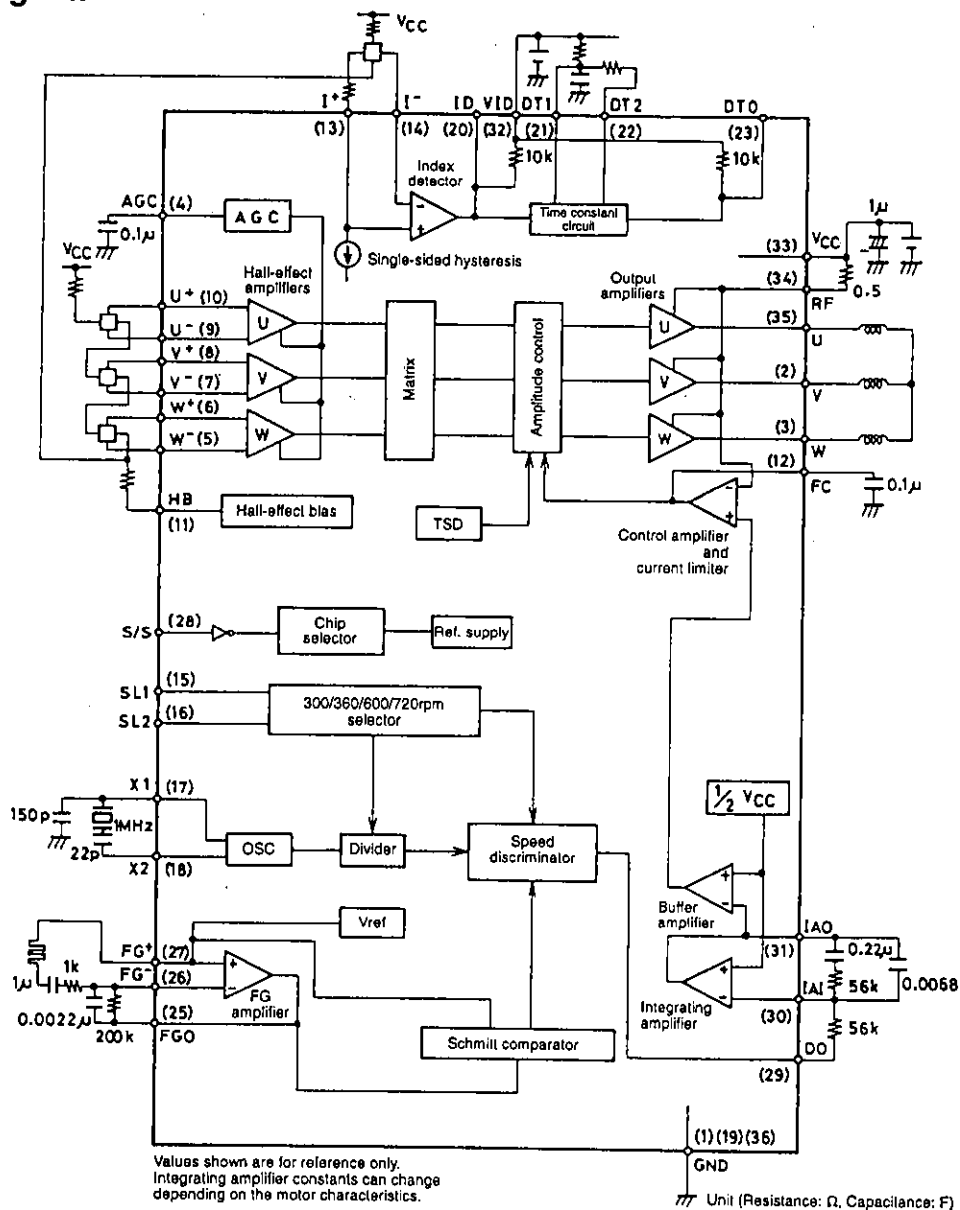

Pin Functions

Number	Name	Equivalent circuit	Function
1	SGND		Sub-ground
2	VOUT		V-phase output
3	WOUT		W-phase output
4	AGC		Automatic gain control circuit capacitor connection

LB1813M

Number	Name	Equivalent circuit	Function :
5	W-		W-phase Hall-effect transducer amplifier inputs. HIGH when $W+ > W-$.
6	W+		V-phase Hall-effect transducer amplifier inputs. HIGH when $V+ > V-$.
7	V-		U-phase Hall-effect transducer amplifier inputs. HIGH when $U+ > U-$.
8	V+		
9	U-		
10	U+		
11	HB		Hall-effect transducer bias voltage output. When in stop mode, HB is open.
12	FC		Frequency compensation capacitor connection
13	I+		Index detector Hall-effect transducer amplifier inputs. When $I+$ is HIGH, $I_1 = 10 \mu\text{A}$. When $I+$ is LOW, $I_1 = 0 \mu\text{A}$. The hysteresis width is determined by the external resistor connected to $I+$.
14	I-		
15	SL1		RPM select input 1
16	SL2		RPM select input 2

LB1813M

Number	Name	Equivalent circuit	Function
17	X1		Crystal oscillator connection 1
18	X2		Crystal oscillator connection 2
19	GND		Ground
20	ID		Index pulse output
21	DT1		Delay time constant setting external network connection 1
22	DT2		Delay time constant setting external network connection 2
23	DTO		Index delay pulse output
24	NC		No connection

LB1813M

Number	Name	Equivalent circuit	Function :
25	FGO		FG amplifier output
26	FG-		FG amplifier inverting input
27	FG+		FG amplifier non-inverting input
28	S/S		Active LOW start/stop circuit control input.
29	DO		Discriminator output
30	IAI		Integrating amplifier input
31	IAO		Integrating amplifier output
32	VID		5 V index delay circuit supply
33	VCC		4.2 to 6.5 V supply
34	RF		Output supply voltage detection input. Connecting a resistor between RF and VCC enables current limiting.

LB1813M

Number	Name	Equivalent circuit	Function :
35	UOUT		U-phase output
36	PGND		Power ground

Specifications

Absolute Maximum Ratings

Parameter	Symbol	Ratings	Unit
Supply voltage	V_{CC}	7.0	V
Output current	I_o	1 ($t \leq 0.5$ s)	A
		0.7	
Power dissipation	P_D	1000	mW
Operating temperature range	T_{opr}	-20 to 80	°C
Storage temperature range	T_{stg}	-40 to 150	°C

Allowable Operating Ranges

$T_a = 25$ °C

Parameter	Symbol	Ratings	Unit
Supply voltage	V_{CC}	5	V
Supply voltage range	V_{CC}	4.2 to 6.5	V

Electrical Characteristics

$V_{CC} = 5$ V, $T_a = 25$ °C unless otherwise noted

Parameter	Symbol	Conditions	Ratings			Unit
			min	typ	max	
Quiescent supply current	I_{CCO}	Motor stopped	-	-	0.4	mA
Supply current	I_{CC}	Motor running	-	20	30	mA
SL1 and SL2 360-rpm select input voltage	V_{SLL}		0	-	0.8	V
SL1 and SL2 300-rpm select input voltage	V_{SLH}		2	-	V_{CC}	V
SL1 and SL2 input bias current	I_{SL}		-	-	0.4	mA
S/S start voltage	$V_{S/SL}$		0	-	0.8	V
S/S stop voltage	$V_{S/SH}$		2	-	V_{CC}	V
S/S input bias current	$I_{S/S}$		-	-	0.1	mA
Hall-effect transducer amplifier common-mode input voltage	V_h		2.2	-	$V_{CC} - 0.7$	V
Hall-effect transducer amplifier differential input voltage	V_{dit}		70	-	200	mV _{pp}

LB1813M

Parameter	Symbol	Conditions	Ratings			Unit
			min	typ	max	
Hall-effect transducer amplifier input offset voltage	V_{ho}	See Note.	-	-	± 10	mV
Hall-effect transducer amplifier input bias current	I_{HB}		-	-	20	μA
HB output voltage	V_H	$I_H = 5 \text{ mA}$	-	1.5	1.8	V
HB output leakage current	I_{HL}	Motor stopped	-	-	± 10	μA
UOUT, VOUT and WOUT source or sink output saturation voltage	V_{sat}	$I_o = 0.35 \text{ A}, V_{cc} = 4.2 \text{ V}$	-	1.2	1.4	V
		$I_o = 0.7 \text{ A}, V_{cc} = 4.2 \text{ V}$	-	1.5	2.0	V
UOUT, VOUT and WOUT output leakage current	I_{oL}		-	-	± 1	mA
Current limiter reference voltage	V_{ref1}		0.27	0.30	0.33	V
Control amplifier voltage gain	G_C		-	-6	-	dB
Control amplifier interphase voltage gain differential	ΔG_C		-	-	± 1	dB
Integrating amplifier reference voltage	V_{ref2}		-	$0.5V_{cc}$	-	V
Integrating amplifier bias current	I_b		-	-	± 1	μA
Integrating amplifier output voltages	V_i^+	Referenced to V_{ref2} , $I_i = -0.5 \text{ mA}$	-	0.75	-	V
	V_i^-	Referenced to V_{ref2} , $I_i = 0.5 \text{ mA}$	-	-1.4	-	V
Amplifier gain bandwidth	BW	See Note.	-	1	-	MHz
FG amplifier input voltage	V_{FG}		5	-	100	mV_{pp}
FG amplifier voltage gain	G_{FG}	Output open. See Note.	-	60	-	dB
FG amplifier input offset voltage	V_{FGO}		-	-	± 10	mV
FG amplifier internal reference voltage	V_{FGB}		2.2	2.5	2.8	V
Schmitt trigger voltage hysteresis	ΔV_{sh}	LOW-to-HIGH and HIGH-to-LOW. See Note.	-	25	-	mV
Schmitt trigger input voltage	V_{sh}		1	-	$V_{cc} - 1$	V
Discriminator levels	N		-	1042	-	levels
Discriminator LOW-level voltage	V_{DL}	$I_D = -0.5 \text{ mA}$	-	-	0.3	V
Discriminator HIGH-level voltage	V_{DH}	$I_D = 0.5 \text{ mA}$	$V_{cc} - 0.4$	-	-	V
Discriminator leakage current	I_{D1}		-	-	± 1	μA
Discriminator operating frequency	f_D	See Note.	-	-	1	MHz
Oscillator frequency	f_{osc}	See Note.	-	-	1	MHz
Index detector Hall-effect transducer amplifier phase input voltage	V_{ID}		1.5	-	$V_{cc} - 0.5$	V
Index detector Hall-effect transducer amplifier input bias current	I_{IDB}		-	-	± 10	μA
Induction current for hysteresis	I_{IDO}		5	10	15	μA
Index detector LOW-level output voltage	V_{IDL}	$V_{ID} = 5 \text{ V}$	-	-	0.4	V
Index detector HIGH-level output voltage	V_{IDH}	$V_{ID} = 5 \text{ V}$	4.5	-	-	V

LB1813M

Parameter	Symbol	Conditions	Ratings			Unit
			min	typ	max	
Index delay circuit discharge voltage	V _{DLDC}	V _{ID} = 5 V	-	2.5	-	V
Index delay circuit LOW-level output voltage	V _{DLL}	V _{ID} = 5 V	-	-	0.4	V
Index delay circuit HIGH-level output voltage	V _{DLH}	V _{ID} = 5 V	4.5	-	-	V
Thermal shutdown temperature	TSD	See note.	150	180	-	°C
Thermal shutdown temperature hysteresis	ΔTSD	See note.	-	40	-	°C

Note

These values are calculated ratings only and are not measured.

Typical Performance Characteristics

Power dissipation vs. ambient temperature

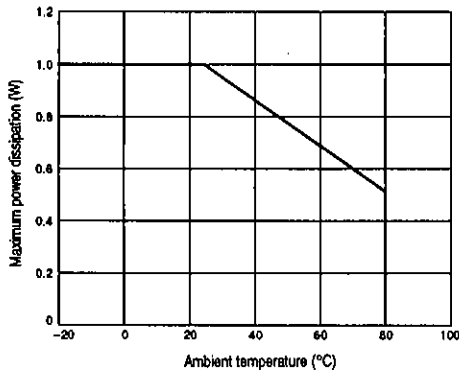

Functional Description

Digital Speed Control

The motor speed is given by the equation

$$f_{PG} = \frac{f_{osc} \times D}{1024}$$

where f_{PG} is the revolution detector frequency, f_{osc} is the crystal oscillator frequency and D is the frequency-divider constant. When SL1 is HIGH, D is 5/8, and when LOW, D is 6/8.

$f_{osc} = 1$ MHz, $FG = 60$ pulses/revolution

SL1/SL2	H	L
H	600 rpm	300 rpm
L	720 rpm	360 rpm

When SL1 is HIGH,

$$T_{300} \approx 0.693C \times R_6$$

$$t_{300} \approx \frac{C \times R_6 \times R_7}{R_6 + R_7} \left[0.405 + \ln \left(\frac{0.781R_6 - R_7}{R_6 - 2R_7} \right) \right]$$

When SL1 is LOW,

$$T_{360} \approx 0.577C \times R_6$$

$$t_{360} \approx \frac{C \times R_6 \times R_7}{R_6 + R_7} \left[0.522 + \ln \left(\frac{0.781R_6 - R_7}{R_6 - 2R_7} \right) \right]$$

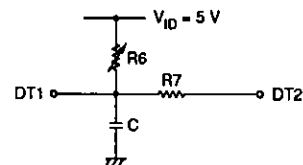

If the index pulse output only is to be used, DT1 and DT2 should be short circuited.

Output Phase Control

The motor driver output source and sink phases are selected by the voltages on the Hall-effect transducer amplifier inputs for each phase as shown in Table 1. Note that a Hall-effect transducer amplifier input is HIGH when the voltage on the positive input exceeds the voltage on the negative input.

Table 1. Source and sink phase selection

Source phase	Sink phase	Hall-effect transducer amplifier inputs		
		U	V	W
V	W	HIGH	HIGH	LOW
V	U	LOW	HIGH	LOW

Table 1. Source and sink phase selection—continued

Source phase	Sink phase	Hall-effect transducer amplifier inputs		
		U	V	W
W	U	LOW	HIGH	HIGH
W	V	LOW	LOW	HIGH
U	V	HIGH	LOW	HIGH
U	W	HIGH	LOW	LOW

Index Detector Timing

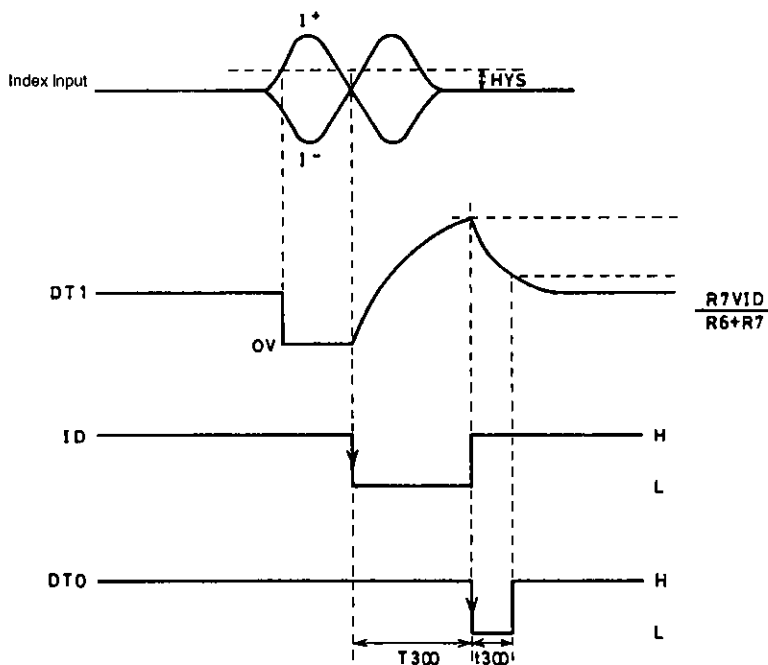

- No products described or contained herein are intended for use in surgical implants, life-support systems, aerospace equipment, nuclear power control systems, vehicles, disaster/crime-prevention equipment and the like, the failure of which may directly or indirectly cause injury, death or property loss.
- Anyone purchasing any products described or contained herein for an above-mentioned use shall:
 - ① Accept full responsibility and indemnify and defend SANYO ELECTRIC CO., LTD., its affiliates, subsidiaries and distributors and all their officers and employees, jointly and severally, against any and all claims and litigation and all damages, cost and expenses associated with such use:
 - ② Not impose any responsibility for any fault or negligence which may be cited in any such claim or litigation on SANYO ELECTRIC CO., LTD., its affiliates, subsidiaries and distributors or any of their officers and employees, jointly or severally.
- Information (including circuit diagrams and circuit parameters) herein is for example only; it is not guaranteed for volume production. SANYO believes information herein is accurate and reliable, but no guarantees are made or implied regarding its use or any infringements of intellectual property rights or other rights of third parties.

This catalog provides information as of May, 1995. Specifications and information herein are subject to change without notice.