

**LB1868****Two-Phase Brushless Fan Motor Driver****Preliminary Overview**

The LB1868 is a 2-phase unipolar brushless motor driver. With only a few peripheral parts, lockup protection and automatic recovery can be implemented. The IC can be configured for 12V or 24V operation and a wide range of variations, from LOW speed to H-High speed and from 60 cm to 120 cm square using the same PCB. This makes it easy to design highly reliable fan motor installations.

**Functions and Features**

- Output protection Zener diode with variable withstand voltage  
Z1, Z2 pins open: VOLM = 57V (24V specification)  
Z1, Z2 pins shorted: VOLM = 32V (12V specification)  
External Zener diode connected across Z1 - VCC pins: support for fans with large drive current
- External resistor allows configuration for 12V or 24V.
- Direct Hall element connection possible (built-in Hall amplifier with hysteresis supports core without auxiliary electrode)
- Built-in output transistor with 1.0A output current (strengthened negative-current support for core without auxiliary electrode)
- Built-in rotation detection function: Low during rotation and High during stop
- Built-in lockup protection with automatic recovery
- Built-in thermal shutdown

**Package Dimensions**

unit: mm

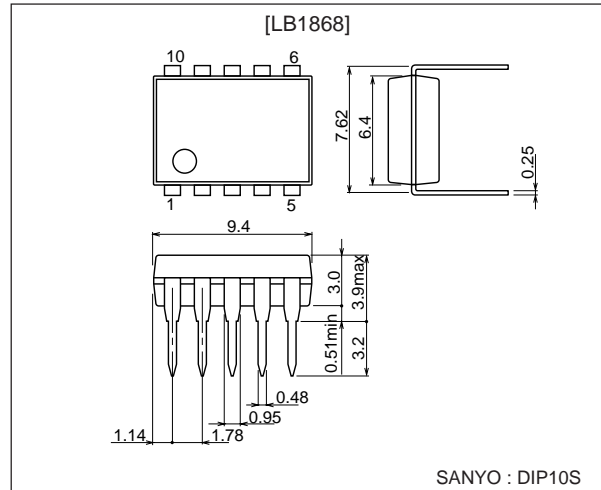
**3098B-DIP10S**

- Any and all SANYO products described or contained herein do not have specifications that can handle applications that require extremely high levels of reliability, such as life-support systems, aircraft's control systems, or other applications whose failure can be reasonably expected to result in serious physical and/or material damage. Consult with your SANYO representative nearest you before using any SANYO products described or contained herein in such applications.
- SANYO assumes no responsibility for equipment failures that result from using products at values that exceed, even momentarily, rated values (such as maximum ratings, operating condition ranges, or other parameters) listed in products specifications of any and all SANYO products described or contained herein.

## Specifications

### Absolute Maximum Ratings at Ta = 25°C

Parameter	Symbol	Conditions	Ratings	Unit
Maximum input current	ICC max	t ≤ 20 ms	200	mA
Maximum applied output voltage	VOUT max		Internal	V
Maximum output current	IOUT max		1.0	A
Current flowing into RD pin	IRD max		10	mA
RD applied voltage	VRD max		30	V
Allowable power dissipation	Pd max		1.1	W
Operating temperature	Topr		-30 to +80	°C
Storage temperature	Tstg		-55 to +150	°C

### Allowable Operating Ranges at Ta = 25°C

Parameter	Symbol	Conditions	Ratings	Unit
Input voltage range	ICC		6.0 to 50	mA
Common mode input voltage range	VICM		0.2 to VIN-1.5	V

### Electrical Characteristics at Ta = 25°C, Icc = 10 mA

Parameter	Symbol	Conditions	Ratings			Unit
			min	typ	max	
Output limiter withstand voltage	VOLM1	Z1, Z2 open	54	57	60	V
	VOLM2	Z1, Z2 short	31	33	35	V
Output saturation voltage	Vosat 1 2	Io = 0.5A		0.95	1.2	V
		Io = 1.0A		0.15	1.5	V
VIN voltage	VIN	ICC = 7.0 mA	6.4	6.7	7.0	V
Hall input sensitivity (at zero peak)	VHN	Including offset and hysteresis			20	mV
RD output saturation voltage	VRDsatsat	IRD = 5 mA		0.1	0.3	V
CT drain current	IC1	C = GND	2.7	3.8	4.9	μA
CT discharge current	IC2	C = VIN	0.19	0.30	0.41	μA
Comp input threshold voltage	VTH1		0.77	0.8VIN	0.83	V
	VTH2		0.42	0.45VIN	0.48	V
Thermal protection operating temperature	TSD	Design target value*		180		°C
Thermal protection circuit hysteresis	ΔTSD	Design target value*		40		°C

\* Design target values are not measured.

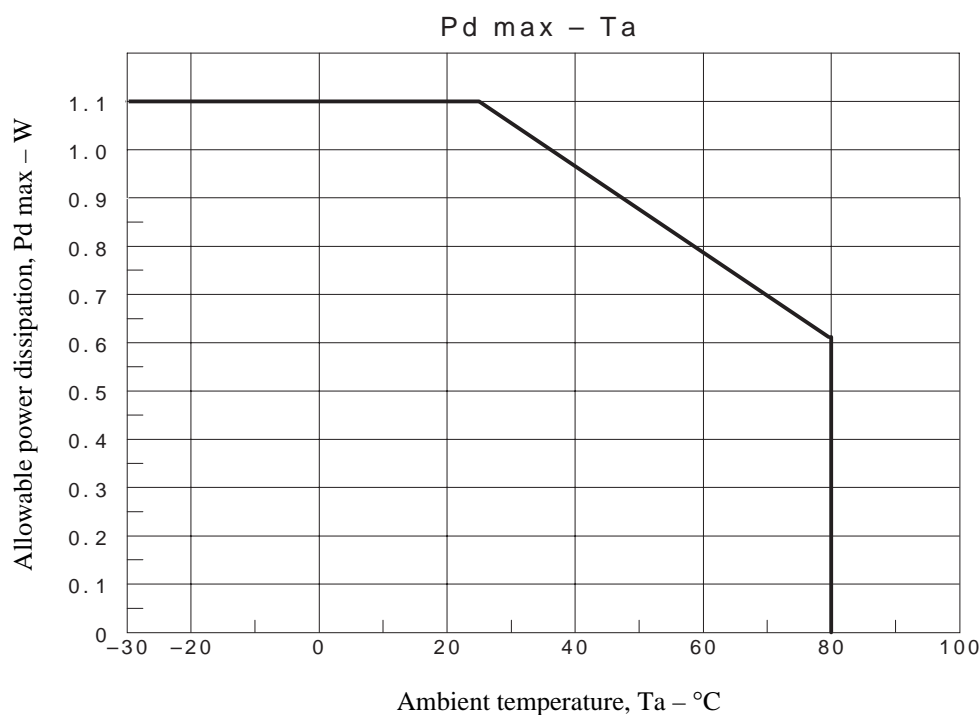

Block Diagram and Sample Application Circuit

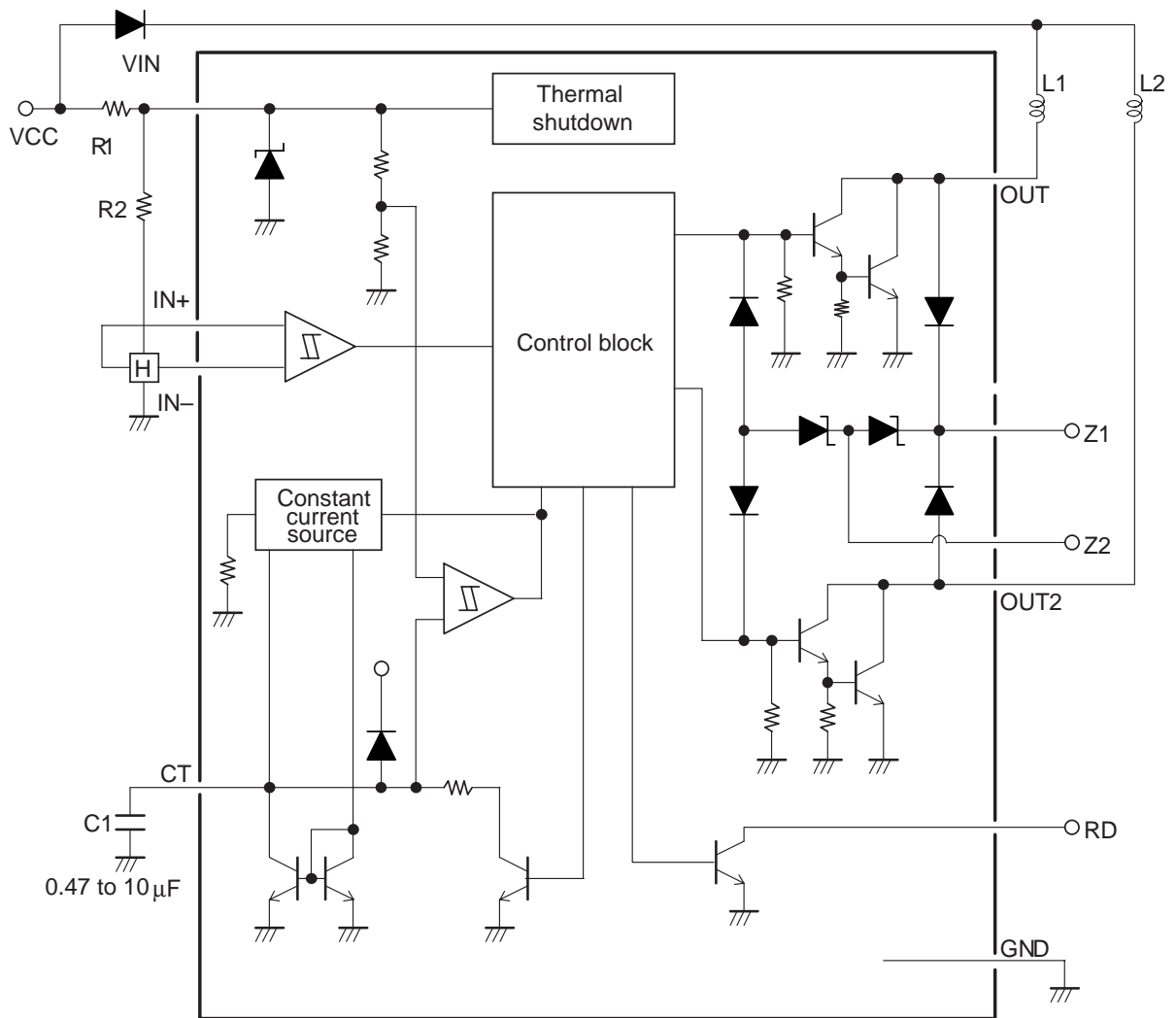

Truth Table

IN+	IN-	C	OUT1	OUT2	RD
H	L	L	H	L	L
L	H	L	L	H	L
H	L	H	H	H	H
L	H	H	H	H	H

\*RD is a latch type output.

**Pin Description**

Pin name	Function
IN-	Hall input + pin Hysteresis amplifier
IN+	Hall input – pin Hysteresis amplifier
CT	Lockup protection time setting capacitor pin (0.47 to 4.7 μF)
Z1	External Zener diode pin (external Zener diode to be connected between power supply and Z1)
Z2	Kickback absorption voltage alteration pin (shorted to Z1: 12V operation)
OUT1	Output 1 pin
OUT2	Output 2 pin
VIN	Regulated power supply input pin (limiting resistor to be inserted between power supply and VIN)
GND	GND pin
RD	Lockup detection pin (latch type)

**Pin Assignment**

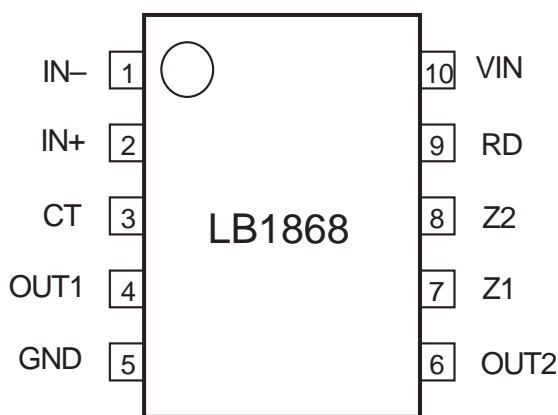

Top view

- Specifications of any and all SANYO products described or contained herein stipulate the performance, characteristics, and functions of the described products in the independent state, and are not guarantees of the performance, characteristics, and functions of the described products as mounted in the customer's products or equipment. To verify symptoms and states that cannot be evaluated in an independent device, the customer should always evaluate and test devices mounted in the customer's products or equipment.
- SANYO Electric Co., Ltd. strives to supply high-quality high-reliability products. However, any and all semiconductor products fail with some probability. It is possible that these probabilistic failures could give rise to accidents or events that could endanger human lives, that could give rise to smoke or fire, or that could cause damage to other property. When designing equipment, adopt safety measures so that these kinds of accidents or events cannot occur. Such measures include but are not limited to protective circuits and error prevention circuits for safe design, redundant design, and structural design.
- In the event that any or all SANYO products(including technical data, services) described or contained herein are controlled under any of applicable local export control laws and regulations, such products must not be exported without obtaining the export license from the authorities concerned in accordance with the above law.
- No part of this publication may be reproduced or transmitted in any form or by any means, electronic or mechanical, including photocopying and recording, or any information storage or retrieval system, or otherwise, without the prior written permission of SANYO Electric Co., Ltd.
- Any and all information described or contained herein are subject to change without notice due to product/technology improvement, etc. When designing equipment, refer to the "Delivery Specification" for the SANYO product that you intend to use.
- Information (including circuit diagrams and circuit parameters) herein is for example only ; it is not guaranteed for volume production. SANYO believes information herein is accurate and reliable, but no guarantees are made or implied regarding its use or any infringements of intellectual property rights or other rights of third parties.

This catalog provides information as of August, 2000. Specifications and information herein are subject to change without notice.