



LB5918A Data Sheet

Key PowerSensor+™ Specifications

- High Accuracy
- Frequency Range: 1 MHz to 18 GHz
- Dynamic Range: -60 dBm to +20 dBm
- 1.95% Total RSS error*
- 1.20:1 VSWR

*With a well matched DUT @ -20 dBm & 1 GHz



Key Features

- Diameter 1.6" length 3.0" (plus connector)
- Standard connector high quality 2.92mm male
- Includes full featured software application
- Support for Windows, LINUX, & embedded systems
- Interfaces: USBTMC, USBHID, SPI & I2C
- Industry Compatible IEEE 488.2 SCPI Command Set
- Measurement storage depth – internal memory
 - 67 million measurements non-volatile memory
 - 31 million samples high speed trace ram
- Up to 500 un-buffered measurement per second
- User settable real-time clock with internal backup
- Includes Test Harness for ATE development
- Includes robust driver support and example code



LB5918A can be ordered with options including the LB956A ATE Mounting Bracket, Option A05 Secure USB cable, Option SPI (SPI & I2C Interface with Cable). Consult the LB5900 series sensor ordering guide.

General Description

The LB5918A is a high accuracy, easy to use RF & Microwave Power Sensor for general purpose average power, True RMS and scalar measurements. The sensors feature exceptionally fast measurement speed, a broad dynamic range, and the widest set of options for programmatic and embedded applications in the industry. LadyBug's feature rich Power Meter Application is provided with each sensor. The sensor is useful for research & development, manufacturing & service applications including radar, satellite, telecommunications, 802.11... testing, etc.

USB HID and USBTMC interfaces offer platform independent connectivity to most computers. Optional SPI & I2C interfaces can be used for embedded applications. Optional unattended operation can be set up and data collected through the sensors USB or SPI/I2C ports. Once measurements are set up, a computer or power meter is not required to operate the sensor making it ideal for unattended applications.

LadyBug's NoZero NoCal feature eliminates the need for zeroing and calibration prior to making measurements, simply connect and measure.

Features, Options & Applications

- Includes full featured software
- Very Strong ATE Support
- Competitive instrument compatibility
- VISA IO library compatible
- Three flexible interfaces
- Optional SPI & I2C capability w/ connector
- Internal & External Triggering
- Optional Recorder Output

- Optional Unattended operation capability
- User Zero and Calibration are not required
- Fully calibrated over temperature
- Very good frequency flatness
- Average power on any modulation format
- Rugged USB connector
- Sturdy aluminum housing
- Optional secure USB connector

Precision Power Meter software application for use with any LB5900 Series Sensor. Includes Sensor Window, Measurement Calculation Window, Tabular Logging, Analog Gauge and Strip Chart. All features are included and the unrestricted application can be used as many computers as required without additional charge.

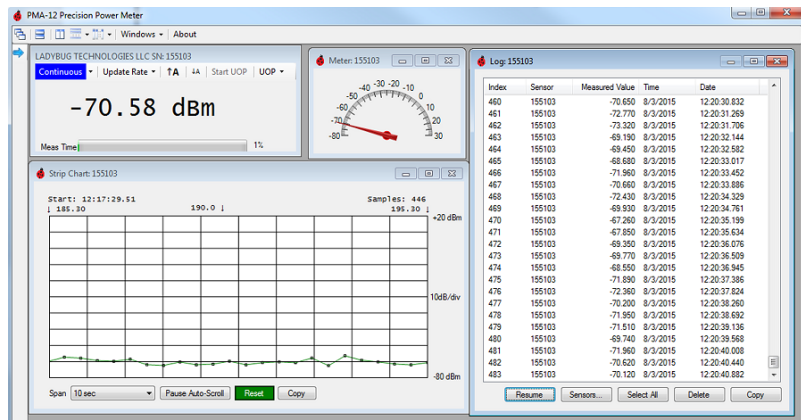

Parameter	Specification	
Connector	Type N Male	
Frequency Range	1 MHz to 18 GHz	
Dynamic Range (Calibrated Measurement Range)	-60 dBm to +20 dBm	
Maximum Power Level		
Continuous average power	+20 dBm (100 mW)	Damage Level: +27dBm (500 mW)
Peak pulse power for 10 us maximum pulse width	+27 dBm (0.5 W)	Damage Level: +30dBm (1 W)
Maximum DC input voltage	16 VDC (On the RF Input)	
Recommended Calibration Cycle	1 year	
Accuracy (Note 1)	Total RSS Error = $\sqrt{(Mm^2+CF^2+L^2+N^2+T^2+Z^2)}$	
	Specification	
Match (Type N)		
1 MHz to 4 GHz	1.12 VSWR	
4 GHz to 10 GHz	1.23 VSWR	
10 GHz to 18 GHz	1.30 VSWR	
Calibration Factor (Type N)		
1 MHz to 4 GHz	1.8%	
4 GHz to 10 GHz	1.7%	
10 GHz to 18 GHz	1.9%	
Linearity (Note 3)		
+15 dBm to +20 dBm	3.0%	
-15 dBm to +15 dBm	2.5%	
-60 dBm to -15 dBm	2.0%	
Noise (5 Second integration)		
-30 to +20 dBm	0.10%	
-40 to -30 dBm	0.25%	
-50 to -40 dBm	0.50%	
-60 to -50 dBm	1.00%	
Temperature (°C)		
40-50	2.00%	
30-40	.75%	
20-30	0.00%	
10-20	0.75%	
0-10	2.00%	
Zero Offset (Note 2 & 3)	$\{[(1.0nW @ 25^{\circ}C) + \Delta T \times (0.075nW/^{\circ}C)] \pm 0.01nW /month\}$	

Notes: 1 Error term definitions: Mm (Mismatch); CF (Cal Factor); N (Noise); L (Linearity); T (Temperature); Z (Zero Offset). All error terms are converted to percentages for RSS calculation. 2 Use the following formula to determine Zero Offset error (%): Z = (Zero Offset Power / Measured Power)*100. 3 Linearity and Zero Offset are measured as a combined specification as LadyBug sensors require no meter zeroing or reference calibration before use.

LadyBug’s patented multidimensional calibration process eliminates the need to zero or calibrate its sensor prior to or during use. The chart below shows typical power measurement stability over a sensors operating temperature range.

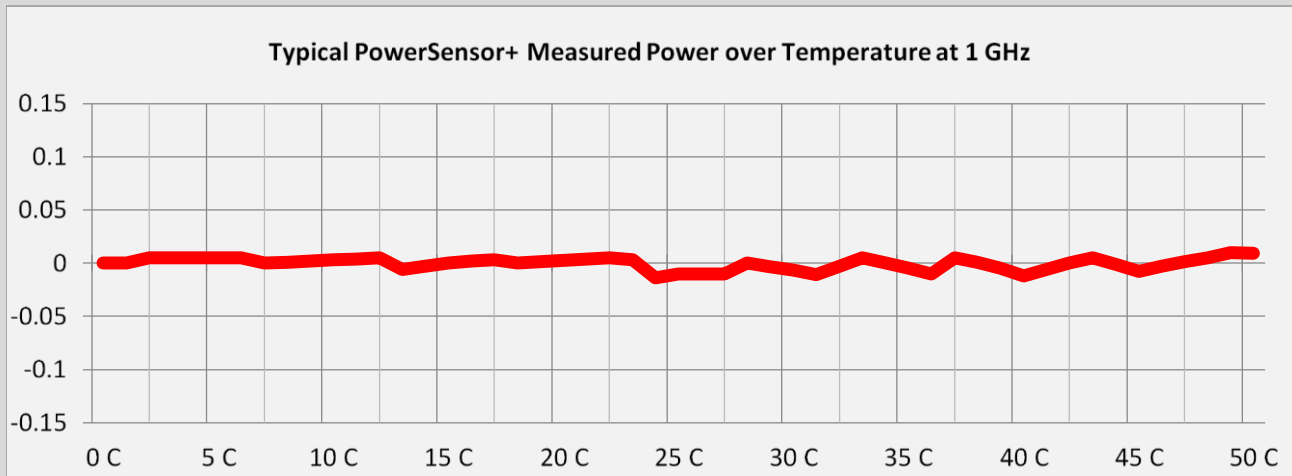

Interface Connectivity

LB59XXX products support both USBTMC and USB HID. Direct control of the sensor is also possible using optional SPI and I2C interface ports. These connectivity functions are optimized for programmatic control as well as unattended and logged power measurements. The sensors can be setup, controlled and data taken from any of the connectivity options. LadyBug sensors are provided with a full featured application that utilizes the sensors USB interfaces. Refer to the Option SPI documentation for information regarding I2C and SPI interfaces.

USBTMC	USB488 compliant
USB HID	USB Human Interface Device Class compliant
SPI / I2C (Option SPI)	Cable and connector are included with option SPI. Cable may also be used to power the sensor for unattended applications.

Remote Programming

The sensor is designed for full programmatic control in ATE systems or other applications requiring remote programming. Supporting documentation and guides are available from LadyBug. LB59XXX sensors use SCPI (Standard Commands for Programmable Instruments) commands. This test instrument standard is common to most test equipment designed for programmatic remote control. Commands are textual and intuitive. All three sensor connectivity options use the SCPI command set. LadyBug’s SICL test harness can be utilized for testing and developing automated test systems. Refer to the appropriate programming guide for additional information on remote programming.

Supporting Ports	USBTMC, USB HID, SPI/I2C
Command Set	SCPI (Standard Commands for Programmable Instruments)
Compatibility	Compatible with systems using USBTMC programmatic control, NI™ & Agilent™ Visa IO libraries, Agilent™ U2000 & others using SCPI command set.*

* Agilent is a trademark of Agilent Technologies Inc; NI is a trademark of National Instruments, Inc.

Recorder Output

Option 001, includes Recorder Out and Wideband Video Out on LB5900 series sensors. This option gives the analog output user a variety of output options from accurate scaled measurements to fast un-calibrated video information.

Recorder Output is a filtered analog output that can be used for various purposes. The output provides an accurate scaled voltage representing power level of the signal. The output can be set as linear or log and can be scaled to suit specific purposes. When enabled, Recorder Out uses the same SMB port used by Trigger Out making the port unavailable for triggering use. Trigger in is not affected.

Bandwidth	30 Hz
Output range	0 to 1 Volt into 1,000 Ohms. Note: Potential of 2.5 Volts when set as Recorder Out; or 5 Volts when used as Trigger Output
Output impedance	1,000K Ohms
Resolution	+/- 25 μ v
DC Offset	0 to 5 mv
Scale	Linear
Connector	SMB Male (shared with Trigger Out and Wideband Video Out)

Triggering

LB5900 Series Sensors' Trigger functions including slope, level, trigger delay, hold off and rearm delay can be set. External Trigger Input and are available for gated measurements, synchronizing multiple sensors, or other purposes. Trigger Input and output use SMB Male connectors, these may be shared with other options.

Modes	Continuous, Single
Trigger source	Internal or signal level, Immediate, External.
Trigger resolution	1 us
Internal level	Settable to approximately -50dBm to 20dBm. Slope negative or positive.
Ext Trigger input levels	Min high level 2.0 Volts, Max low level 0.8 Volts.
External input load	Selectable 100 k Ω or 50 Ω
Output level	Maximum \approx VUSB \approx 5.5VDC (typical). Typical high level 4.0V with 600 ohm load (With VUSB=5.0V). Max low level 0.8 V. Minimum load resistance 200 ohms.
Absolute input level limits	+5.5 Volts maximum; -0.5 Volts minimum
Trigger Out Pulse width	500ns

Military option (MIL)

The military option is designed to address security and data sanitization issues. When purchased with this option, the user cannot write to any non-volatile memory. Consult the factory for information regarding option MIL.

Real time clock

LB5900 Series Sensors contains a real time clock that can be used to time stamp logged measurements. When the sensor is powered on, the sensors high accuracy time base is used to increase the accuracy of the real time clock.

Time accuracy	Typical: Un-powered 100 ppm at 35 degrees Celsius; Stable & under power 2 ppm (disciplined by high accuracy time-base). Consult the factory for further information. Aging 2ppm +/- 1ppm / Year
Functionality	Provides time stamp data for measurements stored in memory. When used with Option UOC (unattended operation), can deactivate low power mode, trigger measurements and activate low power mode
Backup	Super cap. When fully charged, provides 1 day (typical) RTC operation with no power applied to the sensor. Minimum charge time 5 minutes.

Memory & Logging

The LB5918A contains substantial volatile and non-volatile memory. The sensors larger non-volatile flash memory is designed for long term logging and unattended operation applications.

Note: If option MIL (security & sanitization) is ordered, non-volatile flash memory is not accessible and/or may not be installed in the sensor.

Parameter	Specification
Non-volatile NAND flash	4 Gigabits configurable by user to optimize measurement strategy
Storage rate	500 measurements per second
Measurement data points	67 Million (Basic UOP mode).

Unattended Operation (UOP)

Unattended operation is used to make autonomous measurements. Once setup using a computer, the sensor only requires power to function. Measurements are stored in the sensors non-volatile memory and are time stamped using the sensor's internal real time clock. The option allows the use of trigger functions and/or time controlled intervals. Recorder output can be enabled while in unattended operation allowing calibrated analog output functions with no computer or power meter connection. Power can be applied using a USB power only cable or if Option SPI has been purchased, its ribbon cable can be used to apply power.

Uncertainty Calculation Work Sheet

Use this sheet to calculate uncertainty for a specific set of conditions using the root sum of squares method. Following the work sheet is a completed example.

Conditions

Operating Frequency (GHz)	
Power Level (dBm)	
DUT Match (VSWR)	
Temperature (°C)	

Sensor characteristics at conditions

Cal Factor (% & Actual)		
Linearity (% & Actual)		
Noise (% & Actual)		
Uncertainty Due To Temperature (% & Actual)		
Match (VSWR)		
Zero Offset		

1. Calculate Sensor reflection coefficient, ρ from Sensor VSWR

$$\rho_{\text{sens}} = (\text{VSWR}-1)/(\text{VSWR}+1)$$

$$\rho_{\text{sens}} =$$

1. Calculate DUT reflection coefficient, ρ from DUT VSWR

$$\rho_{\text{DUT}} = (\text{VSWR}-1)/(\text{VSWR}+1)$$

$$\rho_{\text{DUT}} =$$

Note: Reflection coefficient can be calculated from return loss using the formula $\rho=10^{(-\text{RL}/20)}$

2. Calculate total match uncertainty

$$Mm = (1+(\rho_{\text{sens}} * \rho_{\text{DUT}}))^2-1$$

$$Mm =$$

3. Calculate Zero Offset uncertainty (See Specification and notations)

- a. Convert power from dBm to Linear

$$\text{Linear Power} = 10^{(\text{PowdBm}/10)}$$

$$\text{Linear Power} =$$

- b. Calculate Zero Offset

$$\text{Zero Offset} = (\text{Zero Offset Specification}/\text{Linear Power})$$

$$\text{Zero Offset} =$$

4. Calculate Total RSS uncertainty

$$\text{Uncertainty (\%)} = \sqrt{(\text{Mm}^2 + \text{CF}^2 + \text{L}^2 + \text{N}^2 + \text{T}^2 + \text{Z}^2)} * 100$$

$$\text{Uncertainty (\%)} =$$

Uncertainty Calculation Work Sheet Example

This sheet was completed using typical sensor data.

Conditions

Operating Frequency (GHz)	10
Power Level (dBm)	-20
DUT Match (VSWR)	1.19
Temperature (°C)	25

Sensor characteristics at conditions

Cal Factor (% & Actual)	1.35%	0.0135
Linearity (% & Actual)	0.22%	0.0022
Noise (% & Actual)	0.10%	0.0010
Uncertainty Due To Temperature (% & Actual)	0%	0.0
Match (VSWR)		1.2:1
Zero Offset		3.5E-10

Calculate Sensor reflection coefficient, ρ from Sensor VSWR

$$\rho_{\text{sens}} = (\text{VSWR}-1)/(\text{VSWR}+1)$$

$$\rho_{\text{sens}} = (1.2-1)/(1.2+1) = .091$$

2. Calculate DUT reflection coefficient, ρ from DUT VSWR

$$\rho_{\text{DUT}} = (\text{VSWR}-1)/(\text{VSWR}+1)$$

$$\rho_{\text{DUT}} = (1.19-1)/(1.19+1) = 0.087$$

Note: Reflection coefficient can be calculated from return loss using the formula $\rho=10^{(-\text{RL}/20)}$

3. Calculate total match uncertainty

$$\text{Mm} = (1+(\rho_{\text{sens}} * \rho_{\text{DUT}}))^2-1$$

$$\text{Mm} = (1+(.091*.087))^2-1 = 0.0159$$

4. Calculate Zero Offset uncertainty (See Specification and notations)

- a. Convert power from dBm to Linear

$$\text{Linear Power} = 10^{(\text{PowdBm}/10)}$$

$$\text{Linear Power} = 10^{(-20/10)} = .01\text{mw}$$

- b. Calculate Zero Offset

$$\text{Zero Offset} = (\text{Zero Offset Specification}/\text{Linear Power})$$

$$\text{Zero Offset} = (0.35\text{nw} / .01\text{mw}) = .000035$$

5. Calculate Total RSS uncertainty

6. Uncertainty (%) = $\sqrt{(\text{Mm}^2+\text{CF}^2+\text{L}^2+\text{N}^2+\text{T}^2+\text{Z}^2)} * 100$

$$\text{Uncertainty (\%)} = \sqrt{(.0159^2+0.0135^2+.0022^2+.0010^2 +0.0^2+.000035^2)} = .021 = 2.1\%$$

LB59XXX Outline drawings

Dimension tolerance +/- 0.063"

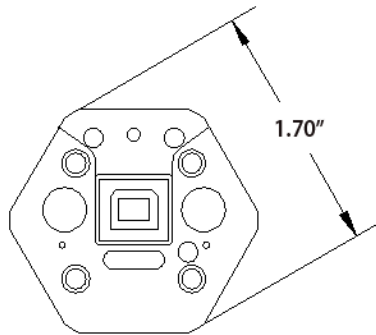

Rear (USB) View

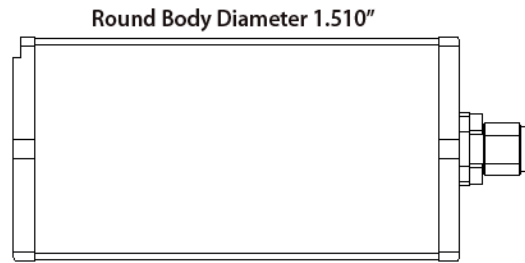

Side View

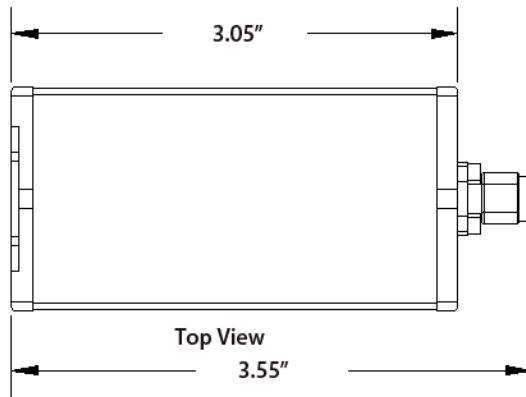

Top View

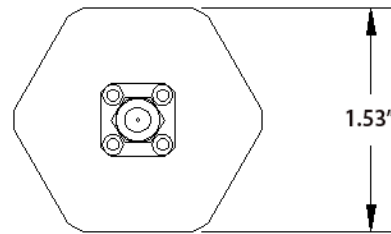

Front View

SMA & 3.5mm Connectors

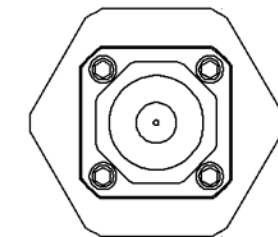
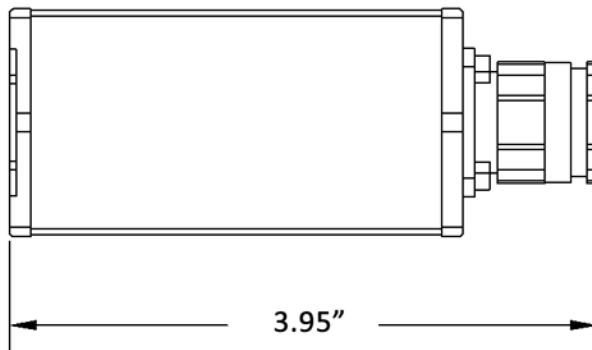

Type-N Male Connector