

## **WiFi Module Data Sheet**

**Broadcom BCM43362 WiFi + ST Micro STM32F405 MCU**

**Tentative P/N : LBWA1ZV1CD-716**

## The revision history of the product specification

Issued Date	Revision Code	Revision Page	Changed Items	Change Reason
Apr.11.2014			First issued	

## TABLE OF CONTENTS

1. Scope.....	3
2. Part Number .....	3
3. Block Diagram .....	4
4. Dimensions, Marking and Terminal Configurations .....	5
4.1. Dimensions .....	5
4.2. Terminal Configurations .....	6
4.3. Pin Mux Table .....	8
5. LED Drive .....	9
6. Phototransistor .....	9
7. Absolute Maximum Rating.....	10
8. Operating Condition .....	10
9. Electric characteristics .....	10
10. Power Up Sequence .....	11
10.1. Without NRST control .....	11
10.2. With NRST control.....	11
10.2.1. NRST Circuit .....	11
11. RF Characteristics .....	12
11.1. RF Characteristics for IEEE802.11b (11Mbps mode unless otherwise specified.) .....	12
11.2. RF Characteristics for IEEE802.11g (54Mbps mode unless otherwise specified.) .....	12
11.3. RF Characteristics for IEEE802.11n (65Mbps(MCS7) mode unless otherwise specified.) ...	13
12. Land Pattern (Top View) .....	14
13. Reference Circuit .....	15
13.1. Low Cost Schematic.....	15
13.2. Low Power Schematic .....	16
14. Recommended Components .....	17
14.1. Bi-color LED .....	17
14.2. Phototransistor.....	17
14.3. Low Cost Schematic.....	17
14.4. Low Power Schematic .....	17
15. Tape and Reel Packing .....	18
16. NOTICE .....	21
16.1. Storage Conditions:.....	21
16.2. Handling Conditions:.....	21
16.3. Standard PCB Design (Land Pattern and Dimensions): .....	21
16.4. Notice for Chip Placer:.....	21
16.5. Soldering Conditions:.....	22
16.6. Cleaning:.....	22
16.7. Operational Environment Conditions:.....	22
16.8. Input Power Capacity: .....	22
17. PRECONDITION TO USE OUR PRODUCTS .....	23

Please be aware that an important notice concerning availability, standard warranty and use in critical applications of Murata products and disclaimers thereto appears at the end of this specification sheet.

## 1. Scope

This specification is for the LBWA1ZV1CD smart module that provides connectivity to the internet via WiFi with embedded OS that works with the Electric Imp cloud service.

- 802.11 b/g/n WiFi
  - 20MHz 11n channels, 1 x 1
- 32-bit Cortex M4 processor
  - Robust embedded operating system with fail-safe firmware updates
  - Virtual machine for vendor firmware
- LED drive for red/green status LEDs
- Phototransistor input for Electric imp's patent-pending BlinkUp™ technology to provide optical configuration
- 23 user selectable I/Os
  - GPIO, PWM, Analog input & output, SPI, UART, I2C
  - Dedicated SPI bus for local storage
- Low power 4uA sleep mode (with external load switch)
  - Option for coin cell RTC battery backup
- Compliant with the RoHS directive

## 2. Part Number

Sample Part Number
LBWA1ZV1CD-716

### 3. Block Diagram

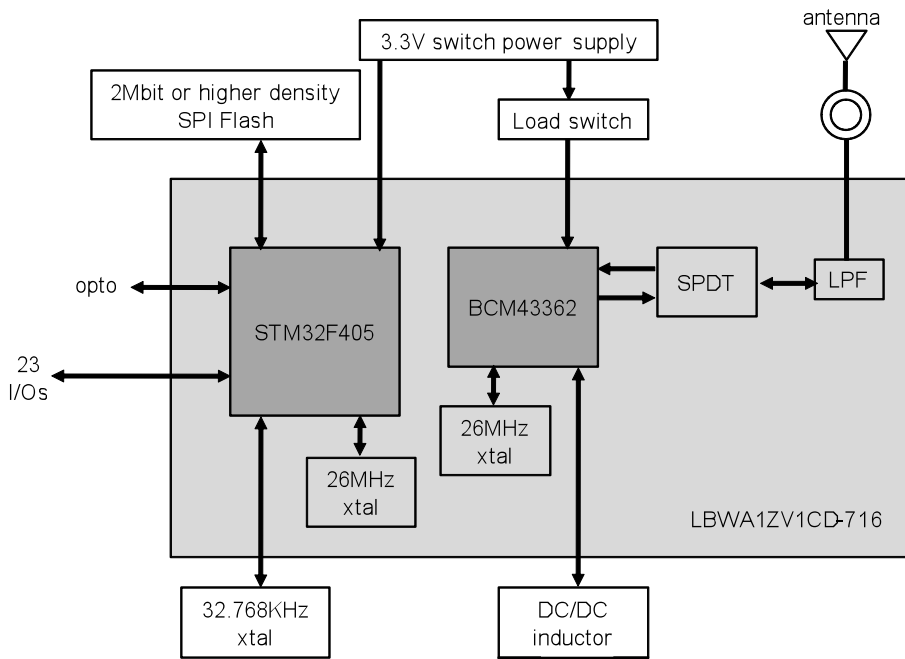

<Low Power Block Diagram>

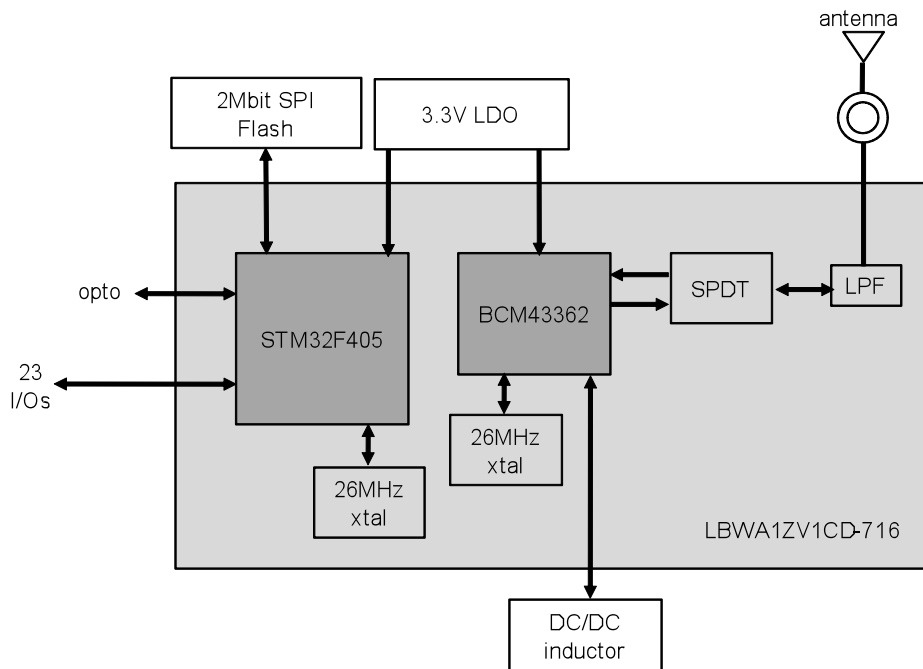

<Low Cost Block Diagram>

## 4. Dimensions, Marking and Terminal Configurations

### 4.1. Dimensions

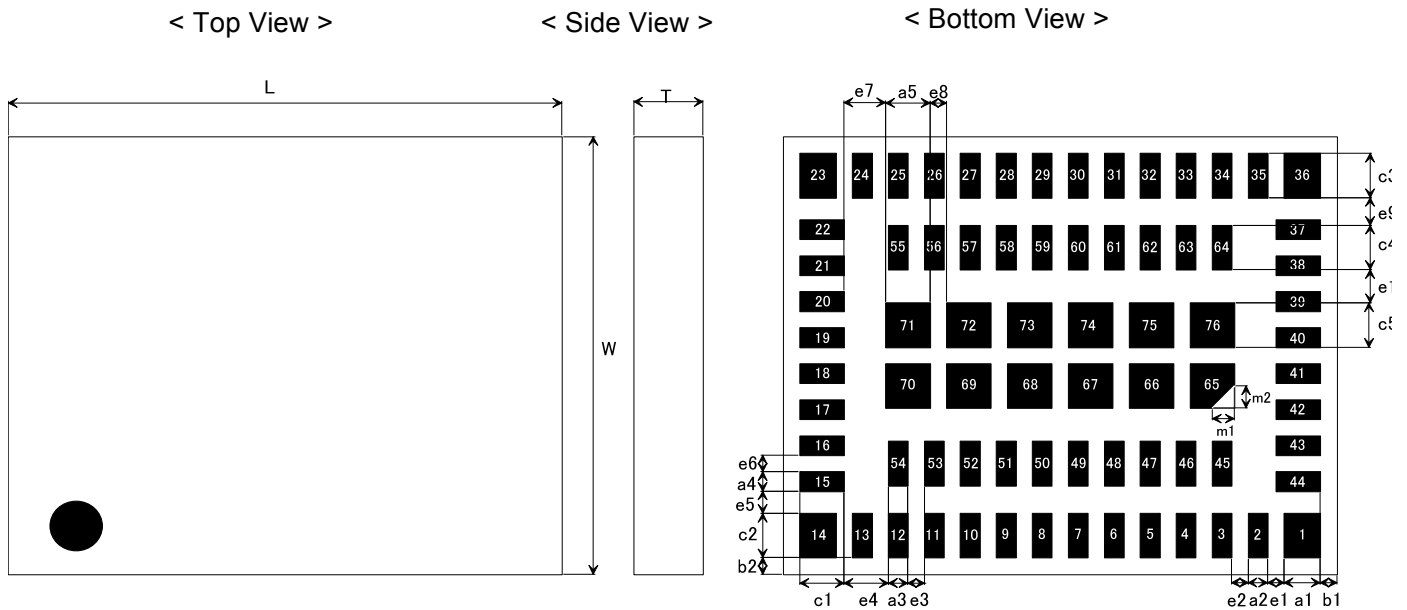

Mark	Dimensions	Mark	Dimensions	Mark	Dimensions
L	10.0 +/- 0.2	W	7.9 +/- 0.2	T	1.25 max.
a1	0.65 +/- 0.1	a2	0.35 +/- 0.1	a3	0.35 +/- 0.1
a4	0.35 +/- 0.1	a5	0.80 +/- 0.1	b1	0.30 +/- 0.2
b2	0.30 +/- 0.2	c1	0.80 +/- 0.1	c2	0.80 +/- 0.1
c3	0.80 +/- 0.1	c4	0.80 +/- 0.1	c5	0.80 +/- 0.1
e1	0.30 +/- 0.1	e2	0.30 +/- 0.1	e3	0.30 +/- 0.1
e4	0.80 +/- 0.1	e5	0.40 +/- 0.1	e6	0.30 +/- 0.1
e7	0.75 +/- 0.1	e8	0.30 +/- 0.1	e9	0.50 +/- 0.1
e10	0.60 +/- 0.1	m1	0.40 +/- 0.1	m2	0.40 +/- 0.1

(unit : mm)

## 4.2. Terminal Configurations

No.	Terminal Name	Type	Description
1	GND	-	Ground
2	OPTO_Bias	O	Phototransistor bias voltage
3	OPTO_IN	I	Phototransistor input
4	PinW	I/O	I/O, please refer to Pin mux table
5	OSC32_IN	I	MCU sleep clock input
6	OSC32_OUT	O	MCU sleep clock output
7	PinN	I/O	I/O, please refer to Pin mux table
8	PSU_EN	O	External power supply enable
9	WLAN_POWER_EN	O	External power gate enable
10	GND	-	Ground
11	GND	-	Ground
12	ANT	-	Antenna
13	GND	-	Ground
14	GND	-	Ground
15	VDD	PI	Power supply for MCU VDD and WLAN Digital IO
16	WLAN_ANT_CTL2	O	Antenna switch control. Default is low. NC if not in use.
17	WLAN_ANT_CTL1	O	Antenna switch control. Default is high. NC if not in use.
18	VDD_PA	PI	Power supply for Internal Power Amplifier.
19	VDD_PA	PI	
20	VDD_WLAN	PI	Power supply for WLAN IC
21	VDD_WLAN	PI	
22	VDD_DCDC_IN	PI	Voltage input for core LDO, low noise LDO1 and VCO/LDO
23	GND	-	Ground
24	VDD_DCDC_OUT	PO	Voltage output for core LDO.
25	SPIFLASH_NCS	O	SPI flash nCS
26	SPIFLASH_MISO	I	SPI flash MISO

27	SPIFLASH_MOSI	O	SPI flash MOSI
28	SPIFLASH_SCK	O	SPI flash CLK
29	LED_RED	O	Must be connected to the Red terminal of the indicator LED
30	LED_GREEN	O	Must be connected to the Green terminal of the indicator LED
31	PinM	I/O	I/O, please refer to Pin mux table
32	PinL	I/O	I/O, please refer to Pin mux table
33	PinK	I/O	I/O, please refer to Pin mux table
34	PinJ	I/O	I/O, please refer to Pin mux table
35	PinH	I/O	I/O, please refer to Pin mux table
36	GND	-	Ground
37	PinG	I/O	I/O, please refer to Pin mux table
38	PinF	I/O	I/O, please refer to Pin mux table
39	PinE	I/O	I/O, please refer to Pin mux table
40	PinD	I/O	I/O, please refer to Pin mux table
41	PinC	I/O	I/O, please refer to Pin mux table
42	PinB	I/O	I/O, please refer to Pin mux table
43	PinA	I/O	I/O, please refer to Pin mux table
44	VDDA	PI	MCU analog power and reference, must be connected to VDD
45	VBAT	PI	MCU retention RAM and RTC backup supply
46	PinY	I/O	I/O, please refer to Pin mux table
47	GND	-	Ground
48	PinV	I/O	I/O, please refer to Pin mux table
49	GND	-	Ground
50	DNC	-	Do not connect
51	GND	-	Ground
52	RESET_L	I	MCU reset, internally pulled up
53	GND	-	Ground
54	GND	-	Ground



55	GND	-	Ground
56	GND	-	Ground
57	GND	-	Ground
58	PinQ	I/O	I/O, please refer to Pin mux table
59	PinR	I/O	I/O, please refer to Pin mux table
60	PinT	I/O	I/O, please refer to Pin mux table
61	PinP	I/O	I/O, please refer to Pin mux table
62	PinS	I/O	I/O, please refer to Pin mux table
63	PinU	I/O	I/O, please refer to Pin mux table
64	PinX	I/O	I/O, please refer to Pin mux table
65	VSSA	-	MCU analog ground, must be connected to GND
66-76	GND	-	Ground

### 4.3. Pin Mux Table

Pin	uartFG	uartQRPW	uartUVGD	uartWJ	uartDM	i2cFG	i2cAB	spiEBCA	spiLGDK	ADC	DAC	PWM	Wake from sleep	State change callback	Pin trig pulse gen
Pin A							SCL	nSS		yes	yes			yes	
Pin B							SDA	MISO		yes		yes		yes	
Pin C								SCLK		yes	yes	yes		yes	
Pin D			CTS		TX				SCLK					yes	
Pin E								MOSI		yes		yes		yes	for C
Pin F	TX					SCL				yes		yes			for K,X
Pin G	RX		RTS			SDA			MISO					yes	
Pin H										yes					
Pin J				RX						yes					
Pin K									nSS	yes		yes			
Pin L									MOSI			yes			for G
Pin M					RX							yes		yes	for D
Pin N										yes					
Pin P		RTS												yes	
Pin Q		TX												yes	
Pin R		RX												yes	
Pin S															
Pin T														yes	
Pin U			TX											yes	
Pin V			RX											yes	
Pin W		CTS		TX						yes			yes	yes	
Pin X														yes	
Pin Y															

## 5. LED Drive

The indicator LED should be bicolor, because red, green and amber (red+green) are used to indicate status.

The LED drive pins will auto-detect common anode or common cathode parts. The detection is done by looking to see which way up the LED\_RED pin is idling at boot; to ensure this works correctly, please place a 100k resistor in parallel with the red LED.

The current drive on these pins is 20mA maximum.  
Please refer to paragraph 14 for the recommended LEDs.

<Common anode diagram>

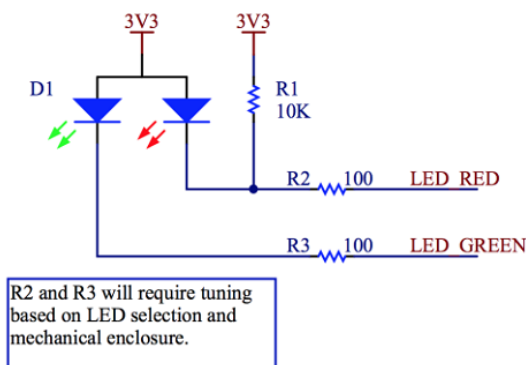

<Common cathode diagram>

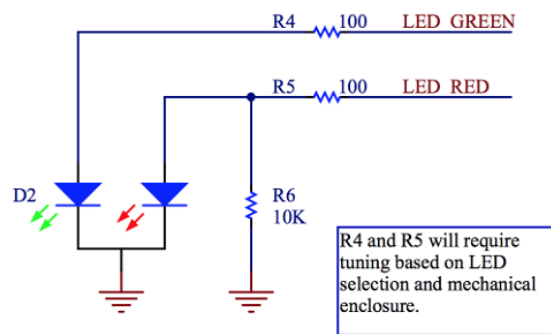

## 6. Phototransistor

The phototransistor is used to receive BlinkUp configuration data. The bias resistor connected between OPTO\_IN and GND may need to be adjusted to ensure adequate sensitivity and response time - in general you need at least 500mV swing on the OPTO\_IN pin between black and white states, with the worst (dimpest) BlinkUp sender you can find.

End-user BlinkUp send data at between 30 and 60 bits per second, depending on the user's device. For factory configuration, data is typically sent at 142 bits per second using red LED(s) in a test fixture. If your application does not require optical configuration, config can be sent electrically at 120 bits per second from another micro using the OPTO\_IN pin. Please contact us for more details.

Please refer to paragraph 14 for the recommended phototransistors.

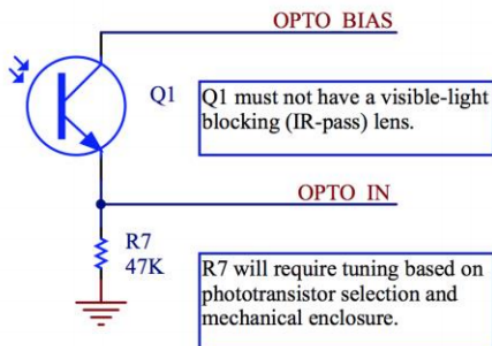

## 7. Absolute Maximum Rating

		min.	max.	unit
Storage Temperature		-40	+85	deg.C
Supply Voltage	VDD	-0.3	4	V
	VDD_PA	-0.3	6	V
	VDD_WLAN	-0.3	6	V

Stresses in excess of the absolute ratings may cause permanent damage. Functional operation is not implied under these conditions. Exposure to absolute ratings for extended periods of time may adversely affect reliability. No damage assuming only one parameter is set at limit at a time with all other parameters is set within operating condition.

## 8. Operating Condition

		min.	typ.	max.	unit
Operating Temperature Range <sup>(*1)</sup>		-40		+85	deg.C
Specification Temperature Range		-20		+70	deg.C
Supply Voltage	VDD	2.4	3.3	3.6	V
	VDD_PA	2.3 <sup>(*2)</sup>	3.3	4.8 <sup>(*2) (*3)</sup>	V
	VDD_WLAN	2.3 <sup>(*2)</sup>	3.3	4.8 <sup>(*2) (*3)</sup>	V
Backup operating Voltage	VBAT	1.65	3.3	3.6	V

[Note] All RF characteristics in this datasheet are defined by Specification Temperature Range

(\*1) Functionality is guaranteed but specifications require derating at extreme temperatures.

(\*2) The BCM43362 is functional across this range of voltage. RF performance is guaranteed only  $3.0V < VDD\_PA/WLAN < 4.8V$

(\*3) The maximum continuous voltage is 4.8V. Voltages up to 5.5V for up to 10 seconds, cumulative duration, over the lifetime of the device are allowed voltages as high 5.0V for up to 250 seconds, cumulative duration, over the lifetime of the device are allowed.

## 9. Electric characteristics

Parameter	Description	Min	Typ	Max	Unit
I <sub>DD</sub>	Normal operation, WiFi on		80	250 <sup>(*1)</sup>	mA
	Normal operation, WiFi power-save mode enabled		5	250 <sup>(*1)</sup>	mA
	WiFi is off, processor sleep, RTC on, nvram preserved		6		uA
I <sub>DDA</sub>	Current input on VDDA		70	500	uA
V <sub>IH</sub>	I/O input high level voltage	0.7V <sub>dd</sub>		3.6	V
V <sub>IL</sub>	I/O input low level voltage	V <sub>SS</sub> -0.3		0.3V <sub>dd</sub>	V
I <sub>OUT</sub>	Output current on any single I/O pin	-8		8	mA
	Output current on LED_RED pin	-20		20	mA
	Output current on LED_GREEN pin	-20		20	mA
	Total output current on all I/O pins including LED_RED & LED_GREEN	-80		-80	mA
I/O input leakage current	V <sub>SS</sub> ≤ V <sub>IN</sub> ≤ V <sub>DD</sub>			6	uA
Load capacitance	Pins A to Y		15		pF

(\*1) 250mA current is during worst-case TX events. These are a maximum of ~4.8ms long (802.11b 1Mbps)

## 10. Power Up Sequence

### 10.1. Without NRST control

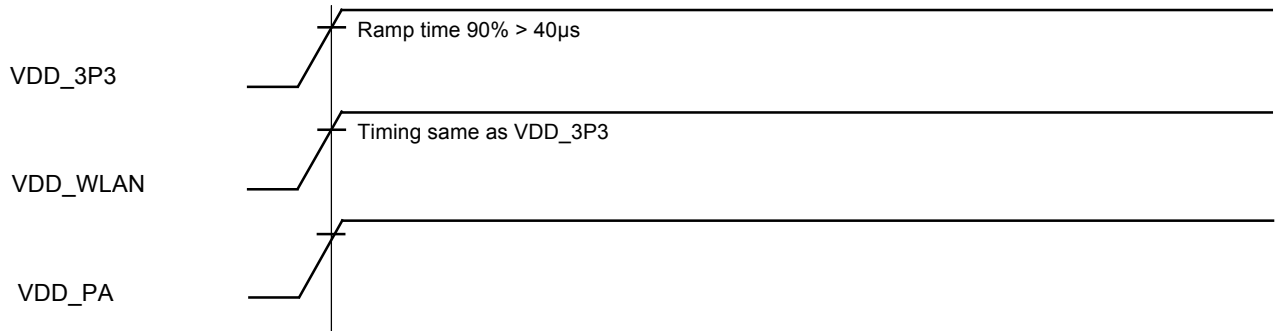

\*Power down sequence is opposite sequence of power up.

### 10.2. With NRST control

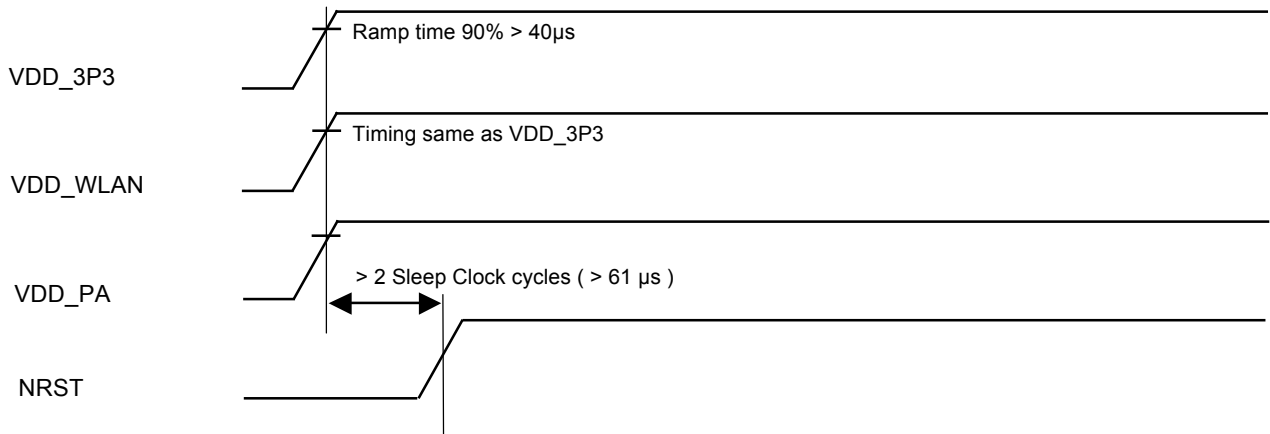

\*Power down sequence is opposite sequence of power up.

#### 10.2.1. NRST Circuit

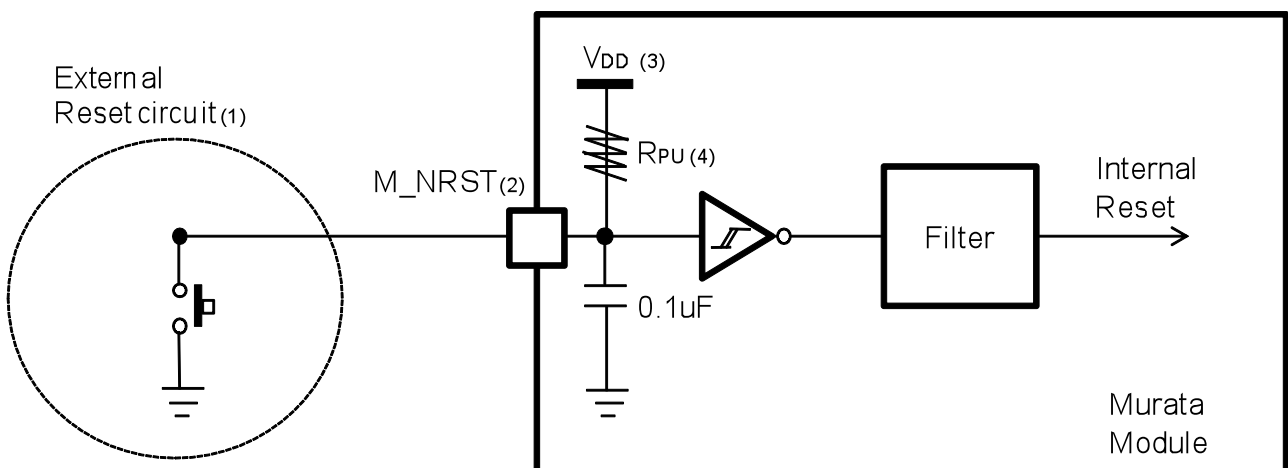

- (1) The reset network protects the device against parasitic resets.
- (2) The user must ensure that the level on the NRST pin can go below the 0.8V. Otherwise the reset is not taken into account by the device.
- (3) Vdd=3.3V(for the  $1.8 \leq Vdd \leq 3.6$  voltage range)
- (4) RPU=40k ohm (for the  $30 \leq RPU \leq 50$ kohm range)

## 11. RF Characteristics

### 11.1. RF Characteristics for IEEE802.11b (11Mbps mode unless otherwise specified.)

Conditions: 25deg.C, VDD=VDD\_WLAN=3.3V

Items	Contents			
Specification	IEEE802.11b			
Mode	DSSS / CCK			
Frequency	2400 - 2483.5MHz			
Data rate	1, 2, 5.5, 11Mbps			
Target Max Output Power	17.0			
- DC Characteristics -	min.	Typ.	max.	Unit
1. DC current				
1) Tx mode	-	TBD	TBD	mA
2) Rx mode	-	120	170	mA
- Tx Characteristics -	min.	Typ.	max.	Unit
2. Power Levels	15.0	17.0	19.0	dBm
- Rx Characteristics -	min.	typ.	max.	Unit
3. Minimum Input Level Sensitivity				
1) 11Mbps (FER $\leq$ 8%)	-	-87	-76	dBm
4. Maximum Input Level (FER $\leq$ 8%)	-10	-	-	dBm
5. Adjacent Channel Rejection (FER $\leq$ 8%)	35	-	-	dB

### 11.2. RF Characteristics for IEEE802.11g (54Mbps mode unless otherwise specified.)

Conditions: 25deg.C, VDD=VDD\_WLAN=3.3V

Items	Contents			
Specification	IEEE802.11g			
Mode	OFDM			
Frequency	2400 - 2483.5MHz			
Data rate	6, 9, 12, 18, 24, 36, 48, 54Mbps			
Target Max Output Power	13.0dBm			
- DC Characteristics -	min.	Typ.	max.	Unit
1. DC current				
1) Tx mode (1024byte, 20usec interval)	-	295	370	mA
2) Rx mode	-	125	170	mA
- Tx Characteristics -	min.	typ.	max.	unit
2. Power Levels	11.0	13.0	15.0	dBm
- Rx Characteristics -	min.	typ.	max.	Unit
3. Minimum Input Level Sensitivity				
1) 54Mbps (PER $\leq$ 10%)	-	-73	-65	dBm
4. Maximum Input Level (PER $\leq$ 10%)	-20	-	-	dBm
5. Adjacent Channel Rejection (PER $\leq$ 10%)	-1	-	-	dB

**11.3. RF Characteristics for IEEE802.11n (65Mbps(MCS7) mode unless otherwise specified.)**  
Conditions: 25deg.C, VDD=VDD\_WLAN=3.3V

Items	Contents			
Specification	IEEE802.11n			
Mode	OFDM			
Frequency	2400 - 2483.5MHz			
Data rate	6.5, 13, 19.5, 26, 39, 52, 58.5, 65Mbps			
Target Max Output Power	12.0dBm			
- DC Characteristics -	min.	Typ.	max.	Unit
1. DC current				
1) Tx mode (1024byte, 20usec interval)	-	280	350	mA
2) Rx mode	-	125	170	mA
- Tx Characteristics -	min.	typ.	max.	Unit
2. Power Levels	10.0	12.0	14.0	dBm
- Rx Characteristics -	min.	typ.	max.	Unit
3. Minimum Input Level Sensitivity				
1) 65Mbps (PER $\leq$ 10%)	-	-70	-64	dBm
4. Maximum Input Level (PER $\leq$ 10%)	-20	-	-	dBm
5. Adjacent Channel Rejection (PER $\leq$ 10%)	-2	-	-	dB

**12. Land Pattern (Top View)**

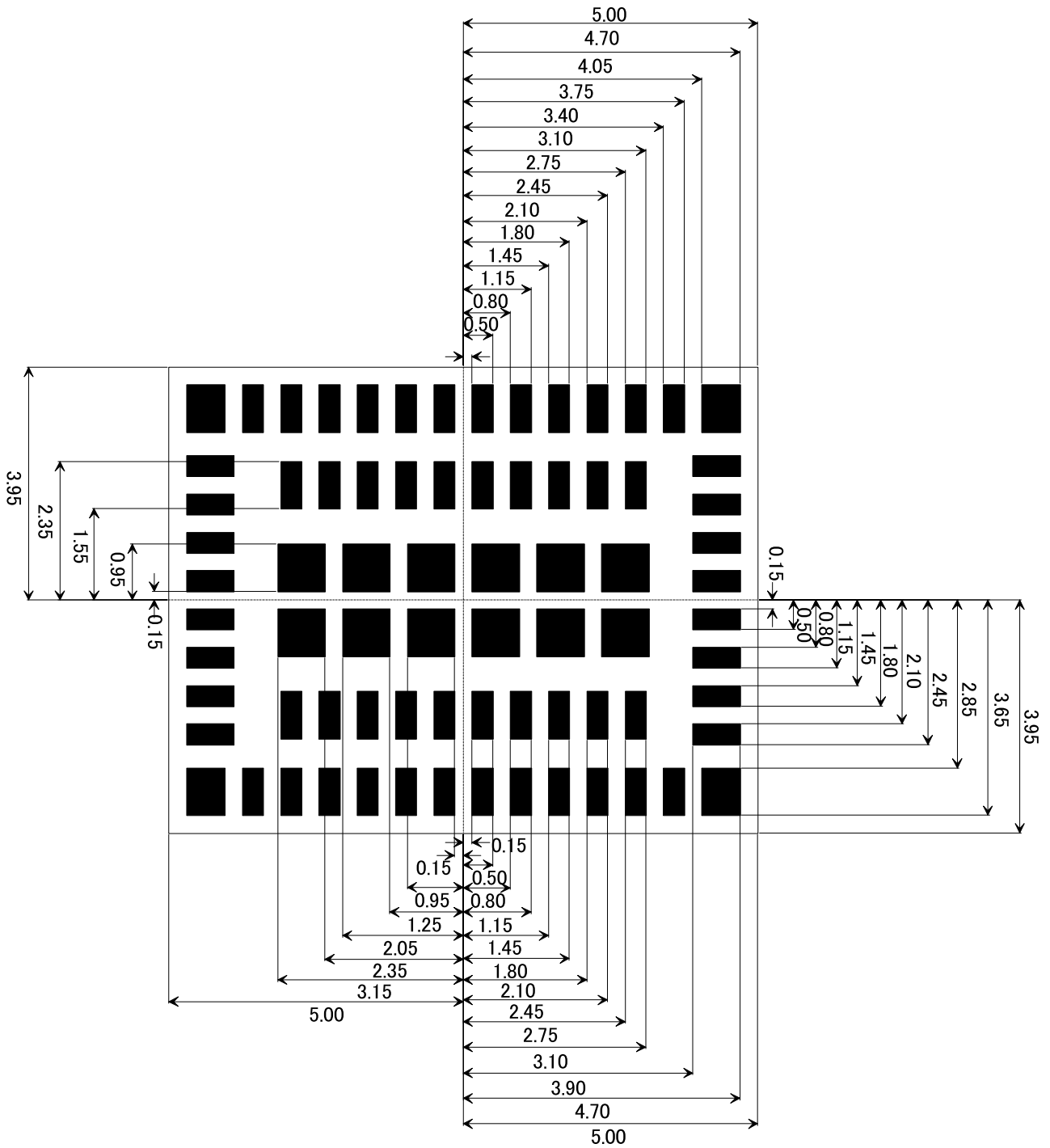

Unit : mm

### 13. Reference Circuit

#### 13.1. Low Cost Schematic

Please refer to paragraph 14 for the low cost recommended components.

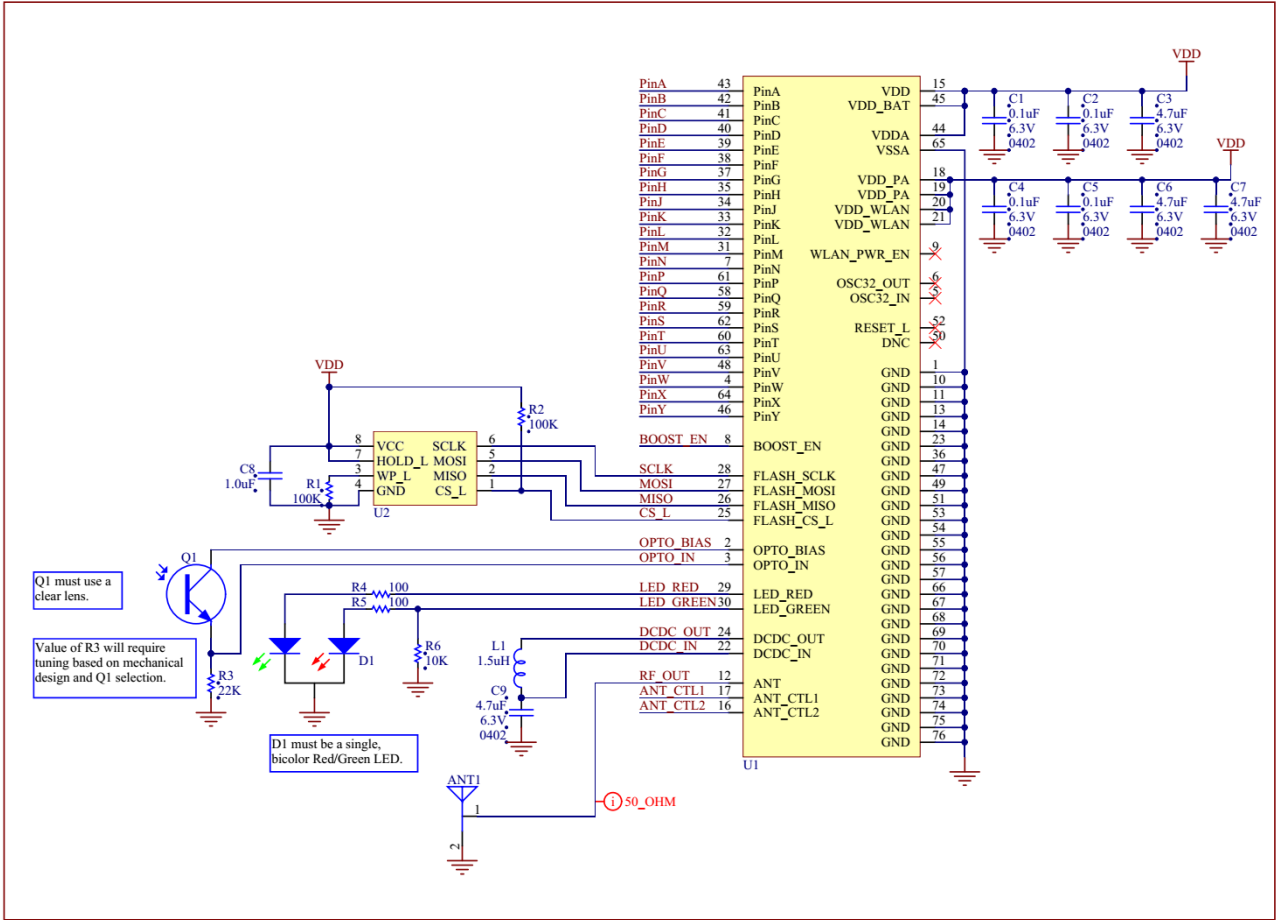



### 13.2. Low Power Schematic

Please refer to paragraph 14 for the low power recommended components.

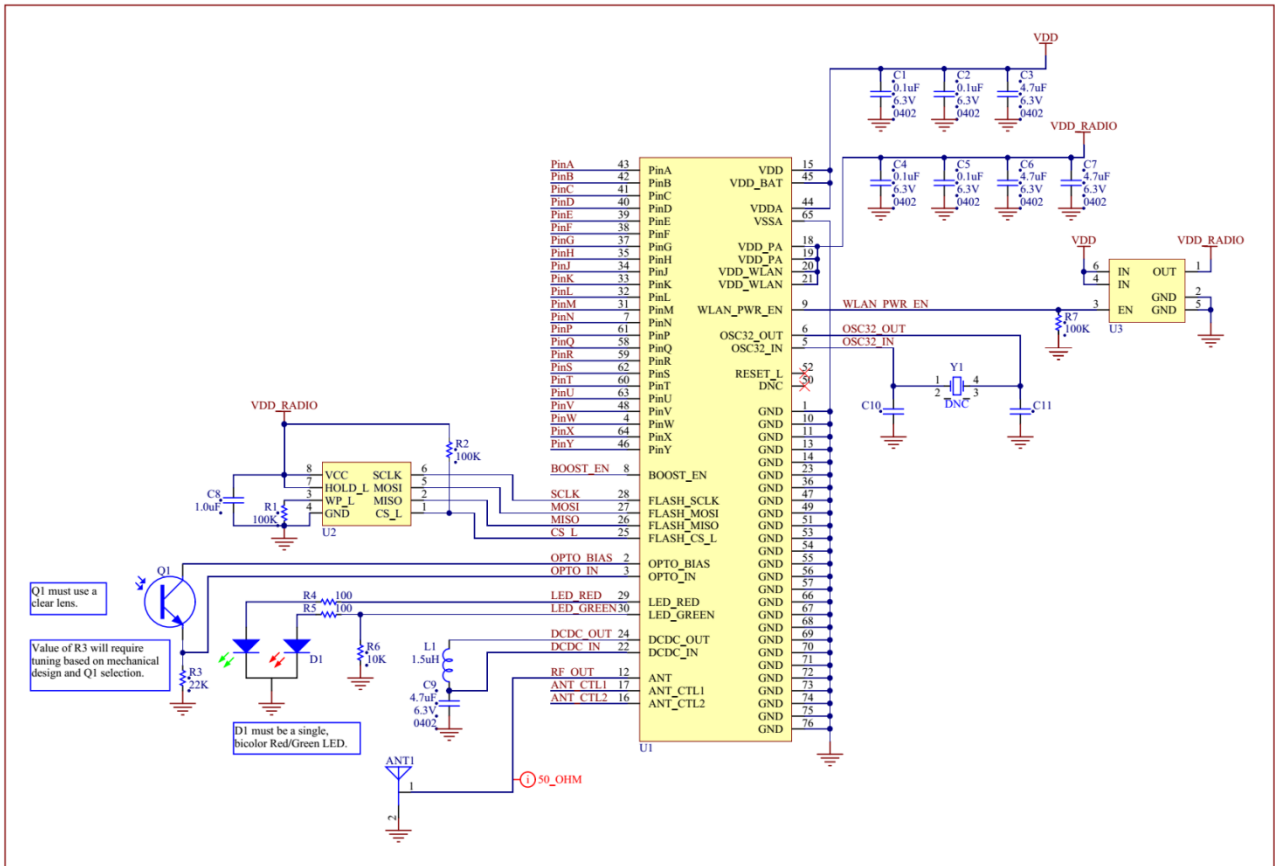

## 14. Recommended Components

### 14.1. Bi-color LED

	Manufacturer	Manufacturer's part number
<b>Surface mount</b>		
top-view	SunLED	XZMDKVG59W-1
	Liteon	LTST-C195KGJRKT
side-view	SunLED	XZMDKVG88W
	Bivar	SM1204BC
<b>Through-hole</b>		
3mm	SunLED	XLMDKVG34M
	Liteon	LTL1BEKVJNN

### 14.2. Phototransistor

	Manufacturer	Manufacturer's part number
<b>Surface mount</b>		
top-view	Everlight	PT17-21C/L41/TR8
	Kingbright	APT2012P3BT
side-view	SunLED	XZRNI56W-1
	Everlight	PT12-21C/TR8
<b>Through-hole</b>		
3mm	SunLED	XRNI30W-1
	Honeywell	SDP8405-003

### 14.3. Low Cost Schematic

Ref Des	Manufacturer	Manufacturer's part number	Description
U2	Macronix	MX25L2006E	2Mbit SPI flash
	Spansion	S24FL204K	4Mbit SPI flash
	Macronix	MX25L4006E	4Mbit SPI flash
	Spansion	S25FL132K	32Mbit SPI flash
Q1	please refer to paragraph 14.2		clear lens phototransistor
D1	please refer to paragraph 14.1		red/green bicolor LED
L1	Murata	LQM21PN1R5MC0	1.5uH inductor

### 14.4. Low Power Schematic

Ref Des	Manufacturer	Manufacturer's part number	Description
U2	Macronix	MX25L2006E	2Mbit SPI flash
	Spansion	S24FL204K	4Mbit SPI flash
	Macronix	MX25L4006E	4Mbit SPI flash
	Spansion	S25FL132K	32Mbit SPI flash
U3	Diodes Inc.	AP2281	2A load switch
Q1	please refer to paragraph 14.2		clear lens phototransistor
D1	please refer to paragraph 14.1		red/green bicolor LED
L1	Murata	LQM21PN1R5MC0	1.5uH inductor
Y1	Kyocera	ST3215SB32768B0HPWB1	32.768kHz crystal
	Abracon	ABS25-32.768KHZ-T	

## 15. Tape and Reel Packing

### (1) Dimensions of Tape (Plastic tape)

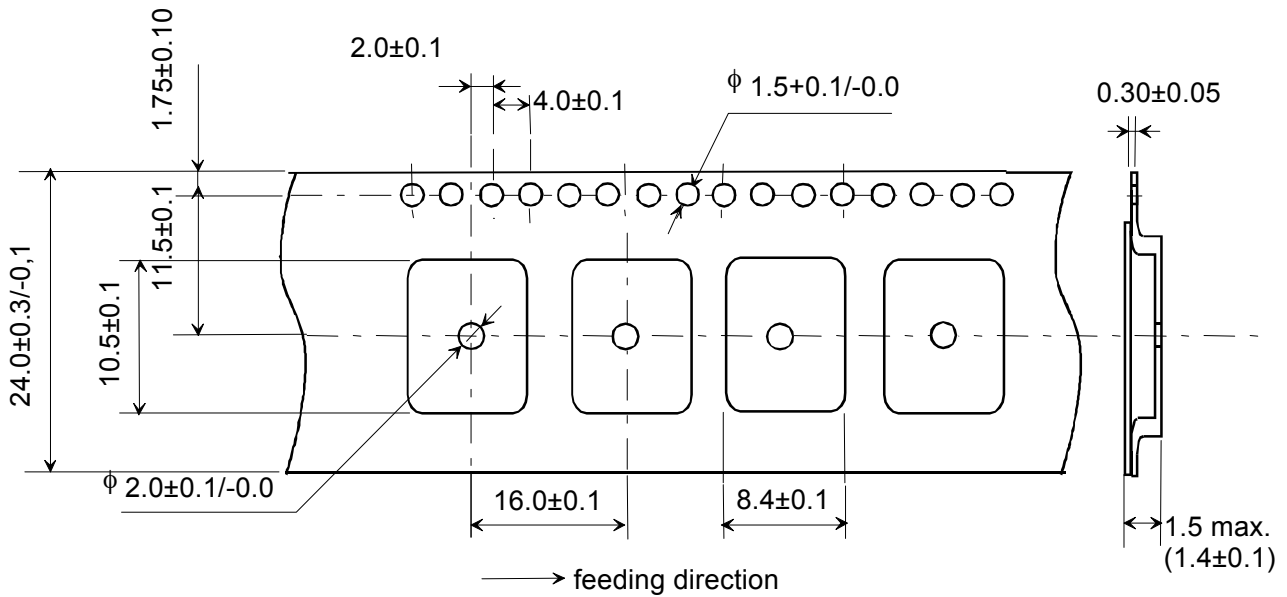

- 1) The corner and ridge radiuses (R) of inside cavity are 0.3mm max.
- 2) Cumulative tolerance of 10 pitches of the sprocket hole is  $\pm 0.2$ mm
- 3) Measuring of cavity positioning is based on cavity center in accordance with JIS/IES standard.

### (2) Dimensions of Reel

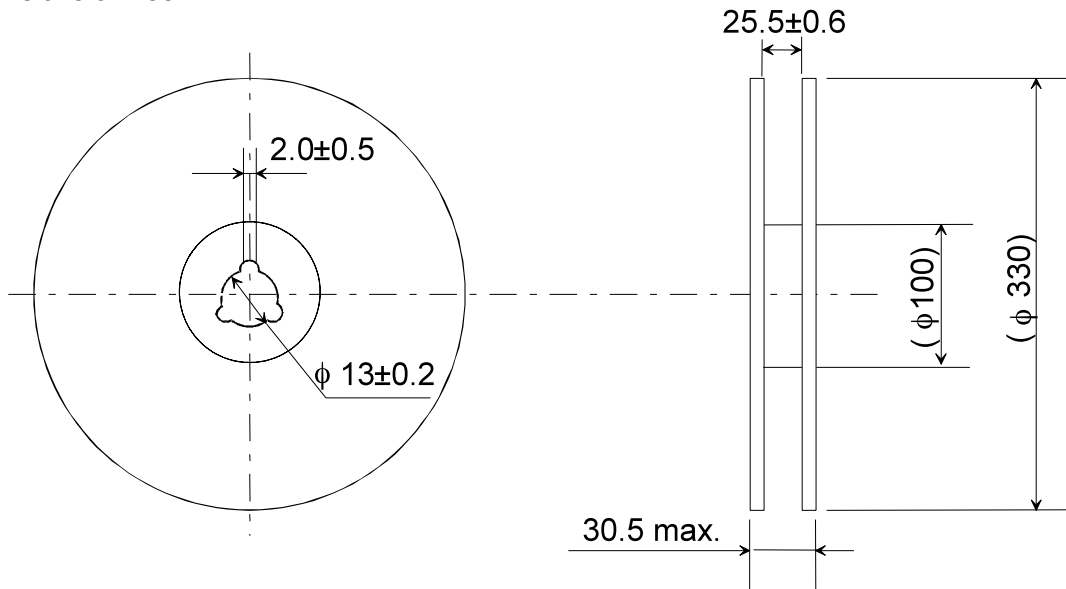

(unit : mm)

(3) Taping Diagrams

[1] Feeding Hole : As specified in (1)

[2] Hole for chip : As specified in (1)

[3] Cover tape : 62μm in thickness

[4] Base tape : As specified in (1)

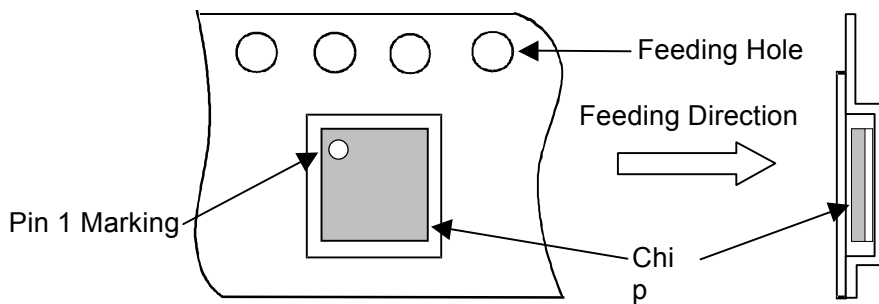
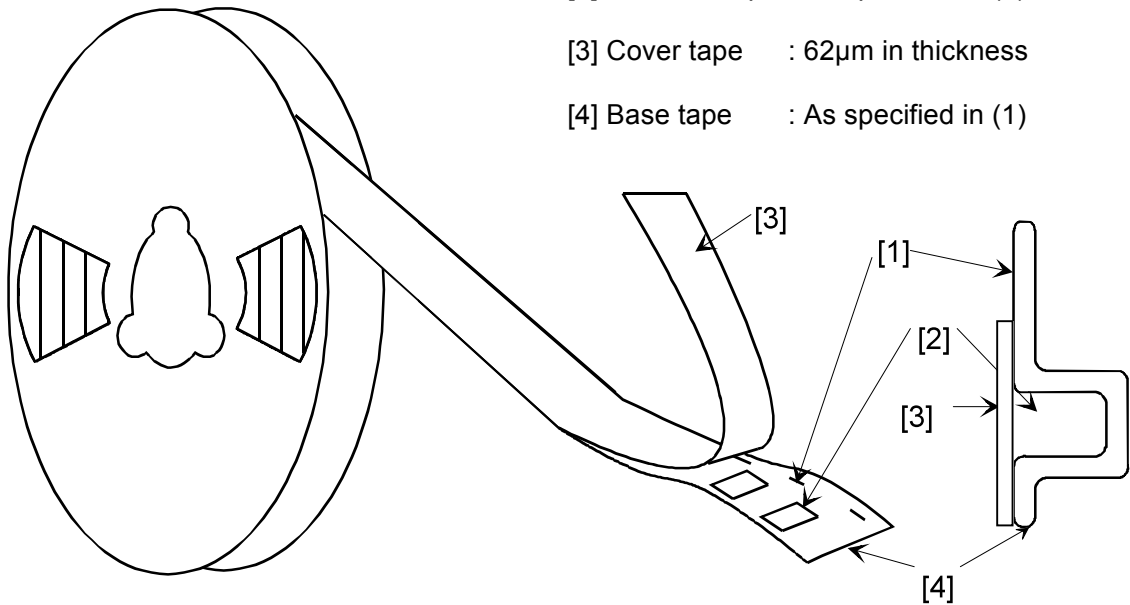

(4) Leader and Tail tape

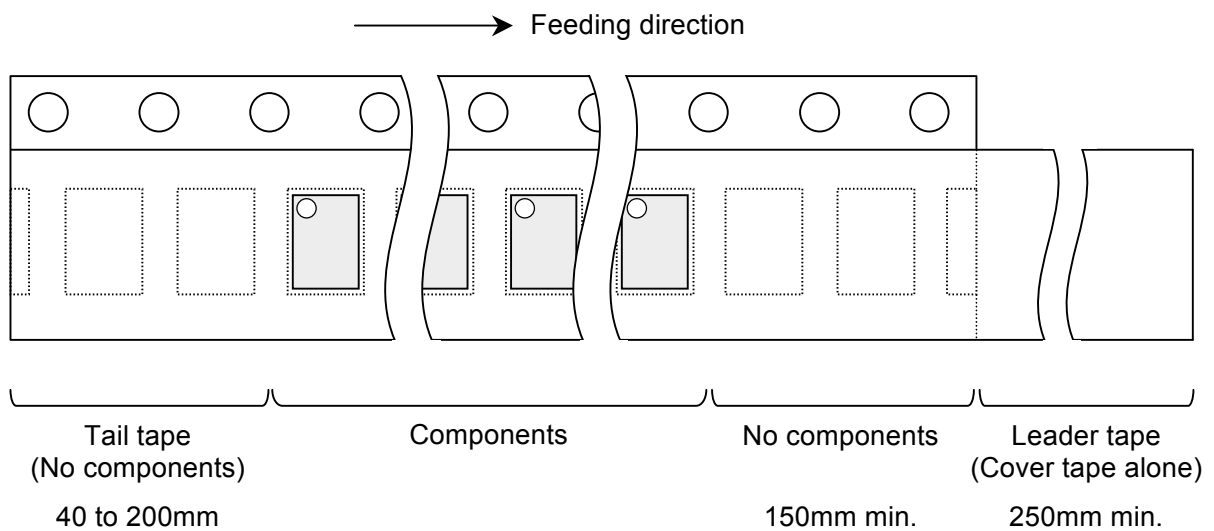

- (5) The tape for chips are wound clockwise, the feeding holes to the right side as the tape is pulled toward the user.
- (6) The cover tape and base tape are not adhered at no components area for 250mm min.
- (7) Tear off strength against pulling of cover tape : 5N min.
- (8) Packaging unit : 1000pcs./ reel
- (9) material : Base tape : Plastic  
Real : Plastic  
Cover tape, cavity tape and reel are made the anti-static processing.
- (10) Peeling of force : 0.7N max. in the direction of peeling as shown below.

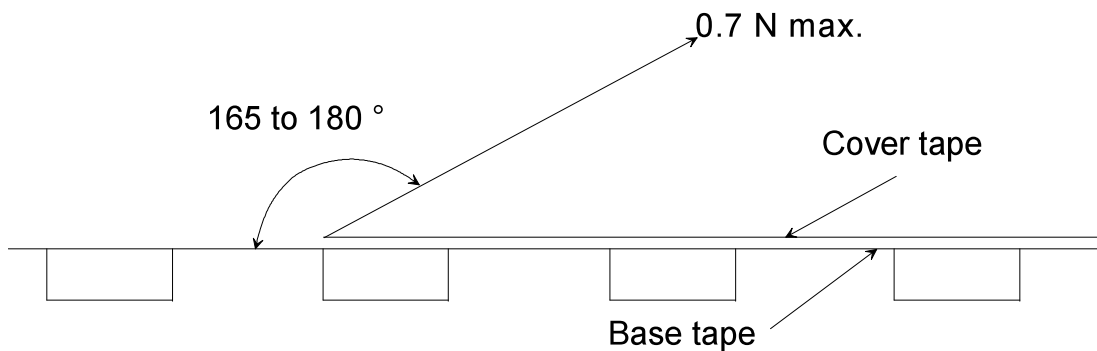

- (11) Packaging (Humidity proof Packing)

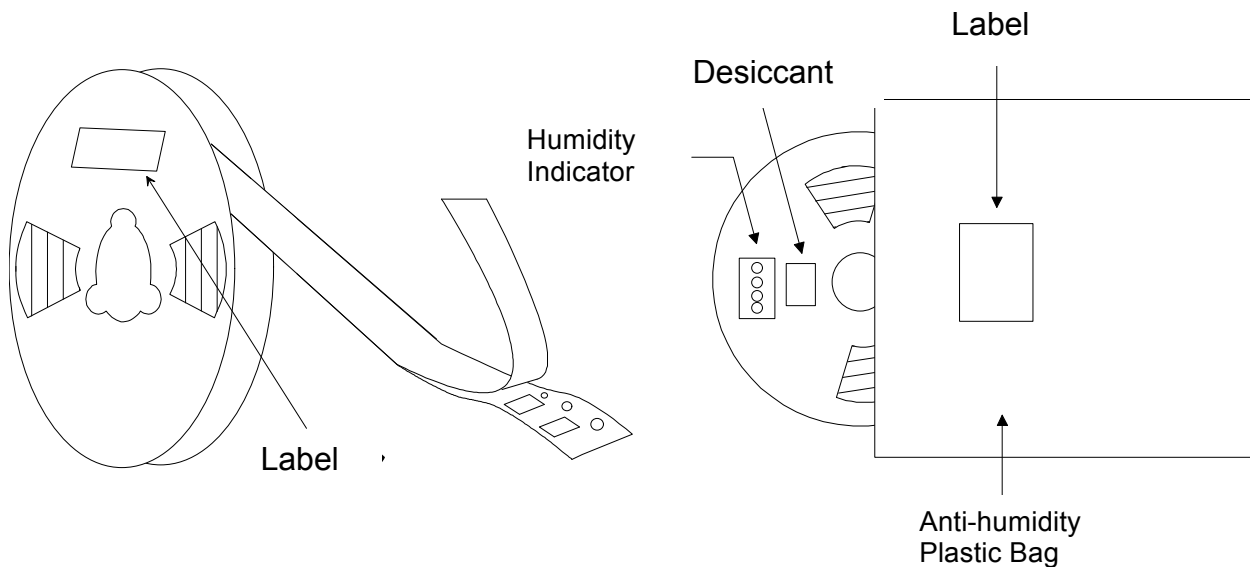

Tape and reel must be sealed with the anti-humidity plastic bag. The bag contains the desiccant and the humidity indicator.

## 16. NOTICE

### 16.1. Storage Conditions:

Please use this product within 6month after receipt.

- The product shall be stored without opening the packing under the ambient temperature from 5 to 35deg.C and humidity from 20 to 70%RH.

(Packing materials, in particular, may be deformed at the temperature over 40deg.C.)

- The product left more than 6months after reception, it needs to be confirmed the solderbility before used.

- The product shall be stored in non corrosive gas (Cl<sub>2</sub>, NH<sub>3</sub>, SO<sub>2</sub>, No<sub>x</sub>, etc.).

- Any excess mechanical shock including, but not limited to, sticking the packing materials by sharp object and dropping the product, shall not be applied in order not to damage the packing materials.

This product is applicable to MSL3 (Based on JEDEC Standard J-STD-020)

- After the packing opened, the product shall be stored at  $\leq 30$ deg.C /  $\leq 60$ %RH and the product shall be used within 168hours.

- When the color of the indicator in the packing changed, the product shall be baked before soldering.

Baking condition: 125+5/-0deg.C, 24hours, 1time

The products shall be baked on the heat-resistant tray because the material (Base Tape, Reel Tape and Cover Tape) are not heat-resistant.

### 16.2. Handling Conditions:

Be careful in handling or transporting products because excessive stress or mechanical shock may break products.

Handle with care if products may have cracks or damages on their terminals, the characteristics of products may change. Do not touch products with bear hands that may result in poor solder ability and destroy by static electrical charge.

### 16.3. Standard PCB Design (Land Pattern and Dimensions):

All the ground terminals should be connected to the ground patterns. Furthermore, the ground pattern should be provided between IN and OUT terminals. Please refer to the specifications for the standard land dimensions.

The recommended land pattern and dimensions is as Murata's standard. The characteristics of products may vary depending on the pattern drawing method, grounding method, land dimensions, land forming method of the NC terminals and the PCB material and thickness. Therefore, be sure to verify the characteristics in the actual set. When using non-standard lands, contact Murata beforehand.

### 16.4. Notice for Chip Placer:

When placing products on the PCB, products may be stressed and broken by uneven forces from a worn-out chucking locating claw or a suction nozzle. To prevent products from damages, be sure to follow the specifications for the maintenance of the chip placer being used. For the positioning of products on the PCB, be aware that mechanical chucking may damage products.

### 16.5. Soldering Conditions:

The recommendation conditions of soldering are as in the following figure.

When products are immersed in solvent after mounting, pay special attention to maintain the temperature difference within 100 °C. Soldering must be carried out by the above mentioned conditions to prevent products from damage. Set up the highest temperature of reflow within 260 °C. Contact Murata before use if concerning other soldering conditions.

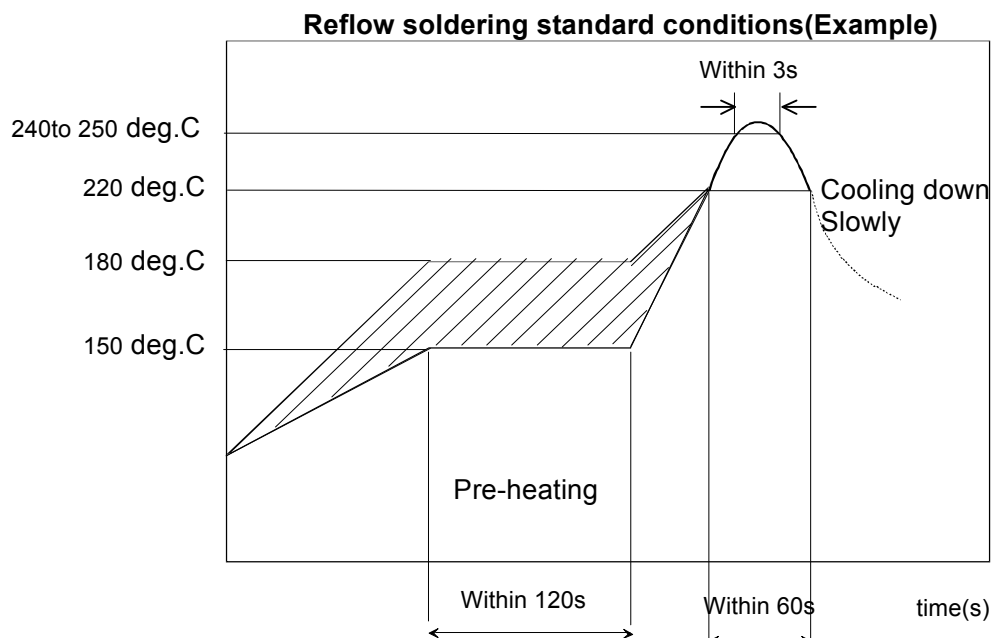

Please use the reflow within 2 times.

Use rosin type flux or weakly active flux with a chlorine content of 0.2 wt % or less.

### 16.6. Cleaning:

Since this Product is Moisture Sensitive, any cleaning is not permitted.

### 16.7. Operational Environment Conditions:

Products are designed to work for electronic products under normal environmental conditions (ambient temperature, humidity and pressure). Therefore, products have no problems to be used under the similar conditions to the above-mentioned. However, if products are used under the following circumstances, it may damage products and leakage of electricity and abnormal temperature may occur.

- In an atmosphere containing corrosive gas ( Cl<sub>2</sub>, NH<sub>3</sub>, SO<sub>x</sub>, NO<sub>x</sub> etc.).
- In an atmosphere containing combustible and volatile gases.
- Dusty place.
- Direct sunlight place.
- Water splashing place.
- Humid place where water condenses.
- Freezing place.

If there are possibilities for products to be used under the preceding clause, consult with Murata before actual use.

As it might be a cause of degradation or destruction to apply static electricity to products, do not apply static electricity or excessive voltage while assembling and measuring.

### 16.8. Input Power Capacity:

Products shall be used in the input power capacity as specified in this specifications.

Inform Murata beforehand, in case that the components are used beyond such input power capacity range.

## **17. PRECONDITION TO USE OUR PRODUCTS**

PLEASE READ THIS NOTICE BEFORE USING OUR PRODUCTS.

Please make sure that your product has been evaluated and confirmed from the aspect of the fitness for the specifications of our product when our product is mounted to your product.

All the items and parameters in this product specification/datasheet/catalog have been prescribed on the premise that our product is used for the purpose, under the condition and in the environment specified in this specification. You are requested not to use our product deviating from the condition and the environment specified in this specification.

Please note that the only warranty that we provide regarding the products is its conformance to the specifications provided herein. Accordingly, we shall not be responsible for any defects in products or equipment incorporating such products, which are caused under the conditions other than those specified in this specification.

WE HEREBY DISCLAIMS ALL OTHER WARRANTIES REGARDING THE PRODUCTS, EXPRESS OR IMPLIED, INCLUDING WITHOUT LIMITATION ANY WARRANTY OF FITNESS FOR A PARTICULAR PURPOSE, THAT THEY ARE DEFECT-FREE, OR AGAINST INFRINGEMENT OF INTELLECTUAL PROPERTY RIGHTS.

The product shall not be used in any application listed below which requires especially high reliability for the prevention of such defect as may directly cause damage to the third party's life, body or property. You acknowledge and agree that, if you use our products in such applications, we will not be responsible for any failure to meet such requirements. Furthermore, YOU AGREE TO INDEMNIFY AND DEFEND US AND OUR AFFILIATES AGAINST ALL CLAIMS, DAMAGES, COSTS, AND EXPENSES THAT MAY BE INCURRED, INCLUDING WITHOUT LIMITATION, ATTORNEY FEES AND COSTS, DUE TO THE USE OF OUR PRODUCTS IN SUCH APPLICATIONS.

- Aircraft equipment.
- Aerospace equipment
- Undersea equipment.
- Power plant control equipment
- Medical equipment.
- Transportation equipment (vehicles, trains, ships, elevator, etc.).
- Traffic signal equipment.
- Disaster prevention / crime prevention equipment.
- Burning / explosion control equipment
- Application of similar complexity and/ or reliability requirements to the applications listed in the above.

We expressly prohibit you from analyzing, breaking, reverse-engineering, remodeling altering, and reproducing our product. Our product cannot be used for the product which is prohibited from being manufactured, used, and sold by the regulations and laws in the world.

We do not warrant or represent that any license, either express or implied, is granted under any our patent right, copyright, mask work right, or our other intellectual property right relating to any combination, machine, or process in which our products or services are used. Information provided by us regarding third-party products or services does not constitute a license from us to use such products or services or a warranty or endorsement thereof. Use of such information may require a license from a third party under the patents or other intellectual property of the third party, or a license from us under our patents or other intellectual property.

Please do not use our products, our technical information and other data provided by us for the purpose of developing of mass-destruction weapons and the purpose of military use.

Moreover, you must comply with "foreign exchange and foreign trade law", the "U.S. export administration regulations", etc.

Please note that we may discontinue the manufacture of our products, due to reasons such as end of supply of materials and/or components from our suppliers.

By signing on specification sheet or approval sheet, you acknowledge that you are the legal representative for your company and that you understand and accept the validity of the contents herein. When you are not able to return the signed version of specification sheet or approval sheet within 30 days from receiving date of specification sheet or approval sheet, it shall be deemed to be your consent on the content of specification sheet or approval sheet. Customer acknowledges that engineering samples may deviate from specifications and may contain defects due to their development status. We reject any liability or product warranty for engineering samples. In particular we disclaim liability for damages caused by

- the use of the engineering sample other than for evaluation purposes, particularly the installation or integration in the product to be sold by you,
- deviation or lapse in function of engineering sample,
- improper use of engineering samples.

We disclaim any liability for consequential and incidental damages.

If you can't agree the above contents, you should inquire our sales.