

DESCRIPTION

LC1117 is a series of low dropout three-terminal regulators with a dropout of 1.26V at 1A load current.

Other than a fixed version ($V_{out} = 1.2V, 1.8V, 2.5V, 2.85V, 3.3V, 5V$), LC1117 has an adjustable version, which can provide an output voltage from 1.25 to 13.8V with only two external resistors.

LC1117 offers thermal shut down and current limit functions, to assure the stability of chip and power system. And it uses trimming technique to guarantee output voltage accuracy within $\pm 1.5\%$ (1.2V version is within $\pm 2\%$). Other output voltage accuracy can be customized on command, such as $\pm 1\%$ or $\pm 2\%$.

LC1117 is available in SOT-223, TO-252 power package.

TYPICAL APPLICATION

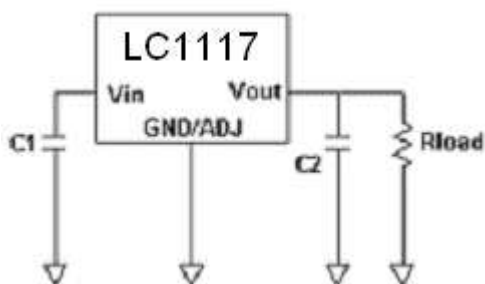

Application circuit of LC1117 fixed version

NOTE: Input capacitor ($C_{in}=10\mu F$) and Output capacitor ($C_{out}=22\mu F$) are recommended in all application circuit. Tantalum capacitor is recommended.

FEATURES

- Other than a fixed version and an adjustable version, output value can be customized on command.
- Maximum output current is 1A
- Range of operation input voltage: Max 15V
- Line regulation: 0.2%
- Load regulation: 0.4%
- Environment Temperature: $-40^{\circ}C \sim 85^{\circ}C$

APPLICATIONS

- Power Management for Computer Mother Board, Graphic Card
- LCD Monitor and LCD TV
- DVD Decode Board
- ADSL Modem
- Post Regulators for Switching Supplies

ELECTRICAL CHARACTERISTICS

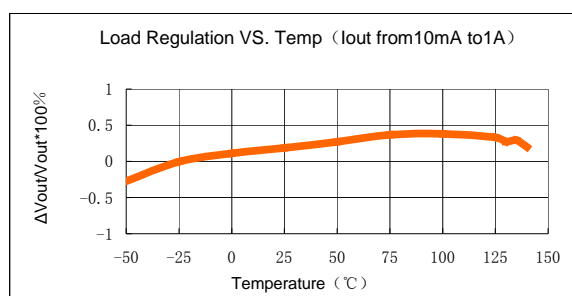

LC1117

ORDERING INFORMATION

LC1117 [1](#) [2](#) [3](#) [4](#) [5](#)

Code	Description
1	Temperature&Rohs: C:-40~85°C ,Pb Free Rohs Std.
2	Package type: L:SOT-223 O:TO-252
3	Packing type: TR:Tape&Reel (Standard)
4	Output voltage: e.g. 12=1.2V 18=1.8V AD=Output adjustable
5	Voltage accuracy: 1=±1%(Customized) Blank(default)=±1.5% 2=±2%(Customized)

ABSOLUTE MAXIMUM RATING

Parameter	Value	
Max Input Voltage	15V	
Operating Junction Temperature(Tj)	125°C	
Ambient Temperature(Ta)	-40°C –85°C	
Package Thermal Resistance	SOT-223	20°C / W
	TO-252	12.5°C / W
Storage Temperature(Ts)	-40°C -150°C	
Lead Temperature & Time	260°C,10S	

Note:

Exceed these limits to damage to the device.
Exposure to absolute maximum rating conditions may affect device reliability.

PIN CONFIGURATION

Product Classification		LC1117CLTR□□
Marking		
1117 B XXYYZZ	1117:Product Code	
	B:Fab Code	
	XX: Output Voltage	
	YY:Lot No.	
	ZZ:Data Code	
Product Classification		LC1117COTR□□
1117 B XXYYZZ	1117:Product Code	
	B:Fab Code	
	XX: Output Voltage	
	YY:Lot No.	
	ZZ:Data Code	
Vss/Adj	Ground Pin/Adjustable	
Vin	Supply Voltage Input	
Vout	Output Voltage	

RECOMMENDED WORK CONDITIONS

Parameter	Value
Input Voltage Range	Max.15V
Ambient Temperature	-40°C –85°C

ELECTRICAL CHARACTERISTICS

T_j=25°C

Symbol	Parameter	Conditions	Min	Typ	Max	Unit
V _{ref}	Reference Voltage	I _{out} =10mA, V _{in} -V _{out} =2V 10mA ≤ I _{out} ≤ 1A, 1.5V ≤ V _{in} -V _{out} ≤ 12V	1.231 1.225	1.25 1.25	1.268 1.275	V
V _{out}	Output Voltage	LC1117-1.20V I _{out} =10mA, V _{in} =3.2V, T _j =25°C 0 ≤ I _{out} ≤ 1A, 3.0V ≤ V _{in} ≤ 12V	1.176 1.14	1.20 1.20	1.224 1.248	V
		LC1117-1.80V I _{out} =10mA, V _{in} =3.8V, T _j =25°C 0 ≤ I _{out} ≤ 1A, 3.2V ≤ V _{in} ≤ 12V	1.773 1.764	1.80 1.80	1.827 1.836	V
		LC1117-2.5V I _{out} =10mA, V _{in} =4.5V, T _j =25°C 0 ≤ I _{out} ≤ 1A, 3.9V ≤ V _{in} ≤ 12V	2.462 2.45	2.5 2.5	2.538 2.55	V
		LC1117-2.85V I _{out} =10mA, V _{in} =4.85V, T _j =25°C 0 ≤ I _{out} ≤ 1A, 4.25V ≤ V _{in} ≤ 12V	2.807 2.793	2.85 2.85	2.893 2.907	V
		LC1117-3.3V I _{out} =10mA, V _{in} =5V, T _j =25°C 0 ≤ I _{out} ≤ 1A, 4.75V ≤ V _{in} ≤ 12V	3.250 3.234	3.3 3.3	3.349 3.366	V
		LC1117-5V I _{out} =10mA, V _{in} =7V, T _j =25°C 0 ≤ I _{out} ≤ 1A, 6.5V ≤ V _{in} ≤ 12V	4.925 4.9	5 5	5.075 5.1	V
ΔV _{out}	Line Regulation (note1)	LC1117-ADJ I _{out} =10mA, 1.5V ≤ V _{in} -V _{out} ≤ 13.775V		0.035	0.2	%
		LC1117-1.2V I _{out} =10mA, 3.0V ≤ V _{in} ≤ 15V		10	15	mV
		LC1117-1.8V I _{out} =10mA, 3.8V ≤ V _{in} ≤ 15V		10	15	mV
		LC1117-2.5V I _{out} =10mA, 3.9V ≤ V _{in} ≤ 15V		10	15	mV
		LC1117-2.85V I _{out} =10mA, 4.25V ≤ V _{in} ≤ 15V		10	15	mV
		LC1117-3.3V I _{out} =10mA, 4.75V ≤ V _{in} ≤ 15V		10	15	mV
		LC1117-5V I _{out} =10mA, 6.5V ≤ V _{in} ≤ 15V		10	15	mV

ΔV_{out}	Load Regulation (note1, 2)	LC1117-ADJ $V_{in}-V_{out}=3V, 10mA \leq I_{out} \leq 1A$		0.2	0.4	%
		LC1117-1.2V $V_{in}=3.0V, 0 \leq I_{out} \leq 1A$		8	20	mV
		LC1117-1.8V $V_{in}=3.2V, 0 \leq I_{out} \leq 1A$		8	20	mV
		LC1117-2.5V $V_{in}=3.9V, 0 \leq I_{out} \leq 1A$		8	20	mV
		LC1117-2.85V $V_{in}=4.25V, 0 \leq I_{out} \leq 1A$		8	20	mV
		LC1117-3.3V $V_{in}=4.75V, 0 \leq I_{out} \leq 1A$		8	20	mV
		LC1117-5V $V_{in}=6.5V, 0 \leq I_{out} \leq 1A$		8	20	mV
$V_{in}-V_{out}$	Dropout Voltage (note3)	$\Delta V_{out}, \Delta V_{ref}=1\%, I_{out}=100mA$		1.11	1.2	V
		$\Delta V_{out}, \Delta V_{ref}=1\%, I_{out}=500mA$		1.18	1.25	V
		$\Delta V_{out}, \Delta V_{ref}=1\%, I_{out}=1A$		1.26	1.3	V
I_{limit}	Current Limit	$V_{in}-V_{out}=2V, T_j=25^\circ C$	1	1.2	1.4	A
	Minimum Load Current (note4)	LC1117-ADJ		5	10	mA
I_q	Quiescent Current	LC1117-1.2V, $V_{in}-V_{out}=1.25V$		4	8	mA
		LC1117-1.8V, $V_{in}-V_{out}=1.25V$		4	8	mA

		LC1117-2.5V, Vin-Vout=1.25V		4	8	mA
		LC1117-2.85V, Vin-Vout=1.25V		4	8	mA
		LC1117-3.3V, Vin-Vout=1.25V		4	8	mA
		LC1117-5V, Vin-Vout=1.25V		4	8	mA
I _{Adj}	Adjust Pin Current (Adjustable Version)			55	120	μA
I _{change}	Adjust Pin Current Change			0.2		μA
	Temperature Stability				0.5	%
θ _{JC}	Thermal Resistor	SOT-223		20		°C / W
		TO-252		10		

Note1: The Parameters of Line Regulation and Load Regulation in Table1 are tested under constant junction temperature. The Curve of Load Regulation vs. Temperature is shown in typical parameter curve that follows.

Note2: When I_{out} varies between 0~1A, Vin-Vout varies between 1.5V~12V under constant junction temperature, the parameter is satisfied the criterion in table. If temperature varies between -50°C ≤ T_A ≤ 140°C, it needs output current to be larger than 10mA to satisfy the criterion.

Note3: Dropout Voltage is specified over the full output current range of the device, and it is tested under following testing conditions: First step is to find out the V_{out} value (V_{out1}) when Vin1=V_{out}+1.5V, second step is to decrease Vin (Vin2) until V_{out} value is equal to 98.5%*V_{out1} (V_{out2}). V_{dropout}=Vin2-V_{out2}.

Note4: Minimum Load Current is defined as the minimum output current required to maintain regulation. When 1.5V ≤ Vin-Vout ≤ 12V, the device is guaranteed to regulate if the output current is greater than 10mA.

BLOCK DIAGRAM

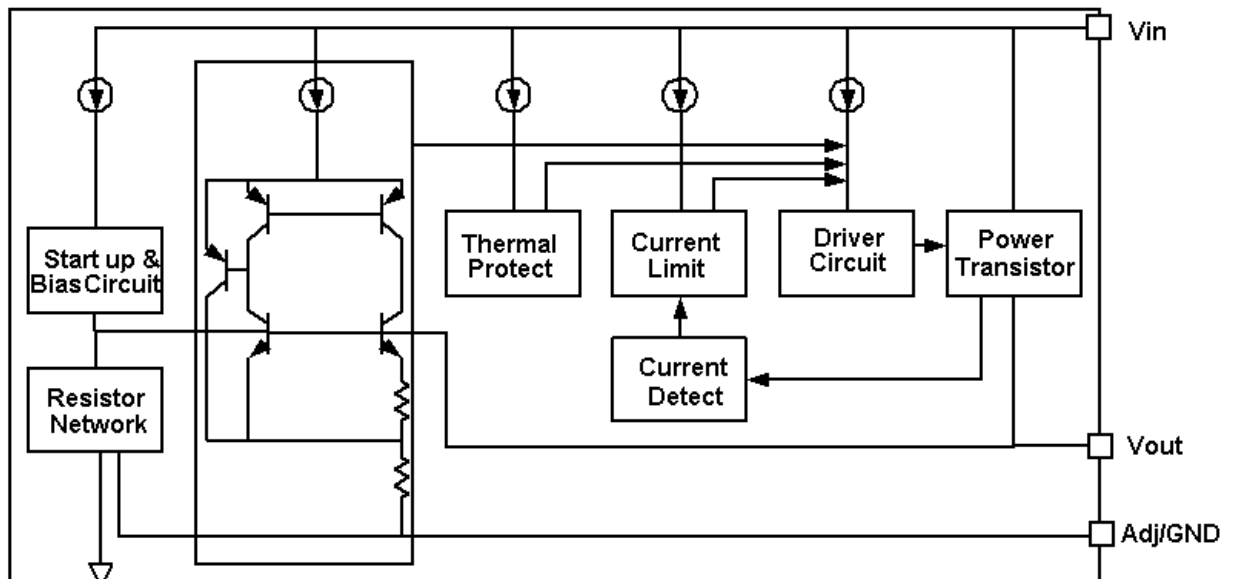

DETAILED DESCRIPTION

LC1117 is a series of low dropout voltage, three terminal regulators. Its application circuit is very simple: the fixed version only needs two capacitors and the adjustable version only needs two resistors and two capacitors to work. It is composed of some modules including start-up circuit, bias circuit, bandgap, thermal shutdown, current limit, power transistors and its driver circuit and so on.

The thermal shut down and current limit modules can assure chip and its application system working safety when the junction temperature is larger than 140°C or output current is larger than 1.2A.

The bandgap module provides stable reference voltage, whose temperature coefficient is compensated by careful design considerations. The temperature coefficient is under 100ppm/°C. And the accuracy of output voltage is guaranteed by trimming technique,

TYPICAL APPLICATION

LC1117 has an adjustable version and five fixed versions, Chart1 is its typical application:

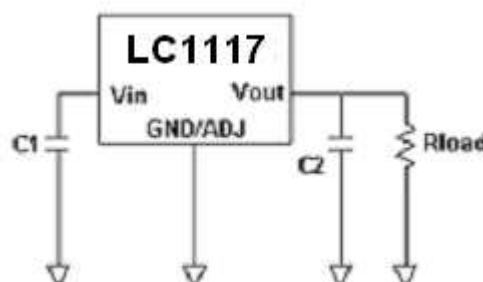

Chart 1: Application circuit of LC1117 fixed version

APPLICATION HINTS

- Recommend using 10uF tan capacitor as bypass capacitor(C1) for all application circuit.
- Recommend using 22uF tan capacitor to assure circuit stability.
- Using a bypass capacitor(CAdj) between the adjust terminal and ground can improve ripple rejection, This bypass capacitor prevents ripple from being amplified as the output voltage is increased. The impedance of CAdj should be less than the resistor's(R1) which is between output and adjust pins to prevent ripple from being amplified at any ripple frequency. As R1 is normally in the range of $200\ \Omega \sim 350\ \Omega$, the value of CAdj should satisfy this equation: $1/(2\pi * F_{ripple} * C_{adj}) < R1$. Recommend using 10uF tan capacitor.

OUTPUT VOLTAGE OF ADJUSTABLE VERSION

LC1117 adjustable version provide 1.25V Reference Voltage. Any output voltage between 1.25V~13.8V can be available by choosing two external resistors (connection method is shown in chart 2). In chart 2, R1,R2 is the two external resistors

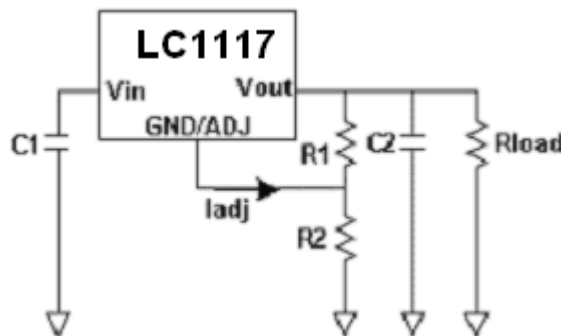

Chart 2. Application Circuit of LC1117 adjustable version

EXPLANATION

The output voltage of adjustable version satisfies this followed equation: $V_{Out} = V_{Ref} * (1 + R2/R1) + I_{Adj} * R2$. We can ignore I_{Adj} because I_{Adj} (about 50uA) is much less than the current of R1 (about 4mA).

How to choose R1: The value of R1 should be in the range of $200\ \Omega \sim 350\ \Omega$ to assure chip working normally without any load. To assure the electrical performance showed in table 1, the output current should be larger than 5mA. If R1 is too large, the minimum output current should be larger than 4mA, The best working condition is to assure that the output current exceeds 10mA.

THERMAL CONSIDERATIONS

We have to take heat dissipation into consideration when output current or differential voltage of input and output voltage is large. Because in such cases, the power dissipation consumed by LC1117 is very large. LC1117 series uses SOT-223 package type and its thermal resistance is about $20\ ^\circ\text{C}/\text{W}$. And the copper area of application board can affect the total thermal resistance. If copper area is $5\text{cm} * 5\text{cm}$ (two sides), the resistance is about $30\ ^\circ\text{C}/\text{W}$. So total thermal resistance is about $20\ ^\circ\text{C}/\text{W} + 30\ ^\circ\text{C}/\text{W}$. We can decrease total thermal resistance by increasing copper area in application board.

TYPICAL PERFORMANCE CHARACTERISTICS

1.LC1117 Dropout Voltage

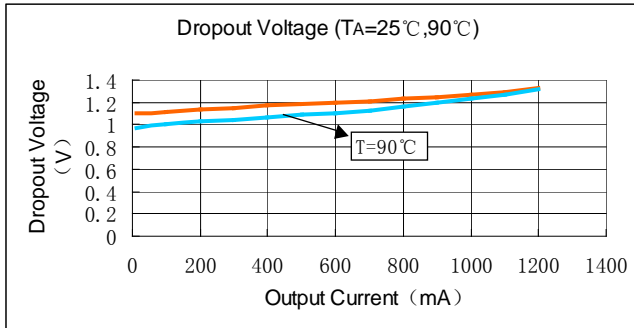

2.LC1117 Line Regulation

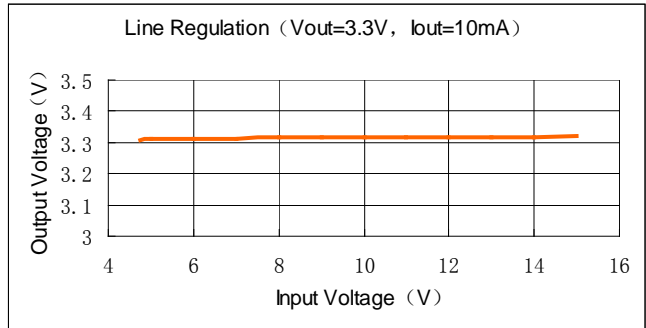

3.LC1117 Load Regulation

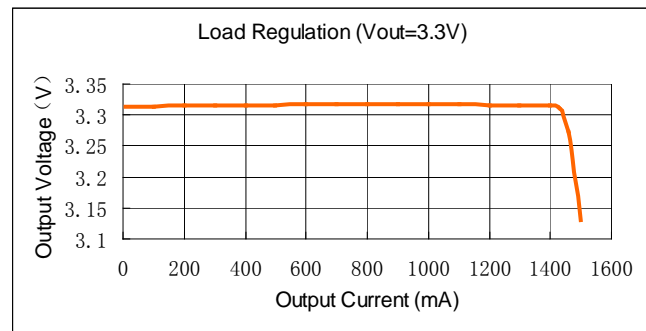
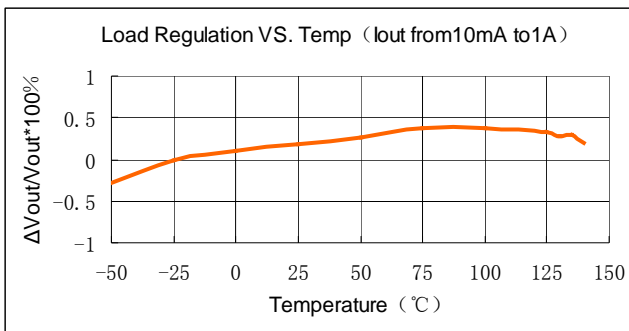

4.LC1117 Temperature Stability

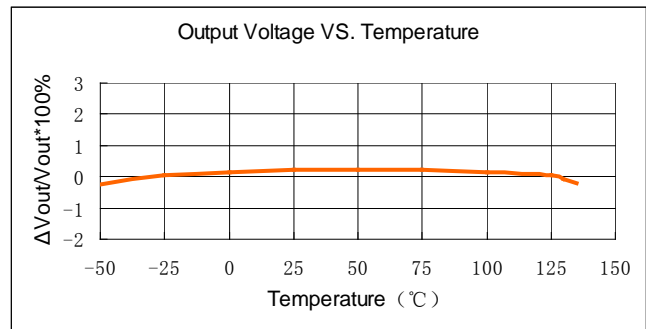
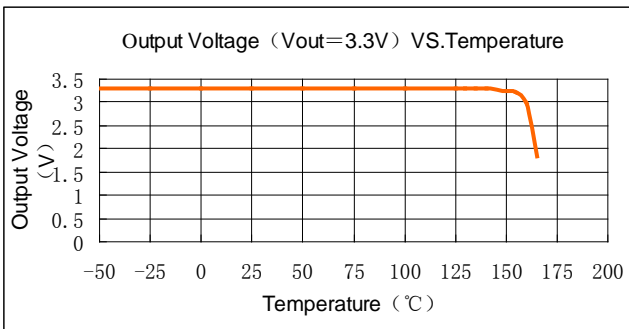

5.LC1117 Adj Pin Current VS. Temperature

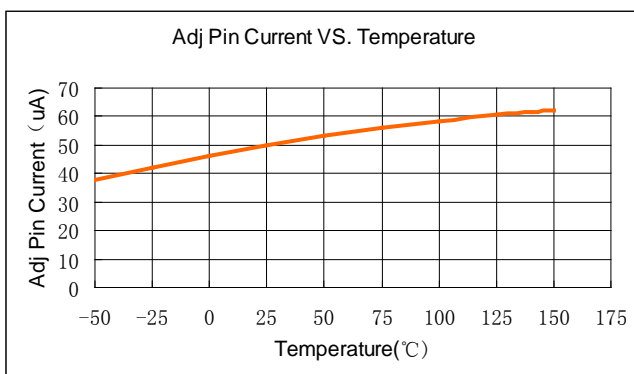

6.LC1117 Load Transient Response

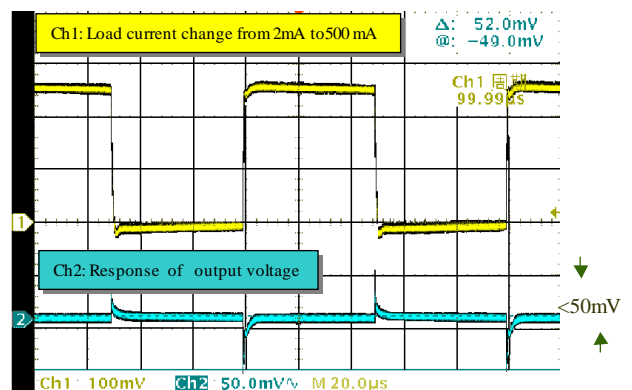

PACKAGE LINE

Package	SOT-223	Devices per reel	2500	Unit	mm
<p>Package specification:</p> <p>The technical drawing consists of three views of the SOT-223 package:</p> <ul style="list-style-type: none"> Top View: Shows a rectangular package with a central square pad. Dimensions include a total width of 6.50 ± 0.20 mm, a total height of 7.00 ± 0.30 mm, a central pad width of 3.00 ± 0.15 mm, a pad height of 3.50 ± 0.20 mm, and lead widths of 2.30 ± 0.10 mm and 0.71 ± 0.10 mm. Side View: Shows the profile of the package with a lead height of 0.90 ± 0.15 mm, a lead thickness of 0.30 ± 0.05 mm, and two radii of $R0.15 \pm 0.05$ mm. The lead is bent at a $12^\circ \pm 2^\circ$ angle. End View: Shows the package from the side with a lead height of 1.60 ± 0.10 mm, a lead thickness of 0.40 mm, a lead angle of $11^\circ \pm 2^\circ$, and a bottom lead angle of $12^\circ \pm 2^\circ$. The bottom lead thickness is 0.05 ± 0.04 mm. 					

Package	TO-252	Devices per reel	2500	Unit	mm
<p>Package specification:</p> <p>The technical drawing includes the following dimensions:</p> <ul style="list-style-type: none"> Top View: <ul style="list-style-type: none"> Overall width: 6.53 ± 0.15 Inner width: 5.33 ± 0.10 Side View (Left): <ul style="list-style-type: none"> Total height: 9.80 ± 0.30 Lead height: 0.80 ± 0.15 Lead thickness: 0.8 ± 0.05 Lead width: 2.29 ± 0.05 Lead spacing: 0.71 ± 0.07 Lead angle: $3^\circ \pm 0.10^\circ$ Side View (Right): <ul style="list-style-type: none"> Lead length: 2.28 ± 0.10 Lead thickness: 0.52 ± 0.06 Lead width: 1.20 ± 0.12 Lead spacing: 0.51 ± 0.03 Lead thickness: 0.07 ± 0.05 Lead angle: 8° Lead length: 5.46 ± 0.10 Lead thickness: 0.6 Lead angle: 5° Lead length: 1.58 ± 0.18 Lead angle: $4^\circ \pm 3^\circ$ Lead width: 0.51 Lead length: 2.80 ± 0.20 Bottom View: <ul style="list-style-type: none"> Lead angle: $0.4^\circ \times 45^\circ$ 					