

GENERAL DESCRIPTION

LC1459 series are a group of positive voltage output, high precise, and low power consumption voltage regulator. Voltages are selectable in 100mV steps within a range of 1.2V to 5.0V. It also can be customized on command.

LC1459 series have excellent load and line transient response and good temperature characteristics, which can assure the stability of chip and power system. And it uses trimming technique to guarantee output voltage accuracy within $\pm 2\%$.

LC1459 series are available in SOT-223 package, which are lead (Pb)- free.

FEATURES

- Low Quiescent Current: 100uA at 5V
- High PSRR: 70dB range to 1KHz
- Low Output Noise: 44uVRMS
- Low Dropout: 300mV at 1A load
- Maximum output current: 1.5A
- Highly Accurate: $\pm 2\%$
- Low ESR Ceramic Capacitor Compatible

APPLICATIONS

- Reference Voltage Source
- Battery Powered Equipment
- PC Peripherals
- Wireless Devices
- Instrumentation

TYPICAL APPLICATION

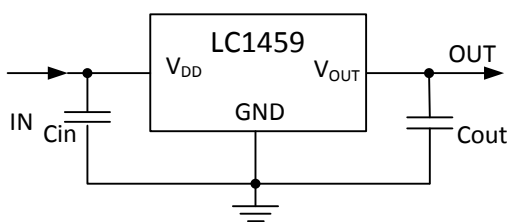

BLOCK DIAGRAM

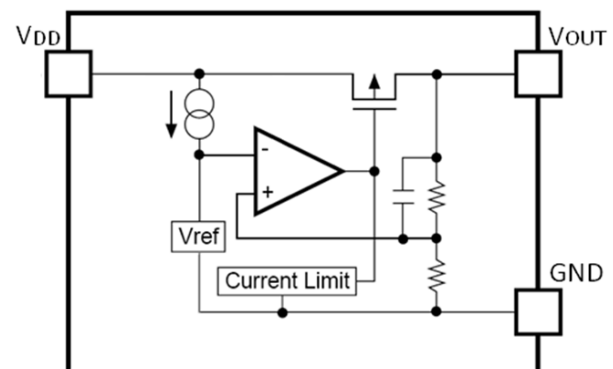

ORDERING INFORMATION

LC1459 [1](#) [2](#) [3](#) [4](#) [5](#)

Code	Description
1	Temperature&Rohs: C:-40~85°C ,Pb Free Rohs Std.
2	Package type: LA: SOT-223 (A) LB: SOT-223 (B)
3	Packing type: TR:Tape&Reel (Standard)
4	Output voltage: e.g. 12=1.2V 18=1.8V 25=2.5V 33=3.3V 50=5.0V
5	Voltage accuracy: 1=±1%(Customized) Blank(default)=±2%

ABSOLUTE MAXIMUM RATING

Parameter		Value
Max Input Voltage		8V
Max Operating Junction Temperature (T _j)		145°C
Ambient Temperature (T _A)		-40°C~85°C
Package Thermal Resistance	SOT-223	20°C / W
Storage Temperature (T _s)		-40°C~150°C
Lead Temperature & Time		260°C, 10 Sec

PIN CONFIGURATION

Product Classification		LC1459CLATR□□
JBXX LLBYW	JB:Product Code	
	XX:Output Voltage	
	A: A type	
	LL:LOT NO.	
	B:FAB Code	
YW:Date Code		
Product Classification		LC1459CLBTR□□
JBXX LLBYW	JB:Product Code	
	XX:Output Voltage	
	B: B type	
	LL:LOT NO.	
	B:FAB Code	
YW:Date Code		
VDD	Supply Voltage Input	
GND	Ground Pin	
VOUT	Output Voltage	

Y: The Year of manufacturing, "1" stands for year 2011, "2" stands for year 2012, and "8" stands for year 2018.
W: The week of manufacturing. "A" stands for week 1, "Z" stands for week 26, "A" stands for week 27, "Z" stands for week 52.

RECOMMENDED WORK CONDITIONS

Parameter	Value
Input Voltage Range	Max. 6V
Ambient Temperature	-40°C~85°C
Operating Junction Temperature (T _j)	125°C

ELECTRICAL CHARACTERISTICS

Test Conditions: $C_{IN}=4.7\mu F, C_{OUT}=4.7\mu F, T_A=25^\circ C$, unless otherwise specified.

Symbol	Parameter	Conditions	Min	Typ	Max	Units
V_{DD}	Input Voltage		1.5*		6	V
V_{OUT}	Output Voltage	$V_{OUT}>1.5$	$V_{DD}=\text{Set } V_{OUT}+1V$ $1mA \leq I_{OUT} \leq 10mA$	V_{OUT}	$V_{OUT} \times 0.98$	V
		$V_{OUT} \leq 1.5$			$V_{OUT} \times 1.02$	
$I_{OUT} \text{ (Max.)}^{**}$	Maximum Output Current	$V_{DD}-V_{OUT}=1V$	1.5			A
V_{DROD}	Dropout Voltage	$V_{OUT}=3.3V, I_{OUT}=1A$		300	500	mV
$\frac{\Delta V_{out}}{\Delta V_{in} \cdot V_{out}}$	Line Regulation	$I_{OUT}=10mA, 4V \leq V_{DD} \leq 6V$		0.05	0.2	%/V
ΔV_{out}	Load Regulation	$V_{DD}=\text{Set } V_{OUT}+1V$ $1mA \leq I_{OUT} \leq 2.5A$		30	60	mV
I_s	Supply Current	$V_{DD}=\text{Set } V_{OUT}+1V, V_{OUT}$ Floating		100	150	μA
$\frac{\Delta V_{out}}{\Delta T \cdot V_{out}}$	Output Voltage Temperature Coefficient	$I_{OUT}=10mA$		± 100		ppm/ $^\circ C$
PSRR	Ripple Rejection	$f=100Hz, \text{Ripple}=0.5Vp-p,$ $V_{DD}=\text{Set } V_{OUT}+1V$		70		dB
en	Output Noise	$BW=10Hz \sim 100KHz$		44		μV_{rms}

Note: * $I_{out}=500mA @ V_{out}=1.2V$

**The maximum power rating of each package is a constant, so along with the change of I_{LOAD} , the $V_{DD}-V_{OUT}$ should be controlled to a certain range to ensure the normal operation.

THERMAL CONSIDERATIONS

We have to take heat dissipation into great consideration when output current or differential voltage of input and output voltage is large. Because in such cases, the power dissipation consumed by LC1459 is very large. LC1459 series uses SOT-223 package type and its thermal resistance is about $20^\circ C/W$. And the copper area of application board can affect the total thermal resistance. If copper area is $5cm \times 5cm$ (two sides), the resistance is about $30^\circ C/W$. So the total thermal resistance is about $20^\circ C/W + 30^\circ C/W$. In this case, the power dissipation should be limited less than 1.2W. We can decrease total thermal resistance by increasing copper area in application board. When there is no good heat dissipation copper are in PCB, the total thermal resistance will be as high as $120^\circ C/W$, then the power dissipation of LC1459 could allow on itself is less than 1W. And furthermore, LC1459 will work at junction temperature higher than $125^\circ C$ under such condition and no lifetime is guaranteed.

CURRENT LIMIT MODE

Current Limit module can keep chip and power system away from danger when the load current is higher than the current limit threshold. When V_{out} decrease the Short Circuit Current will fold back to a small value.

SHORT CIRCUIT PROTECTION

When V_{out} short to GND, the short circuit protection will be triggered and clamp the output current to approximately 400mA. This feature protects the regulator from over current and damage due to overheating.

TYPICAL PERFORMANCE CHARACTERISTICS

Load Regulation
(Vout=3.3V)

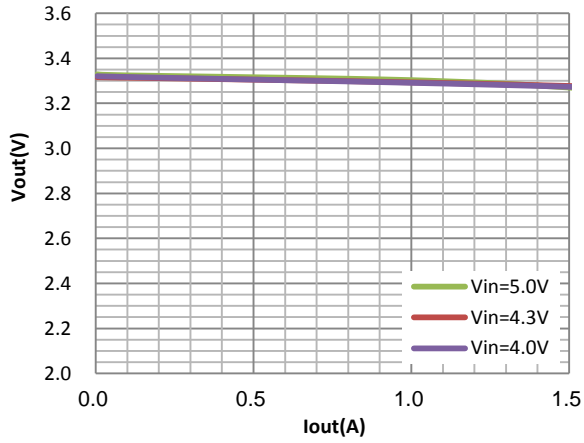

Load Regulation
(Vout=1.2V)

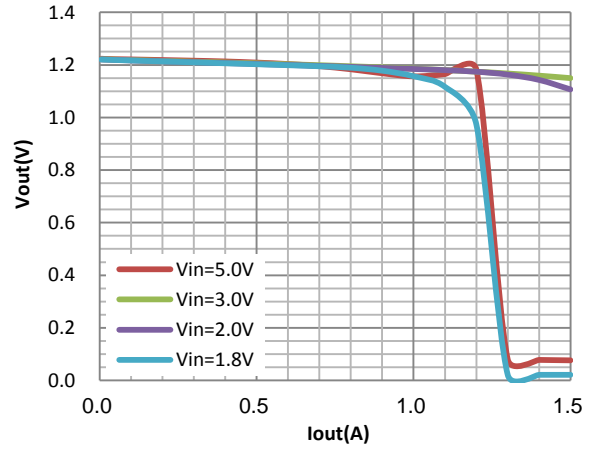

Line Regulation

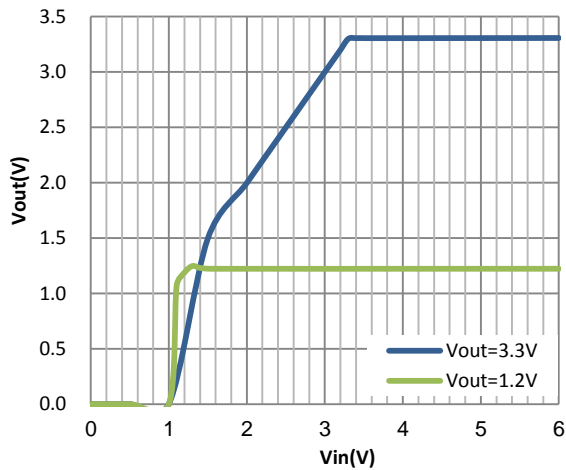

Iq

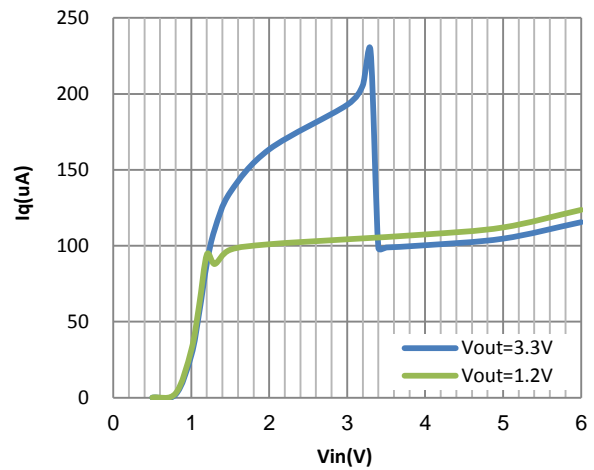

Dropout Voltage

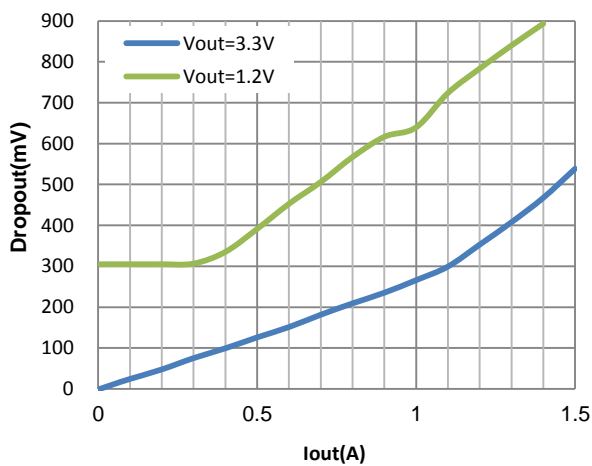

Vout vs. Temperature

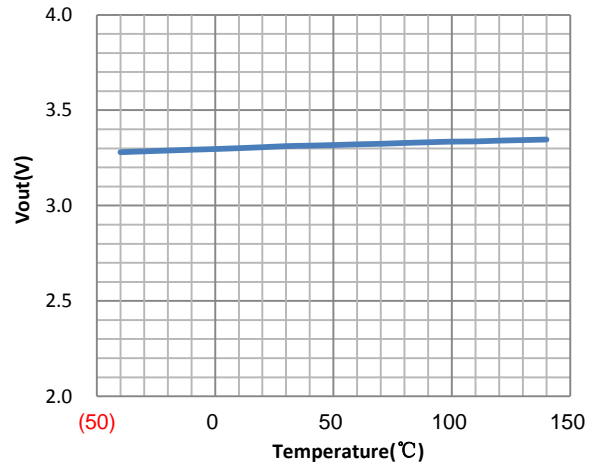

Load Transient Response (Vin=5V, Vout=3.3V) Cin=1uF, Cout=1uF, Iout=1mA-100mA

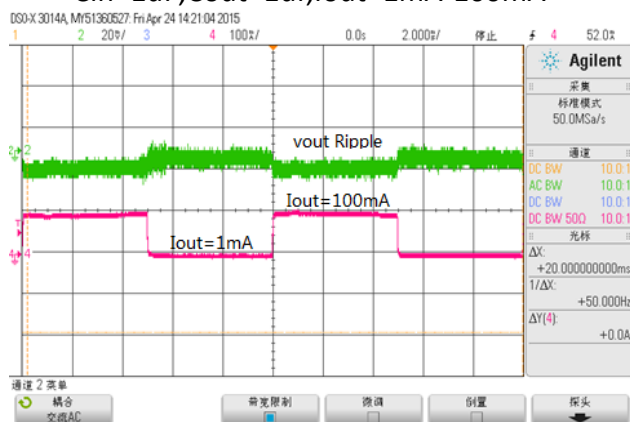

Line Transient Response (Vin=5V, Vout=3.3V) Cin=1uF, Cout=1uF, Iout=10mA, Vin=4.3V-5.3V

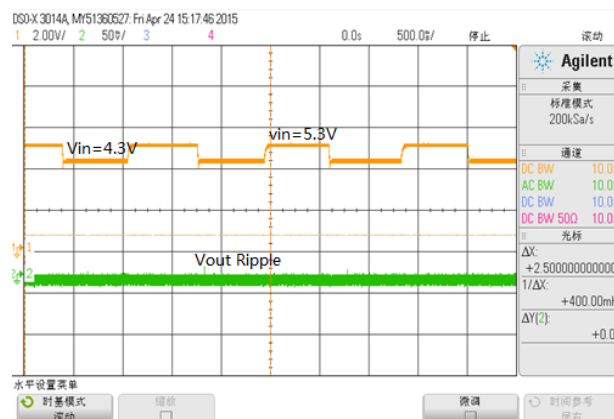

PACKAGE LINE

Package	SOT-223	Devices per reel	2500Pcs	Unit	mm
---------	---------	------------------	---------	------	----

Package specification:

SECTION C-C

SECTION D-D

COMMON DIMENSIONS
(UNITS OF MEASURE=MILLIMETER)

SYMBOL	MIN	NOM	MAX
A	-	-	1.80
A1	0.02	-	0.10
A2	1.50	1.60	1.70
A3	0.80	0.90	1.00
b	0.67	-	0.80
b1	0.66	0.71	0.76
b2	2.96	-	3.09
b3	2.95	3.00	3.05
c	0.30	-	0.35
c1	0.29	0.30	0.31
D	6.48	6.53	6.58
D1	6.55	6.60	6.65
D2	-	-	7.05
E	6.80	-	7.20
E1	3.40	3.50	3.60
E2	3.33	3.43	3.53
e	2.30BSC		
e1	4.60BSC		
L	0.80	1.00	1.20
L1	1.75REF		
L2	0.25BSC		
R	0.10	-	-
R1	0.10	-	-
theta	0°	-	8°
theta_1	10°	12°	14°

NOTES:
ALL DIMENSIONS REFER TO JEDEC STANDARD TO261-AA