

Product Specification

SPECIFICATION FOR APPROVAL

- () Preliminary Specification
 () Final Specification

Title	20.0" WXGA TFT LCD
--------------	---------------------------

BUYER	
MODEL	-

SUPPLIER	LG.Philips LCD Co., Ltd.
*MODEL	LC200WX1
SUFFIX	SLB1

*When you obtain standard approval,
 please use the above model name without suffix

APPROVED BY	SIGNATURE DATE
/	
/	
/	

APPROVED BY	SIGNATURE DATE
J.H Yoon / Senior Manager	
REVIEWED BY	
H.I Jang / Manager	
PREPARED BY	
D.W Lee / Engineer	

Please return 1 copy for your confirmation with
 your signature and comments.

**TV Product Development Dept.
 LG. Philips LCD Co., Ltd**

Product Specification

Contents

Number	ITEM	Page
	COVER	1
	CONTENTS	2
	RECORD OF REVISIONS	3
1	GENERAL DESCRIPTION	4
2	ABSOLUTE MAXIMUM RATINGS	5
3	ELECTRICAL SPECIFICATIONS	6
3-1	ELECTRICAL CHARACTERISTICS	6
3-2	INTERFACE CONNECTIONS	8
3-3	SIGNAL TIMING SPECIFICATIONS	12
3-4	SIGNAL TIMING WAVEFORMS	13
3-5	COLOR INPUT DATA REFERENCE	14
3-6	POWER SEQUENCE	15
4	OPTICAL SPECIFICATIONS	17
5	MECHANICAL CHARACTERISTICS	21
6	RELIABILITY	24
7	INTERNATIONAL STANDARDS	25
7-1	SAFETY	25
7-2	EMC	25
8	PACKING	26
8-1	DESIGNATION OF LOT MARK	26
8-2	PACKING FORM	26
9	PRECAUTIONS	27
9-1	MOUNTING PRECAUTIONS	27
9-2	OPERATING PRECAUTIONS	27
9-3	ELECTROSTATIC DISCHARGE CONTROL	28
9-4	PRECAUTIONS FOR STRONG LIGHT EXPOSURE	28
9-5	STORAGE	28
9-6	HANDLING PRECAUTIONS FOR PROTECTION FILM	28

Product Specification

1. General Description

LC200WX1-SLB1 is a Color Active Matrix Liquid Crystal Display with an integral Cold Cathode Fluorescent Lamp(UCCFL) backlight system. The matrix employs a-Si Thin Film Transistor as the active element. It is a transmissive type display operating in the normally black mode. It has a 20.04 inch diagonally measured active display area with WXGA resolution (768 vertical by 1366 horizontal pixel array) Each pixel is divided into Red, Green and Blue sub-pixels or dots which are arranged in vertical stripes. Gray scale or the luminance of the sub-pixel color is determined with a 8-bit gray scale signal for each dot, thus presenting a palette of more than 16.7M(true) colors.

It has been designed to apply the 8-bit 1 port LVDS interface.

It is intended to support LCD TV, PCTV where high brightness, super wide viewing angle, high color gamut, high color depth and fast response time are important.

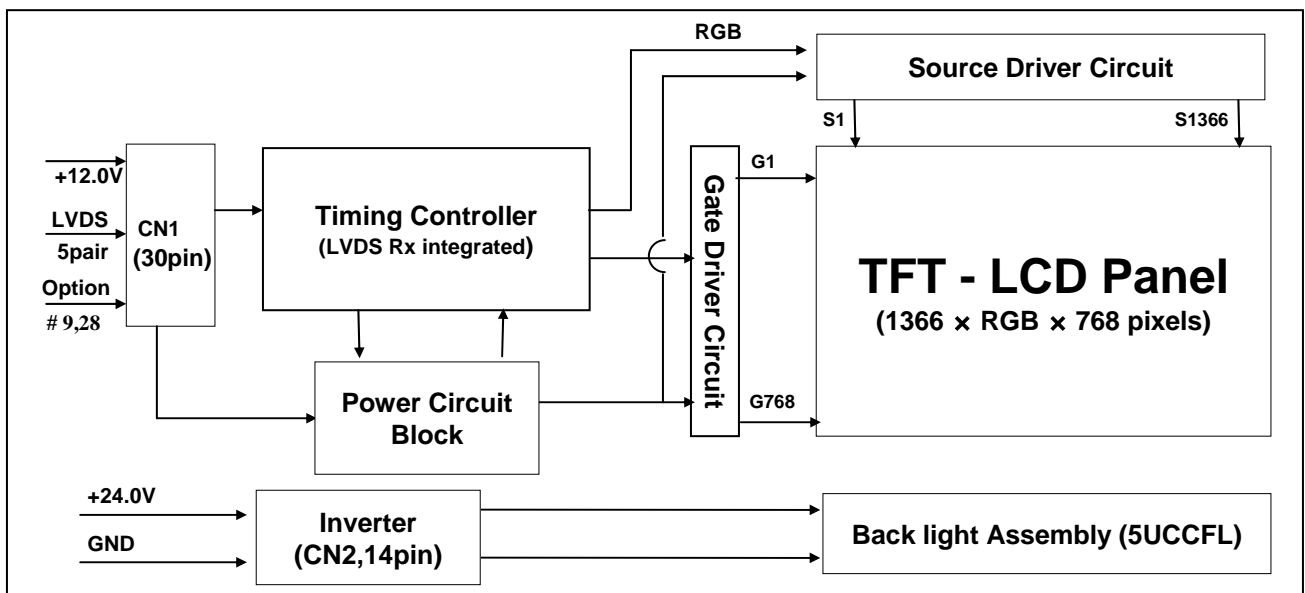

General Features

Active Screen Size	20.04 inches (509.016mm) diagonal
Outline Dimension	472.0mm(H) x 275.0mm(V) x 38.0mm(D) (Typ.)
Pixel Pitch	0.108mm x 0.324mm x RGB
Pixel Format	1366 horiz. by 768 vert. pixels RGB stripe arrangement
Color Depth	8-bit, 16.7 M colors
Luminance, White	500 cd/m ² (Center 1 point Typ.)
Viewing Angle (CR>10)	Viewing angle free (R/L 178(Typ.), U/D 178(Typ.))
Power Consumption	Total 53.40Watt (Typ.) (Logic=3.00W, Lamp=50.4W [Lamp current=6.5mA])
Weight	2,800 g (Typ.), 3,000 g (Max)
Display Operating Mode	Transmissive mode, normally black
Surface Treatment	Hard coating(3H), Anti-glare treatment of the front polarizer

Product Specification

2. Absolute Maximum Ratings

The followings are maximum values which, if exceeded, may cause faulty operation or damage to the unit.

Table 1. ABSOLUTE MAXIMUM RATINGS

Parameter		Symbol	Value		Unit	Remark
			Min	Max		
Power Input Voltage	LCM	VLCD	-0.3	14.0	V _{DC}	at 25 ± 2 °C
	Backlight inverter	VBL	-0.3	27.0	V _{DC}	
ON/OFF Control Voltage		V _{ON/OFF}	-0.3	5.25	V _{DC}	
Brightness Control Voltage		V _{BR-A}	-0.3	5.0	V _{DC}	
Operating Temperature		TOP	0	50		Note 2
Storage Temperature		TST	-20	50		Note 1
Operating Ambient Humidity		HOP	10	90	%RH	
Storage Humidity		HST	10	90	%RH	

Note : 1. Temperature and relative humidity range are shown in the figure below.
Wet bulb temperature should be 39 °C Max. and no condensation of water.

2. Gravity mura can be guaranteed under 40% condition.

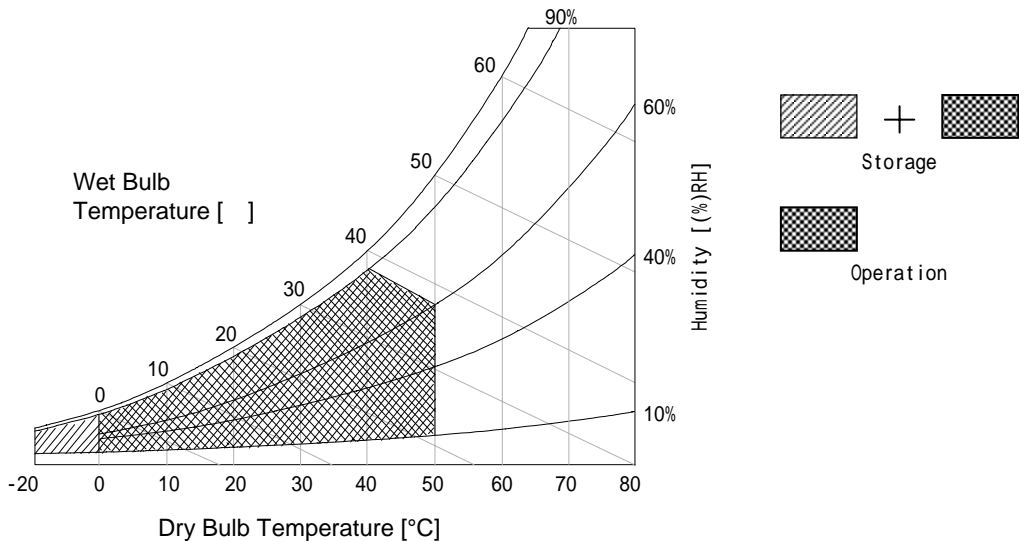

Product Specification

3. Electrical Specifications

3-1. Electrical Characteristics

It requires two power inputs. One is employed to power the LCD electronics and to drive the TFT array and liquid crystal. The other input power for the UCCFL/Backlight is to power inverter.

Table 2_1. ELECTRICAL CHARACTERISTICS

Parameter	Symbol	Value			Unit	Note
		Min	Typ	Max		
MODULE :						
Power Input Voltage	V _{LCD}	11.4	12.0	12.6	V _{Dc}	
Power Input Current	I _{LCD}	-	250	325	mA	1
		-	300	390	mA	2
Power Consumption	P _{LCD}	-	3.00	3.90	Watt	1
Rush current	I _{RUSH}	-	-	3.0	A	3

Note :

1. The specified current and power consumption are under the $V_{LCD}=12.0V$, $25 \pm 2^{\circ}C$, $f_v=60Hz$ condition whereas mosaic pattern(8 x 6) is displayed and f_v is the frame frequency.
2. The current is specified at the maximum current pattern.
3. The duration of rush current is about 2ms and rising time of power Input is 1ms(min.).

White : 255Gray

Black : 0Gray

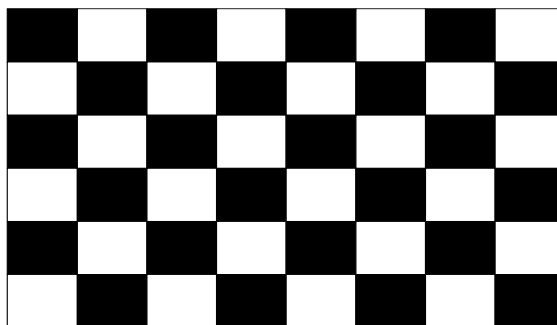

Mosaic Pattern(8 x 6)

Product Specification

Table 2_2. ELECTRICAL CHARACTERISTICS

	Description	Min	Typ	Max	Unit	Condition	Note	
1	Input Voltage	V_{BL}	22.8	24.0	25.2	Vdc		
2	Input Current	I_{BL}	-	2.1	2.4	A	$E_{xt} V_{BR-B} = 100\%$ $V_{BR-A} = MAX$	1, 3
		I_{BL}	-	1.95	2.2	A	$E_{xt} V_{BR-B} = 100\%$ $V_{BR-A} = TYP$	
3	Input Current (RUSH)	IRUSH	-	-	2.6	A	$V_{BL} = 22.8V, V_{BR-A} = Max$ $E_{xt} V_{BR-B} = 100\%$	5
4	Input Power	P_{BL}	-	50.4	57.6	W	$E_{xt} V_{BR-B} = 100\%$ $V_{BR-A} = MAX$	1, 3
5	ON/OFF Control	ON	2.0	2.5	3.3	Vdc	Lamp ON = High	
		OFF	0.0	-	0.8	Vdc	Lamp OFF =Low	
6	Analog Dimming Control Voltage	V_{BR-A}	0.0	-	3.3	Vdc		
7	Operating Frequency	FO	60	65	70	KHz		
8	PWM Frequency	F_b	145	150	155	Hz	PAL	6
			195	200	205			
			175	180	185		NTSC	
			235	240	245			
9	PWM dimming Ratio	$E_{xt} V_{BR-B}$	20	-	100	%	Reference : Onduty ratio of output current	4
10	Lamp Voltage (Output Voltage)	VOUT	590	690	790	V_{RMS}	$E_{xt} V_{BR-B} = 100\%$ $V_{BR-A} = typ$	
11	Lamp Current	IO-MAX	6.0	6.5	7.0	mA_{RMS}	$E_{xt} V_{BR-B} = 100\%$ $V_{BR-A} = Max$	
		IO-TYP	5.0	5.5	6.0	mA_{RMS}	$E_{xt} V_{BR-B} = 100\%$ $V_{BR-A} = TYP$	
		IO-MIN	4.0	4.5	5.0	mA_{RMS}	$E_{xt} V_{BR-B} = 100\%$ $V_{BR-A} = Min$	
12	Output Power	POUT	-	-	-	W	$E_{xt} V_{BR-B} = 100\%$ $V_{BR-A} = TYP$	
13	Lamp life time		50,000	-	-	Unit		2

Notes :

- The specified current and power consumption are under the typical supply Input voltage, 24.0V. The ripple voltage of the power supply input voltage is under 0.5 Vp-p.
- Specified values are for a single lamp which is aligned horizontally. The life is determined as the time at which luminance of the lamp is 50% compared to that of initial value at the typical lamp current on condition of continuous operating at $25 \pm 2^\circ C$. Specified value is when lamp is aligned horizontally.
- Electrical characteristics are determined after the unit has been 'ON' and stable for approximately 2Hrs in a dark environment at $25^\circ C \pm 2^\circ C$.
- Burst mode is controlled by TV system
- Rush current is determined at turning on after the unit has been 'OFF' for 2Hrs at $25^\circ C \pm 2^\circ C$.
- Synchronize PWM by three or four times with Vsync signal of system.

Product Specification

3-2. Interface Connections

This LCD employs two kinds of interface connection, a 30-pin connector is used for the module electronics and two 12-pin Connectors are used for the integral backlight system.

3-2-1. LCD Module

- LCD Connector(CN1) : FI-X30SSL-HF (Manufactured by JAE) or Equivalent

- Mating Connector : FI-X30C2L (Manufactured by JAE) or Equivalent

Table 3. MODULE CONNECTOR(CN1) PIN CONFIGURATION

Pin No.	Symbol	Description	Note
1	VLCD	Power Supply +12.0V	
2	VLCD	Power Supply +12.0V	
3	VLCD	Power Supply +12.0V	
4	VLCD	Power Supply +12.0V	
5	GND	Ground	
6	GND	Ground	
7	GND	Ground	
8	GND	Ground	
9	Select	Select LVDS Data format	1
10	NC	NC	
11	GND	Ground	
12	RA-	LVDS Receiver Signal(-)	
13	RA+	LVDS Receiver Signal(+)	
14	GND	Ground	
15	RB-	LVDS Receiver Signal(-)	
16	RB+	LVDS Receiver Signal(+)	
17	GND	Ground	
18	RC-	LVDS Receiver Signal(-)	
19	RC+	LVDS Receiver Signal(+)	
20	GND	Ground	
21	RCLK-	LVDS Receiver Clock Signal(-)	
22	RCLK+	LVDS Receiver Clock Signal(+)	
23	GND	Ground	
24	RD-	LVDS Receiver Signal(-)	
25	RD+	LVDS Receiver Signal(+)	
26	GND	Ground	
27	NC	NC	
28	Select	Select Inversion mode	6
29	GND	Ground	
30	NC(GND)	LCD test	2

Note: 1. If the pin no. 9 is Ground, Interface format is "LG", and if the pin no. 9 is Vcc(3.3V), Interface format is "DISM". See page 9 and 10.

2. The pin no. 30 is necessary for LCD test.

When LVDS signals are abnormal operation more than 3-Vsync times and power 12V is supplied,
'Open' or 'Vcc': LCD operate itself some test patterns.(AGP – Auto Generation Pattern)

'Ground': LCD operate itself a black pattern. (NSB – No Signal Black)

LPL recommend 'Ground' for NSB.

3. All GND (ground) pins should be connected together, which should be also connected to the LCD module's metal frame.

4. All VLCD (power input) pins should be connected together.

5. Input Levels of LVDS signals are based on the IEA 664 Standard.

6. If the pin no. 28 is 'Open' or 'Vcc', Pol period is "1 Frame" and if the pin is Ground,
Pol period is "2 Frame with gamma swing".

Product Specification

Table 4. REQUIRED SIGNAL ASSIGNMENT FOR LVDS TRANSMITTER (Pin9="L" or "Open")

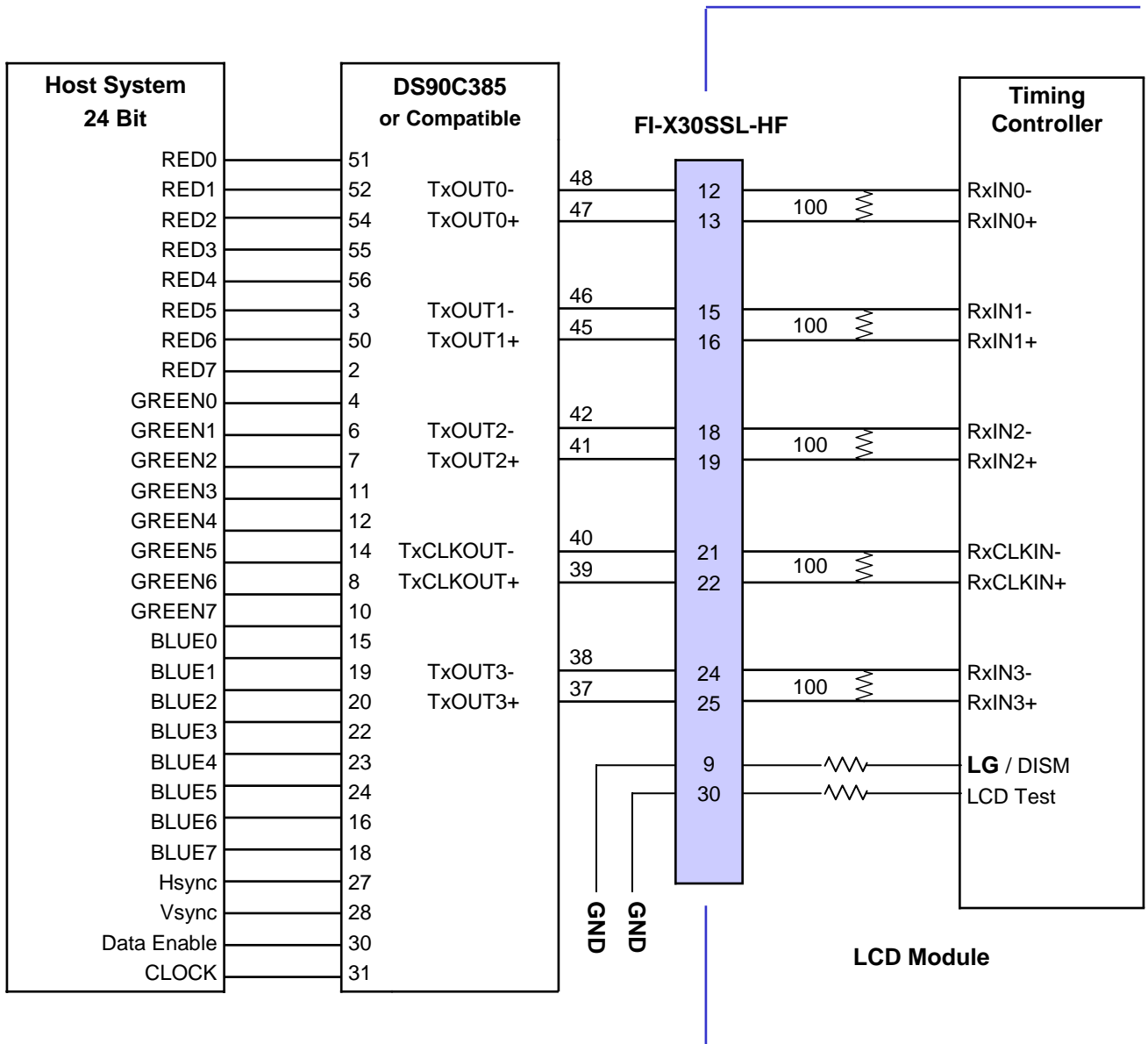

- Note: 1. The LCD Module uses a 100 Ohm[] resistor between positive and negative lines of each receiver input.
 2. Refer to LVDS Transmitter Data Sheet for detail descriptions. (DS90C385 or Compatible)
 3. '7' means MSB and '0' means LSB at R,G,B pixel data.

Product Specification

Table 5. REQUIRED SIGNAL ASSIGNMENT FOR LVDS TRANSMITTER (Pin9="H")

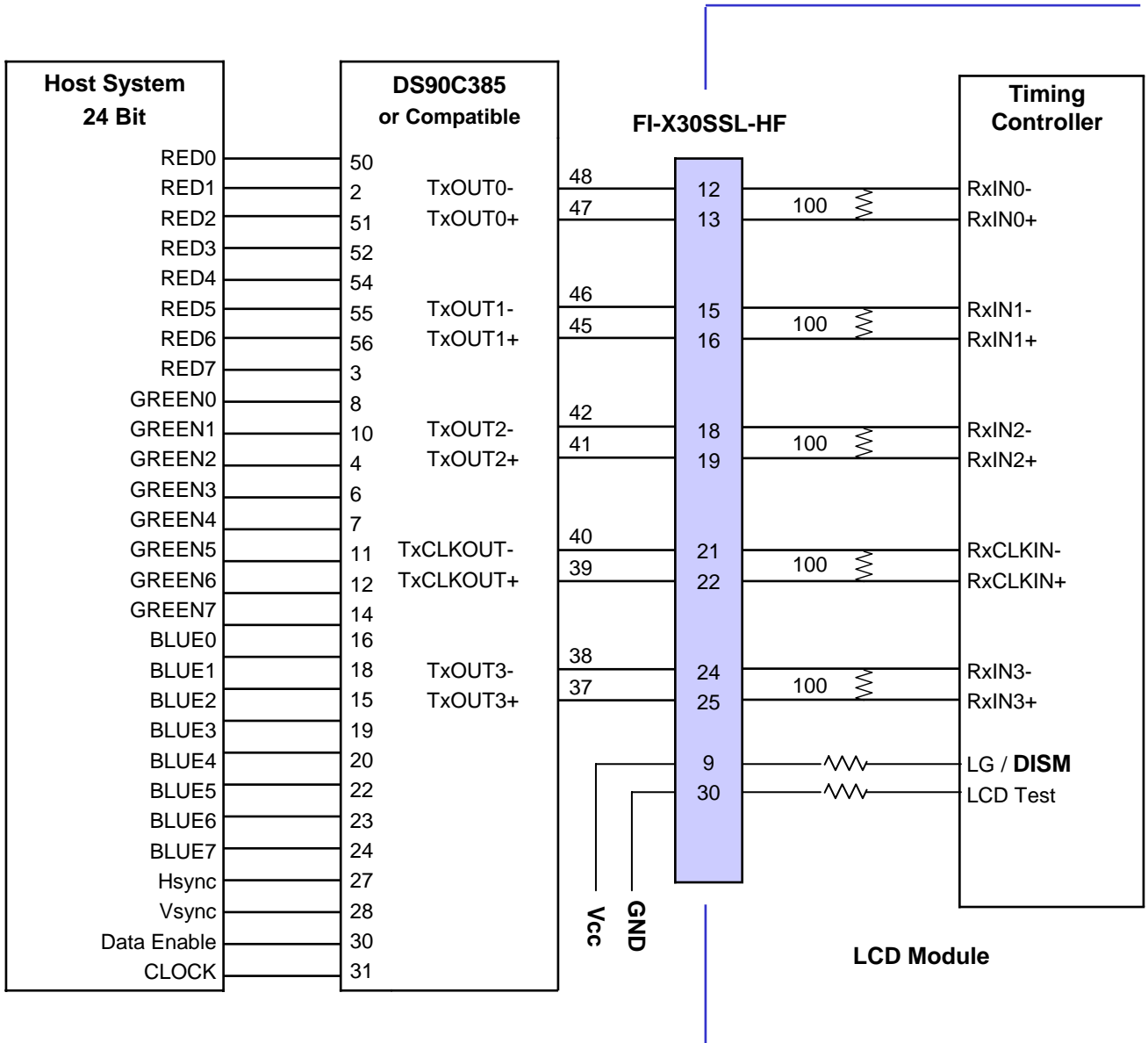

Note: 1. The LCD Module uses a 100 Ohm[] resistor between positive and negative lines of each receiver input.

2. Refer to LVDS Transmitter Data Sheet for detail descriptions. (DS90C385 or Compatible)

3. '7' means MSB and '0' means LSB at R,G,B pixel data.

Product Specification

3-3. Signal Timing Specifications

This is the signal timing required at the input of LVDS Transmitter. All of the interface signal timing should be satisfied with the following specifications for it's proper operation.

Table 7. TIMMING TABLE

Item	Symbol		Min	Typ	Max	Unit	Remark
DCLK	Period	tCLK	12.2	13.8	14.7	ns	
	Frequency	-	68	72	80	MHz	
Hsync	Period	tHP	1416	1528	1776	tCLK	
	Frequency	fH	45	47.4	50	KHz	
	Width	tWH	8	32	160	tCLK	
Vsync	Period	tVP	775	790	1063	tHP	Note 1) PAL : 47~53Hz NTSC : 57~63Hz
	Frequency	fV	47	60	63	Hz	
	Width	tWV	2	5	50	tHP	
DE (Data Enable)	Horizontal Valid	tHV	1366	1366	1366	tCLK	
	Horizontal Back Porch	tHBP	16	80	280		
	Horizontal Front Porch	tHFP	24	48	240		
	Horizontal Blank	-	tHP- tHV	160	tHP- tHV		
	Vertical Valid	tVV	768	768	768	tHP	
	Vertical Back Porch	tVBP	4	15	150		
	Vertical Front Porch	tVFP	1	2	120		
	Vertical Blank	-	7	22	tVP- tVV		

Note: Hsync period and Hsync Width should be even number times of tCLK. If the value is odd number times of tCLK, display control signal can be asynchronous. In order to operate this LCD module, Hsync, Vsync, and DE(Data Enable) signals should be used.

1. : The performance of the electro-optical characteristics may be influenced by variance of the vertical refresh rate.
2. Vsync and Hsync should be keep the above specification.
3. Hsync Period, Hsync Width and Horizontal Back Porch should be any times of character number(8).

Product Specification

3-2-2. Backlight Inverter

- Inverter Connector : S14B-PH-SM3(manufactured by JST) or Equivalent
- Mating Connector : PHR-14 or Equivalent

Table 6. INVERTER CONNECTOR PIN CONFIGURATION

Pin No	Symbol	Description	Note
1	V_{BL}	Power Supply +24.0V	
2	V_{BL}	Power Supply +24.0V	
3	V_{BL}	Power Supply +24.0V	
4	V_{BL}	Power Supply +24.0V	
5	V_{BL}	Power Supply +24.0V	
6	GND	POWER GND	
7	GND	POWER GND	
8	GND	POWER GND	1
9	GND	POWER GND	
10	GND	POWER GND	
11	V_{BR-A}	Analog Dimming (0V ~ 3.3V)	2
12	On/Off	Backlight On/Off control (0V ~ 3.3V)	3
13	$E_{xt} V_{BR-B}$	PWM Dimming (Use the External PWM)	Open / High for MAX. LUM
14	Error out	Backlight status output	Normal : GND Abnormal : External pull-up

Note :

1. GND is connected to the LCD module's metal frame.

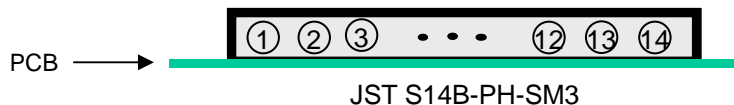

2. 0V : Minimum Brightness.
3.3V : Maximum Brightness.
1.6V : Typical Brightness (#13 : Open or 100% Dim)
3. On : 2.0 ~ 3.3V
Off : 0.0 ~ 0.8V

Product Specification

3-4. Signal Timing Waveforms

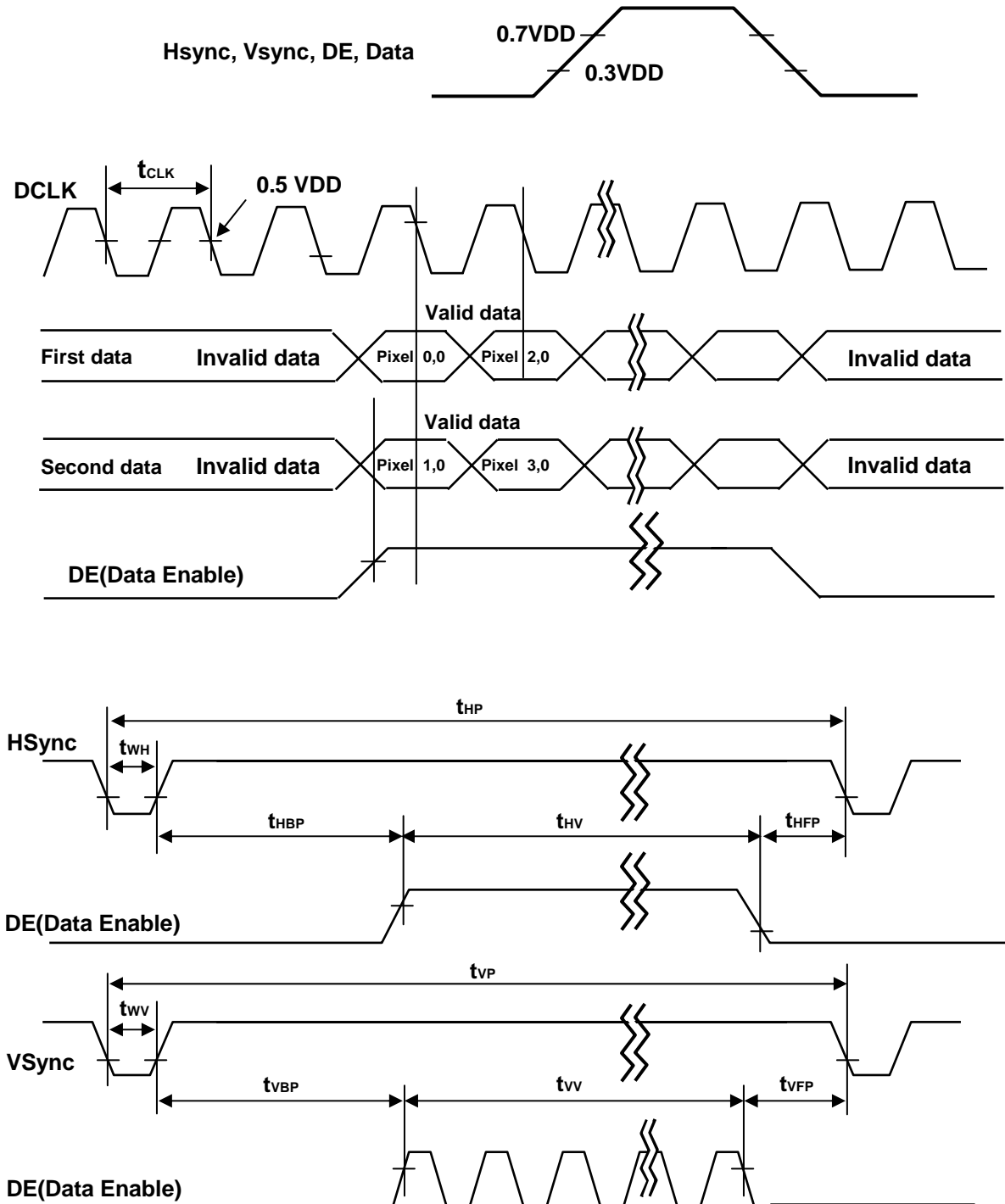



Product Specification

3-5. Color Data Reference

The brightness of each primary color(red,green,blue) is based on the 8-bit gray scale data input for the color the higher the binary input, the brighter the color. The table below provides a reference for color versus data input.

Table 8. COLOR DATA REFERENCE

Color		Input Color Data																							
		RED								GREEN								BLUE							
		MSB	LSB	MSB	LSB	MSB	LSB	MSB	LSB	MSB	LSB	MSB	LSB	MSB	LSB	MSB	LSB								
R7	R6	R5	R4	R3	R2	R1	R0	G7	G6	G5	G4	G3	G2	G1	G0	B7	B6	B5	B4	B3	B2	B1	B0		
Basic Color	Black	0	0	0	0	0	0	0	0	0	0	0	0	0	0	0	0	0	0	0	0	0	0	0	0
	Red (255)	1	1	1	1	1	1	1	1	0	0	0	0	0	0	0	0	0	0	0	0	0	0	0	0
	Green (255)	0	0	0	0	0	0	0	0	1	1	1	1	1	1	1	1	0	0	0	0	0	0	0	0
	Blue (255)	0	0	0	0	0	0	0	0	0	0	0	0	0	0	0	0	1	1	1	1	1	1	1	1
	Cyan	0	0	0	0	0	0	0	0	1	1	1	1	1	1	1	1	1	1	1	1	1	1	1	1
	Magenta	1	1	1	1	1	1	1	1	0	0	0	0	0	0	0	0	1	1	1	1	1	1	1	1
	Yellow	1	1	1	1	1	1	1	1	1	1	1	1	1	1	1	1	0	0	0	0	0	0	0	0
	White	1	1	1	1	1	1	1	1	1	1	1	1	1	1	1	1	1	1	1	1	1	1	1	1
RED	RED (000) Dark	0	0	0	0	0	0	0	0	0	0	0	0	0	0	0	0	0	0	0	0	0	0	0	0
	RED (001)	0	0	0	0	0	0	0	1	0	0	0	0	0	0	0	0	0	0	0	0	0	0	0	0
							
	RED (254)	1	1	1	1	1	1	1	0	0	0	0	0	0	0	0	0	0	0	0	0	0	0	0	0
	RED (255)	1	1	1	1	1	1	1	1	0	0	0	0	0	0	0	0	0	0	0	0	0	0	0	0
GREEN	GREEN (000) Dark	0	0	0	0	0	0	0	0	0	0	0	0	0	0	0	0	0	0	0	0	0	0	0	0
	GREEN (001)	0	0	0	0	0	0	0	0	0	0	0	0	0	0	0	1	0	0	0	0	0	0	0	0
							
	GREEN (254)	0	0	0	0	0	0	0	0	1	1	1	1	1	1	1	0	0	0	0	0	0	0	0	0
	GREEN (255)	0	0	0	0	0	0	0	0	1	1	1	1	1	1	1	1	0	0	0	0	0	0	0	0
BLUE	BLUE (000) Dark	0	0	0	0	0	0	0	0	0	0	0	0	0	0	0	0	0	0	0	0	0	0	0	0
	BLUE (001)	0	0	0	0	0	0	0	0	0	0	0	0	0	0	0	0	0	0	0	0	0	0	0	1
							
	BLUE (254)	0	0	0	0	0	0	0	0	0	0	0	0	0	0	0	0	1	1	1	1	1	1	1	0
	BLUE (255)	0	0	0	0	0	0	0	0	0	0	0	0	0	0	0	0	1	1	1	1	1	1	1	1

Product Specification

3-6. Power Sequence

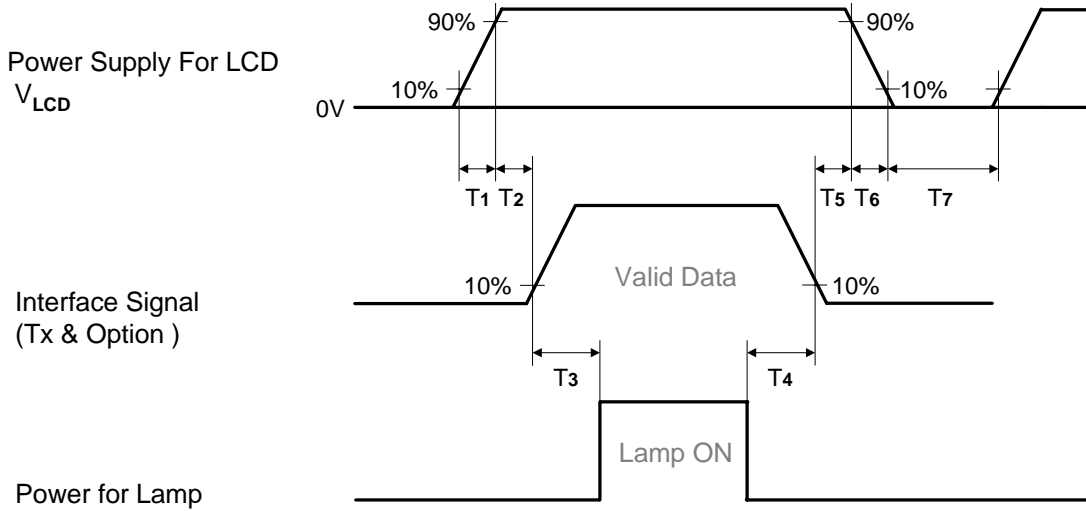

Table 9. POWER SEQUENCE

Parameter	Value			Unit
	Min	Typ	Max	
T1	0.5	-	10	ms
T2	0.5	-	50	ms
T3	200	-	-	ms
T4	200	-	-	ms
T5	0.5	-	50	ms
T6	-	-	100	ms
T7	1.0	-	-	s

Note : 1. Please avoid floating state of interface signal at invalid period.
 2. When the interface signal is invalid, be sure to pull down the power supply V_{LCD} to 0V.

Product Specification

3-6-2. Power Sequence for Inverter

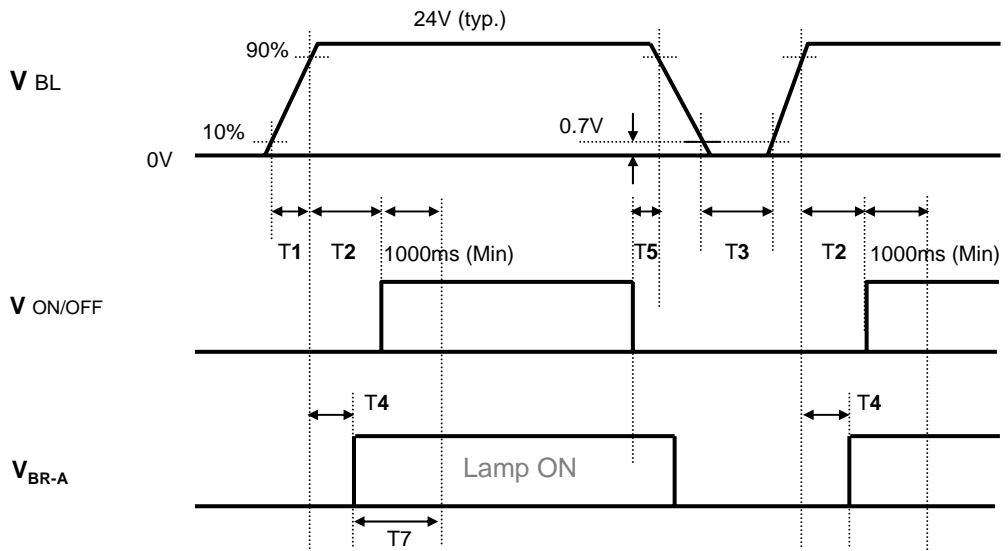

$E_{xt}V_{BR-B}$: 1. Lamp ON at PWM Rising Edge and Lamp OFF at PWM Falling Edge.
 2. EXT V_{BR-B} has Same sequence with V_{br-A}

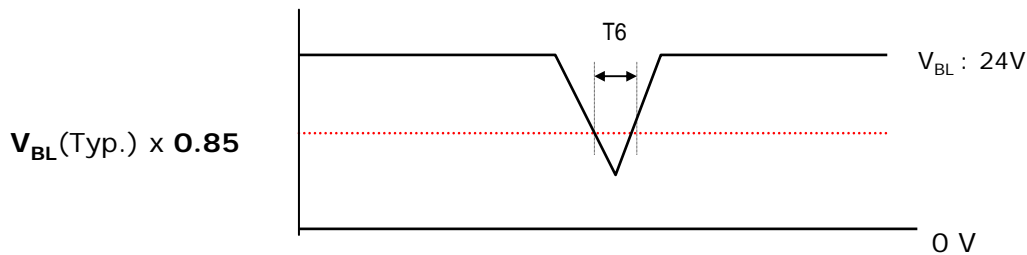

Table 11. Power Sequence for Inverter

Parameter	Values			Units	Remarks
	Min	Typ	Max		
T1	20	-	-	ms	1
T2	500	-	-	ms	
T3	200	-	-	ms	
T4	0	-	-	ms	3, 4
T5	10	-	-	ms	
T6	-	-	10	ms	$V_{BL}(Typ) \times 0.85$
T7	1000	-	-	ms	

- Note :**
1. T1 describes rising time of 0V to 24V and is not applied at restarting time.
 2. When V_{BL} (24V) is supplied always, there is no reliability problem.
 3. T4(max) is less than T2.
 4. In T7 section, $E_{xt}V_{BR-B}$ should be duty 100% and V_{BR-A} is recommended 3.3V.

Product Specification
4. Optical Specification

Optical characteristics are determined after the unit has been 'ON' for 30min in a dark environment at $25 \pm 2^\circ\text{C}$. The values specified are at an approximate distance 50cm from the LCD surface at a viewing angle of Φ and θ equal to 0° .

It is presented additional information concerning the measurement equipment and method in FIG. 1.

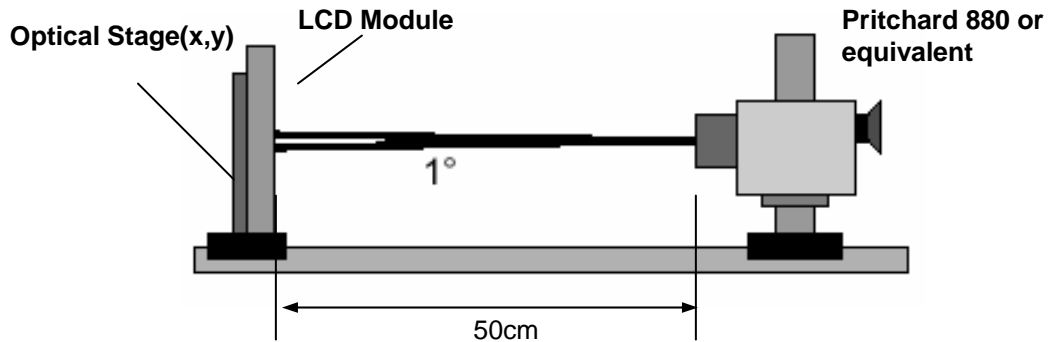
FIG. 1 Optical Characteristic Measurement Equipment and Method
Table 11. OPTICAL CHARACTERISTICS
 $T_a = 25 \pm 2^\circ\text{C}$, $V_{\text{LCD}} = 12.0\text{V}$, $f_v = 60\text{Hz}$, $D_{\text{clk}} = 72\text{MHz}$, $V_{\text{br-A}} = 1.6\text{V}$, $\text{ExtVbr} = 100\%$

Parameter	Symbol	Value			Unit	Note	
		Min	Typ	Max			
Contrast Ratio	CR	500	700			1	
Surface Luminance, white	L_{WH}	400	500		cd/m^2	2	
Luminance Variation	δ_{WHITE} 5P			1.3		3	
Response Time	Rise Time	T_{rR}	-	8	12	ms	4
	Decay Time	T_{rD}	-	9	13		
Color Coordinates [CIE1931]	RED	R_x	Typ -0.03	0.636	Typ +0.03		
		R_y		0.342			
	GREEN	G_x		0.280			
		G_y		0.605			
	BLUE	B_x		0.146			
		B_y		0.064			
	WHITE	W_x		0.272			
	W_y	0.278					
Viewing Angle (CR>10)							
	x axis, right($\phi=0^\circ$)	θ_r	85	89	-	degree	5
	x axis, left ($\phi=180^\circ$)	θ_l	85	89	-		
	y axis, up ($\phi=90^\circ$)	θ_u	85	89	-		
	y axis, down ($\phi=270^\circ$)	θ_d	85	89	-		
Gray Scale						6	

Product Specification

Notes 1. Contrast Ratio(CR) is defined mathematically as :

$$\text{Contrast Ratio} = \frac{\text{Surface Luminance with all white pixels}}{\text{Surface Luminance with all black pixels}}$$

It is measured at the center point(1).

2. Surface luminance is luminance value at the center point across the LCD surface 50cm from the surface with all pixels displaying white.
For more information, see FIG 2.
3. The variation in surface luminance , δ WHITE is defined as :

$$\delta \text{ WHITE}(5P) = \text{Maximum}(L_{on1}, L_{on2}, L_{on3}, \dots, L_{on5}) / \text{Minimum}(L_{on1}, L_{on2}, L_{on3}, \dots, L_{on5})$$
 Where L_{on1} to L_{on5} are the luminance with all pixels displaying white at 5 locations .
For more information, see FIG 2.
4. Response time is the time required for the display to transition from black to white (Rise Time, Tr_R) and from white to black (Decay Time, Tr_D).
For additional information, see FIG 3.
5. Viewing angle is the angle at which the contrast ratio is greater than 10. The angles are determined for the horizontal or x axis and the vertical or y axis with respect to the z axis which is normal to the LCD surface. For more information, see FIG 4.
6. Gray scale specification
Gamma Value is approximately 2.2.
For more information, see Table 12.

Table 12. GRAY SCALE SPECIFICATION

Gray Level	Luminance [%] (Typ)
L0	0.14
L15	0.32
L31	1.05
L47	2.55
L63	4.98
L79	8.64
L95	13.3
L111	18.6
L127	24.4
L143	31.1
L159	39.2
L175	47.9
L191	57.3
L207	67.6
L223	78.5
L239	89.0
L255	100.0

Product Specification

Measuring point for surface luminance & measuring point for luminance variation

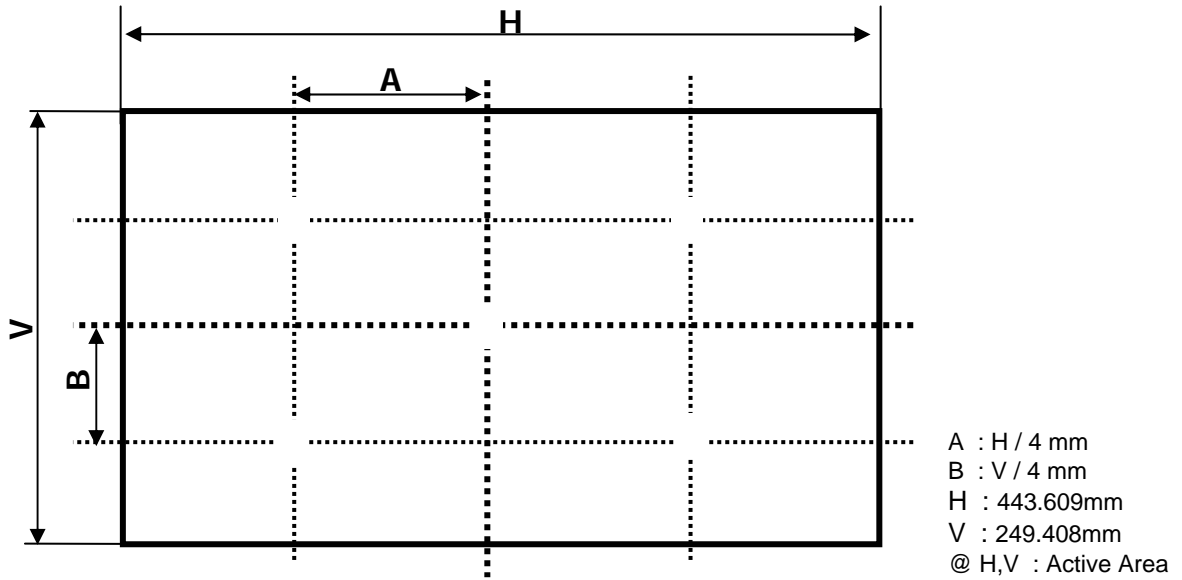

FIG. 2 Measure Point for Luminance

The response time is defined as the following figure and shall be measured by switching the input signal for Black to White and White to Black.

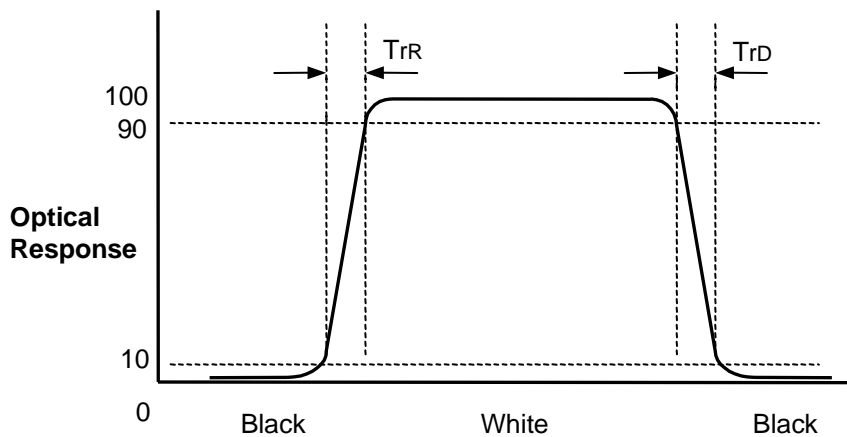

FIG. 3 Response Time

Product Specification

Dimension of viewing angle range

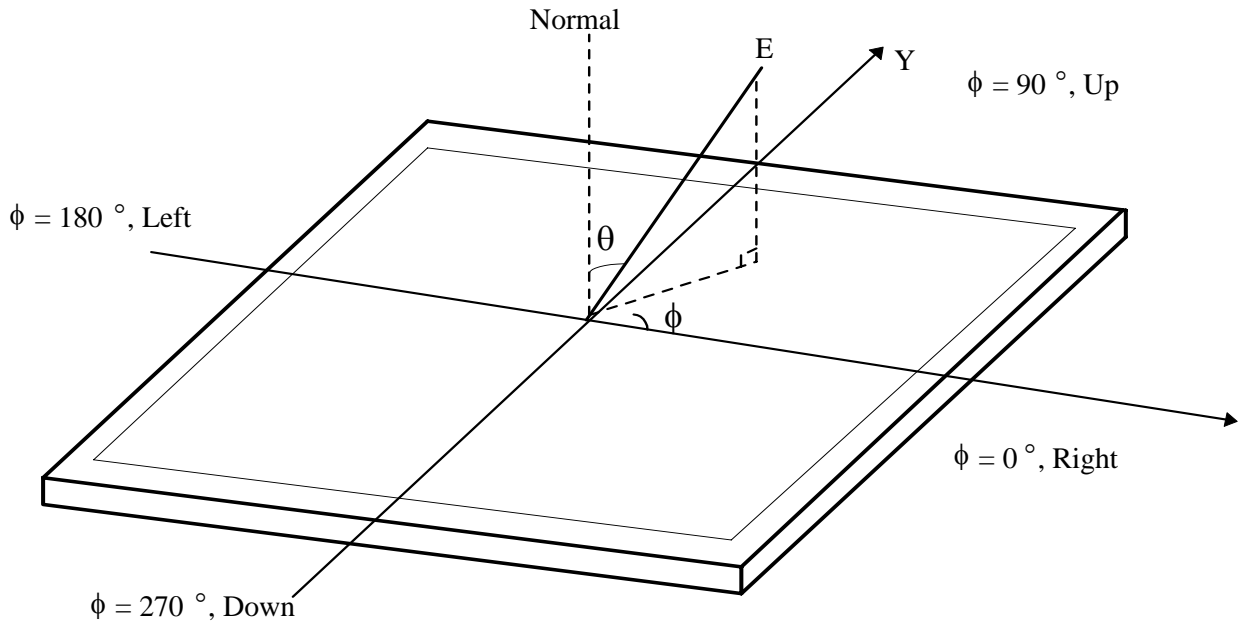

FIG. 4 Viewing angle

Product Specification

5. Mechanical Characteristics

The following items provide general mechanical characteristics. In addition the figures in the next page are detailed mechanical drawing of the LCD module.

Table 13. MECHANICAL CHARACTERISTICS

Outline Dimension	Horizontal	472.0mm
	Vertical	275.0mm
	Depth	38.0mm
Bezel Area	Horizontal	448.0mm
	Vertical	253.8mm
Active Display Area	Horizontal	443.609mm
	Vertical	249.408mm
Weight	(Typ.) 2,800 (g), (Max.) 3,000(g)	
Surface Treatment	Hard coating(3H) Anti-glare treatment of the front polarizer	

Note : Please refer to a mechanic drawing in terms of tolerance at the next page.

Product Specification

<FRONT VIEW>

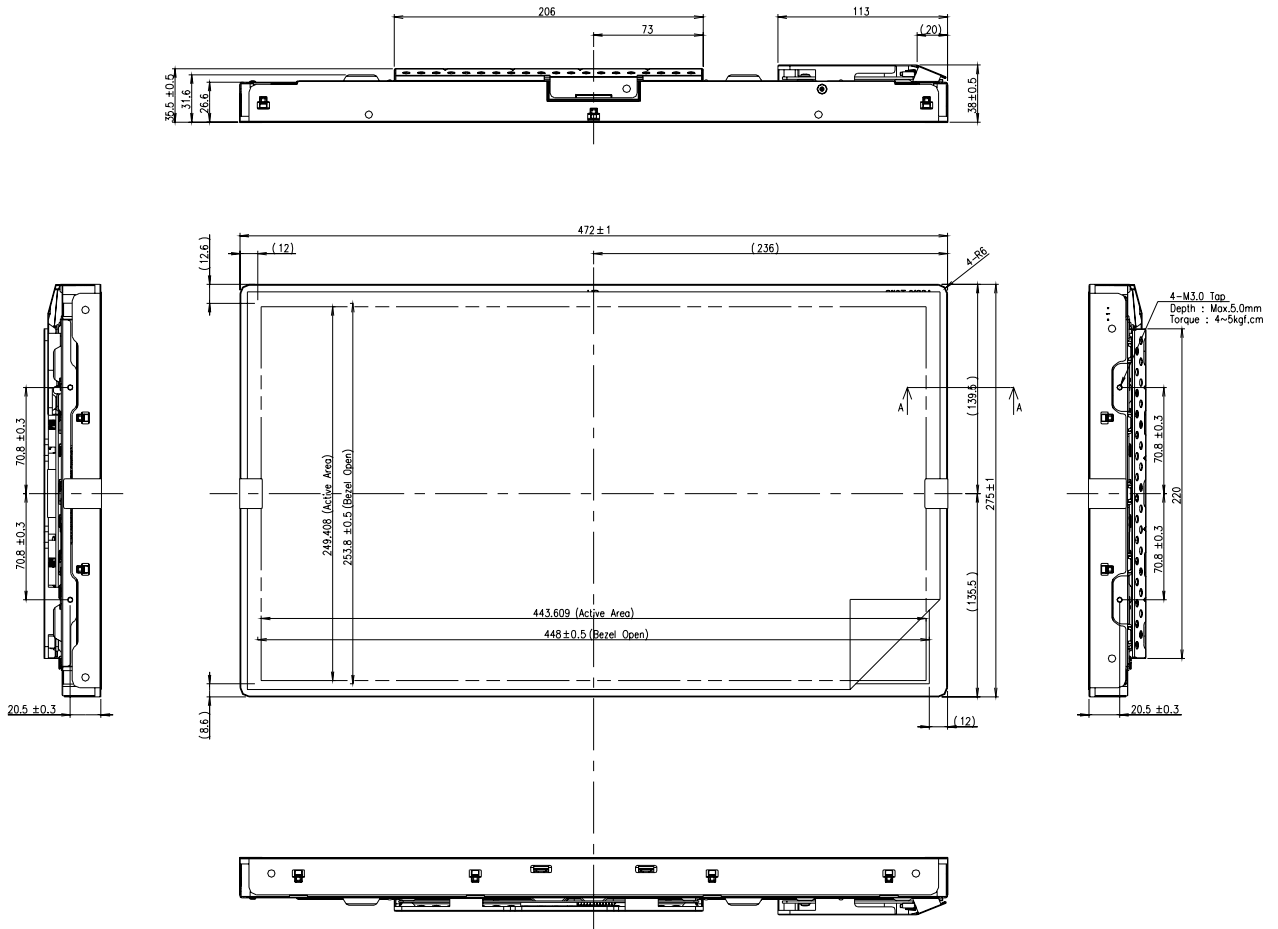

NOTES

1. UNSPECIFIED DIMENSIONAL TOLERANCES TO BE $\pm 0.5\text{mm}$.
2. GAP BETWEEN TOP CASE AND GLASS IS $0.3(+0.5/-0.3)$
3. MAXIMUM ALLOWABLE DEPTH OF REAR SIDE USER MOUNT HOLE IS 5.0mm
4. TILT AND A PARTIAL DISPOSITION TOLERANCE OF DISPLAY AREA ARE AS FOLLOW.
 - 1) X-DIRECTION : |A-B| < 1.4mm
 - 2) Y-DIRECTION : |C-D| < 1.4mm

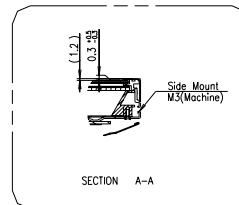
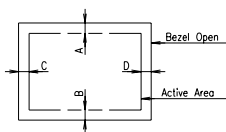

Product Specification

<REAR VIEW>

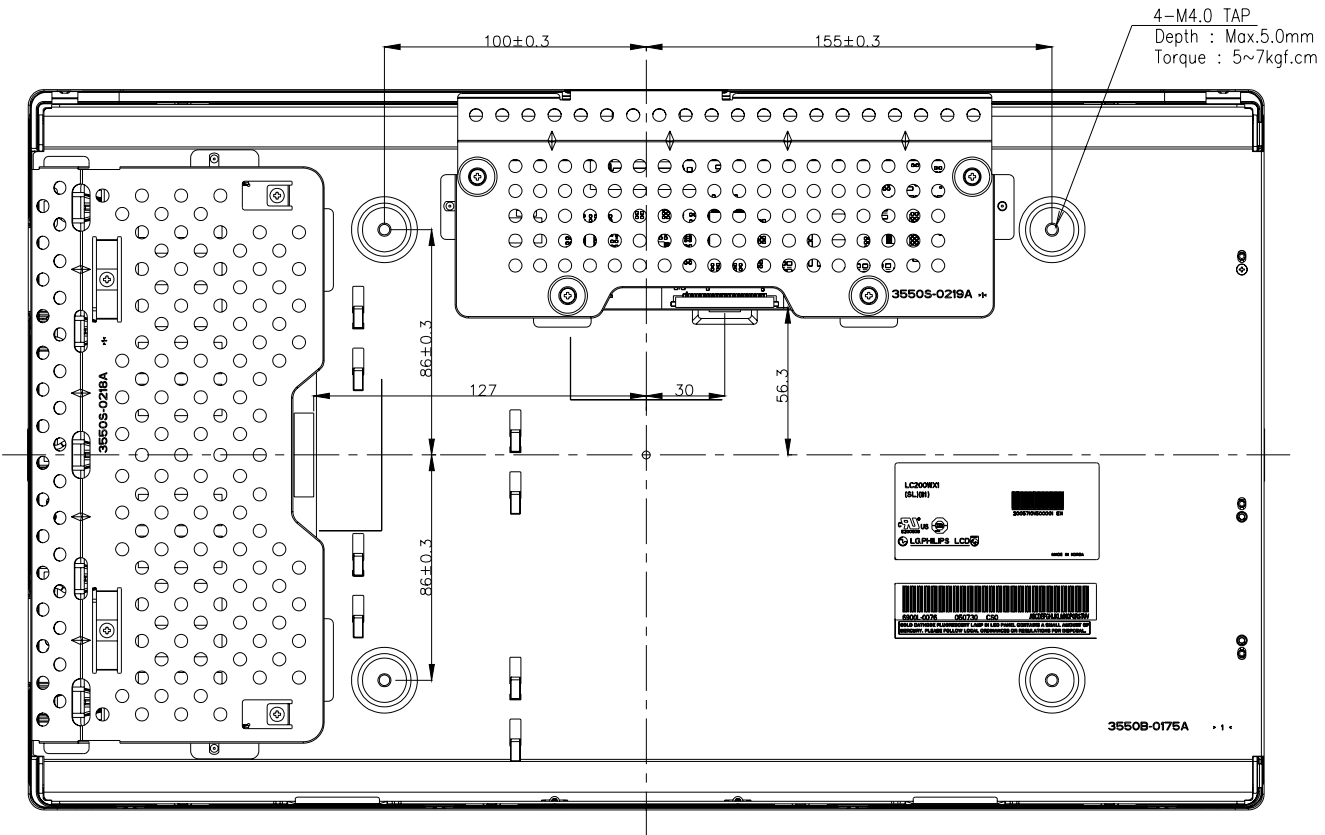

Product Specification

6. Reliability**Table 14. ENVIRONMENT TEST CONDITION**

No.	Test Item	Condition
1	High temperature storage test	Ta= 60°C 240h
2	Low temperature storage test	Ta= -20°C 240h
3	High temperature operation test	Ta= 50°C 50%RH 240h
4	Low temperature operation test	Ta= 0°C 240h
5	Vibration test (non-operating)	Wave form : random Vibration level : 1.0G RMS Bandwidth : 10-500Hz Duration : X,Y,Z, 10 min One time each direction
6	Shock test (non-operating)	Shock level : 100G Waveform : half sine wave, 2ms Direction : ± X, ± Y, ± Z One time each direction
7	Humidity condition Operation	Ta= 40 °C, 90%RH
8	Altitude operating storage / shipment	0 - 14,000 feet(4267.2m) 0 - 40,000 feet(12192m)

Product Specification

7. International standards

7-1. Safety

- a) UL 60950, Third Edition, Underwriters Laboratories, Inc., Dated Dec. 11, 2000.
Standard for Safety of Information Technology Equipment, Including Electrical Business Equipment.
- b) CAN/CSA C22.2, No. 60950, Third Edition, Canadian Standards Association, Dec. 1, 2000.
Standard for Safety of Information Technology Equipment, Including Electrical Business Equipment.
- c) EN 60950 : 2000, Third Edition
IEC 60950 : 1999, Third Edition
European Committee for Electrotechnical Standardization(CENELEC)
EUROPEAN STANDARD for Safety of Information Technology Equipment Including Electrical Business Equipment.

7-2. EMC

- a) ANSI C63.4 "Methods of Measurement of Radio-Noise Emissions from Low-Voltage Electrical and Electrical Equipment in the Range of 9kHz to 40GHz. "American National Standards Institute(ANSI), 1992
- b) C.I.S.P.R "Limits and Methods of Measurement of Radio Interface Characteristics of Information Technology Equipment." International Special Committee on Radio Interference.
- c) EN 55022 "Limits and Methods of Measurement of Radio Interface Characteristics of Information Technology Equipment." European Committee for Electrotechnical Standardization.(CENELEC), 1998 (Including A1: 2000)

Product Specification

8. Packing

8-1. Designation of Lot Mark

a) Lot Mark

A	B	C	D	E	F	G	H	I	J	K	L	M
---	---	---	---	---	---	---	---	---	---	---	---	---

A,B,C : SIZE(INCH)

E : MONTH

G : ASSEMBLY CODE

D : YEAR

F : FACTORY CODE

H ~ M : SERIAL NO.

Note

1. YEAR

Year	2001	2002	2003	2004	2005	2006	2007	2008	2009	2010
Mark	1	2	3	4	5	6	7	8	9	0

2. MONTH

Month	Jan	Feb	Mar	Apr	May	Jun	Jul	Aug	Sep	Oct	Nov	Dec
Mark	1	2	3	4	5	6	7	8	9	A	B	C

3. FACTORY CODE

Factory Code	LPL Gumi	LPL Nanjing	HEESUNG
Mark	K	C	D

4. SERIAL NO.

Mark	100001~199999, 200001~299999, 300001~399999, ..., A00001~A99999,, Z00001~Z99999
------	---

b) Location of Lot Mark

Serial No. is printed on the label. The label is attached to the backside of the LCD module.
This is subject to change without prior notice.

8-2. Packing Form

a) Package quantity in one box : 4 pcs

b) Box Size : 530mm X 310mm X 327mm

Product Specification

9. Precautions

Please pay attention to the followings when you use this TFT LCD module.

9-1. Mounting Precautions

- (1) You must mount a module using holes arranged in four corners or four sides.
- (2) You should consider the mounting structure so that uneven force (ex. Twisted stress) is not applied to the module. And the case on which a module is mounted should have sufficient strength so that external force is not transmitted directly to the module.
- (3) Please attach the surface transparent protective plate to the surface in order to protect the polarizer. Transparent protective plate should have sufficient strength in order to resist external force.
- (4) You should adopt radiation structure to satisfy the temperature specification.
- (5) Acetic acid type and chlorine type materials for the cover case are not desirable because the former generates corrosive gas of attacking the polarizer at high temperature and the latter causes circuit break by electro-chemical reaction.
- (6) Do not touch, push or rub the exposed polarizers with glass, tweezers or anything harder than HB pencil lead. And please do not rub with dust clothes with chemical treatment. Do not touch the surface of polarizer for bare hand or greasy cloth.(Some cosmetics are detrimental to the polarizer.)
- (7) When the surface becomes dusty, please wipe gently with absorbent cotton or other soft materials like chamois soaks with petroleum benzene. Normal-hexane is recommended for cleaning the adhesives used to attach front / rear polarizers. Do not use acetone, toluene and alcohol because they cause chemical damage to the polarizer.
- (8) Wipe off saliva or water drops as soon as possible. Their long time contact with polarizer causes deformations and color fading.
- (9) Do not open the case because inside circuits do not have sufficient strength.

9-2. Operating Precautions

- (1) The spike noise causes the mis-operation of circuits. It should be lower than following voltage :
 $V = \pm 200\text{mV}$ (Over and under shoot voltage)
- (2) Response time depends on the temperature.(In lower temperature, it becomes longer.)
- (3) Brightness depends on the temperature. (In lower temperature, it becomes lower.)
And in lower temperature, response time(required time that brightness is stable after turned on) becomes longer.
- (4) Be careful for condensation at sudden temperature change. Condensation makes damage to polarizer or electrical contacted parts. And after fading condensation, smear or spot will occur.
- (5) When fixed patterns are displayed for a long time, remnant image is likely to occur.
- (6) Module has high frequency circuits. Sufficient suppression to the electromagnetic interference shall be done by system manufacturers. Grounding and shielding methods may be important to minimized the interference.
- (7) Please do not give any mechanical and/or acoustical impact to LCM. Otherwise, LCM can't be operated its full characteristics perfectly.
- (8) A screw which is fastened up the steels should be a machine screw.
(if not, it causes metallic foreign material and deal LCM a fatal blow)
- (9) Please do not set LCD on its edge.

Product Specification

9-3. Electrostatic Discharge Control

Since a module is composed of electronic circuits, it is not strong to electrostatic discharge. Make certain that treatment persons are connected to ground through wrist band etc. And don't touch interface pin directly.

9-4. Precautions for Strong Light Exposure

Strong light exposure causes degradation of polarizer and color filter.

9-5. Storage

When storing modules as spares for a long time, the following precautions are necessary.

- (1) Store them in a dark place. Do not expose the module to sunlight or fluorescent light. Keep the temperature between 5°C and 35°C at normal humidity.
- (2) The polarizer surface should not come in contact with any other object.
It is recommended that they be stored in the container in which they were shipped.

9-6. Handling Precautions for Protection Film

- (1) The protection film is attached to the bezel with a small masking tape.
When the protection film is peeled off, static electricity is generated between the film and polarizer.
This should be peeled off slowly and carefully by people who are electrically grounded and with well ion-blown equipment or in such a condition, etc.
- (2) When the module with protection film attached is stored for a long time, sometimes there remains a very small amount of glue still on the bezel after the protection film is peeled off.
- (3) You can remove the glue easily. When the glue remains on the bezel surface or its vestige is recognized, please wipe them off with absorbent cotton waste or other soft material like chamois soaked with normal-hexane.