



LC216EXN

Product Specification

SPECIFICATION FOR APPROVAL

() Preliminary Specification

(●) Final Specification

Title	21.6" WXGA TFT LCD
-------	--------------------

BUYER	
MODEL	

SUPPLIER	LG Display Co., Ltd.
*MODEL	LC216EXN
SUFFIX	SDA2(ROHS verified)

*When you obtain standard approval,
please use the above model name without suffix

APPROVED BY	SIGNATURE DATE
/	
/	
/	

Please return 1 copy for your confirmation with your signature and comments.

APPROVED BY	SIGNATURE DATE
H. S. SONG /Team Leader	
REVIEWED BY	
H. S. CHOI / Project Leader	
PREPARED BY	
S. J. BAE / Engineer	

TV Product Development Dept.
LG Display Co., Ltd.

LC216EXN

Product Specification

CONTENTS

Number	ITEM	Page
	COVER	1
	CONTENTS	2
	RECORD OF REVISIONS	3
1	GENERAL DESCRIPTION	4
2	ABSOLUTE MAXIMUM RATINGS	5
3	ELECTRICAL SPECIFICATIONS	6
3-1	ELECTRICAL CHARACTERISTICS	6
3-2	INTERFACE CONNECTIONS	8
3-3	SIGNAL TIMING SPECIFICATIONS	10
3-4	SIGNAL TIMING WAVEFORMS	11
3-5	COLOR DATA REFERENCE	14
3-6	POWER SEQUENCE	15
4	OPTICAL SPECIFICATIONS	17
5	MECHANICAL CHARACTERISTICS	21
6	RELIABILITY	24
7	INTERNATIONAL STANDARDS	25
7-1	SAFETY	25
7-2	EMC	25
7-3	Environment	25
8	PACKING	26
8-1	INFORMATION OF LCM LABEL	26
8-2	PACKING FORM	26
9	PRECAUTIONS	27
9-1	MOUNTING PRECAUTIONS	27
9-2	OPERATING PRECAUTIONS	27
9-3	ELECTROSTATIC DISCHARGE CONTROL	28
9-4	PRECAUTIONS FOR STRONG LIGHT EXPOSURE	28
9-5	STORAGE	28
9-6	HANDLING PRECAUTIONS FOR PROTECTION FILM	28

Ver 1.0

2/37

LC216EXN

Product Specification

RECORD OF REVISIONS

Revision No.	Revision Date	Page	Description
0.1	July 31, 2010	-	Preliminary Specification (First Draft)
0.2	Aug. 19, 2010	7	Change the min value of ExtVBR-B.
		4.6	Change the logic power consumption.
0.3	Sept. 29, 2010	4,7	Change the electrical characteristics.
		17	Change the color coordinates.
		22	Change the mechanical drawing.
		15	Change the min value of T4, T8 in power sequence.
		28	Revise the contents about storage.
1.0	Oct. 11, 2010	37	Add appendix about drop test [packing condition]
		-	Final CAS.

Product Specification

1. General Description

The LC216EXN is a Color Active Matrix Liquid Crystal Display with an integral Light Emitting Diode (LED) backlight system. The matrix employs a-Si Thin Film Transistor as the active element.

It is a transmissive display type which is operating in the normally black mode. It has a 21.6 inch diagonally measured active display area with WXGA resolution (768 vertical by 1366 horizontal pixel array).

Each pixel is divided into Red, Green and Blue sub-pixels or dots which are arrayed in vertical stripes.

Gray scale or the luminance of the sub-pixel color is determined with a 8-bit gray scale signal for each dot, thus presenting a palette of more than 16.7M(6bit + A-FRC) colors.

It has been designed to apply the 8-bit 1-port LVDS interface.

It is intended to support LCD TV, PCTV where high brightness, super wide viewing angle, high color gamut, high color depth and fast response time are important.

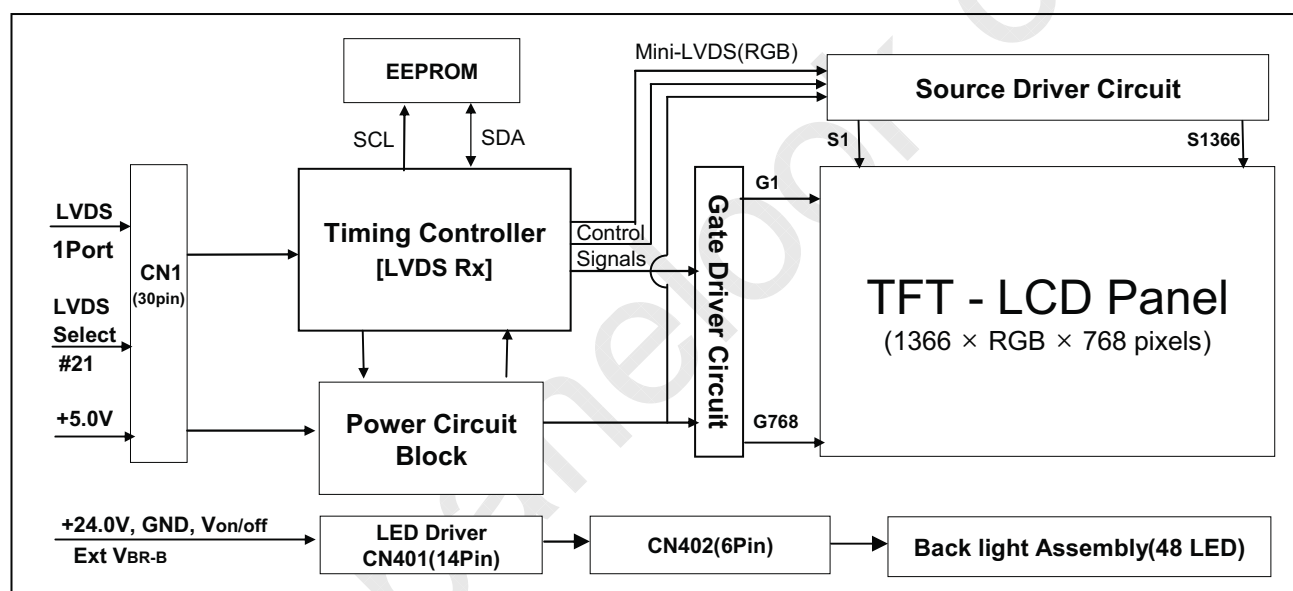

General Features

Active Screen Size	21.6 inches(547.7mm) diagonal
Outline Dimension	501(H) × 297(V) × 12.7(D) (Typ.)
Pixel Pitch	0.1165 mm x 0.3495 mm
Pixel Format	1366 horiz. by 768 vert. Pixels, RGB stripe arrangement
Color Depth	8-bit(D), 16.7M colors
Luminance, White	300 cd/m ² (Center 1point) (Typ.)
Viewing Angle (CR>10)	Viewing angle free (R/L 178(Min.), U/D 178(Min.))
Power Consumption	Total 23.65W (Typ.) (Logic=3.15W, LED Driver=20.5W EXT VBR-B=100%)
Weight	1,420 (Typ.)
Display Mode	Transmissive mode, Normally black
Surface Treatment	Hard coating(3H), Anti-glare treatment of the front polarizer (Haze 13%)

LC216EXN

Product Specification

2. Absolute Maximum Ratings

The following items are maximum values which, if exceeded, may cause faulty operation or damage to the LCD module.

Table 1. ABSOLUTE MAXIMUM RATINGS

Parameter		Symbol	Value		Unit	Note
			Min	Max		
Power Input Voltage	LCD Circuit	VLCD	-0.3	+6.0	VDC	1
	Driver	VBL	-0.3	+ 27.0	VDC	
Driver Control Voltage	ON/OFF	V _{OFF} / V _{ON}	-0.3	+5.5	VDC	
	Brightness	VBR	0.0	+5.5	VDC	
T-Con Option Selection Voltage		VLOGIC	-0.3	+4.0	VDC	
Operating Temperature		T _{OP}	0	+50	°C	
Storage Temperature		T _{ST}	-20	+60	°C	
Panel Front Temperature		T _{SUR}	-	+68	°C	4
Operating Ambient Humidity		H _{OP}	10	90	%RH	2,3
Storage Humidity		H _{ST}	10	90	%RH	

Note 1. Ambient temperature condition ($T_a = 25 \pm 2 \text{ }^\circ\text{C}$)

2. Temperature and relative humidity range are shown in the figure below.

Wet bulb temperature should be Max 39°C, and no condensation of water.

3. Gravity mura can be guaranteed below 40°C condition.

4. The maximum operating temperatures is based on the test condition that the surface temperature of display area is less than or equal to 68°C with LCD module alone in a temperature controlled chamber. Thermal management should be considered in final product design to prevent the surface temperature of display area from being over 68°C. The range of operating temperature may degraded in case of improper thermal management in final product design.

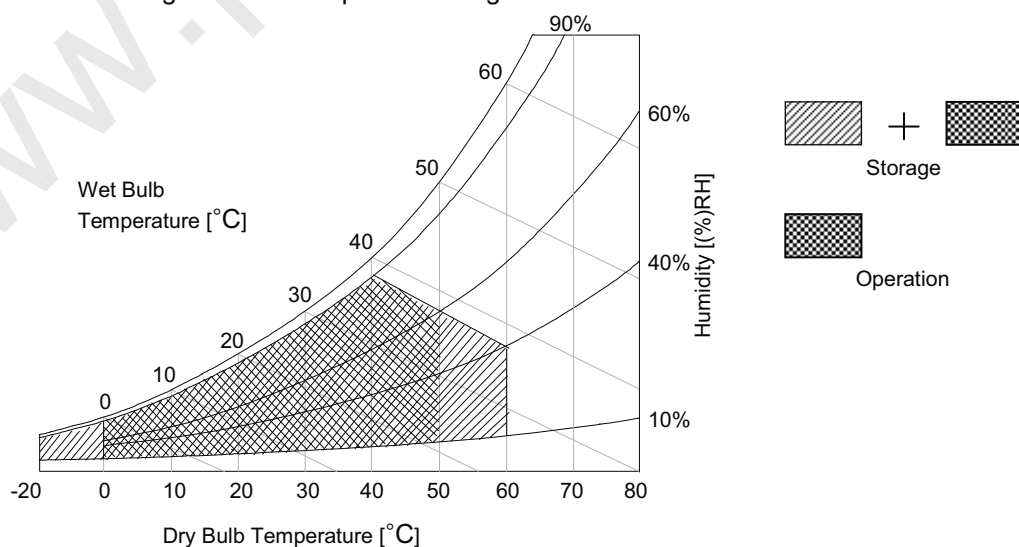

Ver 1.0

5/37

Product Specification

3. Electrical Specifications

3-1. Electrical Characteristics

It requires two power inputs. One is employed to power for the LCD circuit. The other is used for the LED backlight and LED Driver circuit.

Table 2. ELECTRICAL CHARACTERISTICS

Parameter	Symbol	Value			Unit	Note
		Min	Typ	Max		
Circuit :						
Power Input Voltage	V _{LCD}	4.5	5.0	5.5	VDC	
Power Input Current	I _{LCD}	-	630	819	mA	1
		-	780	1014	mA	2
Power Consumption	P _{LCD}	-	3.15	4.1	Watt	1
Rush current	I _{RUSH}	-	-	3.0	A	3

- Notes : 1. The specified current and power consumption are under the $V_{LCD}=5.0V$, $25 \pm 2^{\circ}C$, $f_V=60Hz$ condition, and mosaic pattern(8 x 6) is displayed and f_V is the frame frequency.
 2. The current is specified at the maximum current pattern.
 3. The duration of rush current is about 2ms and rising time of power input is 0.5ms (min.).

White : 255Gray
 Black : 0Gray

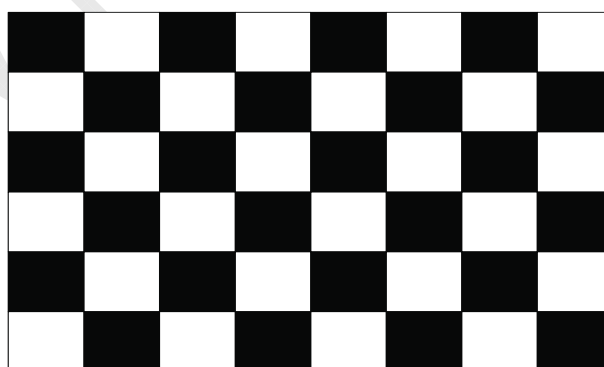

Mosaic Pattern(8 x 6)

LC216EXN

Product Specification

Table 3. ELECTRICAL CHARACTERISTICS (Continue)

Parameter		Symbol	Values			Unit	Notes	
			Min	Typ	Max			
LED Driver :								
Power Supply Input Voltage		VBL	22.8	24.0	25.2	Vdc	1	
Power Supply Input Current		IBL_A	-	0.854	0.90	A	1	
Power Supply Input Current (In-Rush)		Irush	-	-	1.8	A	VBL = 22.8V Ext VBR-B = 100%	
Power Consumption		PBL	-	20.5	21.76	W	1	
Input Voltage for Control System Signals	On/Off	On	V on	2.5	-	5.0	Vdc	
		Off	V off	-0.3	0.0	0.7	Vdc	
	Brightness Adjust		ExtVBR-B	1	-	100	%	On Duty
	PWM Frequency for NTSC & PAL		PAL		100		Hz	4
			NTSC		120		Hz	4
	Pulse Duty Level (PWM)		High Level	2.5	-	5.0	Vdc	HIGH : on duty LOW : off duty
Low Level			0.0	-	0.7	Vdc		
LED :								
Life Time			30,000			Hrs	3	

Notes :

- Electrical characteristics are determined after the unit has been 'ON' and stable for approximately 60 minutes at $25\pm 2^{\circ}\text{C}$. The specified current and power consumption are under the typical supply Input voltage 24V and VBR (ExtVBR-B : 100%), it is total power consumption.
- Electrical characteristics are determined within 30 minutes at $25\pm 2^{\circ}\text{C}$. The specified currents are under the typical supply Input voltage 24V.
- The life time is determined as the time which luminance of the LED is 50% compared to that of initial value at the typical LED current (ExtVBR-B : 100%) on condition of continuous operating in LCM state at $25\pm 2^{\circ}\text{C}$.
- LGD recommend that the PWM freq. is synchronized with two time harmonic of Vsync signal of system. Though PWM frequency is over 120Hz (max 252Hz), function of LED Driver is not affected.
- The duration of rush current is about 200ms.
- Even though inrush current is over the specified value, there is no problem if I²T spec of fuse is satisfied.

LC216EXN

Product Specification

3-2. Interface Connections

This LCD module employs two kinds of interface connection, a 30-pin connector is used for the module electronics and 14-pin connector is used for the integral backlight system.

3-2-1. LCD Module

- LCD Connector(CN1) : KDF71G-30S-1H(Hirose) or Compatible.
- Mating Connector : FI-X30C2L (Manufactured by JAE) or Equivalent

Table 4. MODULE CONNECTOR(CN1) PIN CONFIGURATION

Pin No.	Symbol	Description	Note
1	NC	Reserved	4
2	SCL	I2C Interface Clock	
3	SDA	I2C Interface Data	
4	GND	Ground	
5	RX0-	LVDS Receiver Signal(-)	
6	RX0+	LVDS Receiver Signal(-)	
7	GND	Ground	
8	RX1-	LVDS Receiver Signal(-)	
9	RX1+	LVDS Receiver Signal(-)	
10	GND	Ground	
11	RX2-	LVDS Receiver Signal(-)	
12	RX2+	LVDS Receiver Signal(-)	
13	GND	Ground	
14	RXCLK-	LVDS Receiver Signal(-)	
15	RXCLK+	LVDS Receiver Signal(-)	
16	GND	Ground	
17	RX3-	LVDS Receiver Signal(-)	
18	RX3+	LVDS Receiver Signal(-)	
19	GND	Ground	
20	Panel SEL	Panel Selection	
21	LVDS SEL	'H' or NC = VESA , 'L' =JEIDA	Appendix V
22	B-INT(WP)	Write Protection	
23	GND	Ground	
24	GND	Ground	
25	NC	NC (Open : Inside of Panel)	
26	VLCD	Power Supply +5.0V	
27	VLCD	Power Supply +5.0V	
28	VLCD	Power Supply +5.0V	
29	VLCD	Power Supply +5.0V	
30	VLCD	Power Supply +5.0V	

- Notes :
1. All GND (Ground) pins should be connected together to the LCD module's metal frame.
 2. All VLCD (Power input) pins should be connected together.
 3. All Input levels of LVDS signals are based on the EIA 644 Standard.
 4. Specific pin No. #1 is used for "No signal detection" of system signal interface.
It should be GND for NSB (No Signal Black) during the system interface signal is not.
If this pin is "H", LCD Module displays AGP (Auto Generation Pattern).

LC216EXN

Product Specification

3-2-2. Backlight Inverter

- LED Connector : SM14B-SRSS-TB (Manufactured by JST)
- Mating Connector : SHR-14V-S-B (With protrusions) or SHR-14V-S (Without protrusions)
(Manufactured by JST)

Table 5. LED DRIVER CONNECTOR PIN CONFIGURATION

Pin No	Symbol	Description	Note
1	VBL	Power Supply +24.0V	
2	VBL	Power Supply +24.0V	
3	VBL	Power Supply +24.0V	
4	VBL	Power Supply +24.0V	
5	VBL	Power Supply +24.0V	
6	GND	Backlight Ground	
7	GND	Backlight Ground	
8	GND	Backlight Ground	1
9	GND	Backlight Ground	
10	GND	Backlight Ground	
11	Status	LED Status	2
12	VON/OFF	Backlight ON/OFF control	
13	NC	No Connection	
14	EXTVBR-B	External PWM	3

- Notes : 1. GND should be connected to the LCD module's metal frame.
 2. Normal : Low (under 0.7V) / Abnormal : High (upper 3.0V)
 3. High : on duty / Low : off duty
 4. Each impedance of pin #12 and 14 is over 50[KΩ] and over 50[KΩ].

◆ Rear view of LCM

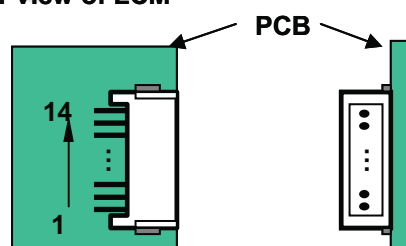

LC216EXN

Product Specification

3-3. Signal Timing Specifications

Table 6 shows the signal timing required at the input of the LVDS transmitter. All of the interface signal timings should be satisfied with the following specification for normal operation.

Table 6. TIMING TABLE (DE Only Mode)

ITEM		Symbol	Min	Typ	Max	Unit	Note
Horizontal	Display Period	t_{HV}	-	1366	-	tclk	
	Blank	t_{HB}	90	162	410	tclk	
	Total	t_{HP}	1456	1528	1776	tclk	
Vertical	Display Period	t_{VV}	-	768	-	tHP	
	Blank	t_{VB}	20 (126)	22 (180)	240 (295)	tHP	
	Total	t_{VP}	788 (894)	790 (948)	1008 (1063)	tHP	

ITEM		Symbol	Min	Typ	Max	Unit	Note
Frequency	DCLK	f_{CLK}	63.0	72.4	80.0	MHz	
	Horizontal	f_H	45	47.4	55	KHz	2
	Vertical	f_V	57 (47)	60 (50)	63 (53)	Hz	2 NTSC : 57~63Hz (PAL : 47~53Hz)

Note :

1. The input of HSYNC & VSYNC signal does not have an effect on normal operation (DE Only Mode). If you use spread spectrum of EMI, add some additional clock to minimum value for clock margin.
2. The performance of the electro-optical characteristics may be influenced by variance of the vertical refresh rate and the horizontal frequency

※ Timing should be set based on clock frequency.

Product Specification

3-4. Signal Timing Waveforms

3-4-1. LVDS Input Signal Timing Diagram

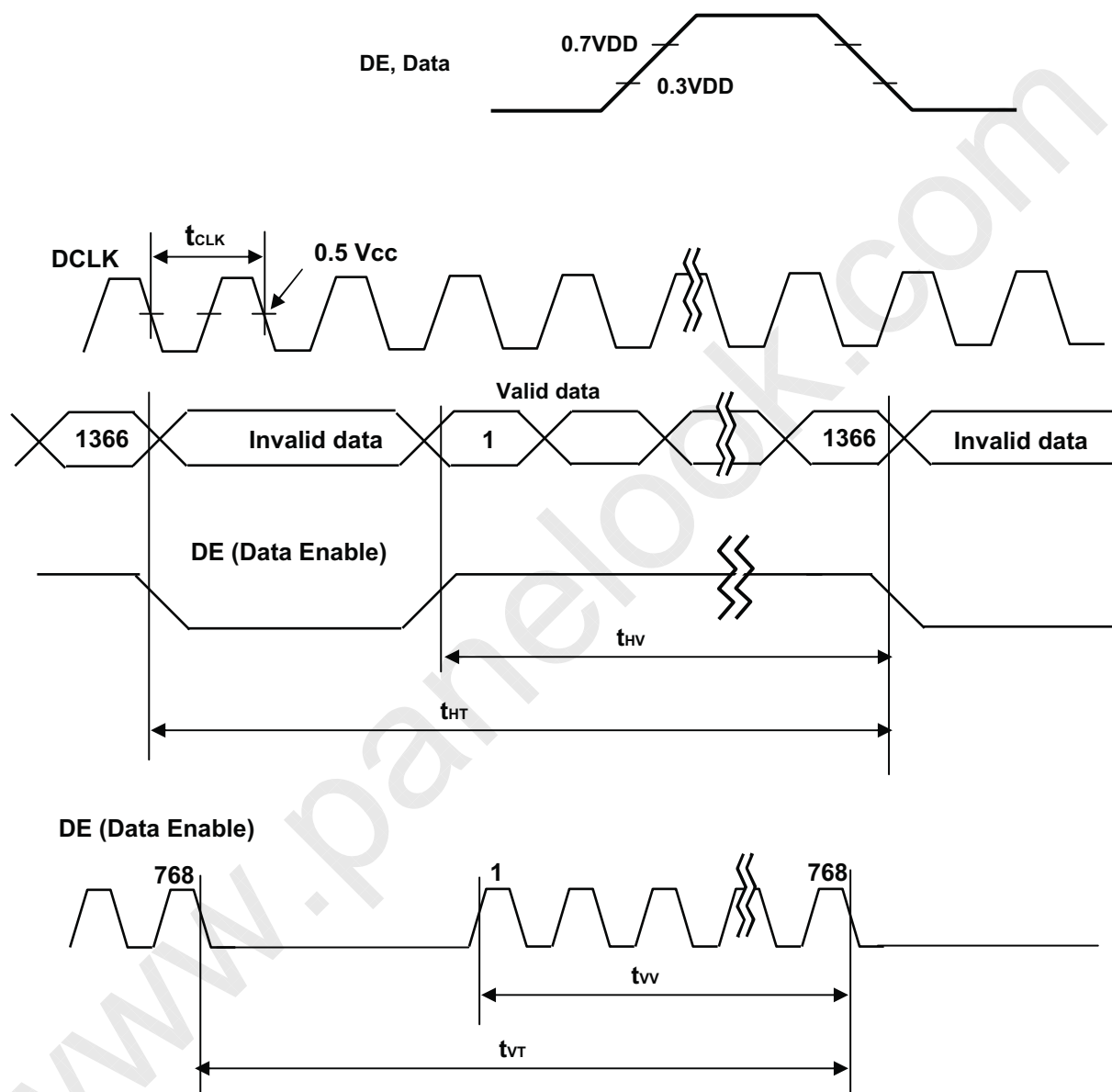

LC216EXN

Product Specification

3-4-2. LVDS Input Signal Characteristics

1) DC Specification

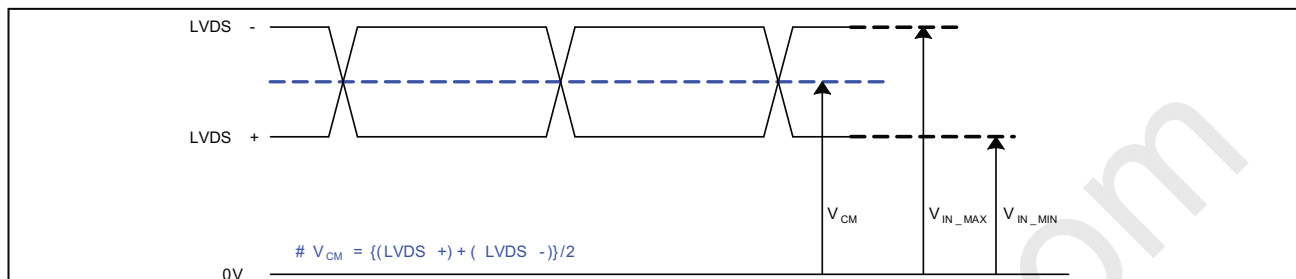

Description	Symbol	Min	Max	Unit	Note
LVDS Common mode Voltage	V_{CM}	1.0	1.5	V	-
LVDS Input Voltage Range	V_{IN}	0.7	1.8	V	-
Change in common mode Voltage	ΔV_{CM}		250	mV	-

2) AC Specification

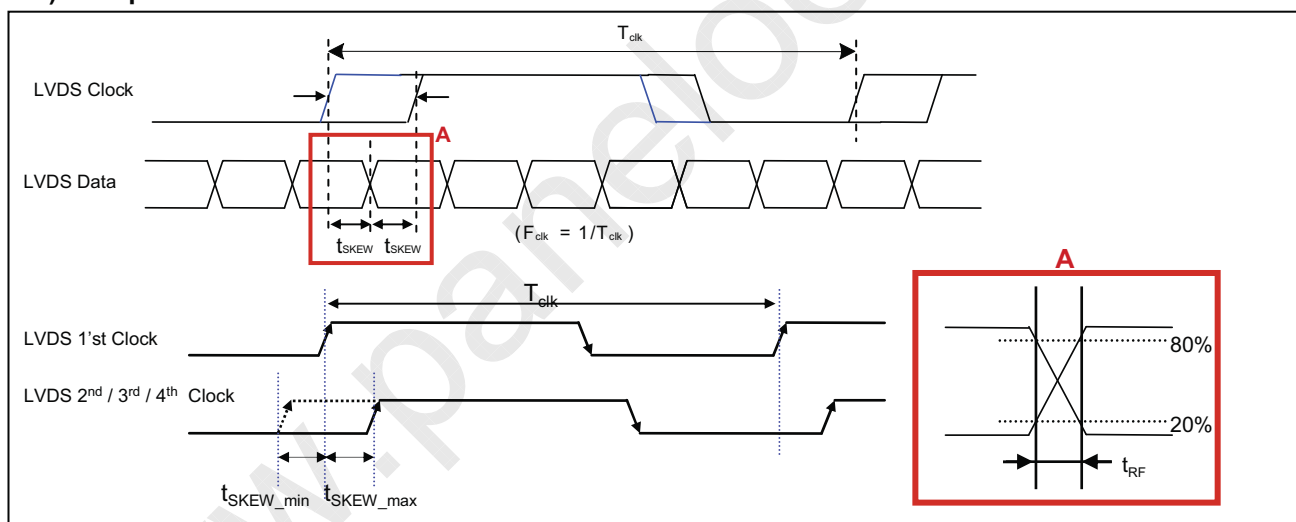

Description	Symbol	Min	Max	Unit	Note	
LVDS Differential Voltage	High Threshold	V_{TH}	100	300	mV	3
	Low Threshold	V_{TL}	-300	-100	mV	
LVDS Clock to Data Skew Margin	t_{SKEW}		$\lfloor (0.2 * T_{clk}) / 7 \rfloor$	ps	-	
LVDS Clock/DATA Rising/Falling time	t_{RF}	260	$(0.3 * T_{clk}) / 7$	ps	2	
Effective time of LVDS	t_{eff}	± 360		ps	-	
LVDS Clock to Clock Skew Margin (Even to Odd)	t_{SKEW_EO}		$1/7 * T_{clk}$	T_{clk}	-	

- Note
1. All Input levels of LVDS signals are based on the EIA 644 Standard.
 2. If t_{RF} isn't enough, t_{eff} should be meet the range.
 3. LVDS Differential Voltage is defined within t_{eff}

LC216EXN

Product Specification

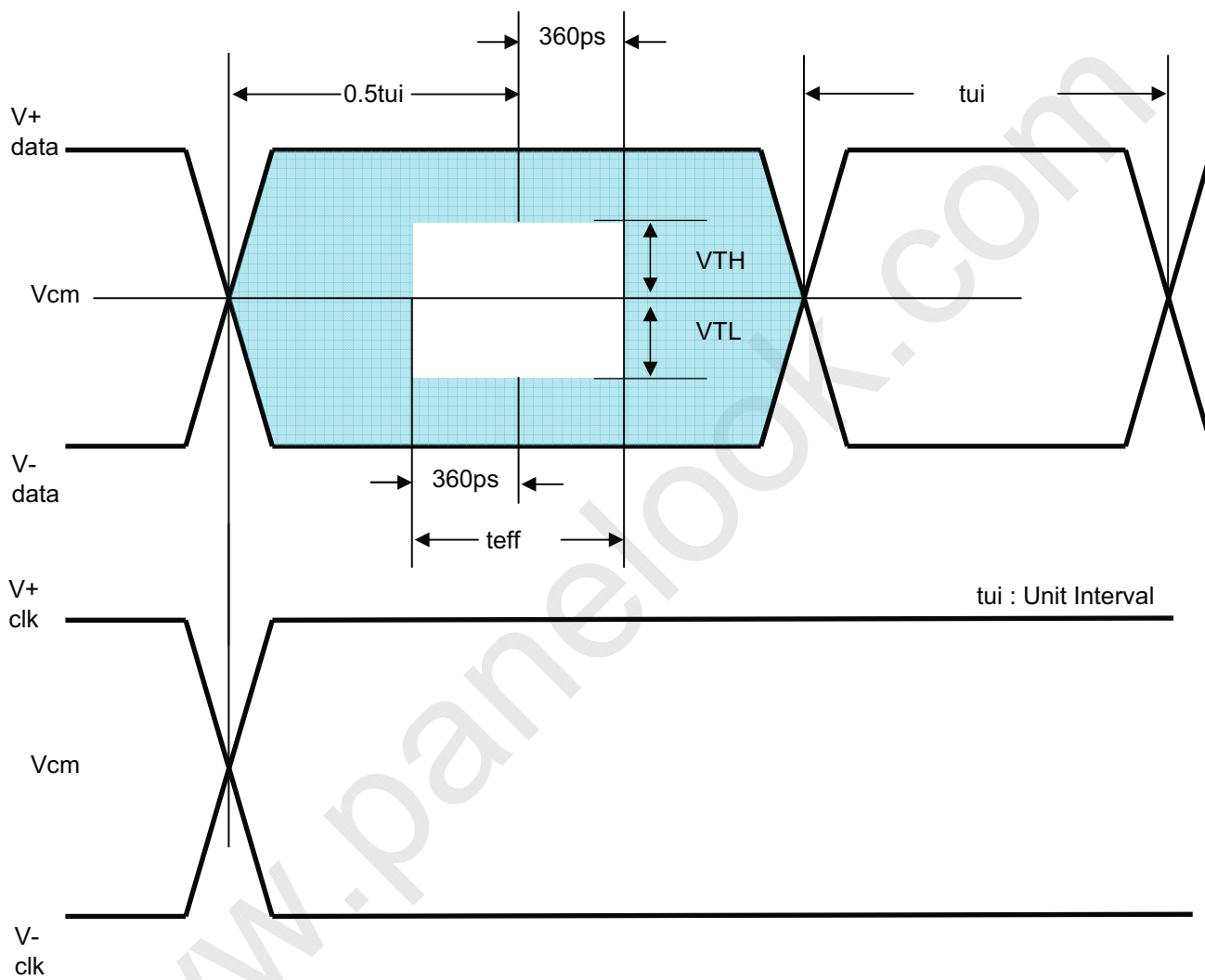

Product Specification

3-5. Color Data Reference

The brightness of each primary color (Red, Green, Blue) is based on the 8-bit gray scale data input for the color. The higher binary input, the brighter the color. Table 7 provides a reference for color versus data input.

Table 7. COLOR DATA REFERENCE

Color		Input Color Data																							
		RED								GREEN								BLUE							
		MSB				LSB				MSB				LSB				MSB				LSB			
		R7	R6	R5	R4	R3	R2	R1	R0	G7	G6	G5	G4	G3	G2	G1	G0	B7	B6	B5	B4	B3	B2	B1	B0
Basic Color	Black	0	0	0	0	0	0	0	0	0	0	0	0	0	0	0	0	0	0	0	0	0	0	0	0
	Red (255)	1	1	1	1	1	1	1	1	0	0	0	0	0	0	0	0	0	0	0	0	0	0	0	0
	Green (255)	0	0	0	0	0	0	0	0	1	1	1	1	1	1	1	1	0	0	0	0	0	0	0	0
	Blue (255)	0	0	0	0	0	0	0	0	0	0	0	0	0	0	0	0	1	1	1	1	1	1	1	1
	Cyan	0	0	0	0	0	0	0	0	1	1	1	1	1	1	1	1	1	1	1	1	1	1	1	1
	Magenta	1	1	1	1	1	1	1	1	0	0	0	0	0	0	0	0	1	1	1	1	1	1	1	1
	Yellow	1	1	1	1	1	1	1	1	1	1	1	1	1	1	1	1	0	0	0	0	0	0	0	0
	White	1	1	1	1	1	1	1	1	1	1	1	1	1	1	1	1	1	1	1	1	1	1	1	1
RED	RED (000) Dark	0	0	0	0	0	0	0	0	0	0	0	0	0	0	0	0	0	0	0	0	0	0	0	0
	RED (001)	0	0	0	0	0	0	0	1	0	0	0	0	0	0	0	0	0	0	0	0	0	0	0	0
							
	RED (254)	1	1	1	1	1	1	1	0	0	0	0	0	0	0	0	0	0	0	0	0	0	0	0	0
	RED (255)	1	1	1	1	1	1	1	1	0	0	0	0	0	0	0	0	0	0	0	0	0	0	0	0
GREEN	GREEN (000) Dark	0	0	0	0	0	0	0	0	0	0	0	0	0	0	0	0	0	0	0	0	0	0	0	0
	GREEN (001)	0	0	0	0	0	0	0	0	0	0	0	0	0	0	0	1	0	0	0	0	0	0	0	0
							
	GREEN (254)	0	0	0	0	0	0	0	0	1	1	1	1	1	1	1	0	0	0	0	0	0	0	0	0
	GREEN (255)	0	0	0	0	0	0	0	0	1	1	1	1	1	1	1	1	0	0	0	0	0	0	0	0
BLUE	BLUE (000) Dark	0	0	0	0	0	0	0	0	0	0	0	0	0	0	0	0	0	0	0	0	0	0	0	0
	BLUE (001)	0	0	0	0	0	0	0	0	0	0	0	0	0	0	0	0	0	0	0	0	0	0	0	1
							
	BLUE (254)	0	0	0	0	0	0	0	0	0	0	0	0	0	0	0	0	1	1	1	1	1	1	1	0
	BLUE (255)	0	0	0	0	0	0	0	0	0	0	0	0	0	0	0	0	1	1	1	1	1	1	1	1

Product Specification

3-6. Power Sequence

3-6-1. LCD Driving circuit

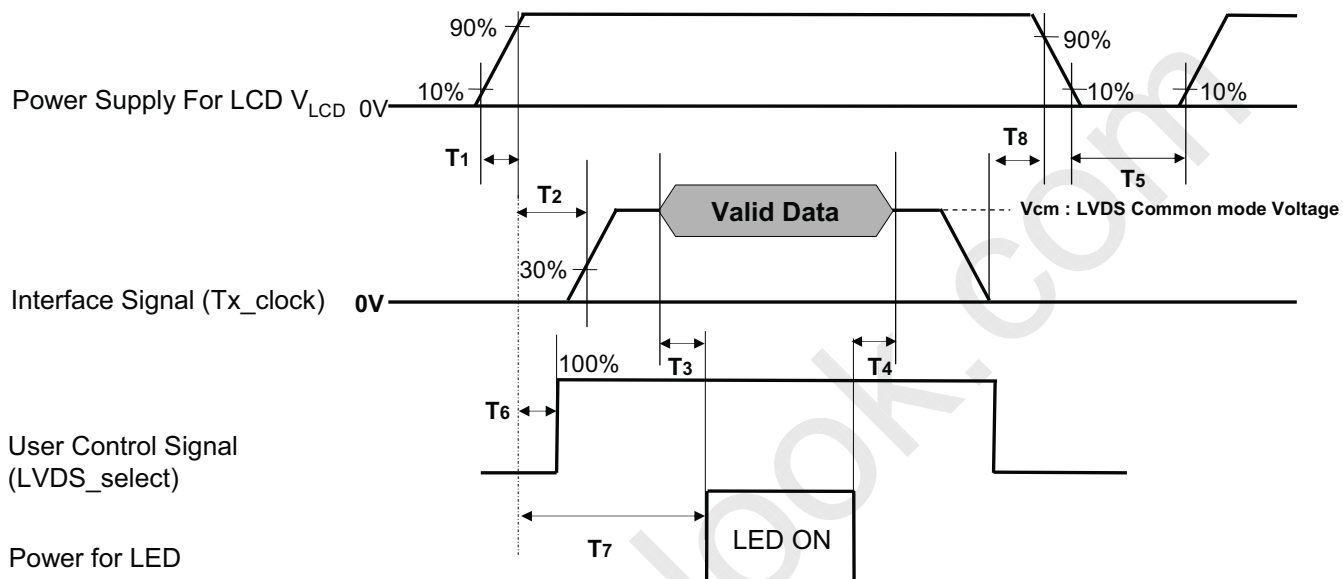

Table 8. POWER SEQUENCE

Parameter	Value			Unit	Notes
	Min	Typ	Max		
T1	0.5	-	20	ms	
T2	0	-	-	ms	4
T3	200	-	-	ms	3
T4	100	-	-	ms	3
T5	1.0	-	-	s	5
T6	-	-	T2	ms	4
T7	0.5	-	-	s	
T8	200	-	-	ms	6

Note :1. Please avoid floating state of interface signal at invalid period.

2. When the power supply for LCD (V_{LCD}) is off, be sure to pull down the valid and invalid data to 0V.

3. The T_3 / T_4 is recommended value, the case when failed to meet a minimum specification, abnormal display would be shown. There is no reliability problem.

4. If the on time of signals (Interface signal and user control signals) precedes the on time of Power (V_{LCD}), it will be happened abnormal display. When T_6 is NC status, T_6 doesn't need to be measured.

5. T_5 should be measured after the Module has been fully discharged between power off and on period.

6. It is recommendation specification that T_8 has to be 100ms as a minimum value.

LC216EXN

Product Specification

3-6-2. Sequence for LED Driver

Power Supply For LED Driver

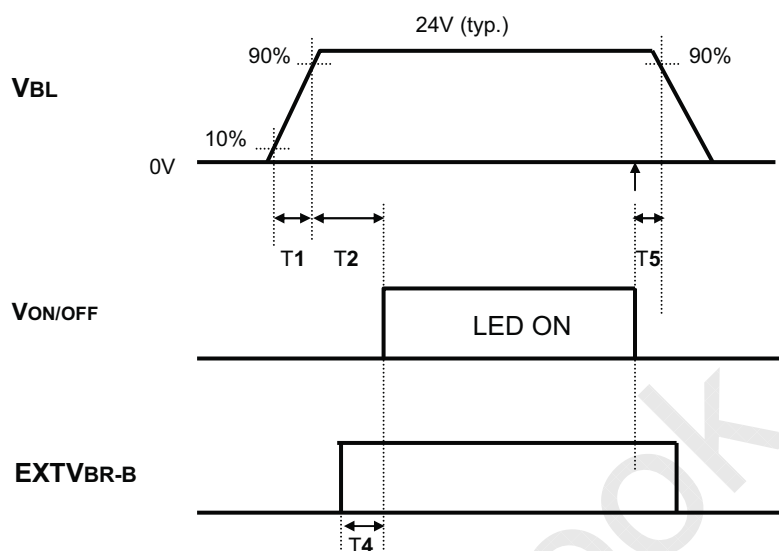

3-6-3. Dip condition for LED Driver

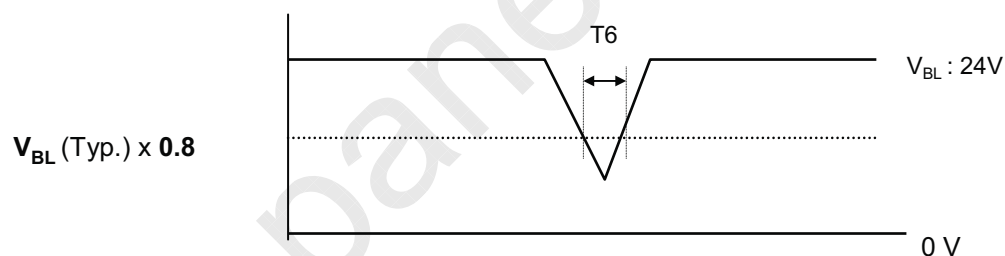

Table 9. Power Sequence for Inverter

Parameter	Values			Units	Remarks
	Min	Typ	Max		
T1	20	-	-	ms	1
T2	500	-	-	ms	
T4	0	-	-	ms	
T5	10	-	-	ms	
T6	-	-	10	ms	$V_{BL}(Typ) \times 0.8$

Notes : 1. T1 describes rising time of 0V to 24V and this parameter does not applied at restarting time.
Even though T1 is over the specified value, there is no problem if I^2T spec of fuse is satisfied.

LC216EXN

Product Specification

4. Optical Specification

Optical characteristics are determined after the unit has been 'ON' and stable in a dark environment at $25\pm 2^\circ\text{C}$. The values are specified at distance 50cm from the LCD surface at a viewing angle of Φ and θ equal to 0° .

FIG. 1 shows additional information concerning the measurement equipment and method.

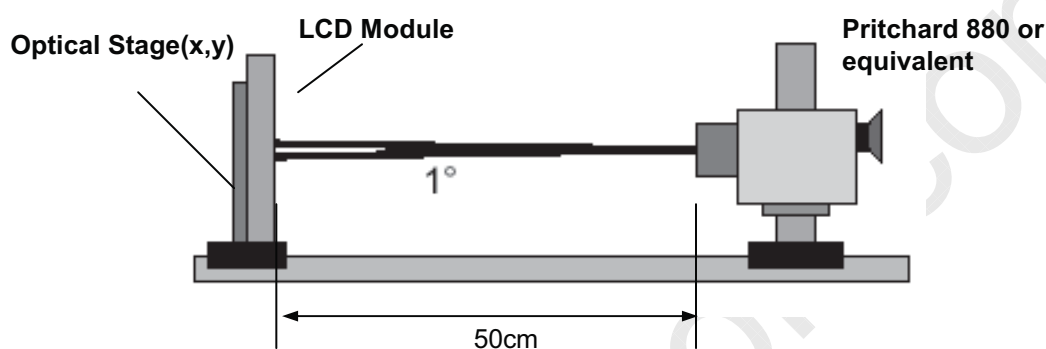

FIG. 1 Optical Characteristic Measurement Equipment and Method

Table 10. OPTICAL CHARACTERISTICS $T_a = 25\pm 2^\circ\text{C}$, $V_{\text{LCD}} = 5.0\text{V}$, $f_v = 60\text{Hz}$, $D_{\text{clk}} = 72.4\text{MHz}$, $\text{EXTVBR-B} = 100\%$

Parameter	Symbol	Value			Unit	Note	
		Min	Typ	Max			
Contrast Ratio	CR	700	1000	-		1	
Surface Luminance, white	L_{WH}	240	300	-	cd/m^2	2	
Luminance Variation	δ_{WHITE} 5P	-	-	1.3		3	
Response Time	Variation G to G σ		6	9	ms	5	
	Gray to Gray (BW)	G to G BW		9	13	ms	4
Color Coordinates [CIE1931]	RED	Rx	Typ -0.03	0.630	Typ +0.03		
		Ry		0.340			
	GREEN	Gx		0.319			
		Gy		0.606			
	BLUE	Bx		0.154			
		By		0.050			
	WHITE	Wx		0.279			
Wy		0.292					
Color Temperature			10,000		K		
Color Gamut			68		%		
Viewing Angle (CR>10)							
	x axis, right($\phi=0^\circ$)	θ_r	89	-	-	degree	6
	x axis, left ($\phi=180^\circ$)	θ_l	89	-	-		
	y axis, up ($\phi=90^\circ$)	θ_u	89	-	-		
	y axis, down ($\phi=270^\circ$)	θ_d	89	-	-		
Gray Scale			-	-	-		7

Product Specification

Notes :1. Contrast Ratio (CR) is defined mathematically as :

$$CR = \frac{\text{Surface Luminance at all white pixels}}{\text{Surface Luminance at all black pixels}}$$

It is measured at center 1-point.

2. Surface luminance is determined after the unit has been 'ON' and 1Hour after lighting the backlight in a dark environment at $25 \pm 2^\circ\text{C}$. Surface luminance is the luminance value at center 1-point across the LCD surface 50cm from the surface with all pixels displaying white. For more information see the FIG. 2.

3. The variation in surface luminance , δ WHITE is defined as :

$$\delta \text{ WHITE}(5P) = \text{Maximum}(L_{on1}, L_{on2}, L_{on3}, L_{on4}, L_{on5}) / \text{Minimum}(L_{on1}, L_{on2}, L_{on3}, L_{on4}, L_{on5})$$

Where L_{on1} to L_{on5} are the luminance with all pixels displaying white at 5 locations .

For more information, see the FIG. 2.

4. Response time is the time required for the display to transit from any gray to white (Rise Time, Tr_R) and from any gray to black (Decay time, Tr_D). For additional information see the FIG. 3.

※ G to G_{BW} Spec stands for average value of all measured points.

Photo Detector : RD-80S / Field : 2°

5. G to G_σ is Variation of Gray to Gray response time composing a picture

$$G \text{ to } G(\sigma) = \sqrt{\frac{\sum(X_i - u)^2}{N}}$$

X_i = Individual Data
 u = Data average
 N : The number of Data

6. Viewing angle is the angle at which the contrast ratio is greater than 10. The angles are determined for the horizontal or x axis and the vertical or y axis with respect to the z axis which is normal to the LCD module surface. For more information, see the FIG. 4.

7. Gray scale specification

Gamma Value is approximately 2.2. For more information, see the Table 11.

Table 11. GRAY SCALE SPECIFICATION

Gray Level	Luminance [%] (Typ.)
L0	0.10
L15	0.27
L31	1.04
L47	2.49
L63	4.68
L79	7.66
L95	11.5
L111	16.1
L127	21.6
L143	28.1
L159	35.4
L175	43.7
L191	53.0
L207	66.7
L223	79.0
L239	90.2
L255	100

LC216EXN

Product Specification

Measuring point for surface luminance & measuring point for luminance variation.

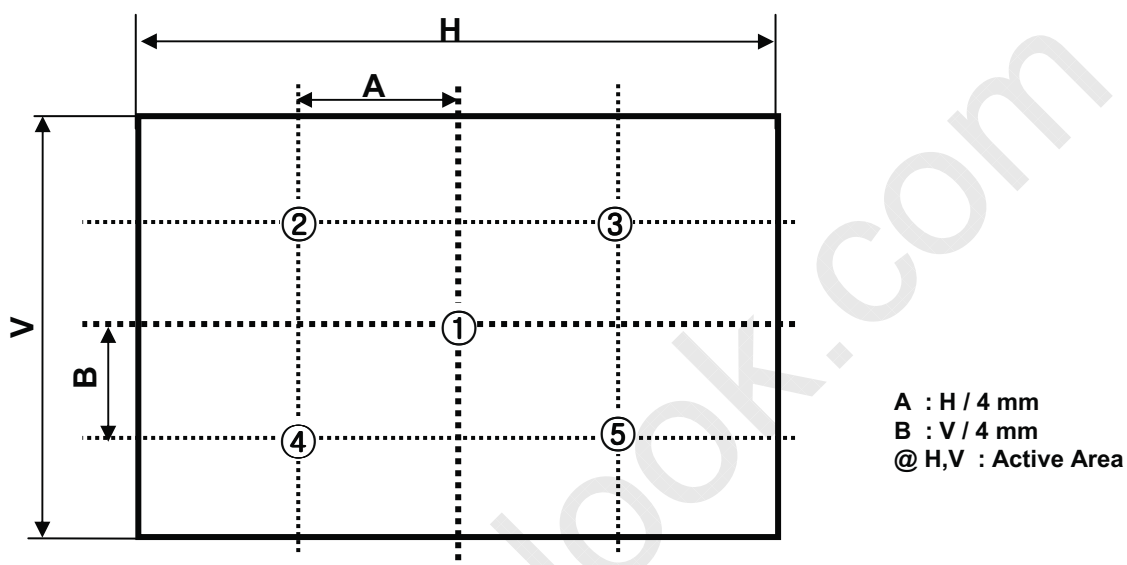

FIG. 2 5 Points for Luminance Measure

Response time is defined as the following figure and shall be measured by switching the input signal for "Gray(N)" and "Black or White".

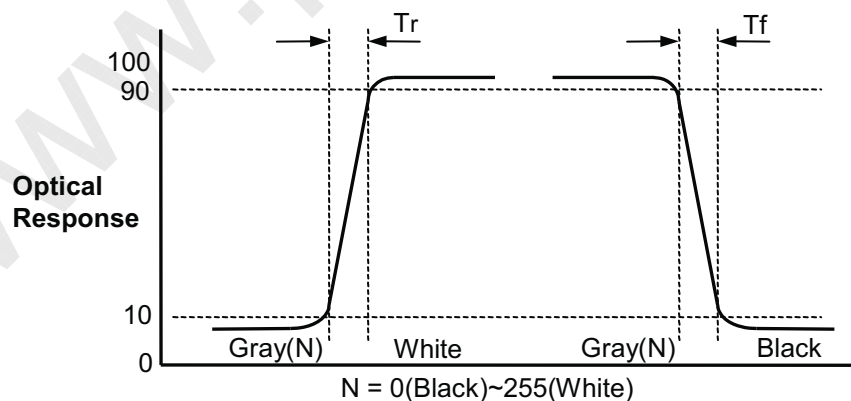

FIG. 3 Response Time

LC216EXN

Product Specification

Dimension of viewing angle range

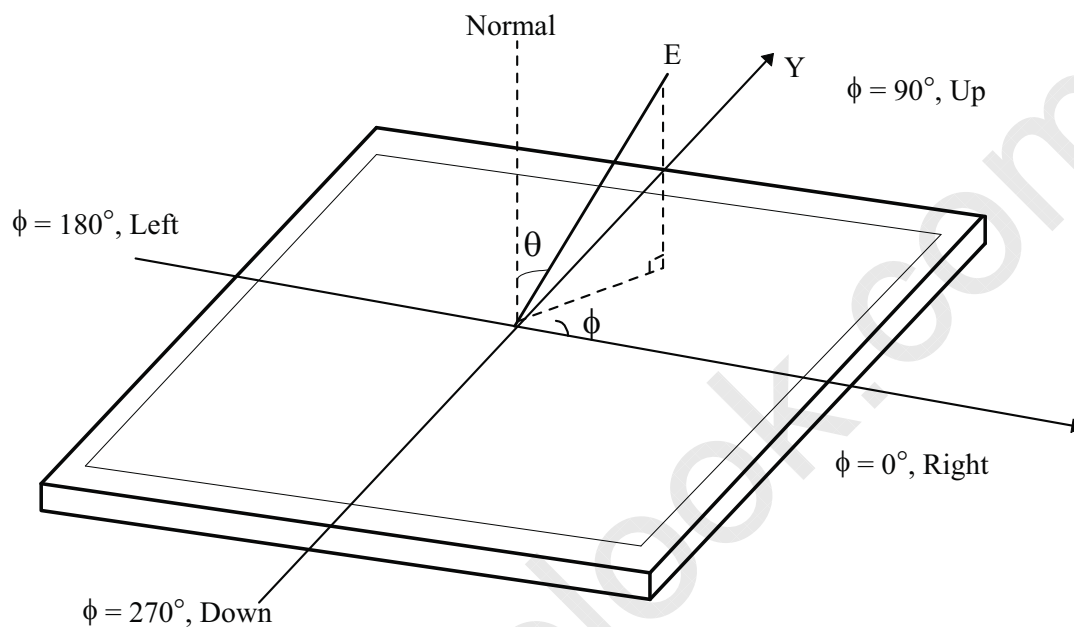

FIG. 4 Viewing Angle

LC216EXN

Product Specification

5. Mechanical Characteristics

Table 12 provides general mechanical characteristics.

Table 12. MECHANICAL CHARACTERISTICS

Item	Value	
Outline Dimension	Horizontal	501.0 mm
	Vertical	297.0 mm
	Depth	12.7 mm
Bezel Area	Horizontal	481.5 mm
	Vertical	272.5 mm
Active Display Area	Horizontal	477.417 mm
	Vertical	268.416 mm
Weight	1,420 g (Typ.), 1,500 g (Max.)	

Note : Please refer to a mechanical drawing in terms of tolerance at the next page.

LC216EXN

Product Specification

<FRONT VIEW>

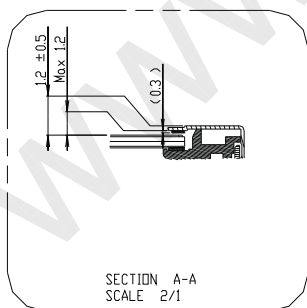
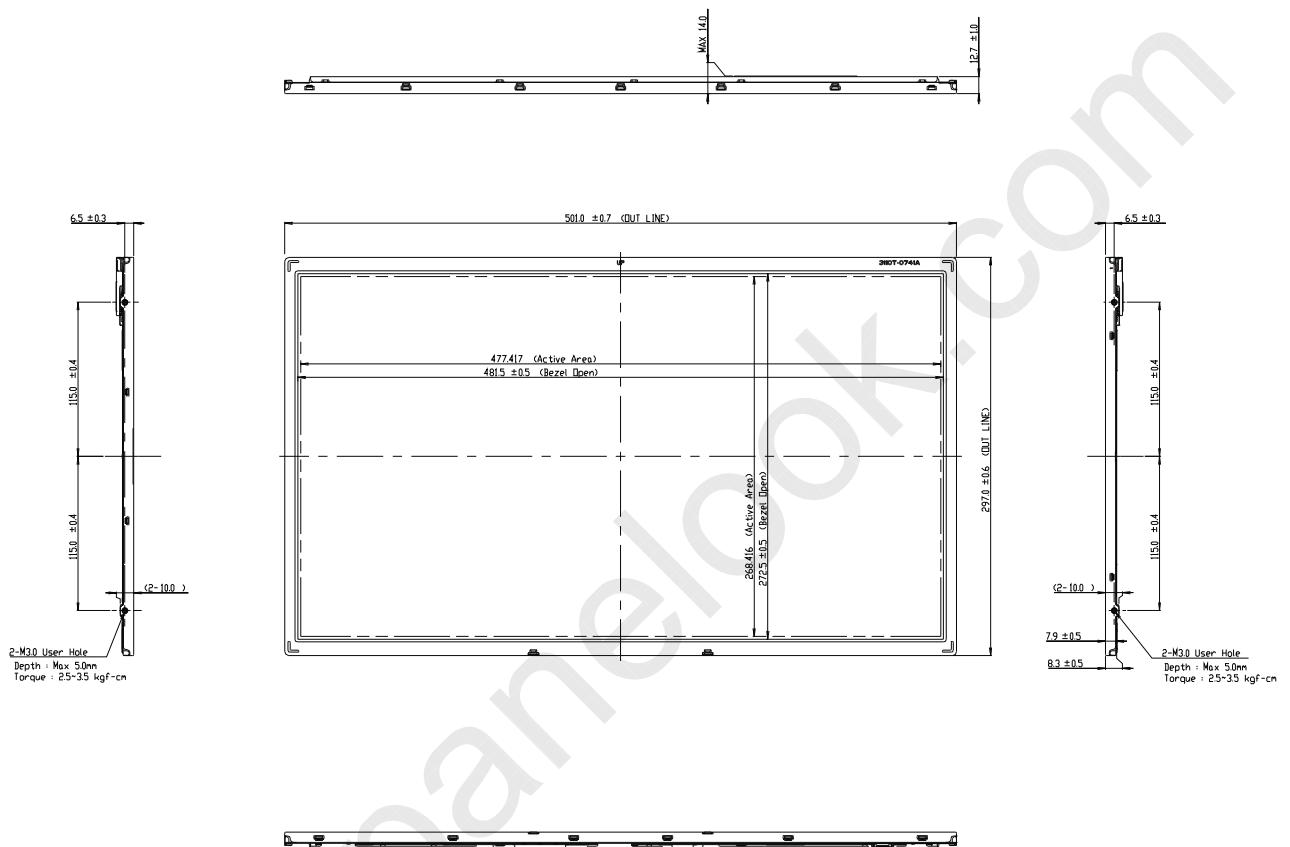

NOTES

1. Unspecified tolerances are to be ± 0.5 mm.
2. Tilt and partial disposition tolerance of display area is as following.
 - (1) X-Direction : IA-BI ≤ 1.0 mm
 - (2) Y-Direction : IC-DI ≤ 1.0 mm

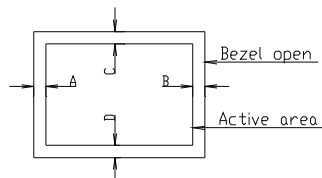

LC216EXN

Product Specification

<REAR VIEW>

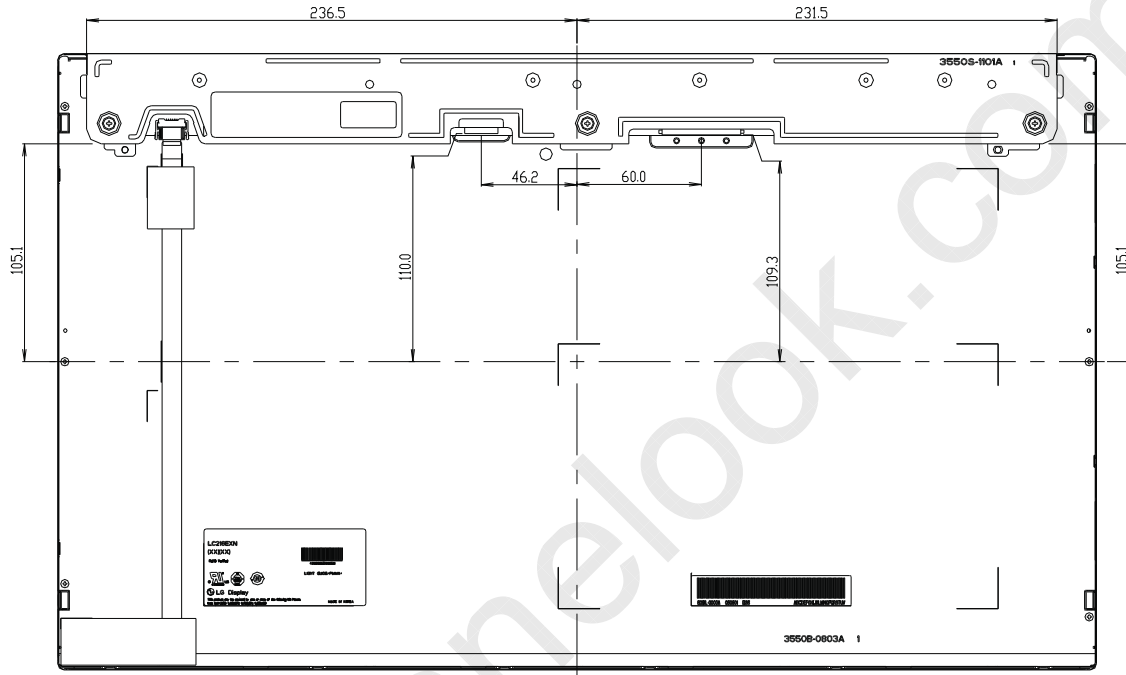

-cm

Ver 1.0

23/37

LC216EXN

Product Specification

6. Reliability**Table 13. ENVIRONMENT TEST CONDITION**

No.	Test Item	Condition
1	High temperature storage test	Ta= 60°C 240h
2	Low temperature storage test	Ta= -20°C 240h
3	High temperature operation test	Ta= 50°C 50%RH 240h
4	Low temperature operation test	Ta= 0°C 240h
5	Vibration test (non-operating)	Wave form : random Vibration level : 1.0Grms Bandwidth : 10-300Hz Duration : X,Y,Z, each direction per 20min
6	Shock test (non-operating)	Shock level : 120G Waveform : half sine wave, 2ms Direction : ±X, ±Y, ±Z each direction
7	Humidity condition Operation	Ta= 40 °C ,90%RH
8	Altitude operating storage / shipment	0 - 15,000 ft 0 - 40,000 ft

Note : Before and after Reliability test, LCM should be operated with normal function.

Product Specification

7. International Standards

7-1. Safety

- a) UL 60065, Seventh Edition, Underwriters Laboratories Inc.
Audio, Video and Similar Electronic Apparatus - Safety Requirements.
- b) CAN/CSA C22.2 No.60065:03, Canadian Standards Association.
Audio, Video and Similar Electronic Apparatus - Safety Requirements.
- c) EN 60065:2002 + A11:2008, European Committee for Electrotechnical Standardization (CENELEC).
Audio, Video and Similar Electronic Apparatus - Safety Requirements.
- d) IEC 60065:2005 + A1:2005, The International Electrotechnical Commission (IEC).
Audio, Video and Similar Electronic Apparatus - Safety Requirements.
(Including report of IEC60825-1:2001 clause 8 and clause 9)

Notes

1. Laser (LED Backlight) Information

Class 1M LED Product IEC60825-1 : 2001 Embedded LED Power (Class 1M)
--

2. Caution

- : LED inside.
- Class 1M laser (LEDs) radiation when open.
- Do not open while operating.

7-2. EMC

- a) ANSI C63.4 "American National Standard for Methods of Measurement of Radio-Noise Emissions from Low-Voltage Electrical and Electronic Equipment in the Range of 9 kHz to 40 GHz." American National Standards Institute (ANSI), 2003.
- b) CISPR 22 "Information technology equipment – Radio disturbance characteristics – Limit and methods of measurement." International Special Committee on Radio Interference (CISPR), 2005.
- c) CISPR 13 "Sound and television broadcast receivers and associated equipment – Radio disturbance characteristics – Limits and method of measurement." International Special Committee on Radio Interference (CISPR), 2006.

7-3. Environment

- a) RoHS, Directive 2002/95/EC of the European Parliament and of the council of 27 January 2003

LC216EXN

Product Specification

8. Packing**8-1. Information of LCM Label**

a) Lot Mark

A	B	C	D	E	F	G	H	I	J	K	L	M
---	---	---	---	---	---	---	---	---	---	---	---	---

A,B,C : SIZE(INCH)
E : MONTH

D : YEAR
F ~ M : SERIAL NO.

Note

1. YEAR

Year	2010	2011	2012	2013	2014	2015	2016	2017	2018	2019
Mark	0	1	2	3	4	5	6	7	8	9

2. MONTH

Month	Jan	Feb	Mar	Apr	May	Jun	Jul	Aug	Sep	Oct	Nov	Dec
Mark	1	2	3	4	5	6	7	8	9	A	B	C

b) Location of Lot Mark

Serial No. is printed on the label. The label is attached to the backside of the LCD module.
This is subject to change without prior notice.

8-2. Packing Form

a) Package quantity in one Box : 12pcs

b) Box Size : 553mm X315 mm X408 mm.

Product Specification

9. Precautions

Please pay attention to the followings when you use this TFT LCD module.

9-1. Mounting Precautions

- (1) You must mount a module using specified mounting holes (Details refer to the drawings).
- (2) You should consider the mounting structure so that uneven force (ex. Twisted stress) is not applied to the module. And the case on which a module is mounted should have sufficient strength so that external force is not transmitted directly to the module.
- (3) Please attach the surface transparent protective plate to the surface in order to protect the polarizer. Transparent protective plate should have sufficient strength in order to resist external force.
- (4) You should adopt radiation structure to satisfy the temperature specification.
- (5) Acetic acid type and chlorine type materials for the cover case are not desirable because the former generates corrosive gas of attacking the polarizer at high temperature and the latter causes circuit break by electro-chemical reaction.
- (6) Do not touch, push or rub the exposed polarizers with glass, tweezers or anything harder than HB pencil lead. And please do not rub with dust clothes with chemical treatment. Do not touch the surface of polarizer for bare hand or greasy cloth. (Some cosmetics are detrimental to the polarizer.)
- (7) When the surface becomes dusty, please wipe gently with absorbent cotton or other soft materials like chamois soaks with petroleum benzene. Normal-hexane is recommended for cleaning the adhesives used to attach front / rear polarizers. Do not use acetone, toluene and alcohol because they cause chemical damage to the polarizer. * There is no problem of Panel crack under 5kgf / ϕ 10mm
- (8) Wipe off saliva or water drops as soon as possible. Their long time contact with polarizer causes deformations and color fading.
- (9) Do not open the case because inside circuits do not have sufficient strength.

9-2. Operating Precautions

- (1) The spike noise causes the mis-operation of circuits. It should be lower than following voltage :
 $V = \pm 200\text{mV}$ (Over and under shoot voltage)
- (2) Response time depends on the temperature. (In lower temperature, it becomes longer.)
- (3) Brightness depends on the temperature. (In lower temperature, it becomes lower.)
And in lower temperature, response time (required time that brightness is stable after turned on) becomes longer.
- (4) Be careful for condensation at sudden temperature change. Condensation makes damage to polarizer or electrical contacted parts. And after fading condensation, smear or spot will occur.
- (5) When fixed patterns are displayed for a long time, remnant image is likely to occur.
- (6) Module has high frequency circuits. Sufficient suppression to the electromagnetic interference shall be done by system manufacturers. Grounding and shielding methods may be important to minimize the interference.
- (7) Please do not give any mechanical and/or acoustical impact to LCM. Otherwise, LCM can't be operated its full characteristics perfectly.
- (8) A screw which is fastened up the steels should be a machine screw.
(if not, it causes metallic foreign material and deal LCM a fatal blow)
- (9) Please do not set LCD on its edge.
- (10) The conductive material and signal cables are kept away from LED driver inductor to prevent abnormal display, sound noise and temperature rising.

Product Specification

9-3. Electrostatic Discharge Control

Since a module is composed of electronic circuits, it is not strong to electrostatic discharge. Make certain that treatment persons are connected to ground through wrist band etc. And don't touch interface pin directly.

9-4. Precautions for Strong Light Exposure

Strong light exposure causes degradation of polarizer and color filter.

9-5. Storage

When storing modules as spares for a long time, the following precautions are necessary.

- (1) Store them in a dark place. Do not expose the module to sunlight or fluorescent light. Keep the temperature between 5°C and 35°C at normal humidity.
- (2) The polarizer surface should not come in contact with any other object.
It is recommended that they be stored in the container in which they were shipped.
- (3) Storage condition is guaranteed under packing conditions.
- (4) The phase transition of Liquid Crystal in the condition of the low or high storage temperature will be recovered when the LCD module returns to the normal condition

9-6. Handling Precautions for Protection Film

- (1) The protection film is attached to the bezel with a small masking tape.
When the protection film is peeled off, static electricity is generated between the film and polarizer.
This should be peeled off slowly and carefully by people who are electrically grounded and with well ion-blown equipment or in such a condition, etc.
- (2) When the module with protection film attached is stored for a long time, sometimes there remains a very small amount of glue still on the bezel after the protection film is peeled off.
- (3) You can remove the glue easily. When the glue remains on the bezel surface or its vestige is recognized, please wipe them off with absorbent cotton waste or other soft material like chamois soaked with normal-hexane.

LC216EXN

Product Specification

APPENDIX- I-1

■ Packing Ass'y

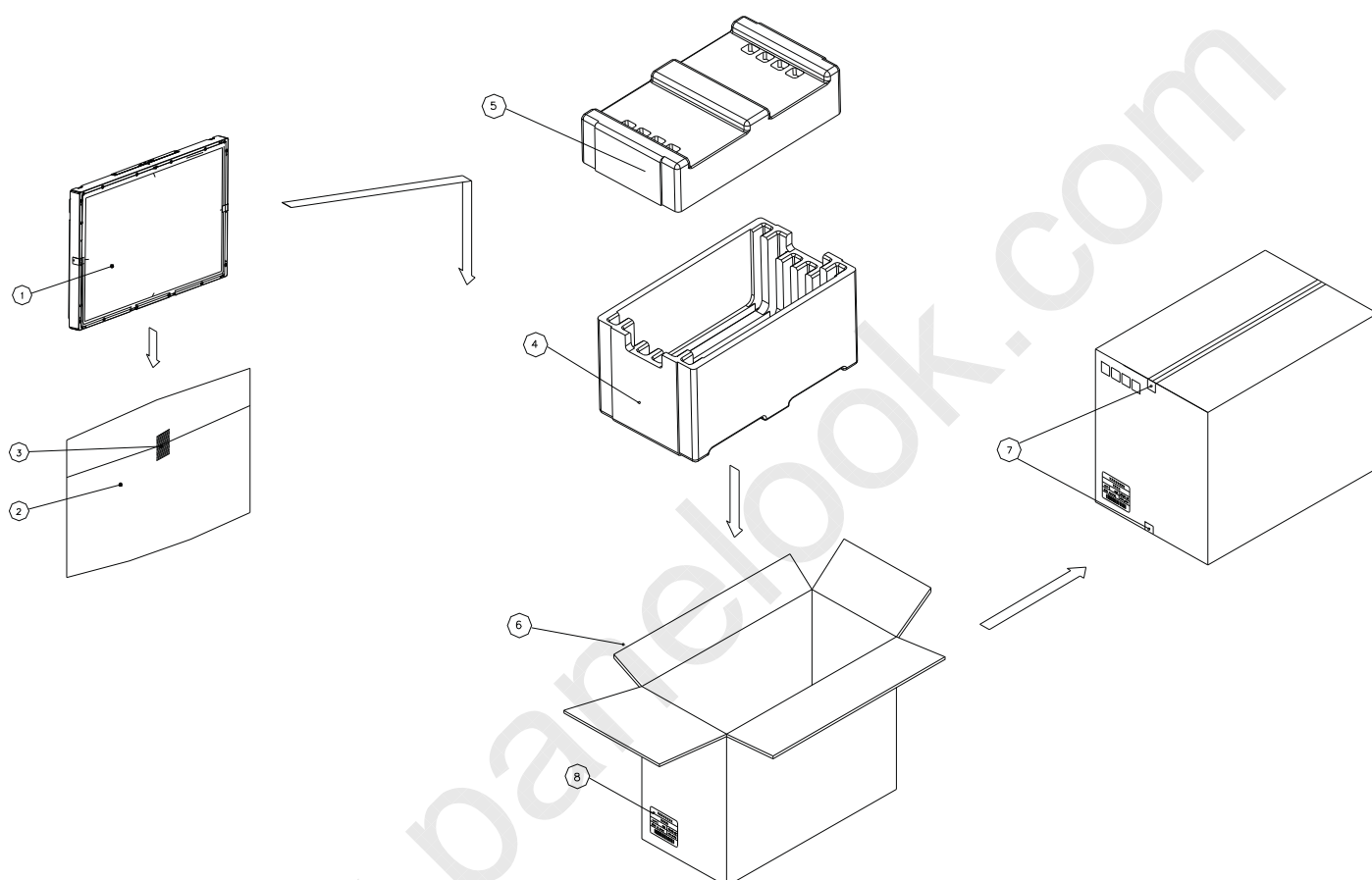

NO.	DESCRIPTION	MATERIAL
1	LCM	
2	BAG	AL
3	TAPE	OPP
4	PACKING, BOTTOM	EPS
5	PACKING, TOP	EPS
6	BOX	PAPER, SW
7	TAPE	OPP
8	LABEL	ART

LC216EXN

Product Specification

APPENDIX- I-2

■ Pallet Ass'y

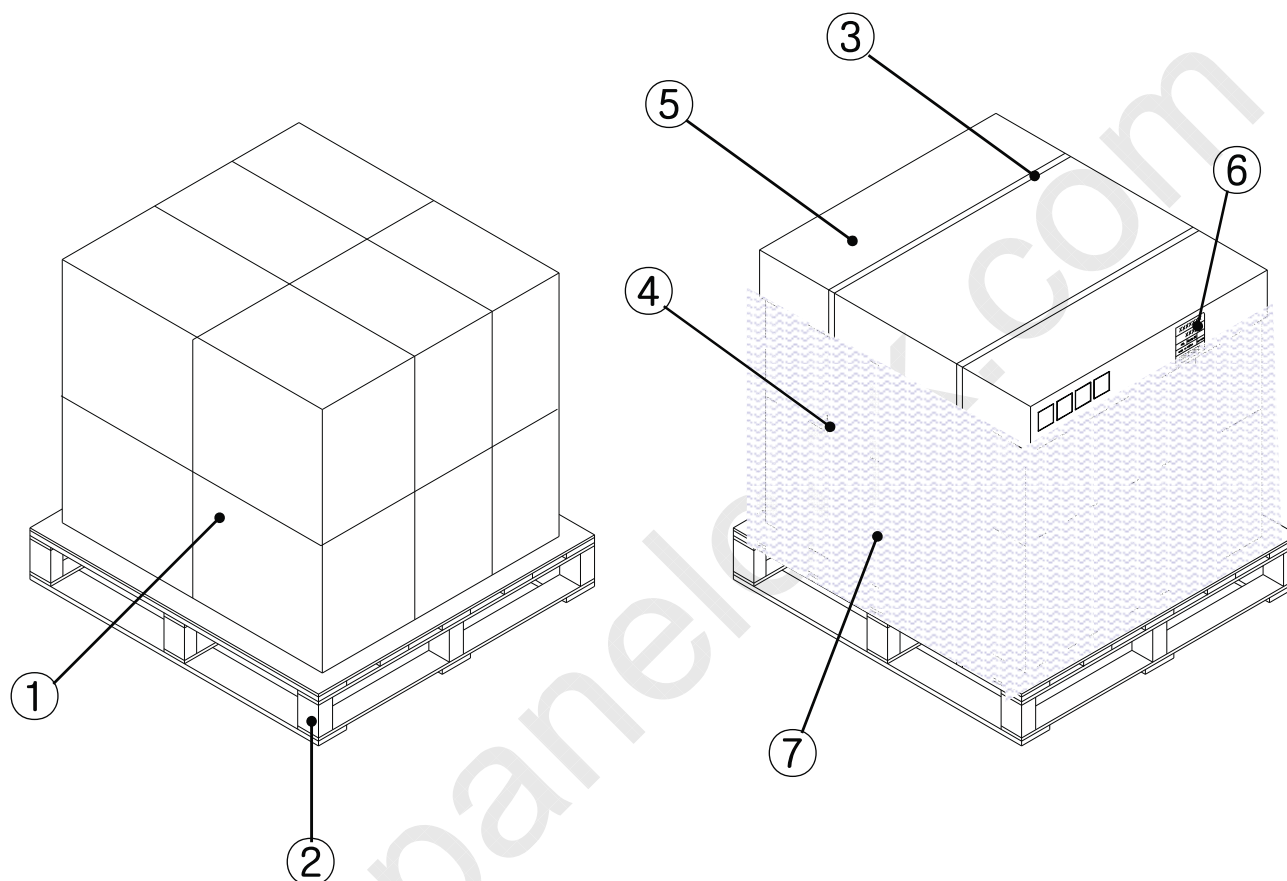

NO.	DESCRIPTION	MATERIAL
1	PACKING ASS'Y	-
2	PALLET	PLYWOOD_1140X990X117.5
3	BAND	PP
4	BAND, CLIP	CLIP
5	ANGLE COVER	PAPER, SW
6	LABEL	ART
7	WRAP	LLDPE

LC216EXN

APPENDIX- II-1

■ LCM Label



LC216EXN

APPENDIX- II-2

■ Box Label

LC216EXN		
SDA2		
12 pcs	001/01-01	
MADE IN KOREA		RoHS Verified
		

■ Pallet Label

LC216EXN		
SDA2		
144 pcs	001/01-01	
MADE IN KOREA		RoHS Verified
		

LC216EXN

Product Specification

APPENDIX- III-1

■ Required signal assignment for Flat Link Transmitter (Pin 21 = "H or NC")

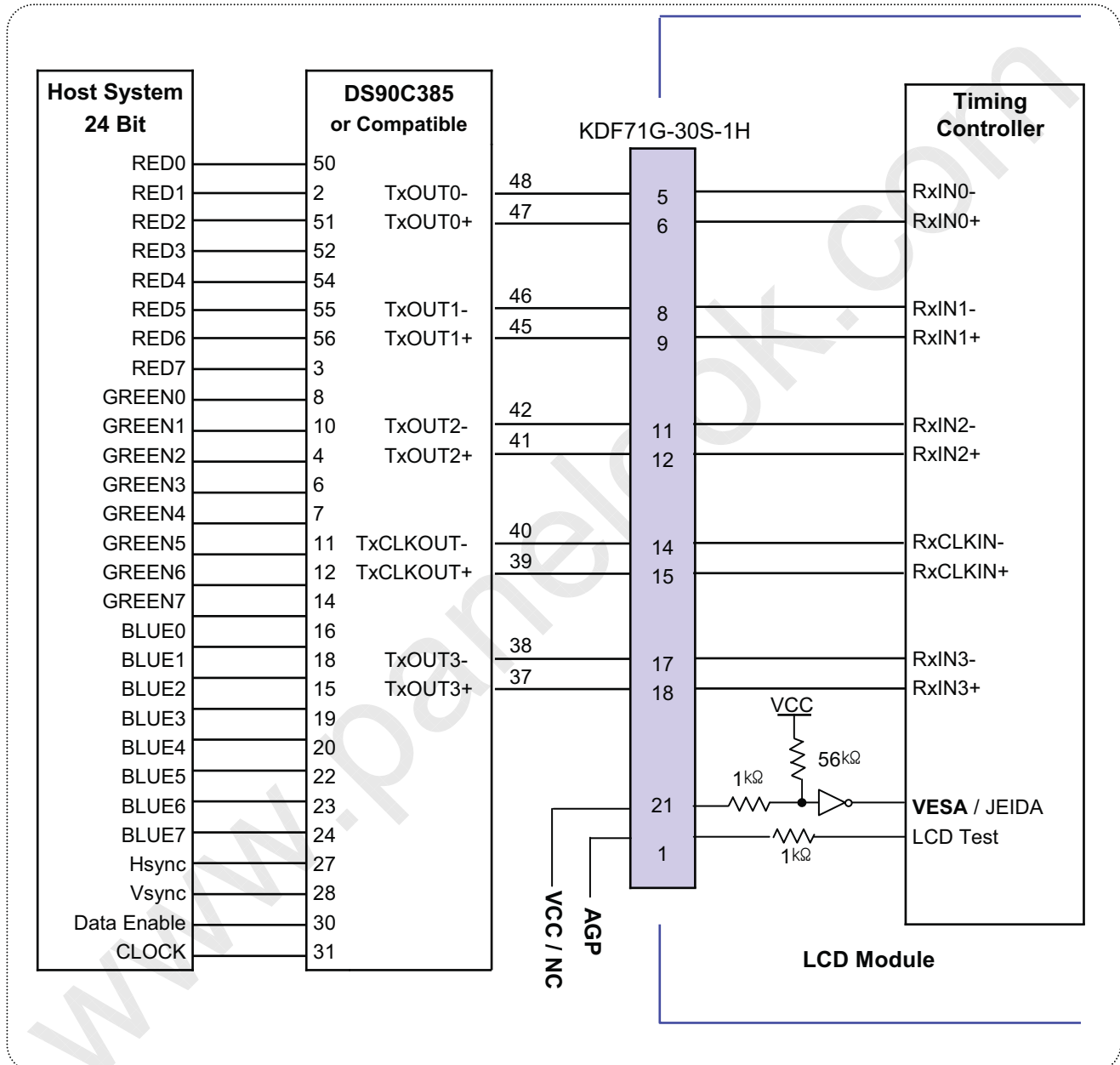

Notes:

1. The LCD module uses a 100 ohm(Ω) resistor between positive and negative lines of T-con Internal.
2. Refer to LVDS transmitter data sheet for detail descriptions. (DS90C385 or Compatible)
3. '7' means MSB and '0' means LSB at R,G,B pixel data.

LC216EXN

Product Specification

APPENDIX- III-2

■ Required signal assignment for Flat Link Transmitter (Pin 21 ="L")

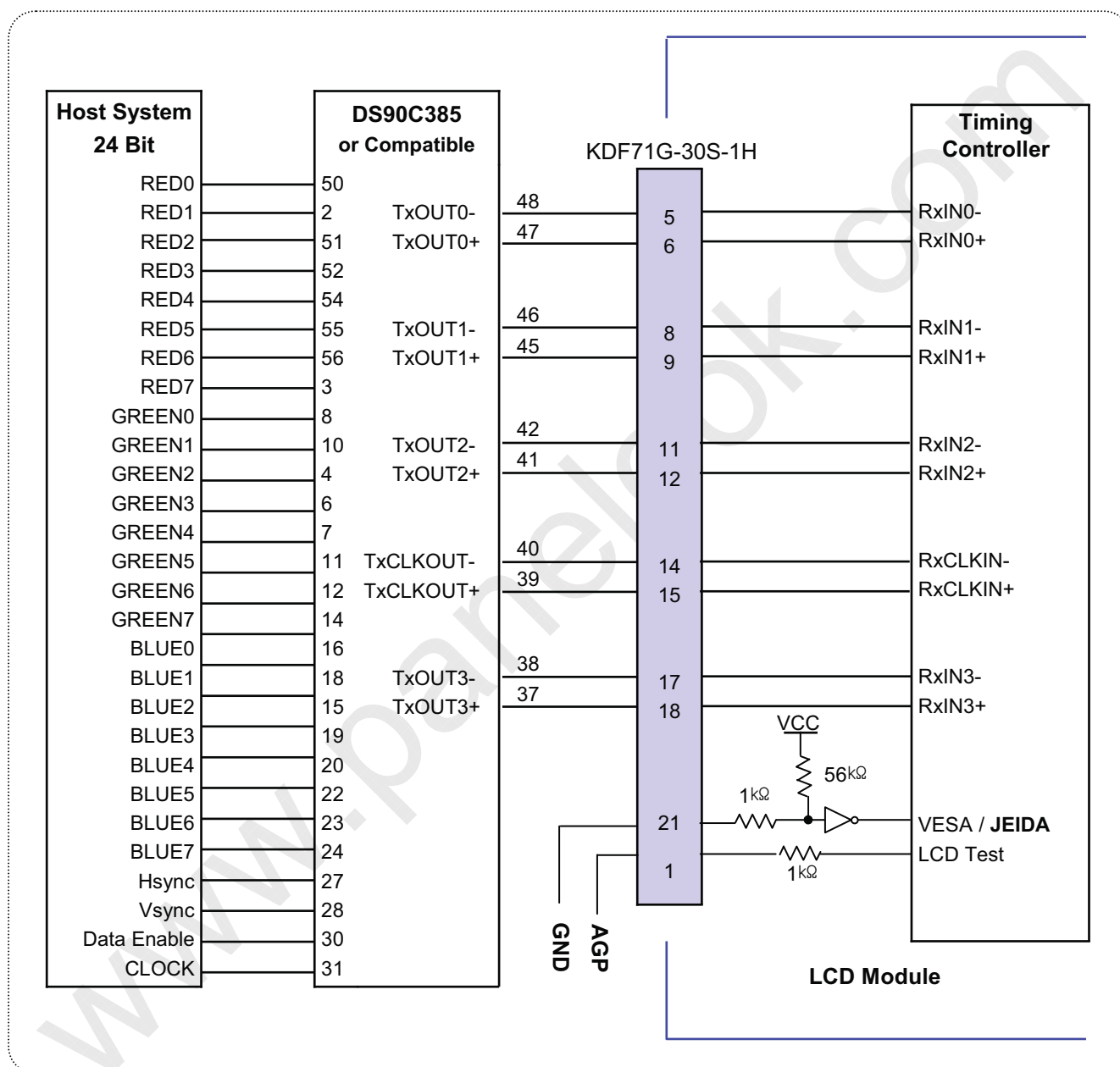

Notes:

1. The LCD module uses a 100 ohm(Ω) resistor between positive and negative lines of T-con Internal.
2. Refer to LVDS transmitter data sheet for detail descriptions. (DS90C385 or Compatible)
3. '7' means MSB and '0' means LSB at R,G,B pixel data.

APPENDIX- IV

LVDS Data-Mapping info. (8bit)

■ LVDS Select : "L" Data-Mapping (JEIDA format)

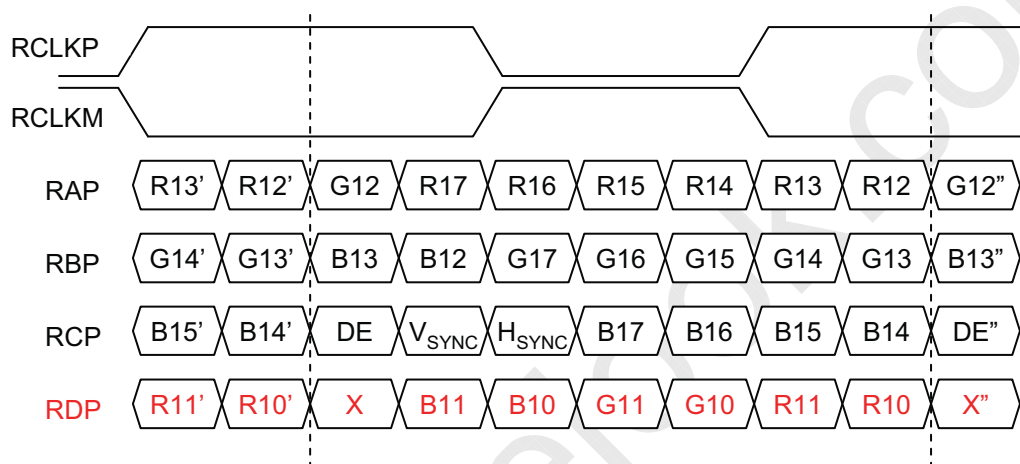

■ LVDS Select : "H or NC" Data-Mapping (VESA format)

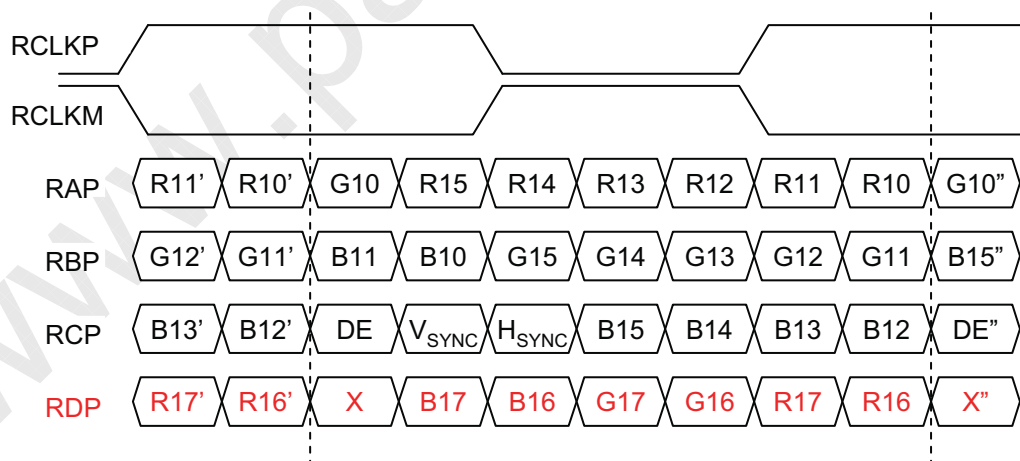

APPENDIX- V

Option Pin Circuit Block Diagram

Circuit Block Diagram of LVDS Format Selection pin

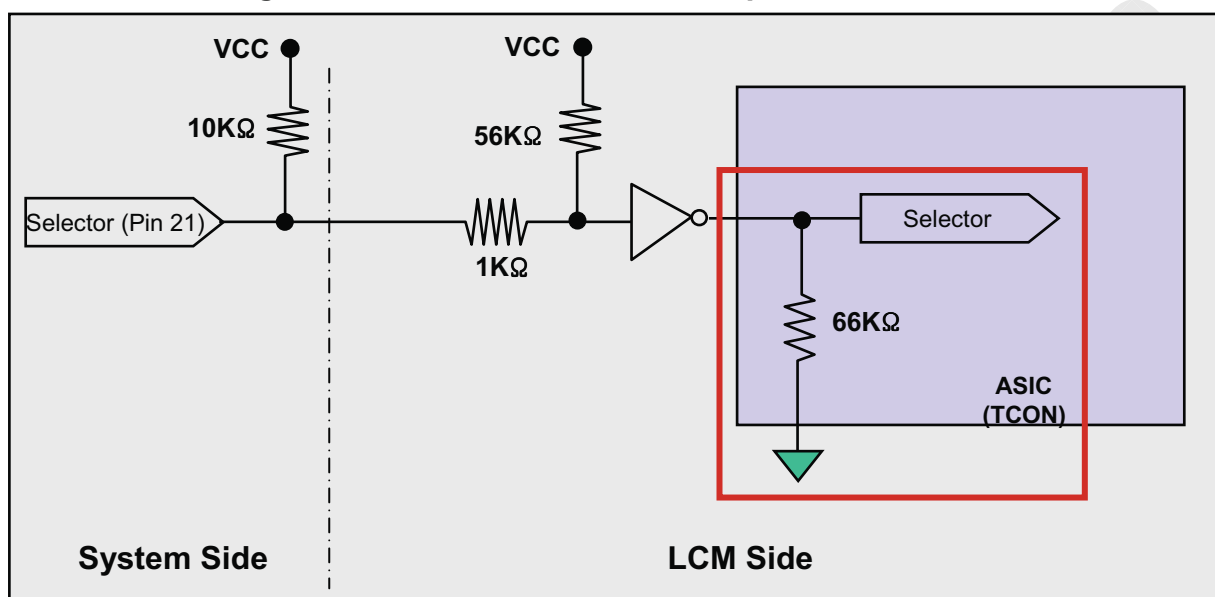

LC216EXN

Product Specification

APPENDIX- VI

■ Drop Test [Packing Condition]

Direction	Transportation
Drop Height	30cm
Number of Drop	2

- Note : 1. Before and after test, LCM should be operated with normal function.
2. Product reliability of Drop had been verified, so there are not any test in LG Display.

